

1. CONTRACTORS MUST CHECK ALL DIMENSIONS ON SITE. ONLY FIGURED DIMENSIONS ARE TO BE WORKED FROM. DISCREPANCIES MUST BE REPORTED TO THE ARCHITECT OR ENGINEER BEFORE PROCEEDING. © THIS DRAWING IS COPYRIGHT.
2. REPRODUCED FROM OS SITEMAP © BY PERMISSION OF ORDNANCE SURVEY® ON BEHALF OF THE CONTROLLER OF HER MAJESTY'S STATIONERY OFFICE. © CROWN COPYRIGHT 2008. ALL RIGHTS RESERVED. LICENCE NUMBER 100007126.
3. UNTIL TECHNICAL APPROVAL HAS BEEN OBTAINED FROM THE RELEVANT AUTHORITIES, ALL DRAWINGS ARE ISSUED AS PRELIMINARY AND NOT FOR CONSTRUCTION. SHOULD THE CONTRACTOR COMMENCE SITE WORK PRIOR TO APPROVAL BEING GIVEN IT IS ENTIRELY AT HIS OWN RISK.

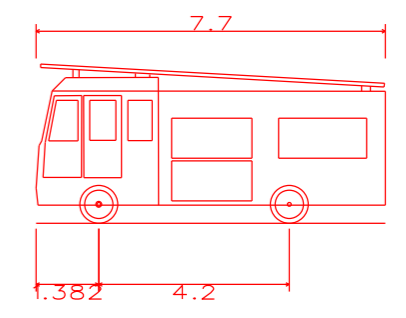

Dennis Sabre Fire Tender (LWB)
 Overall Length 7.700m
 Overall Width 2.430m
 Overall Body Height 3.512m
 Min Body Ground Clearance 0.397m
 Track Width 2.380m
 Lock to Lock Time 5.00s
 Kerb to Kerb Turning Radius 7.400m

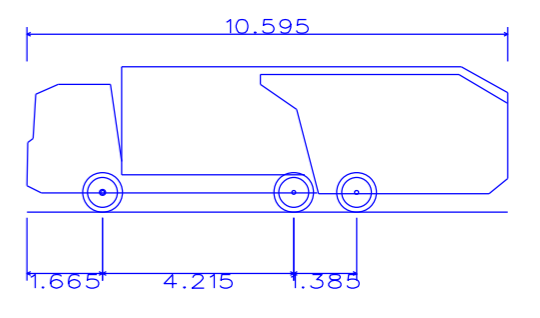

Phoenix 2-23W (with Elite 2 6x4 chassis)
 Overall Length 10.595m
 Overall Width 2.530m
 Overall Body Height 3.205m
 Min Body Ground Clearance 0.410m
 Track Width 2.500m
 Lock to Lock Time 4.00s
 Kerb to Kerb Turning Radius 9.250m

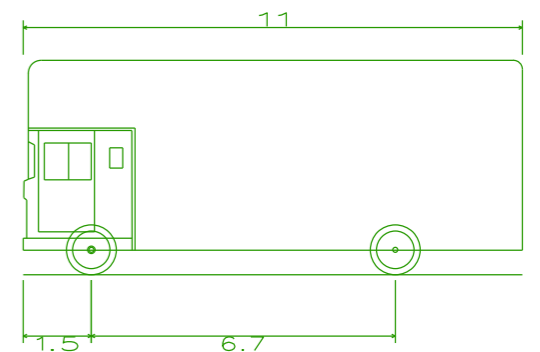

Pantechnicron
 Overall Length 11.000m
 Overall Width 2.500m
 Overall Body Height 4.730m
 Min Body Ground Clearance 0.541m
 Track Width 2.500m
 Lock to Lock Time 6.00s
 Kerb to Kerb Turning Radius 12.200m

REVISION	DESCRIPTION	AT	JF	22.01.19
A	UPDATED TO SUIT LATEST LAYOUT			

PRELIMINARY INFORMATION TENDER CONSTRUCTION AS BUILT

WOODS HARDWICK
 ARCHITECTS, ENGINEERS AND DEVELOPMENT CONSULTANTS

TITLE **UPPER HEYFORD**
 DETAILS **TRENCHARD CIRCLE TRACKING**
 SCALE: 1:250 @ A1 DATE: AUGUST 2016 DRAWN: AT CHK: JF