

NOTES

- The contractor is responsible for checking dimensions, tolerances and references. Any discrepancy to be verified with the Architect before proceeding with the works.
- Where an item is covered by drawings to different scales the larger scale drawing is to be worked to.
- Do not scale drawing. Figured dimensions to be worked to in all cases.

The structural / civil engineering and other non-architectural information shown on this drawing is purely for co-ordination purposes only and in no way does it take on any responsibility or liability for MBA Ltd. For all detailed information relating to these items see the relevant consultants drawings and full design information.

Do not copy in full or in part without the expressed consent of MBA Ltd.

© MBA 2019  
CDM Regulations 2015

ALL current drawings and specifications for the project must be read in conjunction with the Designer's Hazard and Environmental Assessment Record.

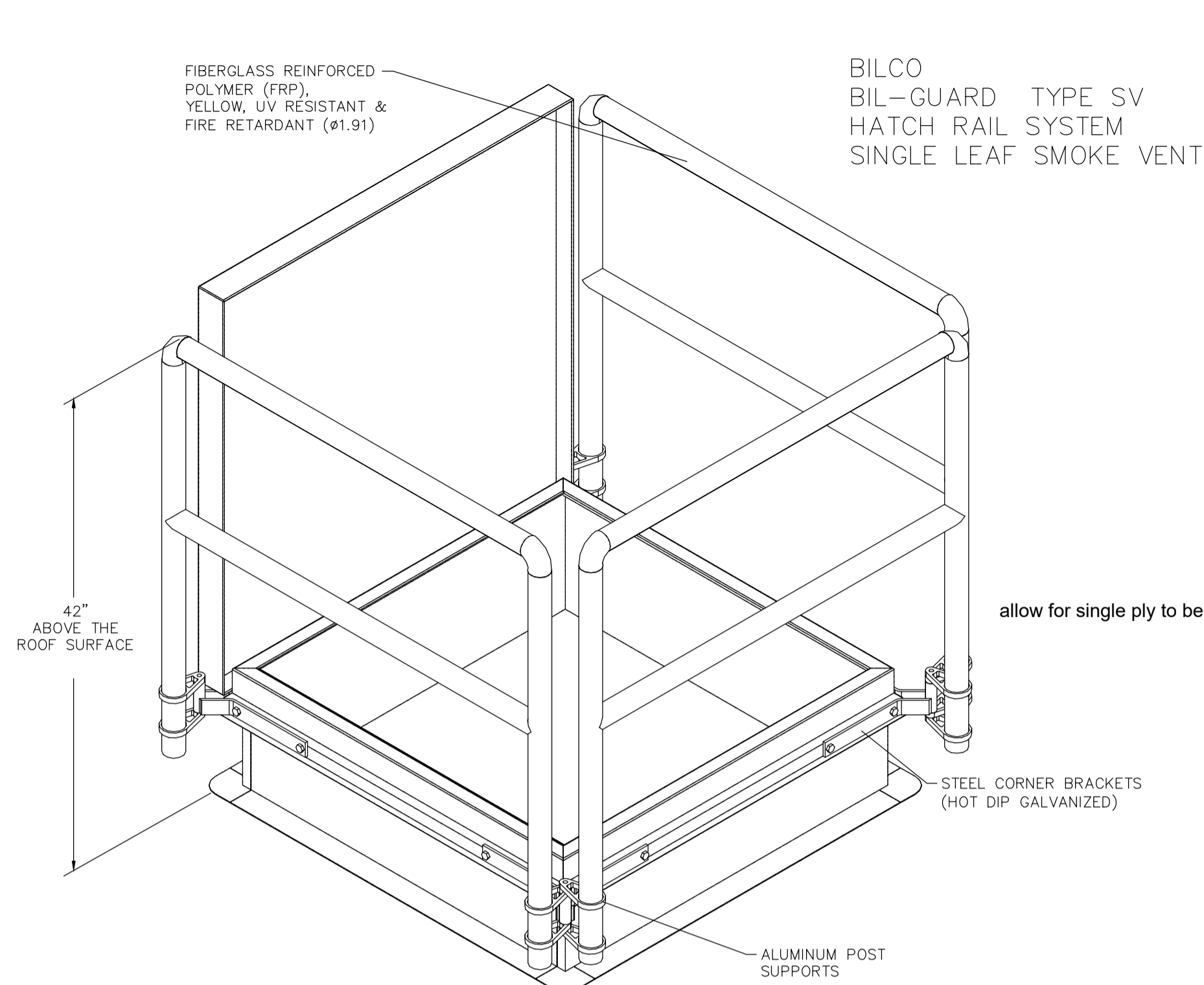

allow for single ply to be fully dressed around base and additional protection membrane pavers allowed

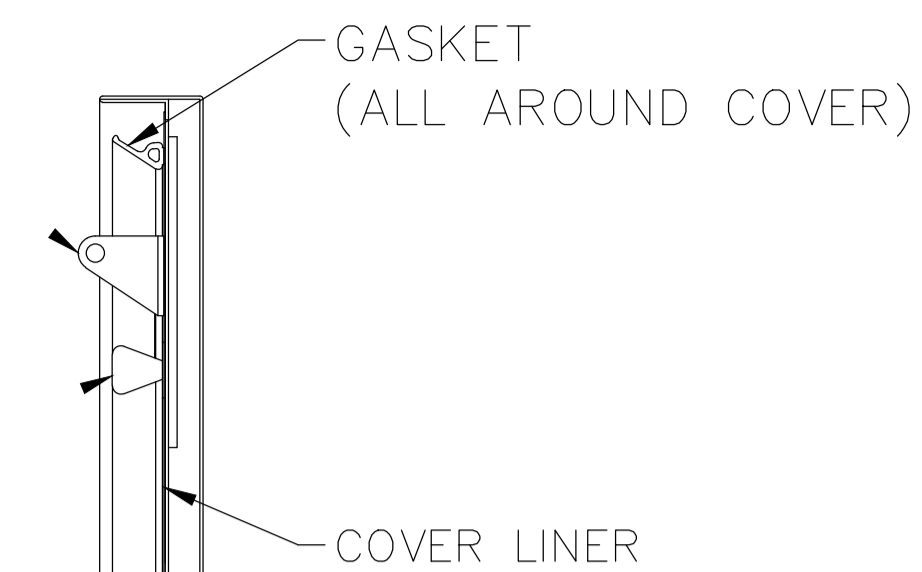

01 SUPERSTRUCTURE DETAILS  
CROWN ROOF TYPICAL ROOF PROTECTION

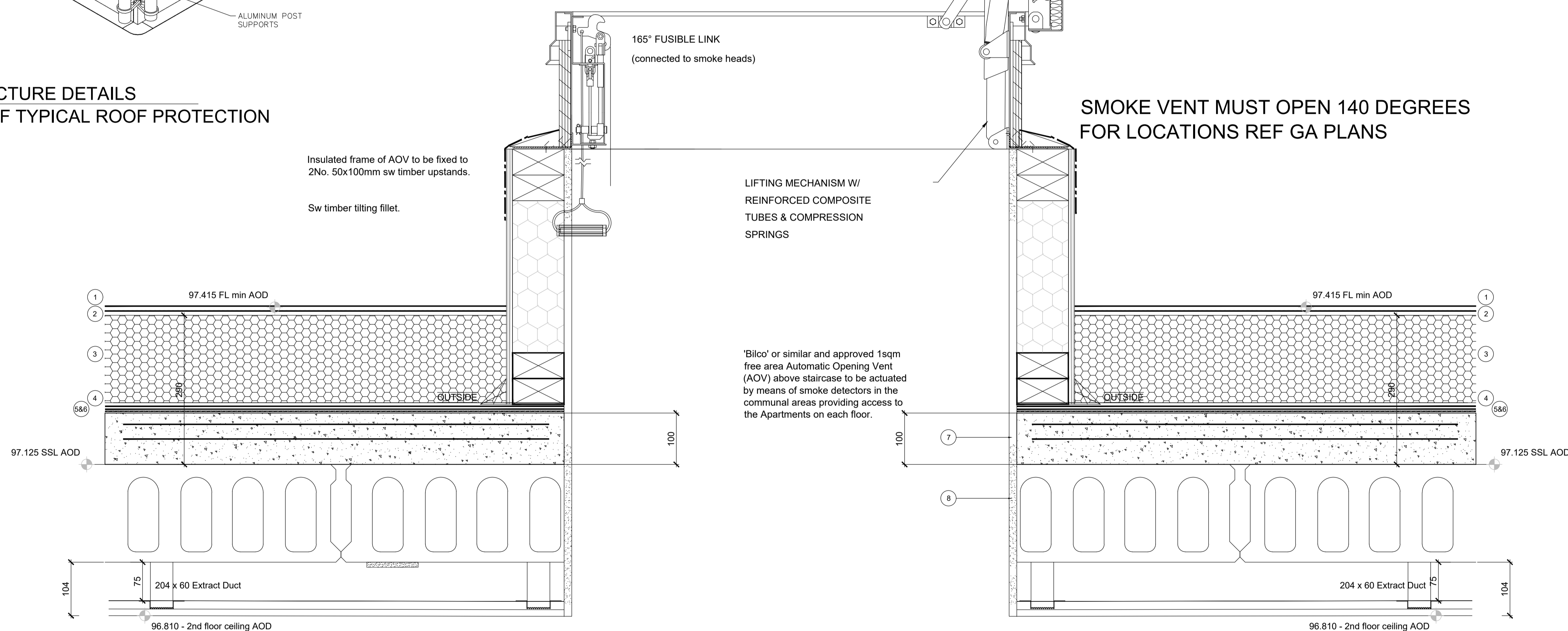

01 SUPERSTRUCTURE DETAILS  
ROOF BUILDUP THRO SMOKE VENT TO STAIR & SEPARATE ROOF ACCESS

REV:	DESCRIPTION:	BY:	DATE:
------	--------------	-----	-------

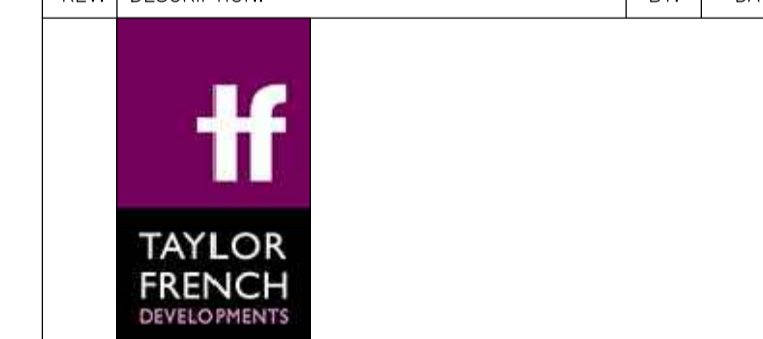

STATUS: Contractor/Tender set



CLIENT: Taylor French  
Taylor French Barns  
Shipston  
Winslow - MK18 3JL

ARCHITECT: Mark Bell Architects Ltd  
The Braid, Little Street  
Sulgrave, Oxfordshire OX17 2SG  
Tel 07788251765 W-markbellarchitects.com

SITE: ELMSBROOK NEIGHBOURHOOD CENTRE, NW BICESTER

TITLE: SUPERSTRUCTURE DETAILS - sheet 26

SCALE AT A1:	DATE:	DRAWN:	CHECKED:
1:5/1:10	08/04/20	MDB	MB
PROJECT NO:	DRAWING NO:	REVISION:	
AA048	AA048/6.1/026	C1	