



Heritage Assessment of The North Arms, Mills Ln, Wroxton, Banbury OX15 6PY



MARCH 2019 Rock Davidson Associates Historic Building Consultants

Contents

1.1	The Consultants	3
1.2	The Client	3
1.3	Background Heritage Statements and Assessments of Significance	3
1.4	Methodology.....	4
1.5	Limitations.....	4
1.6	Copyright.....	4
1.7	Acknowledgements.....	4
2.	The Site & Constraints.....	5
2.1	Location.....	5
2.2	Planning Search.....	6
2.2.1	The North Arms was registered as an Asset of Community value on 20 th October 2016 ACV037. 8	8
2.3	Background to Listed Building Consent and the NPPF.....	8
2.4	The Sites Listed Building Descriptions.....	10
2.5	Other Listed Buildings	13
2.6	Conservation Area.....	15
3	Setting and Vistas.....	16
3.1	Historical Background -Wroxton.....	16
3.1.2	Historical Area Assessment-Location and Landscape Setting.....	17
3.2	Current Setting Photographic Views.....	19
4	Assessment of the North Arms Mills Lane Wroxton.....	20
4.1	Scope of Assessment.....	20
4.2	Map Regression.....	20
4.3	Historical research	21
4.4	Historical Photographs & Analysis	23
4.5	Phasing of Main Buildings & Stable	25
5.	Current Photographic Record and Descriptions Building Recording Level 1-2 The North Arms with Significance Levels	26
5.1	Exterior Main Buildings.....	27
5.2	Interior: Main Building and note of significant features.....	36
5.2.1	GROUND FLOOR: CELLAR.....	36
5.2.2	GROUND FLOOR.....	37

Heritage Assessment of The North Arms, Mills Ln, Wroxton, Banbury OX15 6PY

5.2.3 FIRST FLOOR.....	42
5.2.4 SECOND FLOOR.....	48
5.3 Exterior Stable Building.....	54
5.4 Interior: note of significant features Stable Building.....	56
6 Summary Assessment of Significance North Arms and Stable	58
6.1 Background to Assessments of Significance	58
6.1.2 Evidential Value/Architectural Value	59
6.1.3 Historical Value-	60
6.1.4 Aesthetic /Setting/Group Value.....	60
6.1.5 Community Value.....	60
6.2 Statement of Significance	60
Bibliography	61
Appendix Surveyors Plans.....	63

1.1 The Consultants

Rock- Davidson Associates.

Consultants: **Louisa Davidson** MA [Dist] HistEnvCons BA(Hons) **IHBC** and **Jacob Rock** MA PGDip[Dist] HistEnvCons PGCE

1.2 The Client

Wroxton College C/o Brear Associates Ltd The Beer House, Atherstone Hill, Atherstone on Stour

Stratford upon Avon Warwickshire CV37 8NF

1.3 Background Heritage Statements and Assessments of Significance

Heritage statements/assessments should ideally be prepared by an appropriate professional with the necessary expertise to properly assess the heritage asset and its significance. For buildings or sites of high significance [e.g. for nationally designated heritage assets/listed buildings] it is recommended that the statement be prepared by an architectural historian, an accredited conservation architect or qualified archaeologist. It is required under legislation National Planning Policy Framework 2018 [NPPF] in England that an understanding of the history and fabric a building, and what makes it special architecturally, historically, its exterior elevations and it's setting, this includes the interiors, including historic fixtures and fittings, is necessary when making changes. NPPF 2018 policy paragraph 189 states "assets assessed using appropriate expertise"

Proposals affecting heritage assets

189. In determining applications, local planning authorities should require an applicant to describe the significance of any heritage assets affected, including any contribution made by their setting. The level of detail should be proportionate to the assets' importance and no more than is sufficient to understand the potential impact of the proposal on their significance. As a minimum the relevant historic environment record should have been consulted and the heritage assets assessed using appropriate expertise where necessary. Where a site on which development is proposed includes, or has the potential to include, heritage assets with archaeological interest, local planning authorities should require developers to submit an appropriate desk-based assessment and, where necessary, a field evaluation.

The British Standards BS 7913 guide to 'The Conservation Of Historic Buildings' recommends "using competent qualified experts in the field of conservation when assessing significance" IHBC credentials and post-nominal letters are recognised as appropriate validation. This report will enable the LPA to fully understand how the proposed changes will impact on the significance of this listed building.

1.4 Methodology

This is a desk and web based assessment using books, and appropriate websites. Oxfordshire Archaeology Dr Jacqueline Pitt HER Officer Archaeology County Hall New Road Oxford OX1 1ND was consulted and confirmed that there had been no recent amendments to the entry of the property The North Arms Wroxton and the information is the same as that on Historic England List Description. This assessment has been commissioned to help inform the LPA on a proposal but is not an analysis of any proposed new works or the impact. A Schedule of works and Impact Assessment should be carried out taking into account the findings from this heritage report. This Report does include an some assessment of significance of the heritage asset and its surroundings and analysis of the historic fabric as found and could be seen on February 15th 2019

There was one site visits made on February 15th 2019 to access and take photographs, equivalent to a Level 1-2 Building Recording, [Ref *Understanding Historic Buildings A Guide to Good Recording Practice Historic England May 2016*]

1.5 Limitations

Not able to gain access to Cold Store roof void. Limited access to main house roof. No lifting of floor coverings was undertaken.

1.6 Copyright

Rock Davidson Associates shall retain full copyright of any commissioned reports, tender documents or other project documents, under the Copyright, Designs and Patents Act 1988 with all rights reserved; excepting that it hereby provides a licence to the client and the Council for the use of the report by the client and the Council in all matters directly relating to any planning matters and to use the documentation for their statutory functions and to provide copies of it to third parties as an incidental to such functions. This document has been prepared for the stated purpose in accordance with the Agreement under which our services were commissioned and should not be used for any other purpose without the prior written consent of RDA. No Liability to third parties is accepted for advice and statements made in this report. The facts contained within are written to the best of our knowledge with resources available

All photographs by RDA unless otherwise stated.

1.7 Acknowledgements

Wroxton College Librarian, NW Alcock ,Maureen Woollacott

2. The Site & Constraints



Photo of Building North Arms for this Assessment

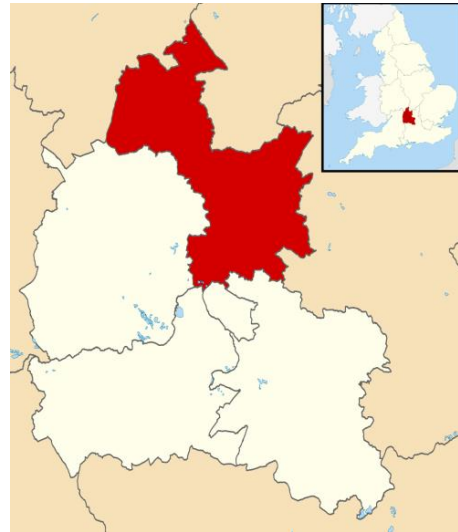

Cherwell District Council North Oxfordshire

2.1 Location

Name: The North Arms, Mills Lane, Wroxton, Banbury OX15 6PY

Designation: Grade II Listed with Grade II Listed Stable

Owner : Wroxton College Fairleigh Dickinson University Wroxton, Banbury OX15 6PX

LPA : Cherwell District Council North Oxfordshire

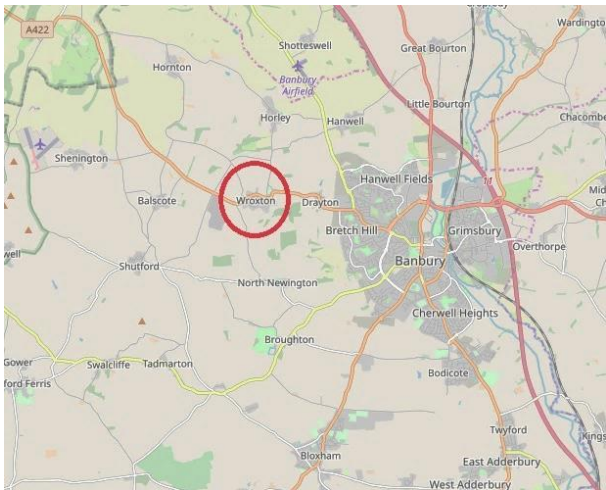

Map Location © OpenStreetMap contributors

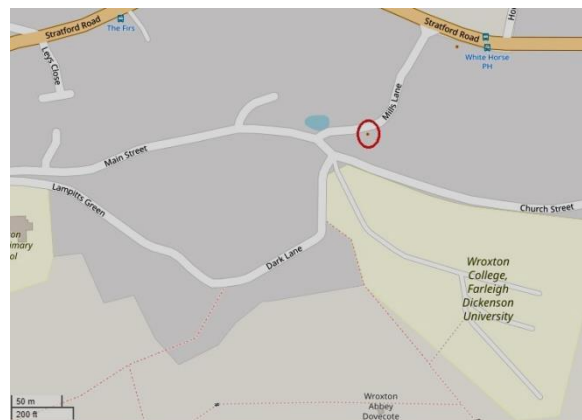

Location © OpenStreetMap contributors

The village of Wroxton lies 5km (3 miles) to the west of Banbury towards the north of the District. The busy A422, the main road from Stratford-Upon-Avon to Banbury, passes through the village to the north on a west east axis. The settlement nestles against the Grade II* Registered Historic Park and Garden of Wroxton Abbey which is primarily situated to the south and east of the village

2.2 Planning Search

A Planning Search of the site was carried out via the LPA Cherwell District Council portal. The scope of this report did not include any planning applications that maybe hardcopy and may only be held in the planning department or archives

Planning Applications (18)

Reduce 3 no. Leylandii in height to approximately 8 - 10 feet

Ref. No: 01/01712/TCA | Status: Application Permitted

Fell Norway Spruce tree

Ref. No: 01/02306/TCA | Status: Application Permitted

6 No. illuminated signs and 6 No. non-illuminated signs (RETROSPECTIVE)

Ref. No: 03/00886/ADV | Status: APPREF

6 No. illuminated signs and 6 No. non-illuminated signs (RETROSPECTIVE)

Ref. No: 03/00887/LB | Status: Application Refused

Seven signs, three lanterns, two bullet lights, one pole sign (as amended by email received on 8 April 2004 (Part Retrospective))

Ref. No: 04/00263/LB | Status: Application Permitted

Seven signs, three lanterns, two bullet lights, one pole sign (as amended by email received on 8 April 2004 (Part Retrospective)).

Ref. No: 04/00267/ADV | Status: Application Permitted

1 No. externally illuminated pictorial sign and 1 No non-illuminated hanging sign (as amended by plans received 01.12.04).

Ref. No: 04/01894/ADV | Status: Application Permitted

1 No non-illuminated hanging sign (as amended by plans received 01.12.04).

Ref. No: 04/01895/LB | Status: Application Permitted

Raise 3 No. existing chimney stacks to 1.8 metres above nearest ridge line.

Ref. No: 04/02118/LB | Status: Application Withdrawn

Raise 3 No. existing chimney stack to 1.8 metres above nearest ridge line

Ref. No: 04/02129/F | Status: Application Withdrawn

Reduce crown of 1 No Cherry tree by 30%

Ref. No: 05/01945/TCA | Status: Application Permitted

Erection of lean-to to front elevation.

Ref. No: 07/00896/LB | Status: Application Refused

Erection of lean-to to front elevation.

Ref. No: 07/00897/F | Status: Application Refused

Erection of hexagonal timber shelter

Ref. No: 07/01648/F | Status: Application Permitted

Replace existing block cut patterned ridge with plain flush ridge

Ref. No: 10/01273/LB | Status: Application Permitted

Internal fire precautions work

Ref. No: 11/00280/LB | Status: Application Refused

T1 x Flowering Chery - Fell T2 x Lawson Cypress - Fell T3 x Leyland Cypress Hedge - Fell

Ref. No: 13/00191/TCA | Status: Split Decision

Removal of fascia lettering, directional board signage and hanging signs from all elevations including associated modern lighting and brackets. Making good, like for like following removal.

Ref. No: 13/01827/LB | Status: Application Withdrawn

Building Control Applications (2)

Building sharing supply with dwelling Extension to circuit (in kitchen special location/ installation)

Ref. No: CP/NICEIC/01041/2008 | Status: Building Work Completed

Dwelling house Kitchen Ring/ radial power circuit

Ref. No: CP/NICEIC/00154/2009 | Status: Building Work Completed

2.2.1 The North Arms was registered as an Asset of Community value on 20th October 2016 ACV037.

Public house closed in 2013 and sold by Greene King Brewery.

Assets of Community Value - ACV037, The North Arms, Wroxton, Wroxton	
Home > Online directories > Assets of Community Value > ACV037, The North Arms, Wroxton, Wroxton	
Record details	
Asset Name	The North Arms, Wroxton
Nature of Asset	Public House
Asset Address	Mill Lane, Wroxton OX15 6PY
Date of listing as a Community Asset	20-Oct-16
Date for removal from list (5 Years from listing)	20-Oct-21

2.3 Background to Listed Building Consent and the NPPF

Since the introduction of Planning Policy Statement 5 (PPS5): Planning and the Historic Environment in March 2010, any application affecting heritage assets needs to include an assessment of the significance of the asset and its setting. This is now outlined in the National Planning Policy Framework with para.189 of particular relevance.

Listed building consent is required for all alterations to listed buildings and their interiors irrespective of their grade or category of listing. It is also required for alterations to any object or structures which lies within the grounds of curtilage of a listed building and which was constructed before 1 July 1948. This may be taken to include Garden walls, sundials, dovecotes and other such objects and structures as well as buildings, which are ancillary to the principal building, not separated from it, and were so at the time of listing. Listing celebrates a building's special architectural and historic interest, it is under the consideration of the planning system, so that it can be protected for future generations. The older a building is, the more likely it is to be listed. All buildings built before 1700 which survive in anything like their original condition are listed, as are most of those built between 1700 and 1840. Particularly careful selection is required for buildings from the period after 1945. Usually a building must be over 30 years old to be eligible for listing.

Categories of listed buildings:

Grade I buildings are of exceptional interest, (2.5% of listed buildings)

Grade II* buildings are particularly important buildings of more than special interest; (*5.5% of listed buildings)

Grade II buildings are of special interest; (92% of all listed buildings), the most likely grade of listing

for a home owner.

Listing covers a whole building, including the interior, unless parts of it are specifically excluded in the list description. It can also cover other attached structures and fixtures, later extensions or additions and Pre-1948 buildings on land attached to the building. (In the planning system, the term 'curtilage' is used to describe this attached land.)

Because all listed buildings are different and unique, what is actually covered by a listing can vary quite widely. [Historic England]

It is a common misconception that only the exterior of a building is protected; the protection extends to both the interior and exterior of the property. Protection also extends to curtilage-listed buildings or structures. The List description itself is only a guide. "The entry in the statutory list contains a description of each building to aid identification. This can be just a description of the building and its features, but more modern entries will set out a summary of the assessment of special interest in the building at the time of designation. However, descriptions are not a comprehensive or exclusive record of the special interest or significance of the building and the amount of information in the description varies considerably."

[Reference <https://historicengland.org.uk/advice/hpg/has/listed-buildings/>]

Section 66 Planning Listed Buildings and Conservation Areas Act 1990 England imposes " a general duty as respects listed buildings in exercise of planning functions" and " in considering whether to Grant permission for development which affects a listed building or its setting, the LPA or, as the case may be the Secretary of State shall have special regard to the desirability of preserving the building or setting or any features of special architectural or historic interest which it possesses" It is against the law to make changes to a listed building without listed building consent .

2.4 The Sites Listed Building Descriptions

North Arms Public House & Outbuilding [separately listed]



View from Church Lane of North Arms



View from Mills Lane of North Arms

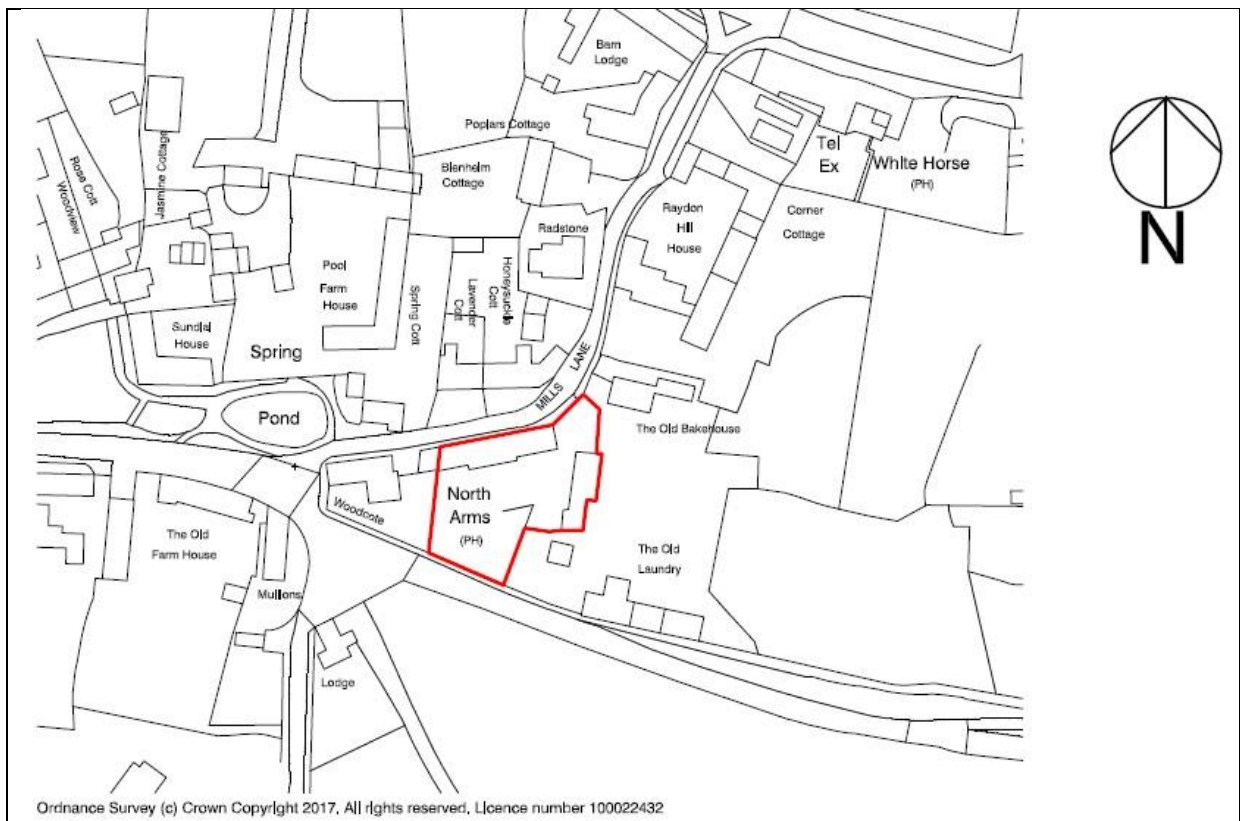

OS Map Location of the site boundaries of Listed Buildings North Arms and Outbuilding

Entry Name: The North Arms Public House
Listing Date: 8 December 1955
Last Amended: 20 September 1988
Grade: II
Source: Historic England
Source ID: 1185033
English Heritage Legacy ID: 244799
Location: Wroxton, Cherwell, Oxfordshire, OX15
County: Oxfordshire
District: Cherwell
Civil Parish: Wroxton
Built-Up Area: Wroxton
Traditional County: Oxfordshire
Lieutenancy Area (Ceremonial County): Oxfordshire
Church of England Parish: Wroxton with Balscote
Church of England Diocese: Oxford

WROXTON MILLS LANE

SP4040-4140

(East side)

10/242 The North Arms Public House

08/12/55 (Formerly listed as The North

Arms Public House and
outbuilding)

GV II

House and cottage now public house. Late C17 with early C19 refacing to left part. Ironstone ashlar and coursed ironstone rubble. Steeply pitched thatched roofs with renewed brick ridge and end stacks. 2-unit plan plus two single-unit parts on right. Main building, 2 storeys plus attic, the rest single storey plus attic. 4-window range altogether. 4 entrances have renewed plank doors with stone flat arches or wood lintels. Main part has 2, imitation wood mullioned and transomed windows on the ground floor and 2 originally 3-light wood mullioned and transomed windows on the first floor, with renewed wood casements. Two roof dormers have 3-light wood casements. Stone coped gable on left with moulded kneeler. Arris on left chamfered up to first floor left. Sundial above doorway.

Right part has renewed casements and an imitation stone mullioned and transomed window with chamfered wood lintels. Interior has fireplace with bressumer and chamfered beams.

(VCH: Oxfordshire: Vol IX, p171)

Listing NGR: SP4146841782

Outbuilding 5 Metres East of the North Arms



Stable Outbuilding Front Elevation



Stable outbuilding Side Elevation

Entry Name: Outbuilding Approximately 5 Metres East of the North Arms Public House

Listing Date: 8 December 1955

Last Amended: 20 September 1988

Grade: II

Source: Historic England

Source ID: 1046788

English Heritage Legacy ID: 244800

Location: Wroxton, Cherwell, Oxfordshire, OX15

County: Oxfordshire

District: Cherwell

Civil Parish: Wroxton

Built-Up Area: Wroxton

Traditional County: Oxfordshire

Lieutenancy Area (Ceremonial County): Oxfordshire

Church of England Parish: Wroxton with Balscote

Church of England Diocese: Oxford

WROXTON MILLS LANE

SP4040-4140

(East side)

10/243 Outbuilding approx. 5m E of 08/12/55 the North Arms Public House

(Formerly listed as The North Arms Public House and outbuilding)

GV II

Stable now outbuilding. C18. Coursed, squared ironstone with corrugated iron roof. C20 doors with stone lintel. 2-light wood casement to left with wood lintel. Loft door above entrance. Nesting boxes. Interior not inspected. Included for group value.

Listing NGR: SP4149441778

2.5 Other Listed Buildings

There are 70 listed buildings within Wroxton Conservation Area boundary. Most are GDII but some buildings and structures particularly associated with Wroxton College, itself designated GDI, are GDII*. Below is a map showing the most nearby other listed buildings, circled green, neighbouring the North Arms [outlined in red.]

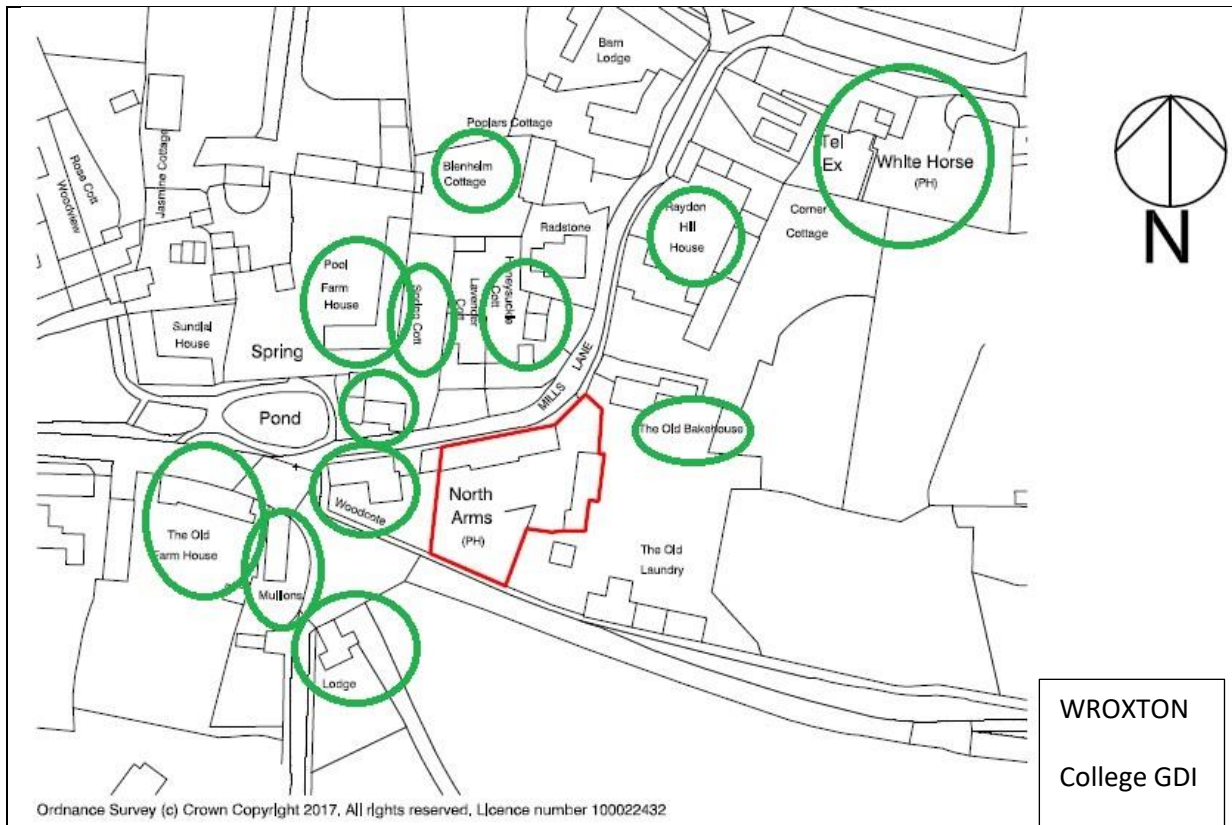

Location plan with surrounding listed buildings marked

List of Listed Buildings surrounding the North Arms

- II [Raydon Hill House](#)
- II [Barn Approximately 3 Metres East of Raydon Hill Farmhouse](#)
- II [Bleinheim Cottage](#)
- II* [Gateway, Gates, Wall and Attached Lodge to Wroxton College](#)
- II [Honeysuckle Cottage](#)
- II [Mullions](#)
- II [Pool Farmhouse](#)
- II [Spring Cottage](#)

[II The Old Bakehouse](#)**[II The Old Farmhouse](#)****[II White Horse Public House](#)****[II Woodcote](#)****[I Wroxton College and Attached Walls and Steps](#)**

<https://britishlistedbuildings.co.uk/england/wroxton-cherwell-oxfordshire#.XFDBDxKnxxB>



cc-by-sa/2.0 - Wroxton College (Formerly... by Ian Rob - geograph.org.uk/p/4322023)
Front Elevation GD I Wroxton College- **Fairleigh Dickinson University**

2.6 Conservation Area

The conservation area boundary includes the Historic Park and Garden of Wroxton Abbey. All properties within the village are within the conservation area boundary. Due to the inclusion of the Historic Park and Garden within the conservation area boundary, the conservation area for Wroxton physically abuts the conservation area for the adjacent village of Drayton. The boundary between the two conservation areas is the Sor Brook which runs in a north-south axis and also forms the eastern boundary of the Historic Park and Garden. [Wroxton Conservation Area Appraisal 2017]

- District Council – Cherwell District Council North Oxfordshire
- Village is within Wroxton Conservation Area, first designated in September 1977 and a recent Conservation Area Appraisal was undertaken in August 2017
- Adopted Cherwell Local Plan 1996 and Cherwell Local Plan 2011-2031 (Approved Document 20 July 2015).
- Article 4 Directives -The existing conservation area boundary is drawn to include the whole village, including the whole area covered by the Registered Historic Park and Garden of Wroxton Abbey. Wroxton for many years had an Article 4 Direction that related to the historic core and removed additional 'permitted development rights' over and above the extra restrictions of a conservation area designation. The Article 4 direction is no longer valid and is being reconsidered as part of the management plan for the Conservation Area.

[Wroxton Conservation Area Appraisal 2017]

3 Setting and Vistas

3.1 Historical Background -Wroxton

The Settlement

The parish was once traversed by ancient trackways and by the Saltway, a route from the Worcestershire saltworks to London. It has not yet been possible to prove the existence of a Roman road, but there are slight traces of a Roman settlement. The earliest spellings suggest an etymology Wroces Stan or the Buzzards' stone. The medieval village was no doubt dominated by the Augustinian priory founded there in the 13th century. In 1536 the Crown granted a 21-year lease of the site and demesne of the two manors of Wroxton and Balscott to William Raynesford of Wroxton. In 1537 Thomas Pope, the Treasurer of the Court, obtained a reversion of Raynesford's lease in return for an exchange of land and some money, and a grant in fee of the two manors in exchange for Clapton manor (Northants.). In November Pope bought out the remainder of Raynesford's lease for £200 and thus acquired full possession of the manors and demesnes. In 1551 he gave his brother and heir John a 99-year lease of the manors. Shortly afterwards Thomas Pope conceived the idea of founding Trinity College, Oxford, and in 1554 he conveyed the manors for ever to the new foundation. The village has also been made memorable by its connexion with Wroxton Abbey, which was built on the priory site in the early 17th century, and with the distinguished members of the Pope and North families who have resided there. The extent of the village before the 18th century is unknown, but it can never have been large. In 1738 the vicar returned 50 houses. As freeholders were never either numerous or prominent at Wroxton from the 14th to the 19th centuries, the bulk of the land was held by the lord of the manor, who was in possession of demesnes, abbey lands, mills, and extensive copyholds in the open fields. In 1768 a survey disclosed the following situation: Trinity College held 1,183½ a., comprising abbey inclosures (342 a.), abbey lands (293¼ a.), and other lands (547¼ a.) Despite close proximity to Banbury with its weaving and other industries, Wroxton seems to have been chiefly an agricultural village before the 19th century.

In 1851 there were only 2 large farms of 270 a. and 310 a. and 14 others of 50 a. to 120 a. The rest were small-holdings — 12 of 40 a. and under. The large farms employed 7 and 12 labourers each. One miller and farmer combined had 7 labourers. In the 1860s the land was mainly under arable though the soil was better suited to grass and a 5-course rotation was used. Many sheep were kept and fed on turnips in the winter. Labour conditions were somewhat better than elsewhere. Colonel North employed no boys under 12 years, no girls at all, and women only at special times. Though there was overcrowding in the cottages there was a good water supply and all married couples had an allotment of ¼ a. from Colonel North.

Population

In 1377 148 men and women contributed to the poll tax, but many died from plagues shortly afterwards. A suit roll of 1569 lists 70 names, 12 of them of widows. The parish register for 1563–71 shows a continued, if less marked, increase. The Protestation Return of 1641 recorded an adult male population of 107, and in 1676 there were 219 communicants of 16 and over, both of which suggest a total population of c. 330. After a period of stability the population began to rise about 1740; the rate of growth was highest, however, in the second, third, and fourth decades of the 19th

century. The total population was 613 in 1801, 652 in 1811, and 792 in 1821. By 1841 it had reached a peak of 819. It fell steadily to 562 in 1901. In 1961 it was 598. The most recent census returns indicate that in 2011 the population was 546.

Economy

Wroxton adhered to a 2-field system to a comparatively late date: in 1537 there is mention of Town Field and in 1571 of South Field or South Side of Wroxton Field. Along with the open fields was the usual accompaniment of meadow lands, in small lots in the Great and Little Meadow. It is evident that originally these parcels had been allotted annually, but by the 16th century the lots were firmly attached to each copyhold. The tenants of Wroxton alone had the right to keep about 1,300 sheep, and a series of orders issued by the manorial court in 1580 and the almost universal possession by the tenants of sheep-houses or sheep-cotes shown in the terrier of 1604 indicate that they were fully exercising this privilege in the late 16th and early 17th centuries. Comparatively little is known about the cottagers: a rental of Wroxton and Balscott of 1525 shows 10 cottagers and 25 tenants; an undated rent roll of the late 16th century or early 17th century 15 cottagers, 27 copyholders, and 4 leaseholders. It was alleged in 1650 that the Popes had converted their copyholds into leaseholds during the Civil War, and had turned their tenants out so as to let their land and houses to others. The government was petitioned to restore the former position, but the outcome of the suit is not known. By the early 18th century the term 'day labourer' was being used: a suit roll of 1718 lists 31 names, presumably tenants, and 21 day labourers. The 18th century also saw a renewed interest in forestry. The Popes had done a great deal in this respect. When Sir Thomas Pope leased Wroxton Abbey to his brother John in 1551, the latter covenanted to plant within 20 years 2,000 oaks and 1,000 elm and ash trees, and to make the copyholders plant also.

The final inclosure of the open fields did not come until 1804. In the early 19th century the majority of the inhabitants of Wroxton, even if they did not farm land themselves, had occupations dependent on farming. The parish registers (1813–57) indicate that about half the population were labourers, and that there were the usual rural craftsmen such as blacksmiths and carpenters. In the 1851 census, besides such craftsmen, there were 2 masons, a lacemaker, a glover, a cork-seller, 2 plush-weavers, and a linen-weaver.

[<https://www.british-history.ac.uk/vch/oxon/vol9/pp171-188>]

3.1.2 Historical Area Assessment-Location and Landscape Setting

Building Types in Wroxton

The buildings are primarily of a simple local vernacular, constructed in coursed rubble ironstone with steep roof pitches overlaid with thatch, or in a smaller number with slate or tiles. The buildings are to a simple rectilinear plan form and lined adjacent to the road, in most cases with ridges parallel to the road, but in others perpendicular with the gable fronting the road creating a gabled land structure similar to burgage plots. Most of these houses date from the 17th and 18th Centuries.

[Wroxton Conservation Area Appraisal 2017]

Quarrying

Lower Jurassic Lias Group Marlstone Rock Formation

Marlstone-Marlstone, also known as Hornton Stone or Banbury ironstone is an iron-rich limestone up to 10 metres thick, quarried from the Middle Lias (Lower Jurassic) of north Oxfordshire. It weathers to a distinctive golden orange/brown colour but can appear bluish green when unweathered. It contains abundant shelly fossils, usually clusters of brachiopods. Both freestone and a rougher, more rubble stone were quarried, so that Marlstone could be used for both walls and dressings in both small and large buildings. However it is susceptible to weathering and spalling, so that it has sometimes been later replaced with a more durable ooidal limestone.



The distinctive warm-coloured Marlstone characterises the cottages in many villages such as Great Tew, Deddington, Adderbury, Bloxham, **Wroxton**, Hook Norton and Hornton, as well as churches such as St. Mary's in Adderbury and stately houses such as Broughton Castle and Chastleton House. In Oxford its deep colour led to use in ornamental work on buildings such as the University Museum (1859) and the Christ Church Meadow Buildings (1862).

In Wroxton small scale quarrying had been carried out throughout the 18th century and probably before, for local building stone but without access to the river and canal network the growth of quarrying on any scale was prevented due to high transport costs (Cherwell District Council, 1996).

At the end of the 19th century came the large-scale exploitation of ironstone quarrying. Since 1917 the Oxfordshire Ironstone Co. Ltd. has been the lessee, and Christ Church and Trinity College have leased ground as the need for it arose. The company extracts ironstone at the rate of 30,000 tons an acre for conversion into steel; it works 45 yards at a time, preparing a third, digging a third, and restoring the level of a third. In 1963 it was employing 135–140 men, but at the height of the steel boom had employed 200. The product was sent to South Wales and to the Brinberg steel works at Wrexham (Denbighshire)

[<https://www.british-history.ac.uk/vch/oxon/vol9/pp171-188>]

[Wroxton Conservation Area Appraisal 2017]

[Strategic Stone Study A Building Stone Atlas December 2017]

3.2 Current Setting Photographic Views



Village Pond looking towards Mills Lane



Spring Cottage and Woodcote, North Arms behind



Spring Cottage



Mullions stone mullioned windows and coursed squared ironstone by gates to Wroxton Abbey



View from Mullions to North Arms



View up Mills Lane Gable end of North Arms

4 Assessment of the North Arms Mills Lane Wroxton

4.1 Scope of Assessment

This report contains a brief analysis of the significance of the history and character of the building/structure known as **The North Arms Mills Ln, Wroxton, Banbury OX15 6PY**

Any justification for proposed works and their impact on the special character of this listed building or structure and its setting could be issued as a separate document but should be read in conjunction and always with reference to this Assessment.

4.2 Map Regression

An analysis of historic mapping and available historical photographs [See Section 4.4] was carried out by RDA. With available maps of any detail from the 19th century it would appear that the plan form of the buildings has changed little. Sometime between the 1930s and 1960s the single storey building attached to the West elevations now a toilet block has undergone alterations. A gap where a building once stood appears, in the C19, to belong to neighbouring Woodcote.

Extracts from Maps



1892

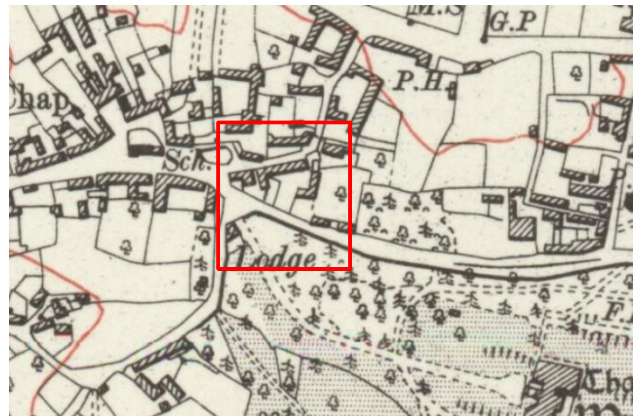

1923

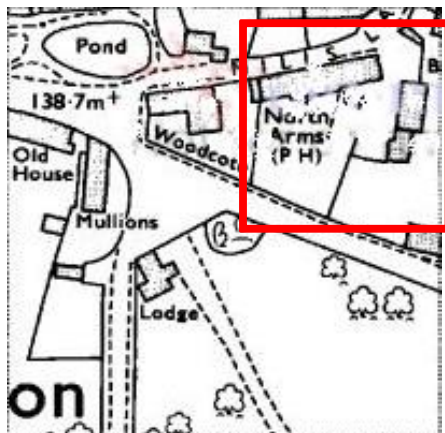

1972-78



2019

4.3 Historical research

A brief historical analysis of past owners and events was carried out by RDA via a desk based internet search, correspondence with local archives via email and their websites; Wroxton Village Website and Banbury History Society. RDA also carried out a National Archive of Historical Newspapers search. Historical information from the C20 was provided by the current owners.

Trinity College, Oxford owned a number of buildings in the village including Wroxton Abbey and the North Arms. Tenants of the North Arms held copyhold ownership. Much of the following list was obtained from a short history compiled by the Fairleigh Dickenson University Librarian. Relevant dates have been included in the list and some additions have been included from RDAs own research. [Courtesy Wroxton College Librarian *North Arms Heritage unpublished Report*]

Chronological List

1666- Fire in Wroxton destroys most of the village which comprised timber framed and thatched cottages. [Woolacott, M (2018), The Great Fire of Wroxton]

1738- Vicar's report lists 50 houses in village VCH 'Parishes: Wroxton', in A History of the County of Oxford: Volume 9

1753- Turnpike built to ease traffic through village and White Horse comes into existence as a result. VCH 'Parishes: Wroxton', in A History of the County of Oxford: Volume 9

1775-1783- Frederick Lord North - MP for Banbury 13 times, Chancellor, First Lord of the Treasury and Prime Minister presides over the loss of American Colonies when America declares independence on 2nd July 1776 VCH 'Parishes: Wroxton', in A History of the County of Oxford: Volume 9

1792 George Lord North acceded to his father's title and took over the constituency

1841 – Mr C Pearson “*That well known public house at Wroxton, known by the name, the North Arms, now in the occupation of Mr Charles Pearson, may be entered upon at Michaelmas next*’ *Leamington Spa Courier, dated 31st July 1841*

1844 -1st Anniversary Odd Fellows at North Arms Inn Banbury Guardian 1844

1852- William Kalabergo incarcerated in North Arms by Constable William escaped from an attic room by sliding down the roof but was quickly caught by Mr Harris the landlord. Kalabergo was found guilty and was the last person to be hanged publically in Oxford. [Nicola Sly, *Oxfordshire Murders* (Stroud: The History Press, 2010) p.37-42]

1852 - The North Arms had a sitting room, parlour, bar, two kitchens, a cellar, a club room, bedrooms, a brewhouse, a large yard, garden stables and piggeries. Banbury Guardian, Thursday 14th October 1852

1885- Mr W . Harris Landlord Banbury Guardian, 1885.

1892 -Mr Harris left to other premises Banbury Guardian, 4th Mar 1892 Newspaper: Banbury Guardian

1904- Lease transferred from W.G. Rymill to C Neville 23rd Jun 1904 Newspaper: Banbury Advertiser

Heritage Assessment of The North Arms, Mills Ln, Wroxton, Banbury OX15 6PY

1905- Transferred to Mr Taylor Newspaper: Banbury Advertiser

1909- Historic Photograph rear of North Arms Thomas Taylor & Family with B Whitmill Blacksmith

1915 - Lady North dies Wroxton Abbey Newspaper: Banbury Advertiser

1927- Lord North celebrates 90th birthday 5th Oct 1927 Newspaper: Birmingham Daily Gazette

1927- Mr JW Aris extended license hours for Flower Show Banbury Advertiser 1927

1928- Lord North was the Society's president Banbury Guardian, Thursday 7th June 1928

1939- Mr Fred Arris ran the North Arms as a boarding house as well as a pub [Ancestry.com (2013) UK City & Counties Directories, 1776-1946. Available at <https://bit.ly/2MrrWd9>]

1950- The North Arms Friendly Society dissolved in 1950 Banbury Guardian, Thursday 16th November 1950

1950 -Mr Ayriss extension for Whit Monday Banbury Advertiser 1950

1958- Trinity College sold the North Arms in 1958 to Chesham and Brackley Brewers. [Hopkins, Clare. "The North Arms." Message to Andrew Rose. 3rd August 2018. E-mail. Source Wroxton College Librarian]

1973 -a fire in one of the bedrooms damage was confined to the one room. Coventry Evening Telegraph, Saturday 14th April 1973

2013 -Greene King Brewery

2015- Current owners

4.4 Historical Photographs & Analysis

A search for historical photographs was made within the timescale and scope of this report. Sources were found from the Wroxton Village Website, Maureen Woolacott, and old postcards.



C19 postcard Village pond View towards Woodcote and North Arms. *Woodcote was formerly The Black Horse Pub C19 –WWI The room at the end overlooking the pond was used as a garage for many years and was then incorporated into the house.* [Ref Correspondence Maureen Woolacott]



Note in this C19 postcard there is a thatched single storey building intersecting Woodcote and the North Arms attached to single storey stone building with a chimney of North Arms [Now Toilet Block]



Thatched Village 1930s [Courtesy Media Storehouse] Single storey thatched building intersecting Woodcote and the North Arms attached to single storey stone building with chimney of North Arms.



An Image of Wroxton Pond Date created 1930
Courtesy <http://www.british-towns.net/england/midland/oxfordshire/cherwell/wroxton/album/wroxton-pond>

Heritage Assessment of The North Arms, Mills Ln, Wroxton, Banbury OX15 6PY



REAR OF THE "NORTH ARMS"
1909

L to R: Mrs Taylor (Landlords Wife), Mr J Taylor, Tom Taylor, Ida Taylor, B Whitmill (Blacksmith) and Mr Thomas Taylor (Landlord).

Rear of North Arms 1909 Lower Window matching current First floor
[Photo: Courtesy Maureen Woolacott]



Thomas Taylor holding reins Landlord of North Arms
[<http://www.wroxton.org.uk/old%20pictures.htm>]
]



1960s- 1970s North Arms.
Comparison with 1909 photo above the lower windows today have changed and steps to doorway seem reduced. First floor windows remain as they are today and are probably early C19. Note Door entrance to Cottage. [Photo: Courtesy Maureen Woolacott]



1967. Single storey thatched building now removed. Stone single storey stone building without chimney may have been when this building was rebuilt and is now the toilet block

4.5 Phasing of Main Buildings & Stable

C17 House and cottage/s with separate C18 stable outbuilding.

Main House most likely converted into a Public House sometime in the early C19. Main House/Pub has a C20 single storey unit remodelled from C19 unit to the west recently used as the Public House Toilets. The House with cottage, now one building, may have been originally in the C17 a single lobby entrance dwelling accessed from the South with stable and yard. *'In the 17th and early 18th Centuries the lobby entrance were based on two main living rooms and some on three. Some had internal staircases while some had staircase projections'* [Brunskill ; Traditional Buildings of Britain p.64 and p.66] However there is some evidence that this was once two dwellings, each has substantial chimney breasts and stacks serving ground floor rooms. It is difficult to be conclusive as all the main entrance doors have changed over time and there are no ground floor historic staircases. Access to first floor is via a C20 staircase from the 2 storey unit to the east. The external footprint and plan form of the two main buildings are otherwise unaltered and the main two buildings are both thatched over possible raised crucks/ principal trusses. It is difficult to assess whether the smaller 2 storey unit attached east with thatched roof is of a later date as much historic fabric is concealed, as recent use has been as kitchens and cold store over. Evidence from the east gable end would suggest this section to be at least C18.

The main C18 Stable Outbuilding plan form remains largely unaltered although the roof structure has been lost and replaced with C20 timber and a corrugated iron roof.

Annotated Surveyors Floor Plan coloured for Phasing; do not scale off this drawing

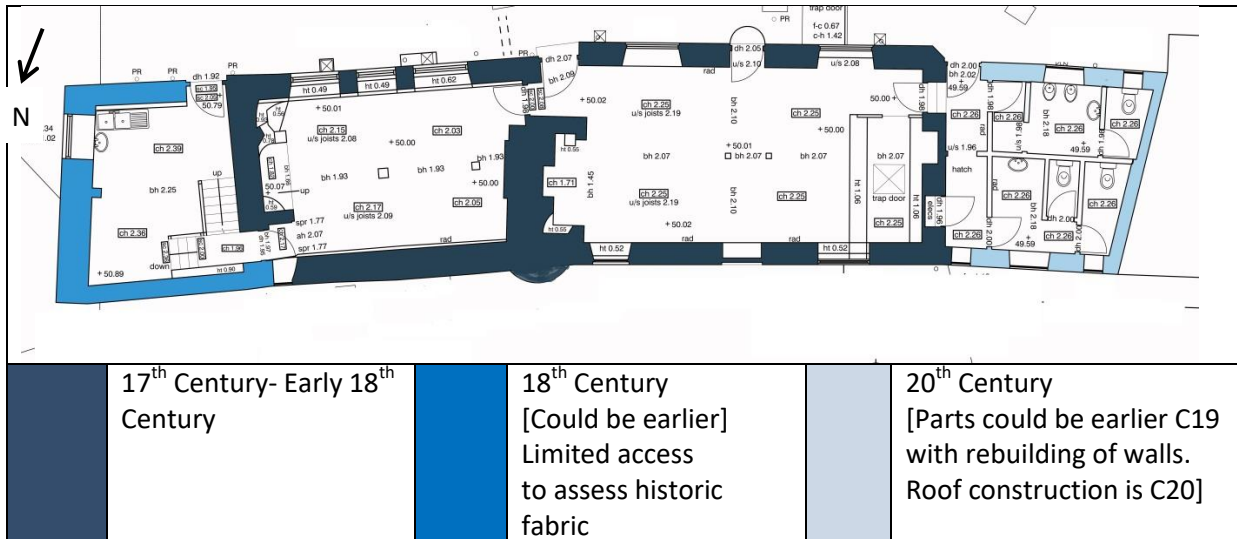

[Original Plan Courtesy Brear Associates Surveyors]

5. Current Photographic Record and Descriptions Building Recording Level 1-2 The North Arms with Significance Levels

RDA assessed the North Arms to an equivalent of a Level 1-2 Building Recording Photographic Survey with some analysis of the phasing and significant interior details by surveying and using appropriate books and websites. [Ref Understanding Historic *Buildings A Guide to Good Recording Practice Historic England* May 2016]

A Level 1 Building Recording, [Ref Understanding Historic *Buildings A Guide to Good Recording Practice Historic England* May 2016]

A Level 1 is essentially a basic visual record, supplemented by the minimum of information needed to identify the building's location, age and type. This is the simplest record, and it will not normally be an end in itself, but will be contributory to a wider study. Typically it will be undertaken when the objective is to gather basic information about a large number of buildings – for statistical sampling, for area assessments to identify buildings for planning purposes, and whenever resources are limited and much ground has to be covered in a short time. It may also serve to identify buildings requiring more detailed attention at a later date. Level 1 surveys will generally be of exteriors only, though the interior of a building may sometimes be seen in order to make a superficial inspection and to note significant features.

As any future proposals may affect the interior RDA assessed the Building for significance at an equivalent of a Level 1-2

LEVEL 2

This is a descriptive record, made in similar circumstances to Level 1 but when more information is needed. It may be made of a building which is judged not to require a more detailed record, or it may serve to gather data for a wider project. Both the exterior and interior of the building will be seen, described and photographed. The examination of the building will produce an analysis of its development and use and the record will include the conclusions reached, but it will not discuss in detail the evidence on which this analysis is based. A plan and sometimes other drawings may be made but the drawn record will normally not be comprehensive and may be tailored to the scope of a wider project [Ref Understanding Historic *Buildings A Guide to Good Recording Practice Historic England* May 2016]

In order to identify the significance of a place, it is necessary first to understand its fabric, and how and why it has changed over time; and then to consider: who values the place, and why they do so; how those values relate to its fabric; their relative importance; whether associated objects contribute to them; the contribution made by the setting and context of the place; how the place compares with others sharing similar values. [Ref Conservation Principles English Heritage/Historic England p21]

A significance level has been added for guidance based on Conservation Principles, English Heritage, 2008 p72 <https://historicensland.org.uk/images-books/publications/conservation-principles-sustainable-management-historic-environment/>

KEY to Significance Levels

HIGH	Elements and elevations are historically and architecturally significant
MEDIUM	Elements and elevations are later additions but some may have historical, architectural, community significance
NEUTRAL	May need further analysis
LOW	These elements /elevations are low and or have a negative impact to the historic fabric.

5.1 Exterior Main Buildings**Photo South Elevation.**

Toilet Block

Early C19 windows

Sundial

Former
EntranceEntrance to
End building
and stairs

Description SOUTH ELEVATIONS

Main House/former recent Public House, with single storey Toilet Block to left side; slate roof over stone elevations rebuilt; C20 plank entrance door.

Main House/former recent Public House 2 storeys plus attic; thatched roof over possible raised C17 cruck principal trusses, inserted 2 roof dormers have 3 light C19 frames /C20 wooden casements ; stone coped gable, moulded kneeler with chamfered arris; remodelled frontage using ironstone ashlar and stone lintels. FF windows; 3 light wood mullioned and transomed probably of early C19 origins. GF Central door with sundial above was the main entrance to Public House probably in the C19 and in 1909[Photo evidence Section 4.4] This C20 plank door is currently blocked from inside and the concrete steps have been replaced since 1909 when they once appeared to be stone. There is a hand water pump outside this door. The GF windows have early C19 stone lintels, but the windows are C20. The original C19 at GF appear to have been the same as the FF [photo evidence Section 4.4] To the right is a further GF entrance door that may have been the position of the C17 Lobby Entrance. This door has stone lintel and graffiti inscribed on the left door jamb, date 1833, and initials WS. The door is C20 plank.

East of the main building is a further 2 storey building attached; thatched roof over x1 raised central cruck principal. X2 iron wall anchor plates. One window opening at eaves/attic that maybe of some C18/C19 origins. Below this is a replacement window in possibly an earlier frame, and a painted timber lintel of much earlier date. There are further x3 window openings with timber lintels containing replacement C20 frames. The central window was once a door to the Cottage[Photo evidence Section 4.4]

East of this, attached, is the lower 2 storey unit with thatched roof. Evidence of C20 stone repairs and mortar, with a C20 door and frame that leads to current kitchen.

A few Photo Details of Exterior Elevations

Hand water pump outside central door that is blocked from inside.



Sundial detail above Central Door



Example of Window openings with timber lintels



One window opening at eaves/attic that maybe of some C18/C19 origins.



GF entrance door has stone lintel and graffiti inscribed on the left door jamb date 1833 and initials WS. The door is C20 plank. Photographic Scale 10cm

Significance Levels

LEVEL	Elements/ Fabric	REASON
HIGH	<ul style="list-style-type: none"> All main structural elevations are significant. C19 Stone lintels Remaining lime pointing to stonework. Graffiti on door jamb X2 FF Mullion and transom windows 	GDII Listed Building Phasing/evolution Materials and phasing Historical & Phasing Phasing
MEDIUM	<ul style="list-style-type: none"> Dormer windows in Eaves Sundial Hand Pump 	Later Phasing Historical Historical & Communal
NEUTRAL	<ul style="list-style-type: none"> Toilet Block structure/ Rebuilt 	
LOW	<ul style="list-style-type: none"> All C20 Plank Doors and C20 window frames to GF[See description] Hard Cement pointing repairs Reproduction lighting Rainwater goods and service pipes Untidy Electrical wiring 	Not of Architectural merit Not traditional materials Not of Architectural merit Not of Architectural merit [Although replacements should be cast iron] Detracts

Photo NORTH ELEVATIONS

Photo North/East Elevations to Mills Lane

Description NORTH ELEVATIONS -From bottom of Mills Lane

Single storey [Toilet Block] stone/rebuilt? Remodelled on earlier C19 building that had a chimney [photo evidence Section 4.4] Toilet block with slate roof; x3 Crittall windows circa 1960.

Main House /Public House ; 2 storeys plus attic room thatched roof over X2 [probably] raised cruck principals. Central early C19 door entrance with dressed stone lintel with keystone; door C20 with reproduction C20 canopy porch over. Right hand side GF window with timber lintel and likely early C19 shutters/concrete sill/ C20 window pane. FF; C20 window above central door probably a C19 opening with stone keystone. GF ; Left hand side window opening with timber lintel and a concrete sill; to left of window a stone half circular built bread oven with a C20 slate covering.

Attached to main house, a 2 storey stone [cottage] with thatch roof over X1 raised cruck principal. Stone wall has X2 Iron wall anchor plates. Evidence in GF wall of a previous door opening to Mills Lane with timber lintel and evidence of possible former window opening central FF. Far end; a small GF crittall window.

Attached to this, a further thatched and stone 2 storey semi basement building [former recent Kitchen and Cold Store] No openings on Mills Lane, and evidence of repairs to walls in C20 cement pointing.

A few Photo Details of Exterior Elevations



Central early C19 door entrance with dressed stone lintel with keystone, window with timber lintel and likely early C19 shutters



Shutters; possible early C19
Concrete sill/ C20 window pane.





Stone half circular built bread oven with a C20 slate covering; Stone wall has X2 Iron wall anchor plates. Evidence in GF of a previous door opening with timber lintel and evidence of possible former window opening central FF

Significance Levels

LEVEL	Elements/ Fabric	REASON
HIGH	<ul style="list-style-type: none"> All main structural elevations are significant. C19 Stone lintels Remaining lime pointing to stonework. Bread Oven Previous door opening with timber lintel 	GD II Listed Building Phasing/evolution Materials and phasing Phasing/evolution Phasing/evolution
MEDIUM	<ul style="list-style-type: none"> Shutters; possible early C19 Anchor Ties Iron brackets holding guttering 	Later Phasing Later Phasing Later Phasing
NEUTRAL	<ul style="list-style-type: none"> Toilet Block structure/ Rebuilt 	
LOW	<ul style="list-style-type: none"> C20 Front Door and Canopy porch Hard Cement pointing repairs Reproduction lighting Rainwater goods and service pipes Untidy Electrical wiring Slate roof covering Bread Oven 	Not of Architectural merit Not traditional materials Not of Architectural merit Not of Architectural merit Detracts Not of Architectural merit

Photo WEST GABLE ELEVATIONS

Photo West Elevations to Mills Lane

Description WEST ELEVATIONS -From bottom of Mills Lane

Gable end, and walling of the single Toilet block with slate roof that would appear to have been rebuilt in the 1960s. End gable wall is painted brickwork.

Gable end of The North Arms; Ironstone with ashlar stone quoins; rebuilt brick chimney stack; C20 Lettering North Arms.

Significance Levels

LEVEL	Elements/ Fabric	REASON
HIGH	<ul style="list-style-type: none"> All main structural elevations are significant. 	GD II Listed Building
MEDIUM		
NEUTRAL	<ul style="list-style-type: none"> Toilet Block structure/ Rebuilt 	
LOW	<ul style="list-style-type: none"> Hard Cement pointing repairs 	Not traditional materials

Photo EAST GABLE ELEVATIONS

Gable end of Thatched stone building; x2 storey ; semi basement

Description East ELEVATIONS -From Top of Mills Lane



Iron spear headed brackets on pintles



mortice and tenoned pegged joints

Gable end of thatched stone building; x2 storey semi basement; single unit [used most recently as Kitchen with Cold Store above] Central loft door possibly early C19. Door frame with timber lintel has mortice and tenoned pegged joints, and door, possibly C19 is hung with iron spear headed brackets on pintles. Above this door is a lancet window, probably for ventilation. GF ; Right grille for Air Con and window opening and further window C20.

Significance Levels

LEVEL	Elements/ Fabric	REASON
HIGH	<ul style="list-style-type: none"> All main structural elevations are significant Central loft door/frame possibly early C19. Poor Condition 	GD II Listed Building Phasing/evolution
MEDIUM		
NEUTRAL		
LOW	<ul style="list-style-type: none"> Hard Cement pointing repairs C20 Window & Air Con Grille 	Not traditional materials Not of Architectural merit

5.2 Interior: Main Building and note of significant features

5.2.1 GROUND FLOOR: CELLAR

Annotated Surveyors Floor Plan, Rooms Labelled for reference; do not scale off this drawing

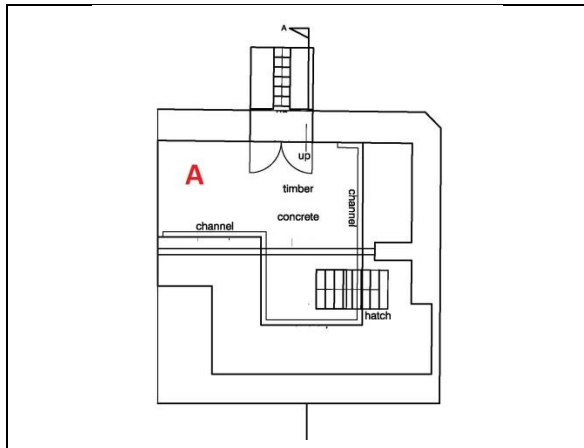

Plans Courtesy Brear Associates Surveyors

Photo



Cellar accessed via timber ladder steps from a floor hatch

Photos



Shoot for Beer Barrels



Sunken basin

Description

Cellar accessed via timber ladder steps from a hatch in floor by the Bar on the GF. Walls brick; ceiling boarded. Concrete floor with sunken basin edged with bricks, and ceramic white tiling. Shoot for beer barrels. Cellar would appear to have been excavated and made, probably in the C19 when the domestic house/dwelling/s became a Public House.

Significance Levels

LEVEL	Elements/ Fabric	REASON
HIGH		
MEDIUM		
NEUTRAL	Ceramic Basin Barrel shoot	Community interest Historical Association as a PH
LOW		

5.2.2 GROUND FLOOR

Annotated Surveyors Floor Plan, Rooms Labelled for reference; do not scale off this drawing

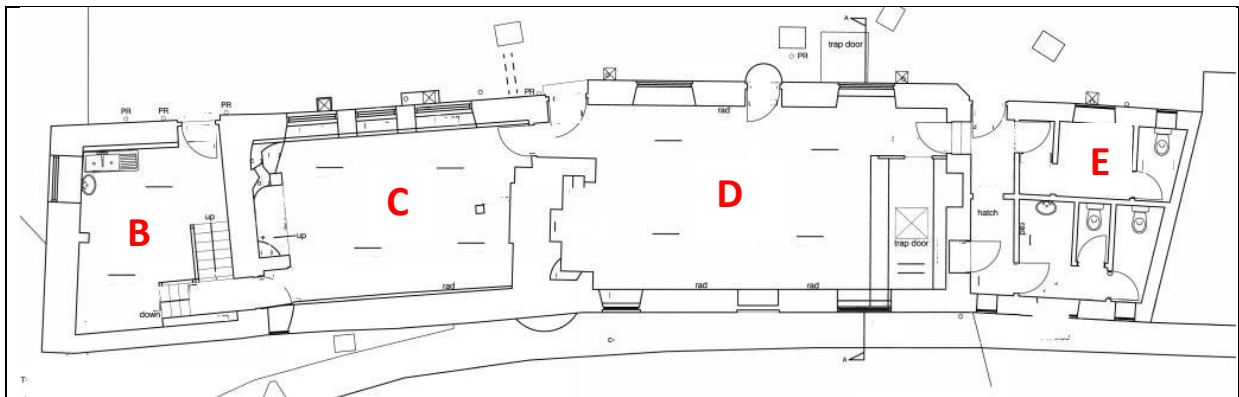

Description GF- Starting from Room B Significant observation details Ground floor {B C D E}

Entrance to house is from the yard via a C20 plank door to 2 storey [east end] building, now used as Kitchen with Cold store over. Leads down via steps to passage lit by small Crittall window to Room C; [former Dining Room PH] Ground floor of C17 Cottage.



ROOM C View West



ROOM C View East

C20 tiled floor to solid floor; C20 plaster probably over historic fabric; X3 recessed windows to south. Central window; was a former entrance door [historic photo evidence] Central timber beam supported on probably two C20 posts, fabric concealed.

Heritage Assessment of The North Arms, Mills Ln, Wroxton, Banbury OX15 6PY

Ceiling is exposed timbers to one half of room to the east gable end; chimney stack stone; Inglenook Fireplace; bressemer beam; evidence of possible bread oven, now altered ; stone niches and ledges.

Photos of Significant details



ROOM C Fireplace



ROOM C Ledge/ former Bread oven?

A C20 door, and probably a C20 opening, leads to **ROOM D** beside a large chimney stack and the outside entrance door that has the graffiti inscription on the outside jamb dated 1833 [See Exterior description]This Room is former PH bar; X2 windows to south; X2 windows to north ; Mills Lane.



ROOM D View West



ROOM D View East

ROOM D contd

Solid concrete floor; C20 floor covering; Wall finishes of C20 plaster, probably covering historic fabric. Evidence that this Room was once divided and had a dividing wall between the entrances south to Yard, and north on Mills Lane, both of which are now blocked from the inside. X2 chamfered timber posts. The Lath and plaster ceiling towards fireplace has a central chamfered beam with ogee stops; exposed ceiling timbers joists that are also chamfered, indicating a more prestigious room. *"Ogee stops with chamfered beams usually date from 16th century but found in smaller houses well into the 18th century"* [Hall, L *Period House Fixtures & Fittings* 1300-1900 Ch 6. p161] Large inglenook fireplace with large chamfered bressemer beam with corner stops. Ceiling towards the Bar end is C20 plasterboard; X1 central timber beam with timber [chipboard] hatch to FF. [Put in as a fire escape?]

Photos of Significant details

Chamfer and Ogee Stop [Chimney breast]



Chamfers to floor Joists



Chamfers and stops



Fireplace Bressumer Beam chamfer and stop



Large Inglenook with large chamfered bressumer beam



Niches and Seats in Inglenook LH side



Niches and Seats in Inglenook RH side

Far end of **ROOM D** former [painted] timber Bar with access in floor to Cellar below. Behind the Bar the gable end wall is covered with painted timber tongue and groove panelling and is probably concealing another fireplace. Entrance door to Toilet Block E.



Former [painted] timber Bar with access in floor to Cellar below

Significance Levels GROUND FLOOR

LEVEL	Elements/ Fabric	REASON
HIGH	<ul style="list-style-type: none"> • Structural External Walls/ Chimney Breasts • Inglenook Fireplace & Niches Room C • Inglenook Fireplace & Niches Room D • Chamfered Ceiling Beams & Joists Room D 	GD II Listed Building Historical & Architectural Phasing Historical & Architectural Phasing Historical & Architectural Phasing
MEDIUM		
NEUTRAL	<ul style="list-style-type: none"> • Timber Bar Counter 	Community?
LOW	<ul style="list-style-type: none"> • C20 internal doors • C20 Solid Floors • C20 Gypsum Plaster • Cement pointing on Fireplaces • Interior of Toilet Block 	No Architectural Merit Not traditional materials Not traditional materials Not traditional materials No Architectural Merit

5.2.3 FIRST FLOOR

Annotated Surveyors Floor Plan; Rooms Labelled for reference; do not scale off this drawing

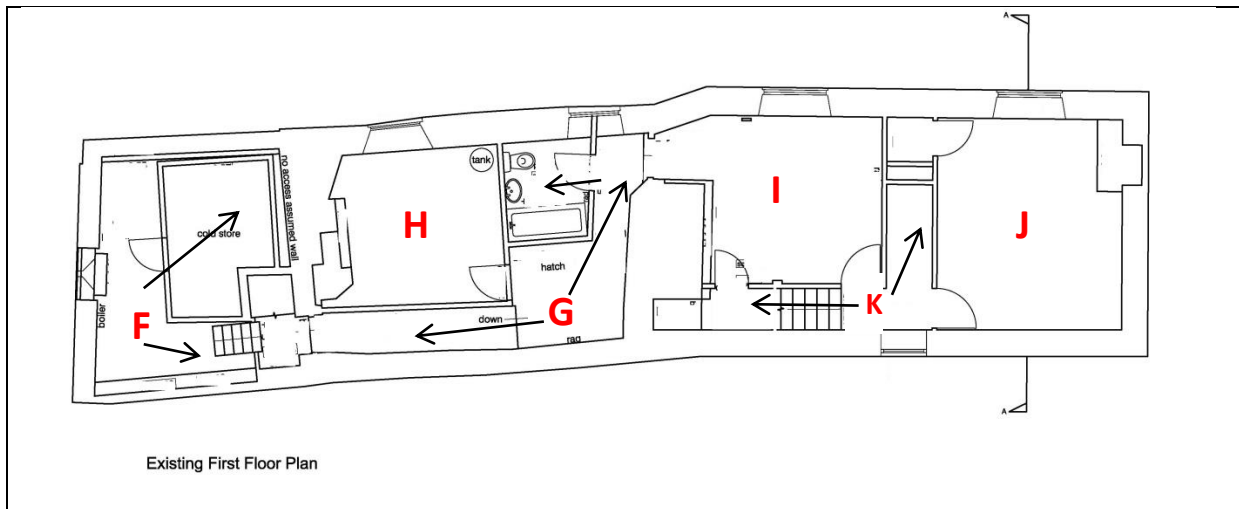

Description FF- Starting from Room F Significant observation details First floor {F G H I J K}

C20 stairs lead to **Room F**; the first floor of the two storey semi basement east end gable. This room most recently used as a Cold Store, is mostly in the Roof Void . Roof structure not visible. Much historic fabric covered with C20 wall coverings and partitions of the Cold Store. Floor level probably raised, evidence of pine C19 floorboards. Gable end wall exposed stone with lancet ventilation window covered by inserted fixed glazed window with painted timber door, probably C19 early C20. Below this is the C18/C19 loft door. Timber lintel. Rear of door not visible as boarded.



Gable end wall, lancet, fixed glazed window Scale 50cm



Timber lintel of Loft door .



Rear of C18/ C19 loft door.

Room H and G are the upper floor of the Cottage.

Room H is divided by a C20 partition wall with borrowed light via top lights creating an internal corridor. Room entered by a C19 door. Deep window recess in Eaves; possibly window of C19 origins. The ceiling has a central chamfered beam with ogee stop typical of late C17 ending at the Bathroom partition wall of vertical timbers that may need further analysis. This ceiling beam must either attach into a tie beam or be supported by a post. [This is concealed]. Ceiling; lath & plaster; C19 floorboards. External walls are probably original plaster, papered. Corbelled chimney stack covered in painted wallpaper at gable end that may have had a fireplace that could be concealed.



View of Room H from door entrance



Central chamfered beam with ogee stop

The landing area at **G** is divided to provide the C20 Bathroom. Landing; floor covered C20 Lino. Ceiling exposed timbers; another short central beam and ceiling joists. Walls paper, probably hiding original plaster; exposed ends of a possible raised cruck in both outer walls on the Landing **G** and visible in the external wall in the Bathroom. Landing has hatch to roof with access to roof over **H** and **G**.



G central beam and joists.



G possible raised cruck [Landing][See Roof Void]

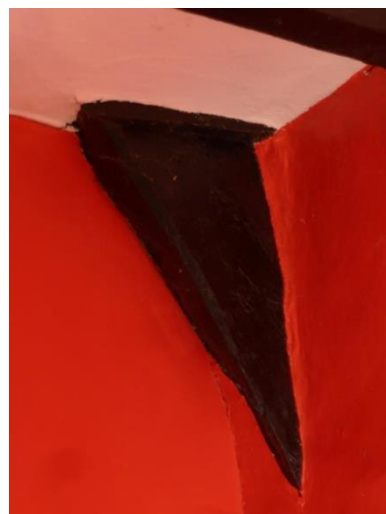

G possible raised cruck [Bathroom] [See Roof Void]

Significant observation details

Crucks in Traditional Buildings

Cruck Construction in traditional buildings have been used from Medieval time to the late 18th Century and types of Cruck construction based on the cruck idea remained in use especially for farm buildings until well into the 19th century. The enclosing walls could be any material and “ *an apparently solid gritstone wall may conceal a timber frame wall itself cladding a set of cruck trusses*” [B Brunskill, Houses & Cottages of Britain, p172]

Upper Crucks and Raised Crucks

Upper Crucks do not run to ground level but terminate in a horizontal beam that is carried by some type of mass wall. The Upper Cruck is tenoned into the floor beam. The curved feet of the inclined members acknowledge the Cruck tradition but the structure was essentially that of the independent roof truss. However a raised Cruck rises from part way up a solid wall [B Brunskill, Houses & Cottages of Britain Diagram pg 175]

ROOF OVER H and G – Roof void of Cottage North Arms

There is X1 Cruck truss within the roof area that is of standing room height over **H** and **G** and although this cannot be answered definitely from this assessment it would appear this is a possible raised Cruck as they are seen below the ceiling beams. [See page 43] The roof area is boarded and some roof timbers and gable end walls have some evidence of limewash that would indicate that the void may have been plastered and used as sleeping accommodation. Certainly a garret in old buildings can be provided by providing extra headroom by using Upper Crucks .

Significant observation details



Cruck truss within the Roof area over H and G



Boarded and evidence of limewash
View to West



Evidence of limewash
View to East and a brick Chimney stack

ROOM I

Beside the end gable chimney stack of the main building a passage leads to **ROOM I**. This may have been knocked through from the Cottage to the Main Building at some stage. There are wide Oak/Elm floorboards in this area laid vertically. **Room I** has a large chimney stack that probably conceals a fireplace. Ceiling lath and plaster with some boxed in ceiling beams. Floor; Oak boards fairly wide running horizontally from front to back. X1 window to south with early C19 mullion and transoms. By the chimney stack is a cupboard with a good example of a X4 plank ledge door with wooden latch and pull handle probably dating from the end of C17 or C18. These are hard to date and many survive from the C17 and early C18 and are mostly internal doors. The main internal door of **Room I** is also a rare survivor. This is a door with an applied panelling with moulded fillet usually dating from last quarter of the C17, There is an exact door illustrated in Linda Halls *Period House Fixtures and Fittings 1300-1900* dated 1743 in Westmorland CH 2. pg 38. The door has some original ironmongery [painted] [Hall ,L Period House Fixtures & Fittings 1300-1900]

Significant observation photos of details



Passage leads to **ROOM I** 1 metre Scale



ROOM I Large chimney stack

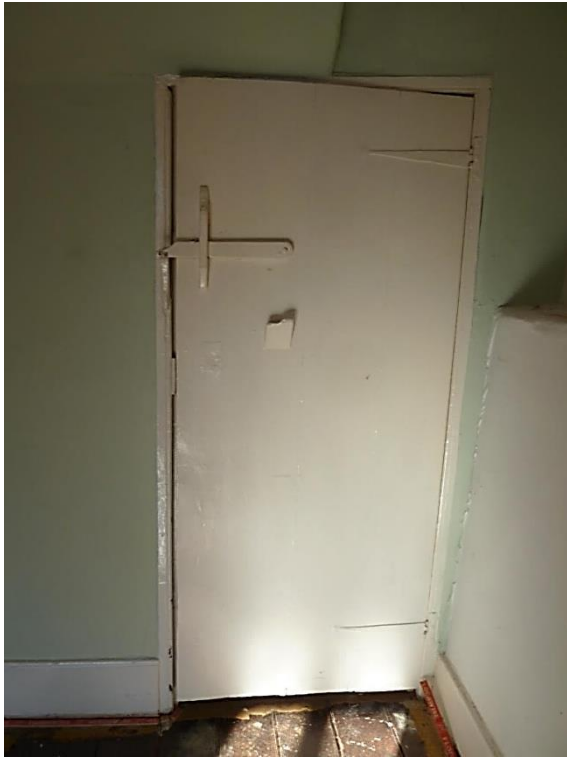

ROOM I C17 door with wooden latch and pull handle



ROOM I C17 door with an applied panelling with moulded fillet

ROOM J

Room J is situated in the west gable end separated by area K by a stud wall of lath & plaster. Floorboards are narrower, indicating probably C19. To gable end wall exposed fireplace opening inserted in stone wall with a stone lintel and hearth. Window to south is another C19 Mullion & Transom. C20 door to cupboard, C20 door to landing area.



Fireplace opening inserted in stone wall



C19 Mullion & Transom Window

ROOM K

Landing area and space [Possibly the site of a former staircase to ground floor] between **ROOM I & J**; lath & plaster walls, end wall lit by a small window; opposite another window to north overlooking Mills Lane. Chipboard flooring with hatch in floor to PH Bar below. This area K leads to the upper floor via a staircase:-

Significance Levels FIRSTFLOOR

LEVEL	Elements/ Fabric	REASON
HIGH	<ul style="list-style-type: none"> • Structural External Walls/ Chimney Breasts • Loft Door/Frame and lintel Room F • Chamfered Ceiling Beam Room H • Exposed Raised Crucks in Walls Landing Area G and Bathroom • Original plaster Landing G • Roof Timbers over H & G x1 Cruck Truss • Wide Floor boards Room I • C17 Door & Latch Room I • C17 Door with panel Room I • Early C19 Windows Rooms I & J • Fireplace Room J 	GD II Listed Building Historical & Architectural Phasing Historical & Architectural Phasing Historical & Architectural Phasing Historical & Architectural Phasing Historical & Architectural Phasing Historical & Architectural Phasing Historical & Architectural Phasing Historical & Architectural Phasing Historical & Architectural Phasing
MEDIUM	<ul style="list-style-type: none"> • C19 Fixed window & Door Room F • Window Room H • C19 Flooring Room J • Flooring Roof Void H & G Poor Condition 	Historical & Architectural Phasing Historical & Architectural Phasing Historical & Architectural Phasing Historical & Architectural Phasing
NEUTRAL	<ul style="list-style-type: none"> • Partition Wall Room H & Bathroom • Flooring Roof Void H & G • Floor Room F 	Further Analysis Further Analysis Further Analysis
LOW	<ul style="list-style-type: none"> • C20 internal doors • C20 Partitioning • C20 Gypsum Plaster • Cement pointing on Fireplace Room J • Chipboard Flooring 	No Architectural Merit Not traditional materials Not traditional materials Not traditional materials Not traditional materials

5.2.4 SECOND FLOOR

Annotated Surveyors Floor Plan Rooms Labelled for reference; do not scale off this drawing

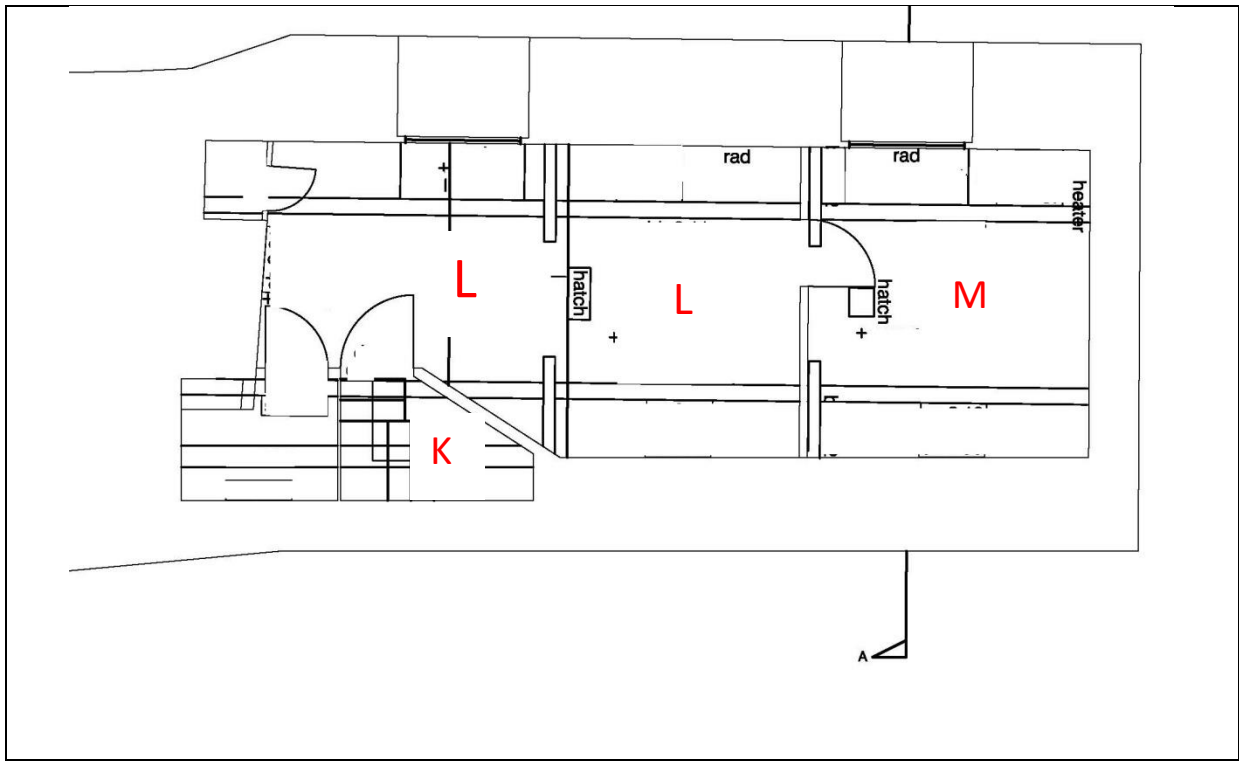

Description SF- Starting from K Staircase Significant observation details Second floor {K L M}

The Second floor over the main building extends over **Rooms I & J** below. This attic Room/s is approached by a **staircase K** in the north elevation wall. The ceiling of the **stairs K** is within the eaves. Roof timbers exposed with limewashed ceiling and wide timber boarding to some walls. Stairs straight with a winder turn appear to be oak, probably C18 or early C19. At the top of the stairs is a painted door x3 wide planks with C18 strap hinges and latch. Cut into this door is a semi-circular portal/peephole with unusual unpainted circular timber sliding surround. This upper **Room L** is divided at one end, west, by a painted timber tongue & groove boarded wall with C20 door to **Room M**. The east end **Room L** has two cupboards either side of the chimney breast. A X4 plank door; C18 with strap hinges and catch beside the main door has access to the eaves. The RH door cupboard beside chimney breast is a x2 plank door with strap hinges and latch. There is a hatch in the ceiling. Both Rooms lath & plaster walls and ceiling, with unpainted cruck blades visible; wide floorboards although many replacements. There is also a small hatch in the ceiling of **Room M**. In the side North wall in **Room M** is a low access door to view eaves. **Room M** also has wide floorboards in better condition. *'Original floorboards get narrower over time, early floorboards can be over a foot wide and are often elm rather than oak'* [Hall ,L Period House Fixtures & Fittings 1300-1900 pg 165]

Photos Significant observation details second floor



Attic Room/s are approached by a **staircase K** in the North elevation wall



Roof timbers on stairs exposed and limewashed ceiling and wide timber boarding.



Roof timbers on stairs exposed and limewashed ceiling and wide timber boarding.



View East **Room L** . Cruck Truss
The Second floor over the main building extends over **Rooms I & J** below.



View West **Room L** Cruck Truss
The Second floor over the main building extends over **Rooms I & J** below. Dividing Wall to Room M



C17-C18 X2 Doors. Main Door and Cupboard



Portal/peephole in Main door with unusual unpainted circular timber sliding surround. 50cm scale



Example of C17-C18 Strap Hinge



Cupboard to Eaves LH of Chimney



LH of Chimney Breast x2 C18 plank door with strap hinges and latch.



Wide Original floorboards 1m Scale **Room M**



In the side North wall in **Room M** is a low access door to view eaves. View East with Cruck



In the side North wall in **Room M** is a low access door to view eaves. View West

SECOND FLOOR roof Over Rooms L & M

With limited inspection by looking into the roof via both X2 ceiling inspection hatches it was possible to make out two cruck trusses pegged at the apex. Chamfered ; adze marks and evidence of collar ties, no longer in place.

DATING - The Crucks in both this roof void and the Cottage could be dated by dendrology methods that might give a more accurate date for the building/s



Cruck Blades seen from inspection hatch in **Room M**

Significance Levels SECOND FLOOR

LEVEL	Elements/ Fabric	REASON
HIGH	<ul style="list-style-type: none"> • Structural External Walls/ Chimney Breasts • Oak/Elm Staircase • Exposed limewash/plaster stairwell • Door with peephole • Doors to recessed cupboards • Wide floorboards • Cruck Blades 	GD II Listed Building Historical & Architectural Phasing Historical & Architectural Phasing Historical & Architectural Phasing Historical & Architectural Phasing Historical & Architectural Phasing Historical & Architectural Phasing
MEDIUM	<ul style="list-style-type: none"> • C19 Walls to Eaves later additions 	Historical & Architectural Phasing
NEUTRAL	<ul style="list-style-type: none"> • Partition wall dividing Room L with M • Dormer windows 	No Architectural Merit No Architectural Merit/Analysis
LOW	<ul style="list-style-type: none"> • C20 door in partition wall • Staircase handrail • Copper heating pipes • Plaster board to ceiling 	No Architectural Merit No Architectural Merit Detracts Not traditional materials

5.3 Exterior Stable Building

Photo of Elevations



Nesting Hole Detail

Front Elevation facing Yard



Side Gable Facing North



Side Gable Facing South

Description

C18 Two storeys built with coursed squared ironstone under corrugated iron roof ; central carriage door opening ; concrete lintel; C20 doors with loft timber door above hung on spear hinges [probably early C19] . Mid way string course with a row of x6 nesting inserts with stone sills. Ground floor LH C19 casement window with timber lintel; evidence of similar size window to Ground floor RH now filled in with stone. To south side attached are x2 single storey stone outbuildings and enclosed walling.



To south side of Stable are x2 a single storey stone outbuildings

Significance Levels

LEVEL	Elements/ Fabric	REASON
HIGH	<ul style="list-style-type: none"> • Structural External Walls • Timber lintels above windows • C19 loft door & hinges • X6 Nesting boxes 	GD II Listed Building Historical & Architectural Phasing Historical & Architectural Phasing Historical & Architectural Phasing
MEDIUM	<ul style="list-style-type: none"> • corrugated iron roof • C19 Casement window 	Historical & Architectural Phasing Historical & Architectural Phasing
NEUTRAL		
LOW	<ul style="list-style-type: none"> • C20 Central doors • Concrete lintel to main opening • Doors to single storey outbuildings • C20 External light fittings on Exterior • Tarmac to Yard area 	No Architectural Merit Not traditional materials No Architectural Merit Detracts Detracts

5.4 Interior: note of significant features Stable Building

Photos



Evidence of former floor for second storey/ corrugated roof

Evidence of former floor for second storey with some beams remaining but propped. Historic Roof structure no longer in situ and replaced along with a corrugated roof over. No loose boxes or stable fixtures and fittings remain. Some floor is historic and laid to bricks, most is concrete with a C20 inspection pit for cars?. This pit is lined with breeze blocks and not further inspected as it was full of rubbish.



Some floor is historic laid to bricks



C19 Casement window internal view

Significance Levels

LEVEL	Elements/ Fabric	REASON
HIGH	<ul style="list-style-type: none"> • Structural Internal Walls/ nesting boxes 	GD II Listed Building
MEDIUM	<ul style="list-style-type: none"> • Brick floor /poor condition • Evidence of former floor beams/level 	Historical & Architectural Phasing Historical & Architectural Phasing
NEUTRAL		
LOW	<ul style="list-style-type: none"> • Concrete floor 	Not traditional materials

6 Summary Assessment of Significance North Arms and Stable

6.1 Background to Assessments of Significance

Significance: The value of a heritage asset to this and future generations because of its heritage interest. That interest may be archaeological, architectural, artistic or historic.

Definition of Significance

Significance (for heritage policy)

The value of a heritage asset to this and future generations because of its heritage interest. The interest may be archaeological, architectural, artistic or historic. Significance derives not only from a heritage asset's physical presence, but also from its setting. For World Heritage Sites, the cultural value described within each site's Statement of Outstanding Universal Value forms part of its significance. Annex 2 Glossary <https://www.gov.uk/guidance/national-planning-policy-framework/annex-2-glossary>

2) "The sum of the cultural and natural heritage values of a place, often set out in a statement of significance." p72 [Conservation Principles](#), English Heritage, 2008

<https://historicengland.org.uk/advice/hpg/hpr-definitions/#s>

In order to identify the significance of a place, it is necessary first to understand its fabric, and how and why it has changed over time; and then to consider: who values the place, and why they do so; how those values relate to its fabric; their relative importance; whether associated objects contribute to them; the contribution made by the setting and context of the place; how the place compares with others sharing similar values. [Ref Conservation Principles English Heritage/Historic England p21]

'The English Heritage [now Historic England] Guidance Conservation Principles 2008 on assessing significance sets out the following four areas for consideration:

- **Evidential value:** *the potential of a place to yield evidence about past human activity. Evidential value derives from the physical remains or genetic lines that have been inherited from the past. The ability to understand and interpret the evidence tends to be diminished in proportion to the extent of its removal or replacement.*
- **Historical value:** *the ways in which past people, events and aspects of life can be connected through a place to the present – it tends to be illustrative or associative. The way in which an individual built or furnished their house, or made a garden, often provides insight into their personality, or demonstrates their political or cultural affiliations. It can suggest aspects of their character and motivation that extend, or even contradict, what they or others wrote, or are recorded as having said, at the time, and so also provide evidential value. Historical values are harmed only to the extent that adaptation has obliterated or concealed them, although completeness does tend to strengthen illustrative value.*

• **Aesthetic value:** *the ways in which people draw sensory and intellectual stimulation from a place. Design value relates primarily to the aesthetic qualities generated by the conscious design of a building, structure or landscape as a whole. It embraces composition (form, proportions, massing, silhouette, views and vistas, circulation) and usually materials or planting, decoration or detailing, and craftsmanship. It may be attributed to a known patron, architect, designer, gardener or craftsman (and so have associational value), or be a mature product of a vernacular tradition of building or land management.....Some aesthetic values are not substantially the product of formal design, but develop more or less fortuitously over time, as the result of a succession of responses within a particular cultural framework. They include, for example, the seemingly organic form of an urban or rural landscape; the relationship of vernacular buildings and structures and their materials to their setting; or a harmonious, expressive or dramatic quality in the juxtaposition of vernacular or industrial buildings and spaces.*

• **Communal value:** *the meanings of a place for the people who relate to it, or for whom it figures in their collective experience or memoryCommunal values are closely bound up with historical (particularly associative) and aesthetic values, but tend to have additional and specific aspects.*

[Conservation Principles English Heritage 2008]

<https://historicengland.org.uk/images-books/publications/conservation-principles-sustainable-management-historic-environment/>

Summary of Significance of the North Arms gained from this Report

NB

The four principle Significance Values for The North Arms have only been based on the scope and limitations of this report and further evidential and historical evidence of value may yet to be found.

6.1.2 Evidential Value/Architectural Value

The evidential value lies primarily in the architecture of the main house and its outbuilding that date from the 17th, 18th, centuries. The North Arms and Stable Outbuilding are recognised as nationally designated heritage assets graded Grade II. Both are good examples of the vernacular style of architecture in Wroxton and this region of Oxfordshire.

The overall plan forms of the main building/s have changed little. The main structure still has raised crucks within the two principle roof structures. Alterations to internal layout with some partitioning and removal of ground floor staircases have occurred. Additions have been made in the 19th century to the frontages probably when the dwelling became a Public House but are still of architectural value. There is some evidence that this was once two dwellings, each has substantial chimney breasts and stacks with inglenook fireplaces serving ground floor rooms. Internally there are some original fixtures and fittings; 18th internal doors; wide floorboards; an upper staircase.

6.1.3 Historical Value-

Historical value lies from the architectural phasing, 17th 18th and 19th centuries and this is largely of illustrative value as probably a once working tenant dwelling house/s but mostly as a Public House and dwelling house in the 19th centuries through to the present day. There is evidence in the newspaper archives from the 19th century that there was a stable and smallholding as well as a brewhouse. Of historical associative value there is the historical association with Wroxton Abbey and the North family. Indeed the Public House is named after the family. Frederick North was Prime Minister from 1770-1782 and spent much of his youth at Wroxton Abbey, his son George, Lord North took over the constituency of Banbury and was said to frequent the North Arms Public House. He was also the Oddfellows Society president who met in the North Arms throughout the 19th century and early 20th century. There is the 19th century historical association with William Kalabergo the last person to be hanged publically in Oxford and who was incarcerated in North Arms. He escaped from an attic room by sliding down the roof but was quickly caught by Mr Harris the then landlord.

6.1.4 Aesthetic /Setting/Group Value

Aesthetic/setting value at the North Arms lies from the surrounding Village and its buildings as well as the North Arms building itself. The conservation area boundary includes the Historic Park and Garden of Wroxton Abbey, itself designated GDI. [Present country house, now home to the Fairleigh Dickinson University, dates from c.1618 was built on the site of an Augustinian Priory founded in 1217] The buildings in the village are primarily of a simple local vernacular, constructed in coursed rubble ironstone with steep roof pitches overlaid with thatch, or in a smaller number with slate or tiles.

6.1.5 Community Value

Community value lies within the collective experience or memory of the past owners/tenants and visitors to the Public House. The Public House when closed was made an Asset of Community Value in 2016.

6.2 Statement of Significance

This is a short statement of significance based on the desk based historical research without a visit to the main archives and an in depth map regression exercise. This statement is based on this research and on observations carried out by RDA qualified staff on a site visit to record at a Level 1-2 building recording.

The North Arms and separately listed Stable Outbuilding are important architecturally and historically, with its associations with the North family of Wroxton Abbey. The North Arms is a prominent building in the Village and makes an important contribution to its setting. The Public house has original features from at least the 18th century, including x3 possible raised cruck trusses. Further analysis could be carried out for dating the timbers by using dendrology methods. There is evidential phasing from the 18th and 19th century, with additions made in the 20th century in the form of external doors, windows and the alterations to the now Toilet Block. The North Arms has some surviving significant features of note from the 17th century up to the 19th century all helping to tell a story of the buildings past. There has been inevitable loss of historic external windows and doors, and many external openings have changed over time especially during the 19th century.

Bibliography

Primary Source

The North Arms Heritage Report from Wroxton Librarian
 Email correspondence NW Alcock [raised crucks]
 Email Correspondence Maureen Woollacott

Secondary Source

Alcock, Barley, Meeson Recording Timber-Framed Buildings Illustrated Glossary: CBA Handbook

Brunskill, R 1997 Houses & Cottages of Britain Origins & Development of Traditional Buildings; Victor Gollanz.

Brunskill, R., 1981. Traditional Buildings of Britain. In: s.l.:Victor Gollanz.

Brunskill, R., 1985 Timber Building in Britain. In: s.l.:s.n.

Brunskill,R 1970. Illustrated Handbook of Vernacular Architecture. In: s.l.:Faber.

Hall ,L 2005-2015 Period House Fixtures & Fittings 1300-1900 Newbury: countryside books

Hall,L & NW Alcock Fixtures and Fittings in Dated Houses 1567-1763 Practical Handbook: CBA

Historic England A Guide to Good Recording Practice (Historic England, 2016)

Historic England Strategic Stone Study A Building Stone Atlas of Oxfordshire December 2017

Harris, R., 1978. Discovering Timber -Framed Buildings. In: s.l.:Shire Publication Ltd

Peters J.E.C 1981 Discovering Traditional Farm Buildings In: s.l.:Shire Publication Ltd.

Secull, D "Wroxton The Village and its people in Photographs."1993 printed by Banbury Litho Ltd.
 Oxford Road Adderbury

Websites

Conservation Principles English Heritage 2008

<https://historicensland.org.uk/images-books/publications/conservation-principles-sustainable-management-historic-environment/>

Conservation area appraisals – Wroxton August 2017

<https://www.cherwell.gov.uk/directory-record/1839/wroxton>

Guidance on applications relating to heritage assets Cherwell District Council PDF

<https://www.cherwell.gov.uk/directory/89/useful-conservation-and-heritage-links>

Heritage Assessment of The North Arms, Mills Ln, Wroxton, Banbury OX15 6PY

<https://www.oxfordshire.gov.uk/residents/environment-and-planning/archaeology/historic-environment-record>

<https://www.publicaccess.cherwell.gov.uk/online-applications/searchResultsBack.do?action=back>

<https://britishlistedbuildings.co.uk/101185033-the-north-arms-public-house-wroxton>

<https://britishlistedbuildings.co.uk/101046788-outbuilding-approximately-5-metres-east-of-the-north-arms-public-house-wroxton#.XFDCmBKnxxA>

<https://britishlistedbuildings.co.uk/england/wroxton-cherwell-oxfordshire#.XFDBDxKnxxB>

<http://www.wroxton.org.uk/old%20pictures.htm>

Strategic Stone Study A Building Stone Atlas of Oxfordshire First published by English Heritage March 2011 Rebranded by Historic England December 2017

<https://www.banburyguardian.co.uk/news/future-in-doubt-for-historic-inn-1-5006709>

<https://www.british-history.ac.uk/vch/oxon/vol9/pp171-188>

'Parishes: Wroxton', in *A History of the County of Oxford: Volume 9, Bloxham Hundred*, ed. Mary D Lobel and Alan Crossley (London, 1969), pp. 171-188. *British History Online* <http://www.british-history.ac.uk/vch/oxon/vol9/pp171-188> [accessed 18 February 2019].

Appendix Surveyors Plans

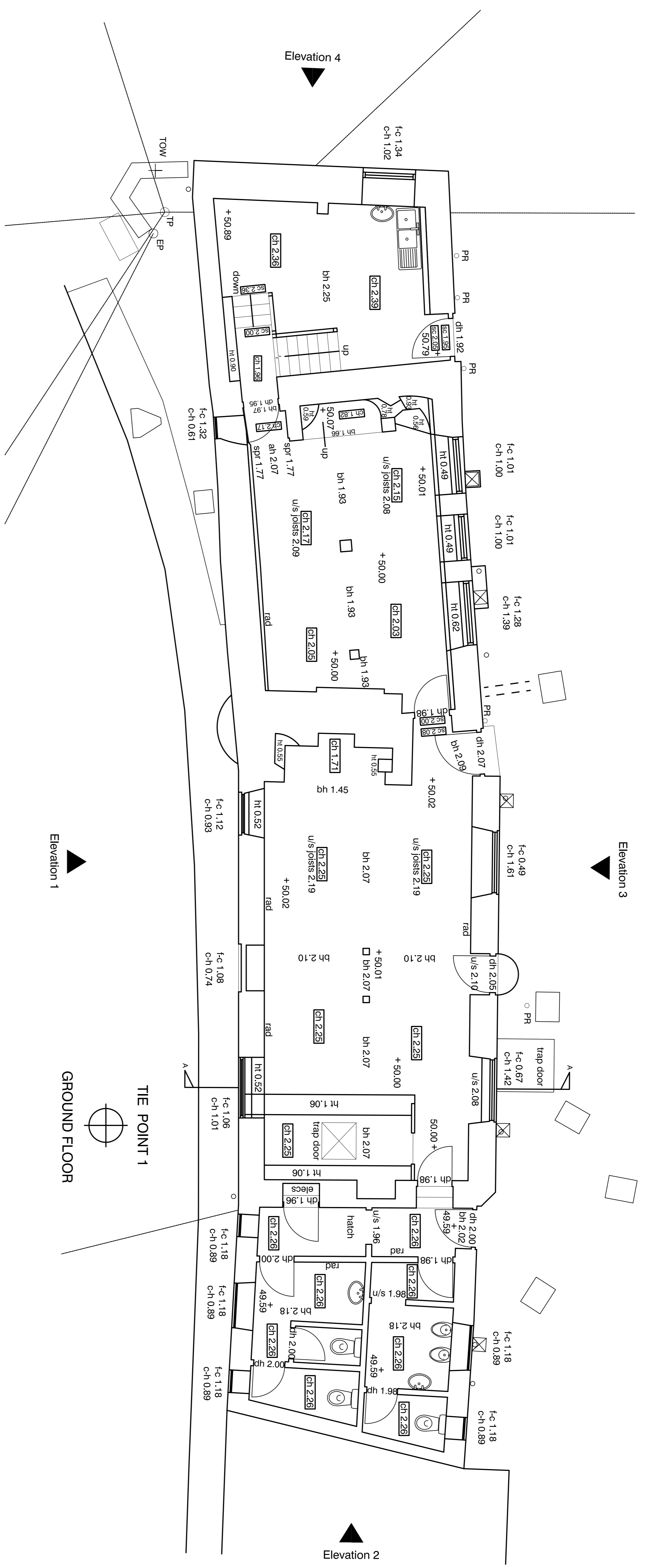

Existing Ground floor plan

Existing Cellar Plan

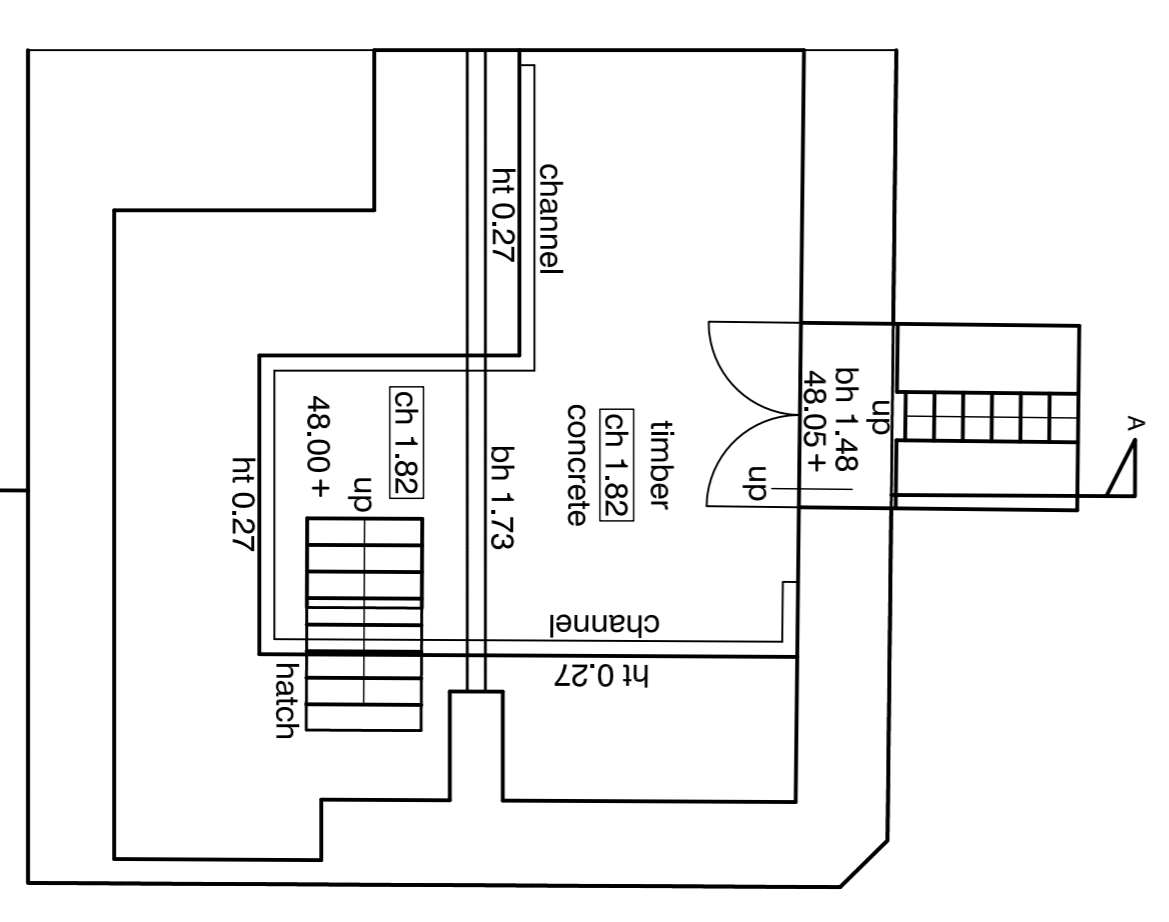

TIE POINT 1

Drawn By	SS	Scale	1:50 at A1
Checked		Date	May 2016

Drawing
Survey as Existing
Basement and Ground Floor Plans

Project
North Arms
Wixton

Client
Wixton College

Brear Associates

The Beer House
Atherstone Hill
Atherstone on Stour
Stratford on Avon
CV37 8NF
Tel:01789 450283

Drawing No
2016-34/01

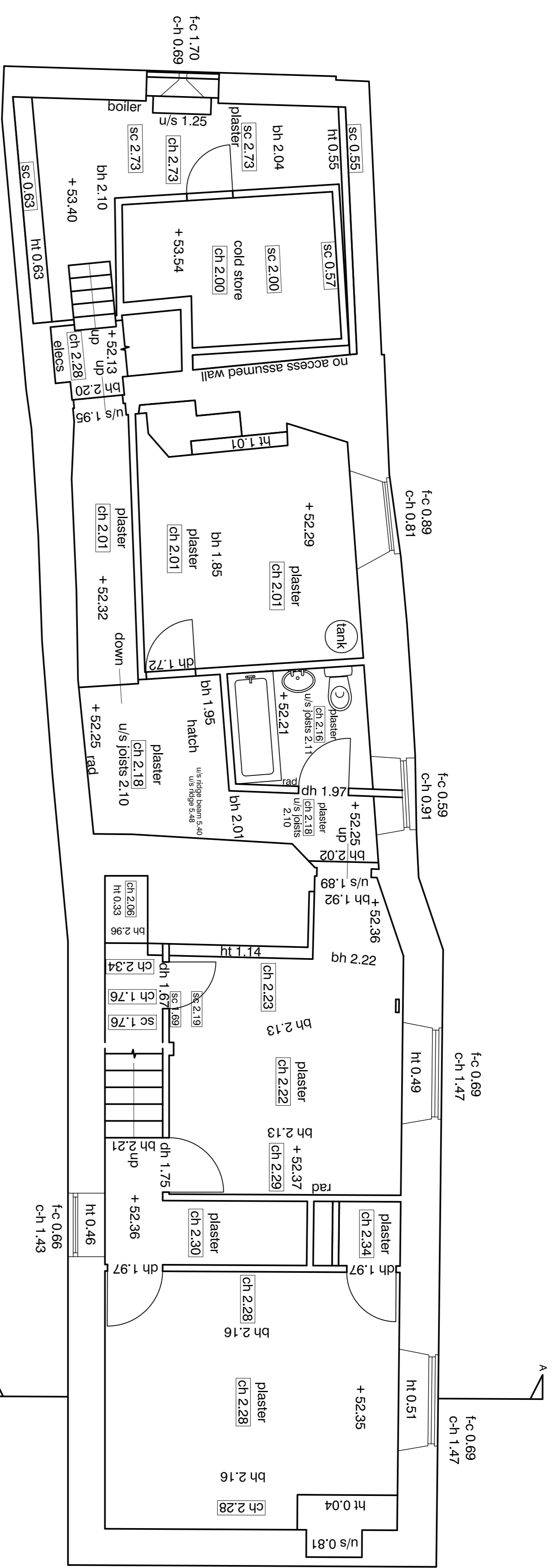

Existing First Floor Plan

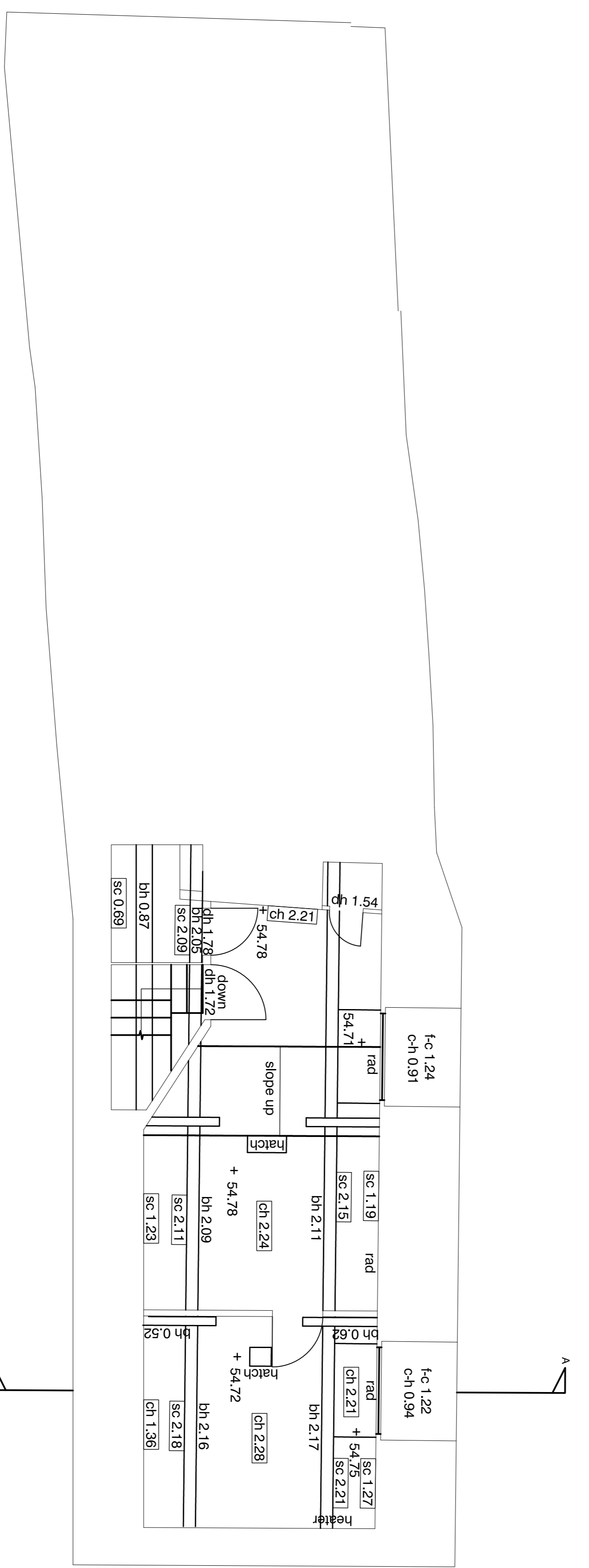

Existing second floor plan

Drawn By	SS	Scale	1:50 at A1
Checked		Date	May 2016
Drawing			
Survey as Existing First floor and Second Floor Plans			
Project			
North Arms Wixton			
Client			
Wixton College			
Brear Associates			
The Beer House Atherstone Hill Atherstone on Stour Stratford on Avon CV37 8NF Tel:01789 450283			
Drawing No			
2016-34/02			

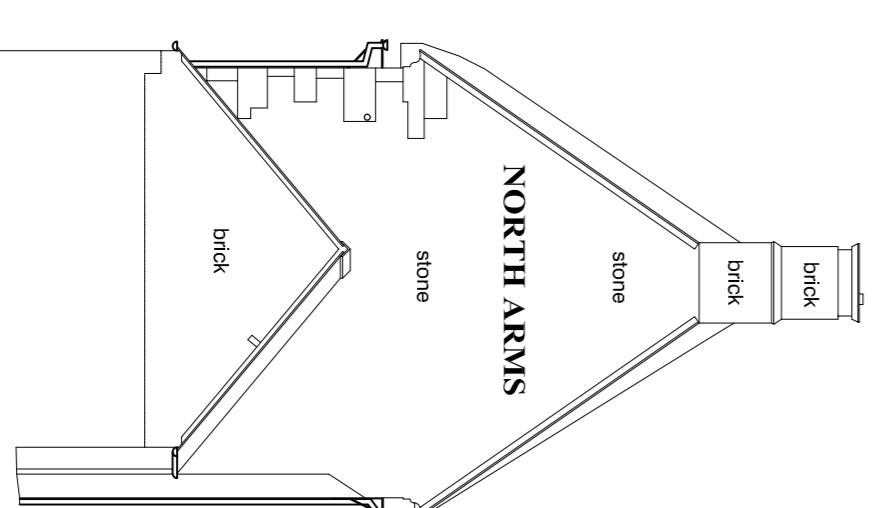
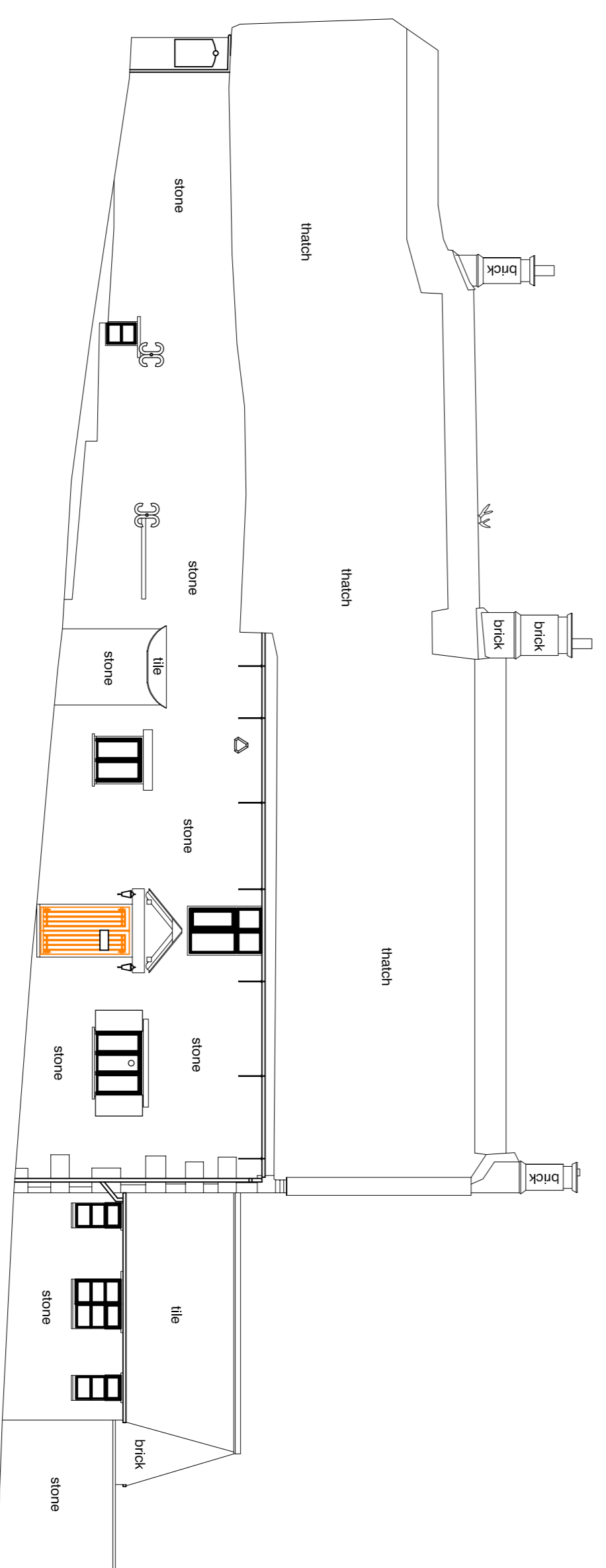
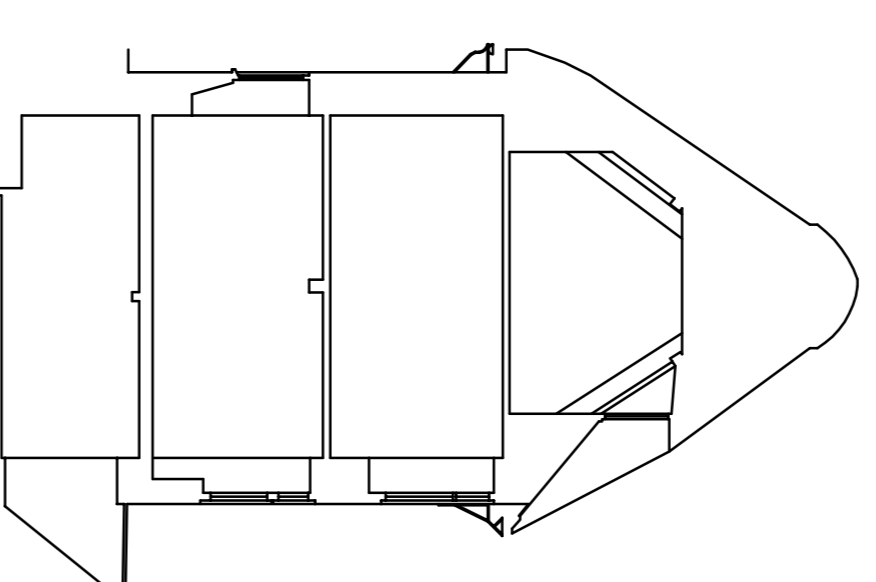
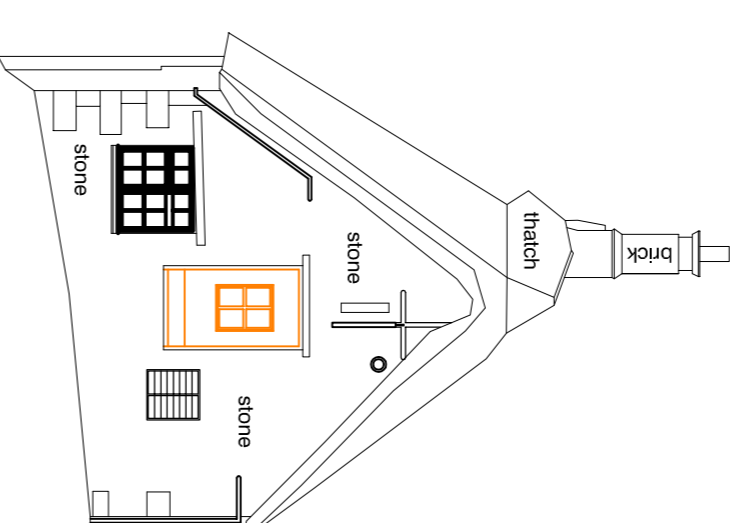
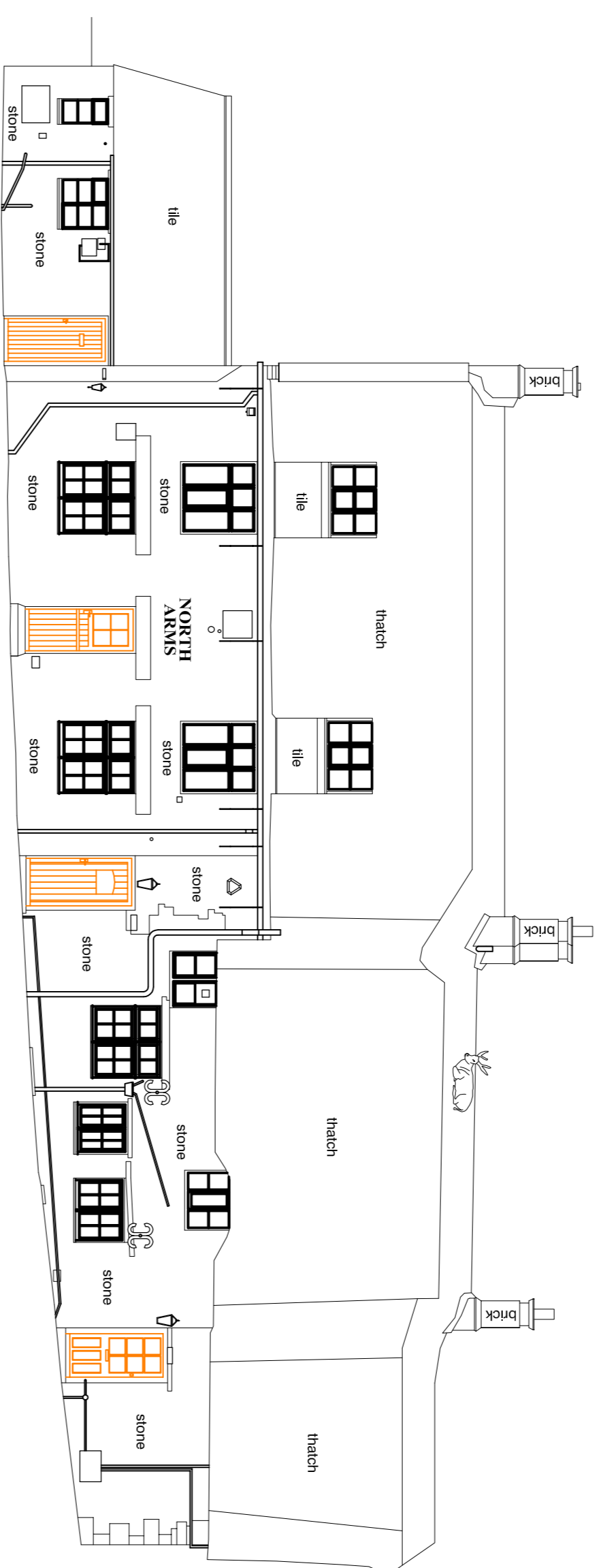

Drawn By	SB	Scale	1:100 at A1
Checked		Date	May 2016

Drawing
Survey as Existing
Elevations

Project
North Arms
Wroxton

Client
Wroxton College

Brear Associates

The Beer House
Atherstone Hill
Atherstone on Stour
Stratford on Avon
CV37 8NF
Tel:01789 450283

Drawing No

2016-34/03