



**GENERAL NOTES:**

- DO NOT SCALE THIS DRAWING.
- THIS DRAWING IS TO BE READ IN CONJUNCTION WITH ALL OTHER RELEVANT ENGINEERS, ARCHITECTS AND SPECIALIST DESIGN DRAWINGS AND DETAILS.
- ALL DIMENSIONS ARE IN METRES UNLESS NOTED OTHERWISE. ALL LEVELS ARE IN METRES UNLESS NOTED OTHERWISE.
- ANY DISCREPANCIES NOTED ON SITE ARE TO BE REPORTED TO THE ENGINEER IMMEDIATELY.
- THE CONTRACTOR SHALL CHECK ALL TIE-INS FOR LINE AND LEVEL WITH EXISTING BEFORE COMMENCING ANY WORKS. THE ENGINEER SHALL BE NOTIFIED IMMEDIATELY IN WRITING, SHOULD ANY ERRORS BE FOUND.
- IT IS THE RESPONSIBILITY OF THE CONTRACTOR TO LOCATE ANY SERVICE APPARATUS IN THE VICINITY OF THE WORKS. THE CLIENT WILL ACCEPT NO CLAIMS WHATSOEVER IN RESPECT OF ANY LOSSES OR DAMAGE CAUSED IN RESPECT OF SUCH APPARATUS, HOWEVER CAUSED.
- IT IS THE RESPONSIBILITY OF THE CONTRACTOR TO EXECUTE THE WORKS AT ALL TIMES IN STRICT ACCORDANCE WITH THE REQUIREMENTS OF THE HEALTH AND SAFETY AT WORK ACT 1974, AND THE C.D.M. REGULATIONS 2015. THE CONTRACTOR WILL BE DEEMED TO HAVE ALLOWED FOR FULL COMPLIANCE, INCLUDING FULL LIAISON WITH THE PLANNING SUPERVISOR, WITHIN HIS RATES.
- THE CONTRACTOR IS RESPONSIBLE FOR ENSURING THAT ALL WORKS ARE TO THE SATISFACTION OF THE ENGINEER, AND SHALL BE DEEMED TO HAVE INCLUDED WITHIN HIS RATES FOR ANY NECESSARY TESTING.
- THE CONTRACTOR WILL BE RESPONSIBLE FOR PROVIDING ALL NECESSARY DE-WATERING AND TRENCH SUPPORT TO EXECUTE THE WORKS IN A SATISFACTORY MANNER, AND SHALL BE DEEMED TO HAVE ALLOWED FOR THE SAME WITHIN HIS RATES.
- ALL BURIED CONCRETE PRODUCTS AND MORTAR SHALL BE MADE USING SULPHATE RESISTING CEMENT.

- KEY:**
- PRIVATE DRIVE CARRIAGEWAY CONSTRUCTION
  - RUMBLE STRIP BETWEEN PRIVATE DRIVE AND MAIN CARRIAGEWAY (SEE DRG NO. 20488\_02\_080\_03)
  - TYPE EF KERB EDGING (0mm UPSTAND) (SEE DRG NO. 20488\_02\_080\_03)

THIS DRAWING IS BASED ON PLANNING LAYOUT BAN3-02-100 - (RECEIVED 11.09.18)

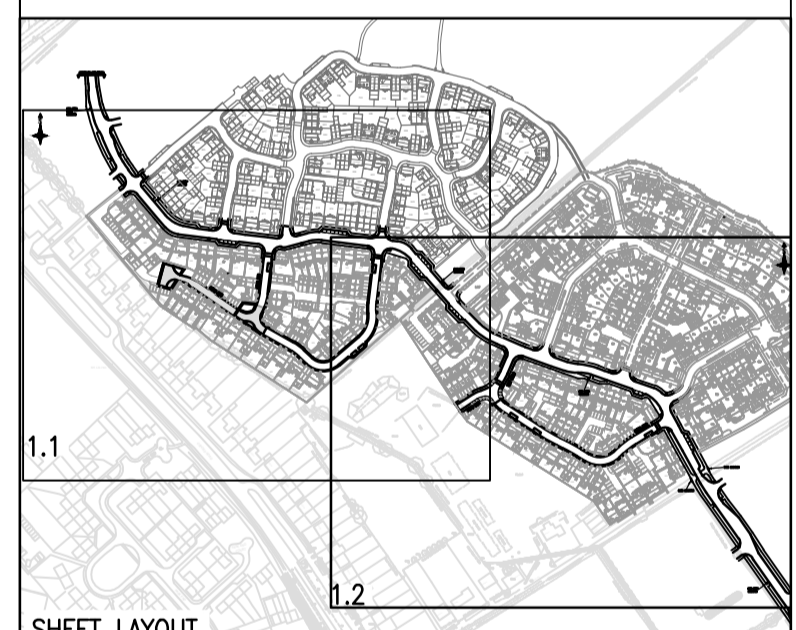

**SHEET LAYOUT**

C	PLANNING LAYOUT UPDATED	EG	CG	28.09.18
B	SERVICE STRIP ARRANGEMENT ABOUT SQUARES AMENDED	JP	KA	09.11.16
A	PLANNING LAYOUT UPDATED	VP	MA	20.10.16
REV:	AMENDMENTS	DRN	CHK	DATE:

**PROJECT:**  
**LONGFORD PARK**  
**BODICOTE**  
**BANBURY**

**DRAWING TITLE:**  
**PARCEL D & E PRIVATE KERBING AND SURFACES**  
**SHEET 2 OF 2**

**CLIENT:**  
**BARRATT HOMES, BOVIS HOMES & TAYLOR WIMPEY**

**DRAWING NUMBER:**  
**20488\_02\_060\_302.2**

<b>REVISION:</b> C	<b>SHEET SIZE:</b> A1	<b>SCALE:</b> 1:500
<b>DRAWN BY:</b> DMH	<b>CHECKED BY:</b>	<b>DATE:</b>

**STATUS:**  
**FOR INFORMATION / APPROVAL**

**M-EC** Wellington House Leicester Road  
 Ibstock Leicestershire LE17 6HP  
 T: 01530 264 753  
 F: 01530 588 116  
 lbstock@m-e-c.co.uk  
 www.m-e-c.co.uk

ORDNANCE SURVEY © CROWN COPYRIGHT 2014. ALL RIGHTS RESERVED.  
 LICENCE NUMBER 10002432.

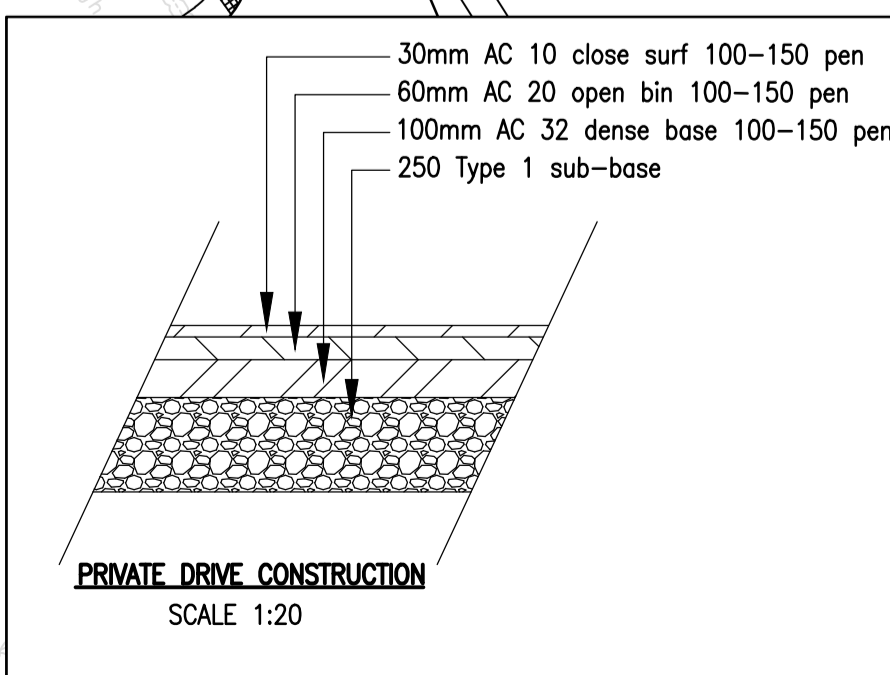

File Location: T:\M-EC Job Book\20488\Drawings\m-e-c\Parcel d & e\02 service Infrastructure\20488\_02\_060\_302.2 Private Kerbing and surfacing (CURRENT DO NOT ISSUED).dwg Printed: 28.09.2018