

## ACCESS

### BASE INSTRUCTIONS

Flat and firm base. Recommended: concrete, tarmac or paving flags.  
 Min. distance from walls/ shrubbery: 1000mm.  
 Min. base size (WxDxH) 2200mm x 1150mm x 50mm.

### LEVELING THE UNIT

Correctly level the constructed unit using the shims (ZCOMPPLAS) provided prior to fixing the unit to the ground. Slide the packing pieces under the corners of the unit base as required until an equal gap has been achieved around the door allowing for its smooth operation and alignment.

It is always recommended to anchor the unit in to the ground. Drill through the four holes in the base of the unit using 6mm dia masonry drill to a depth of 70mm. Screw in the anchor fixings. (These have a self cutting thread). If not anchoring the unit, fit the self seal plugs BEFORE BUILDING to block the fixing holes from underneath.

### TOOLS REQUIRED

Power driver POSI-DRIV screwdriver, 6mm dia. masonry drill and a 10mm socket or spanner.



Warning: some panels may weigh over 20Kg. Beware of manual handling

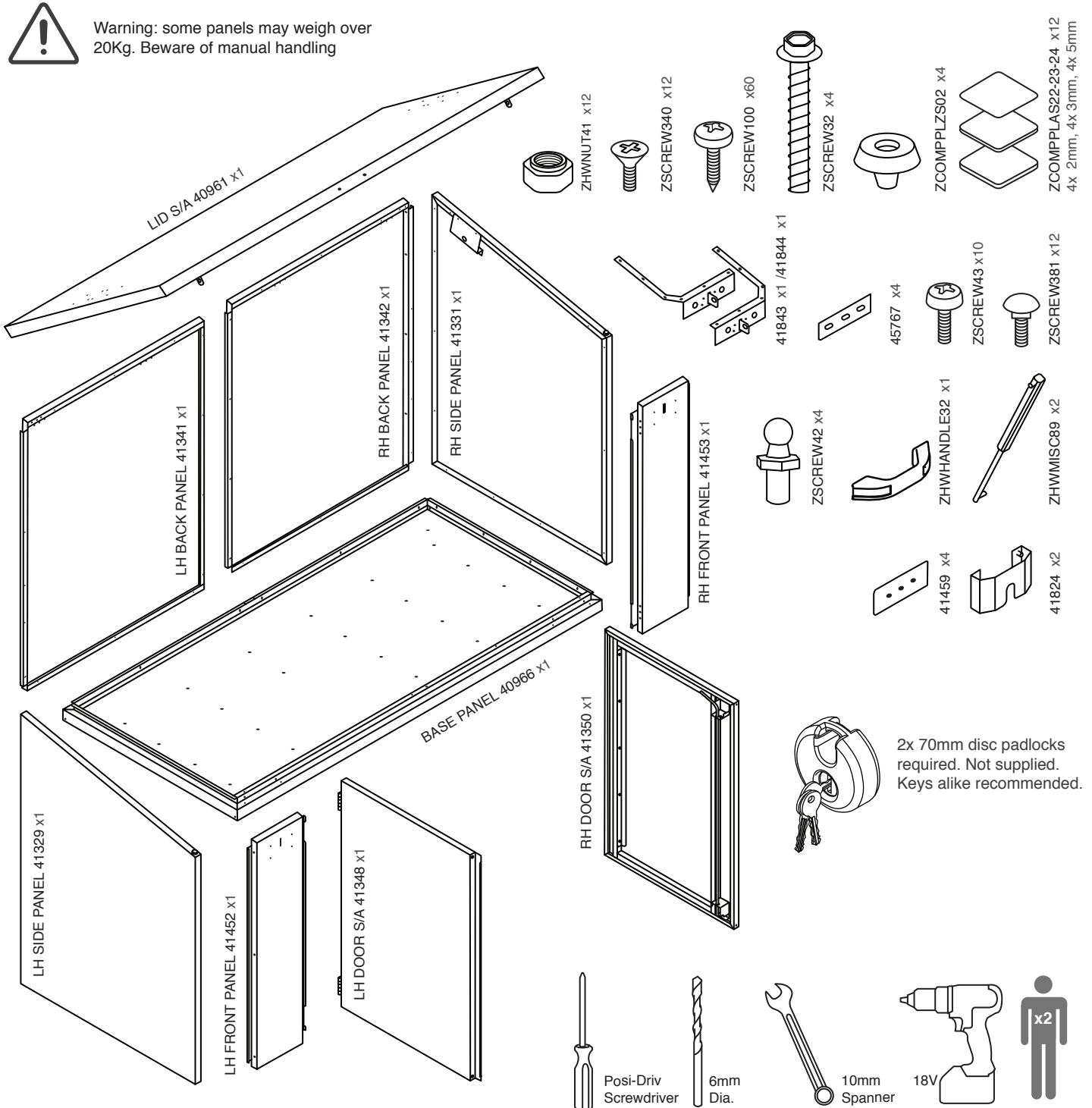

PLEASE NOTE ALL SCREWS ARE FIXED FROM THE INSIDE

1

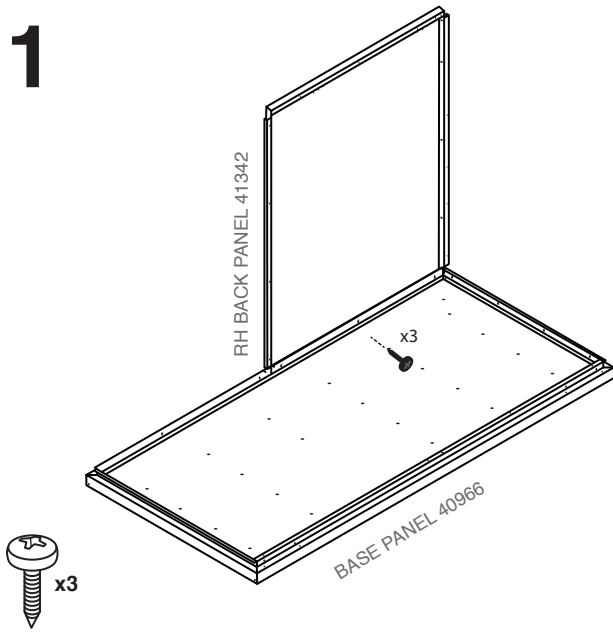

2

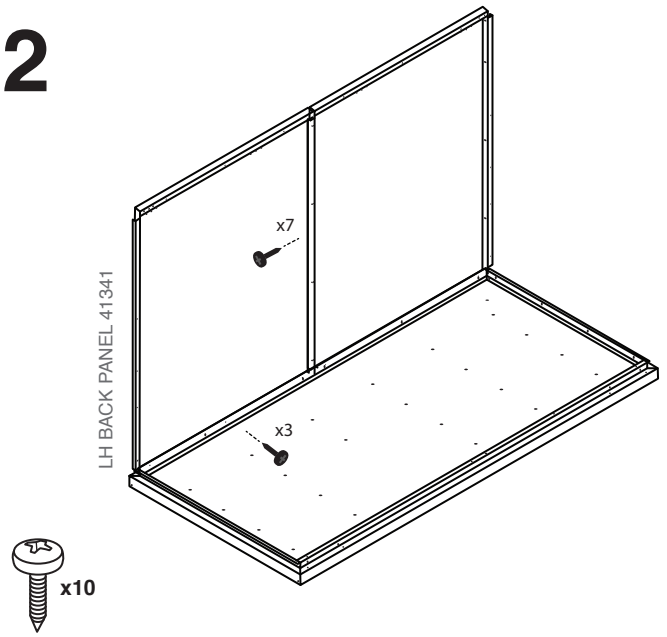

3

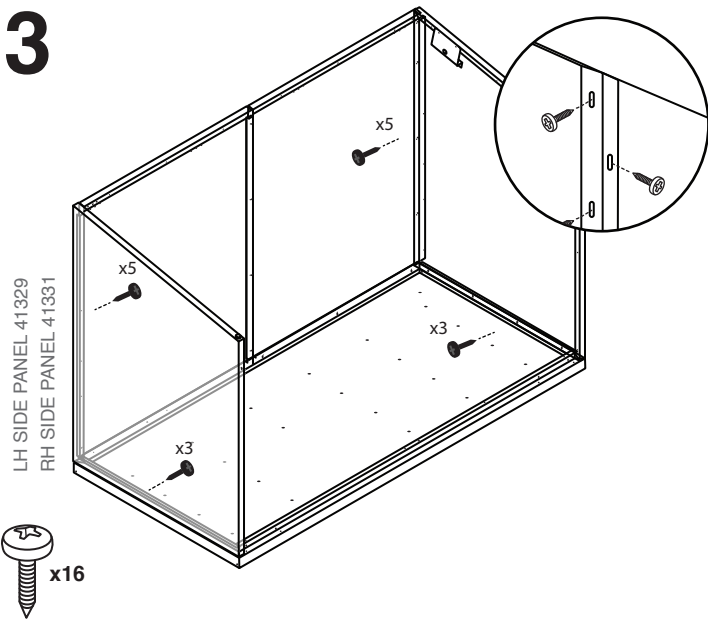

4

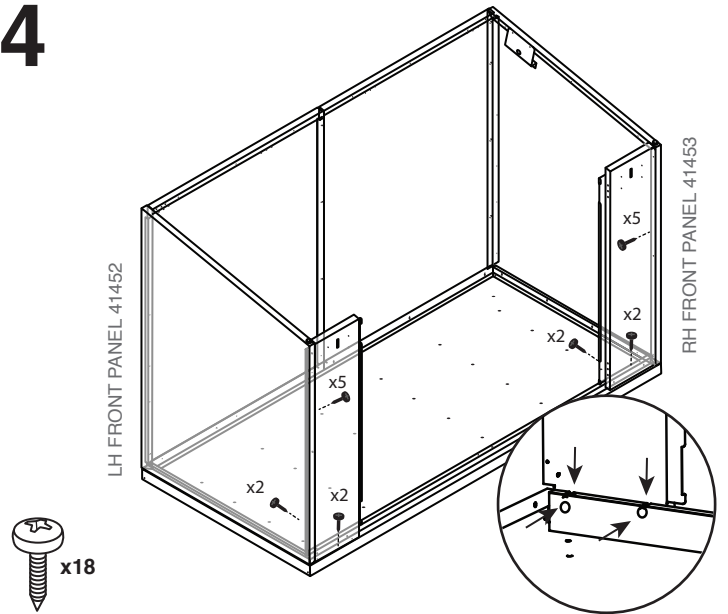

5

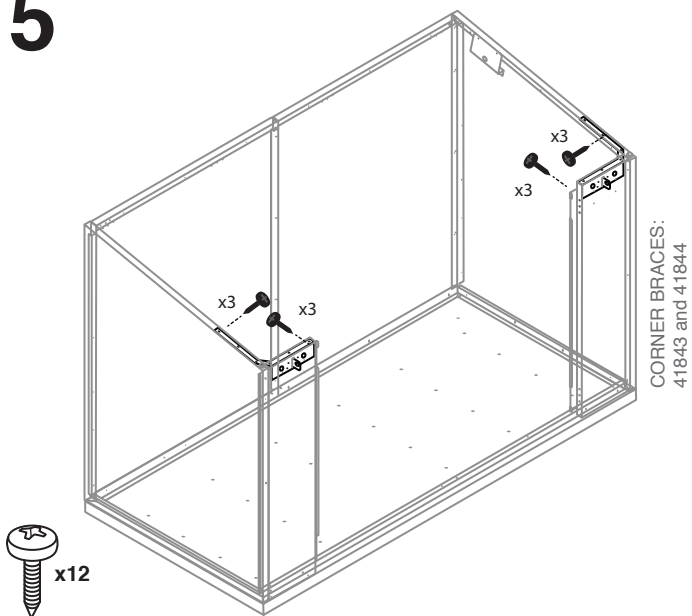

6

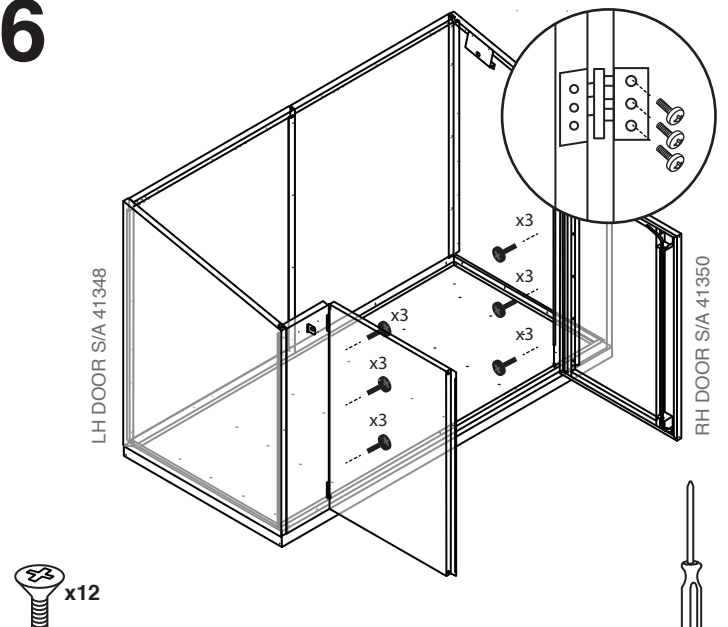

7

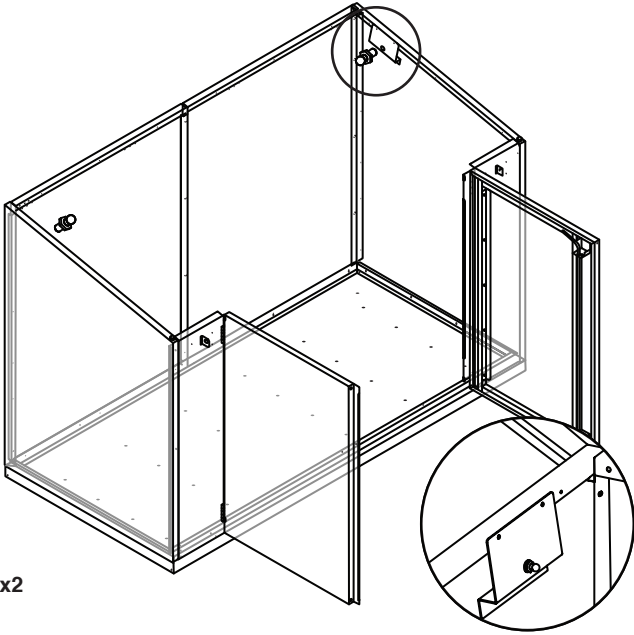

8

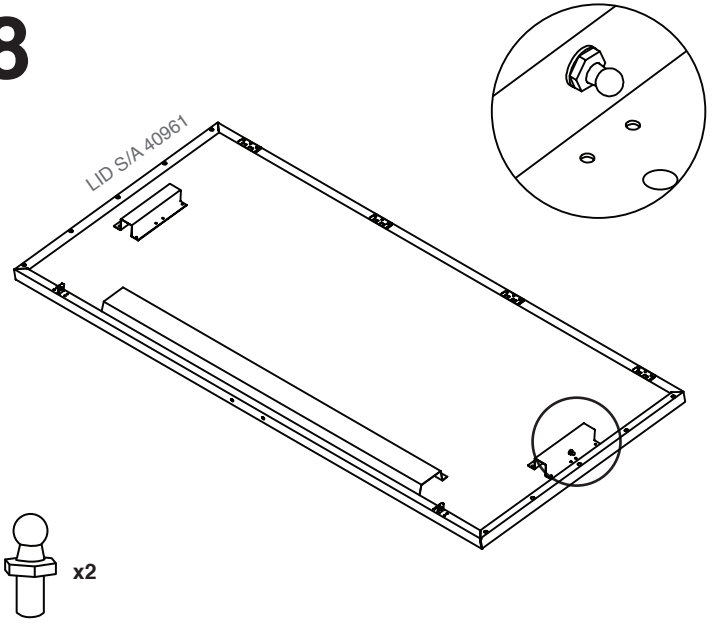

9

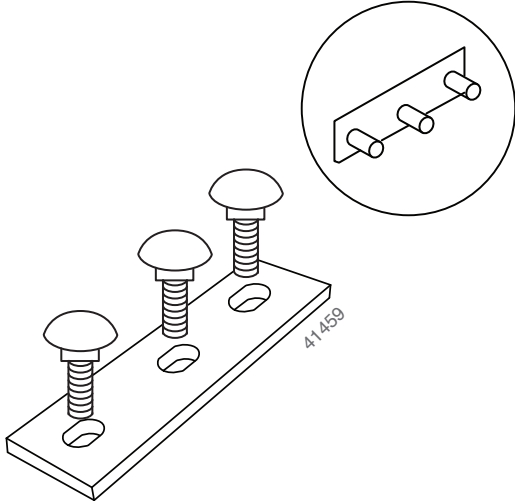

10

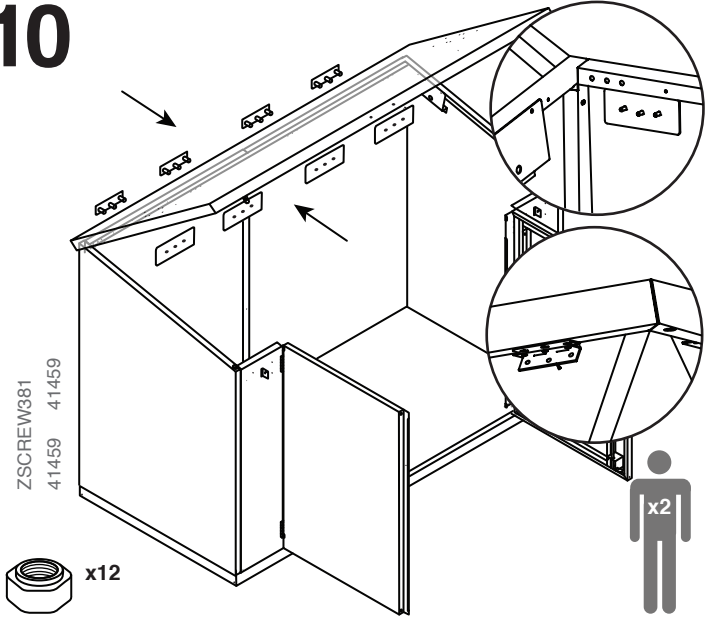

11

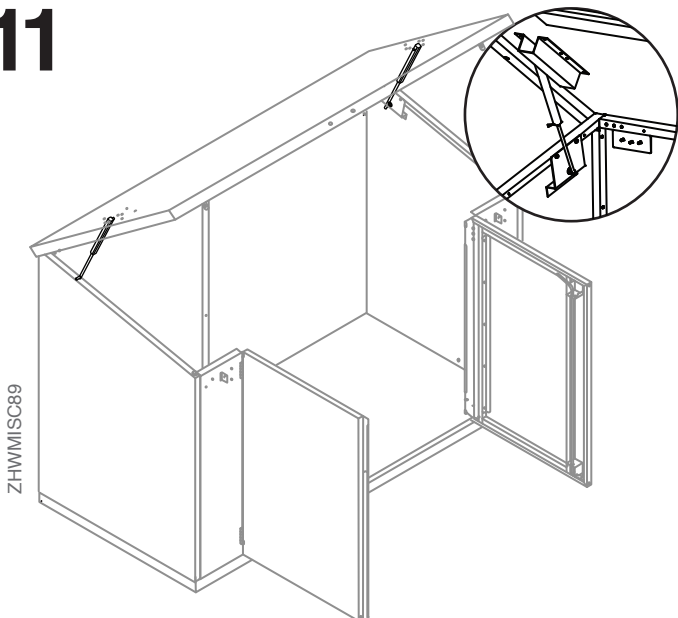

12

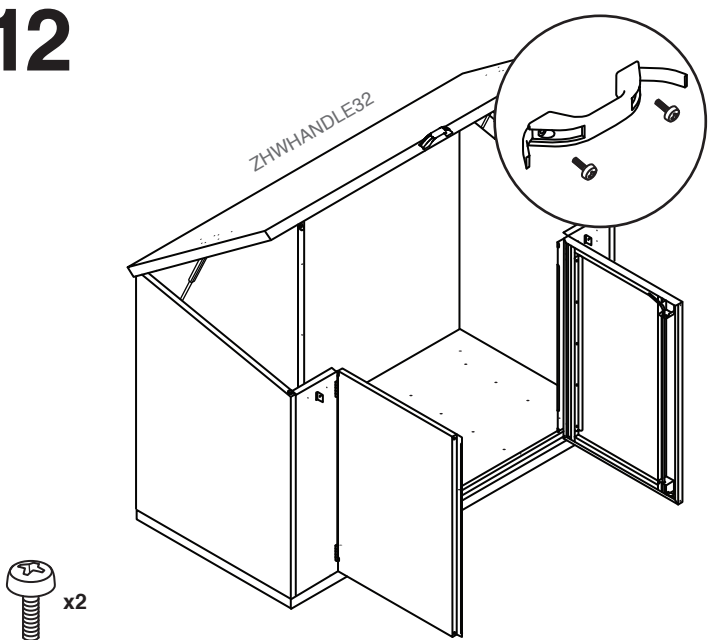

# 13

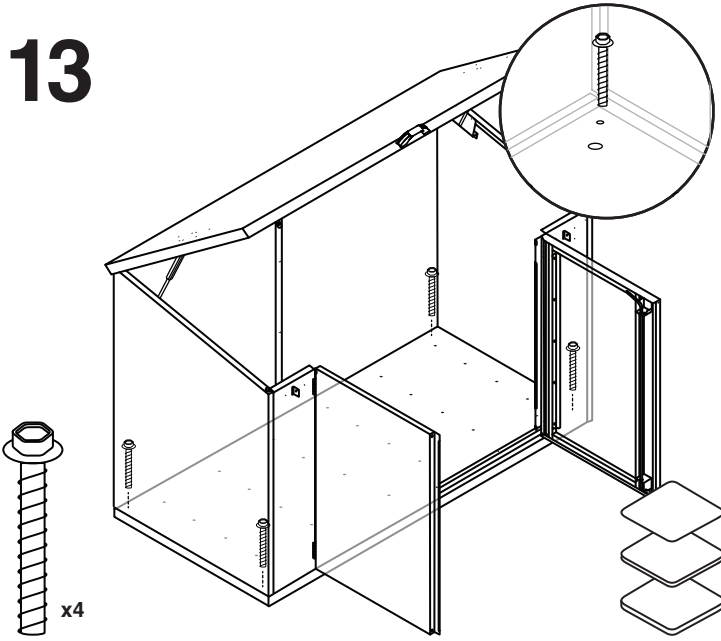

# 14!

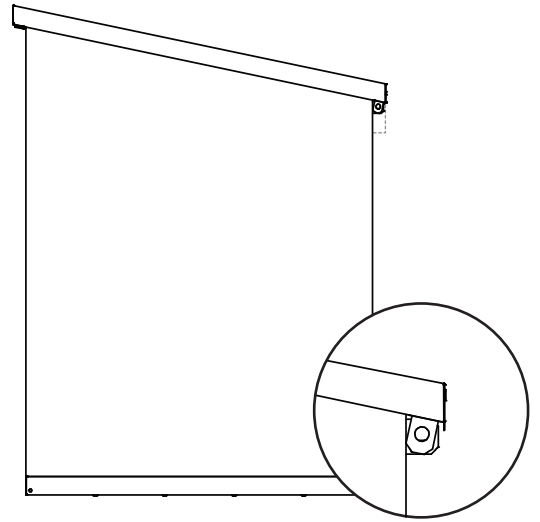
 ENSURE CORRECT ALIGNMENT BEFORE ATTACHING SHROUDS (41824)

# 15!

 FIT SHROUDS (41824) AS HIGH UP AS POSSIBLE