

UNTIL TECHNICAL APPROVAL HAS BEEN OBTAINED FROM THE RELEVANT AUTHORITIES, ALL DRAWINGS ARE ISSUED AS PRELIMINARY AND NOT FOR CONSTRUCTION. SHOULD THE CONTRACTOR COMMENCE SITE WORK PRIOR TO APPROVAL BEING GIVEN IT IS ENTIRELY AT HIS OWN RISK.

- CONTRACTORS MUST CHECK ALL DIMENSIONS ON SITE. ONLY FIGURED DIMENSIONS ARE TO BE WORKED FROM. DISCREPANCIES MUST BE REPORTED TO THE ARCHITECT OR ENGINEER BEFORE PROCEEDING. © THIS DRAWING IS COPYRIGHT.
- REPRODUCED FROM OS SETMAP © BY PERMISSION OF ORDNANCE SURVEY © ON BEHALF OF THE CONTROLLER OF HER MAJESTY'S STATIONERY OFFICE. © CROWN COPYRIGHT 2008. ALL RIGHTS RESERVED. LICENCE NUMBER: 10007126.
- UNTIL TECHNICAL APPROVAL HAS BEEN OBTAINED FROM THE RELEVANT AUTHORITIES, ALL DRAWINGS ARE ISSUED AS PRELIMINARY AND NOT FOR CONSTRUCTION. SHOULD THE CONTRACTOR COMMENCE SITE WORK PRIOR TO APPROVAL BEING GIVEN IT IS ENTIRELY AT HIS OWN RISK.

SUBJECT TO TECHNICAL APPROVAL

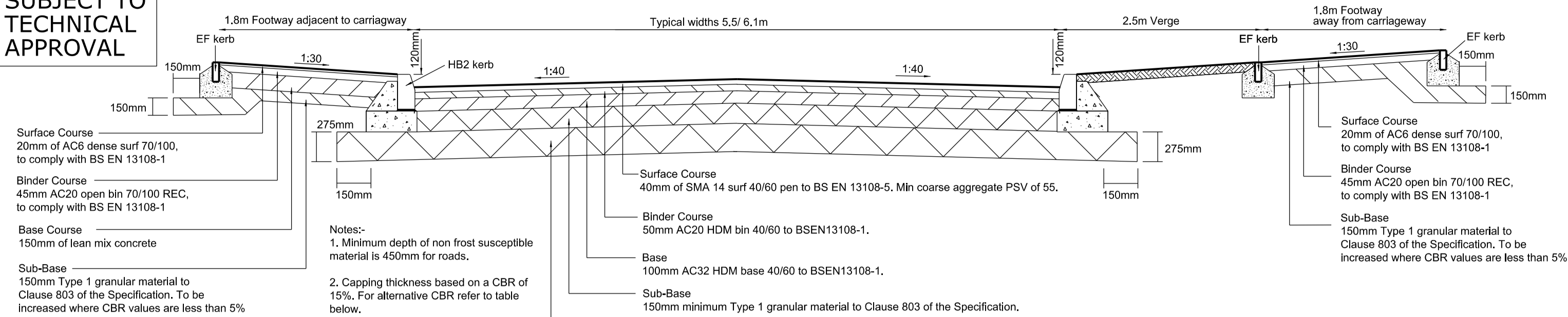

BLACKTOP CONSTRUCTION DETAIL

CBR	Capping thickness
2%	600mm
2.5%	400mm
3%	300mm
4%	300mm
5%	250mm
6%	240mm
7%	220mm
8%	210mm
9%	200mm
10%	190mm
11%	175mm
15% or more	150mm

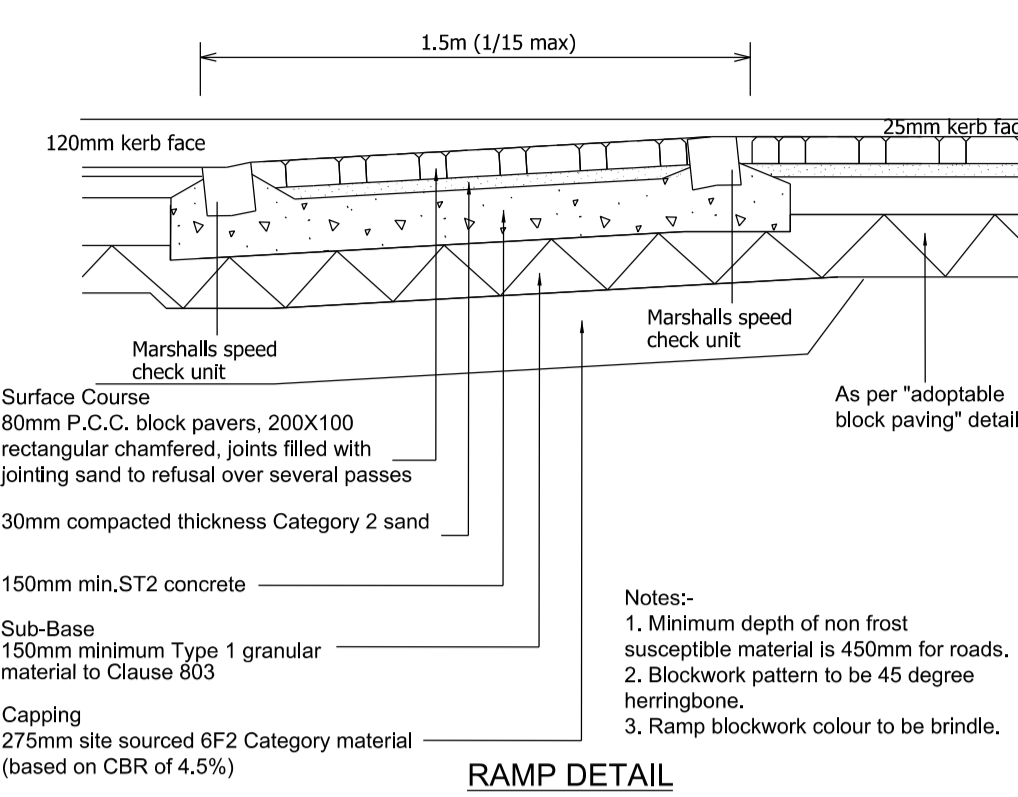

RAMP DETAIL

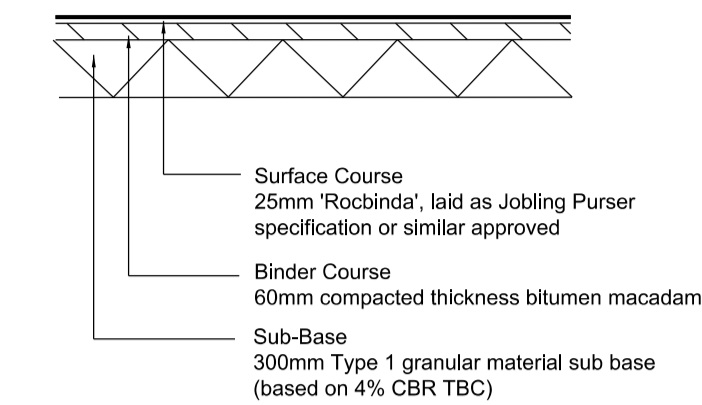

PRIVATE IMPERMEABLE DRIVE DETAIL

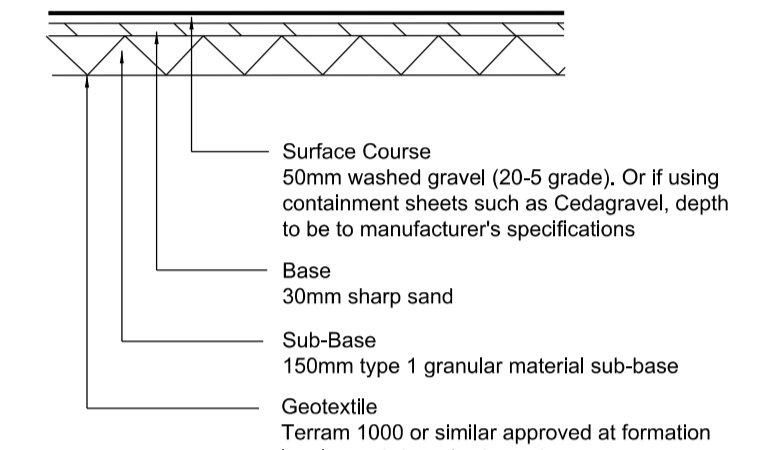

PRIVATE PERMEABLE DRIVE DETAIL

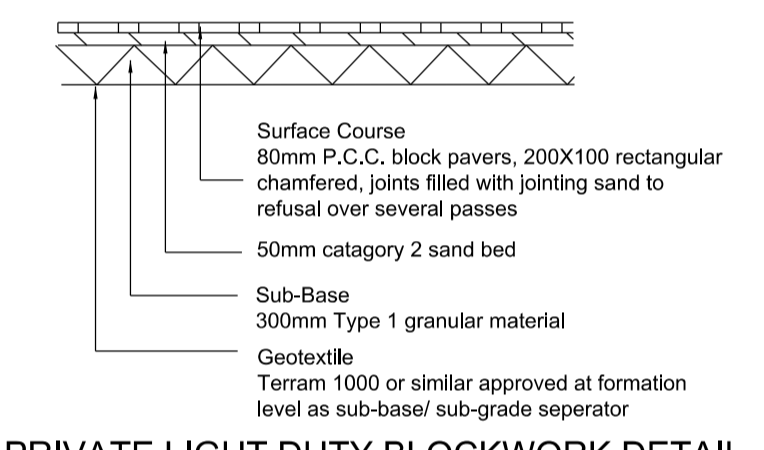

PRIVATE LIGHT DUTY BLOCKWORK DETAIL

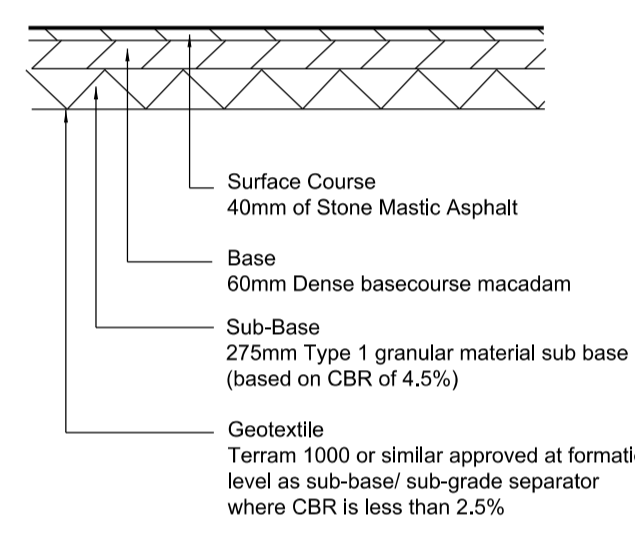

PRIVATE TARMAC DRIVE AND LIGHT DUTY ACCESS ROAD

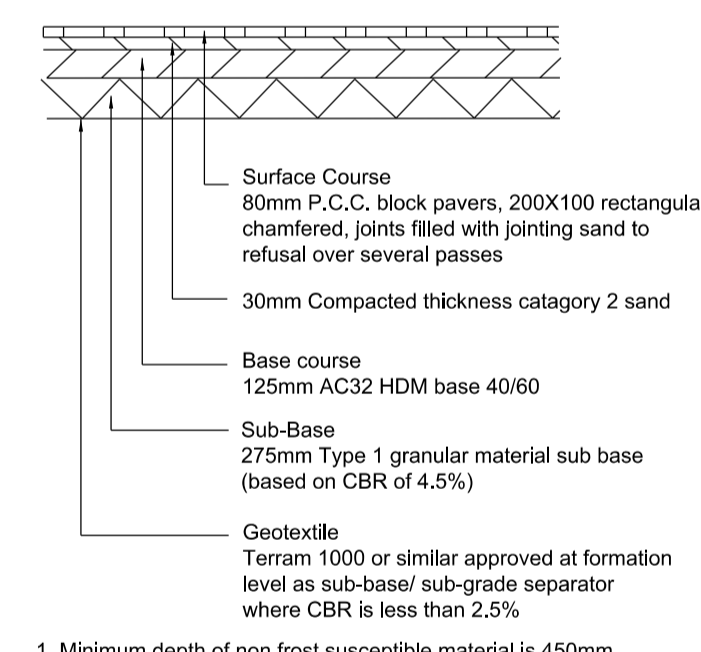

- Minimum depth of non frost susceptible material is 450mm.
- Blockwork pattern to be 45 degree herringbone.
- Shared surface blockwork colour to be charcoal.
- For use on adoptable highways and associated vehicular crossovers.

ADOPTABLE BLOCK PAVING/ PRIVATE BLOCK PAVING ACCESS

PRIVATE POROUS BLOCK PAVING DETAIL

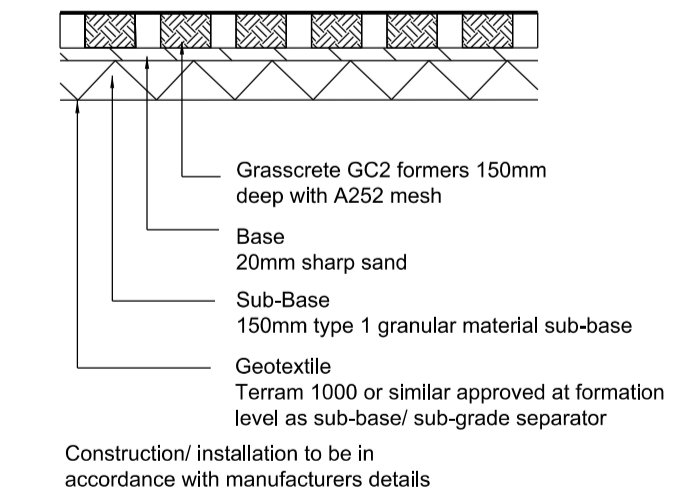

PRIVATE GRASSCRETE DETAIL

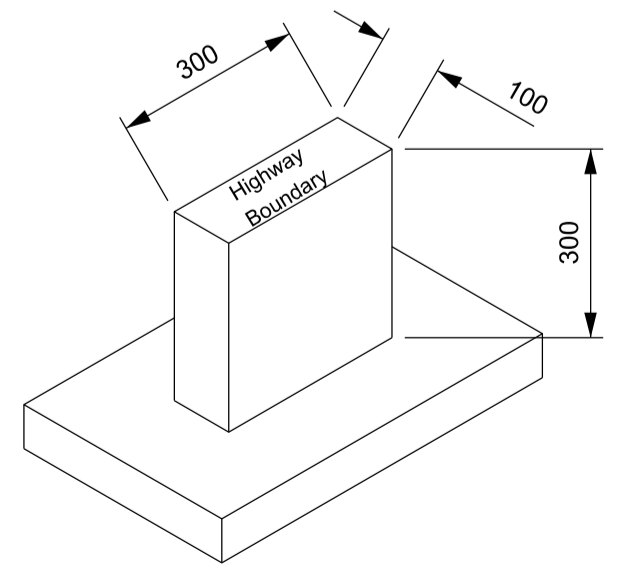

Within grassed areas the limit of adoptable Highway is to be indicated on site by means of concrete highway boundary markers positioned at intervals of 1 every 5m

The markers are to be concreted in position in grade ST4 concrete so that the top is flush with the verge in accordance with manufacturers recommendations

Where the highway limits are not readily identifiable in ungrassed areas i.e. where the highway boundary meets with a private drive and there is no change in surface material, a marker should be placed in a central position on the highway boundary

RC05 - HIGHWAY BOUNDARY MARKER DETAIL

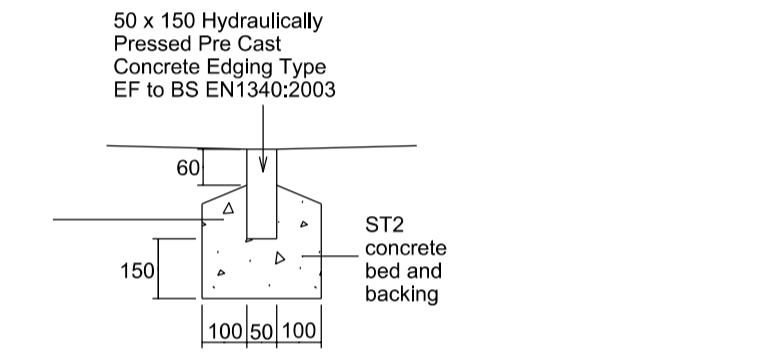

EDGING (EF)

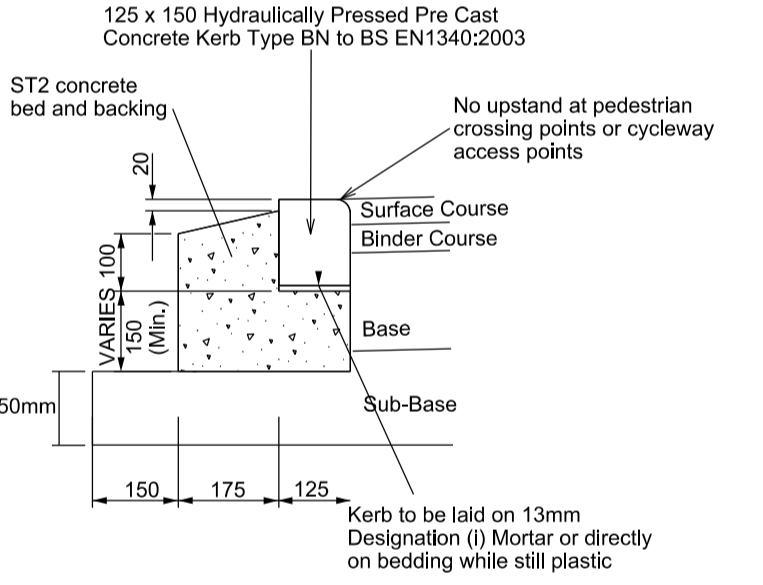

BULL- NOSED KERB (BN)

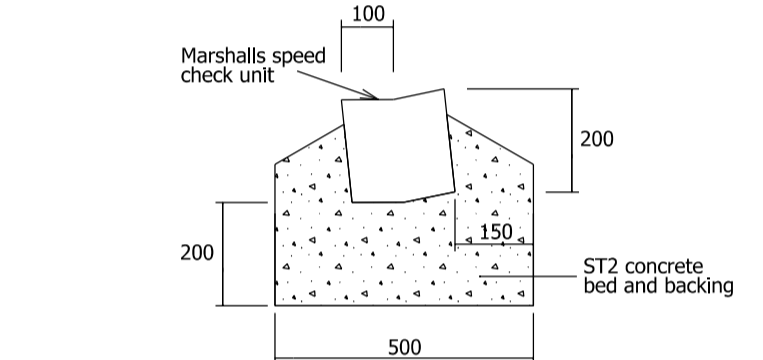

MARSHALLS SPEED CHECK UNIT
(Or similar approved)

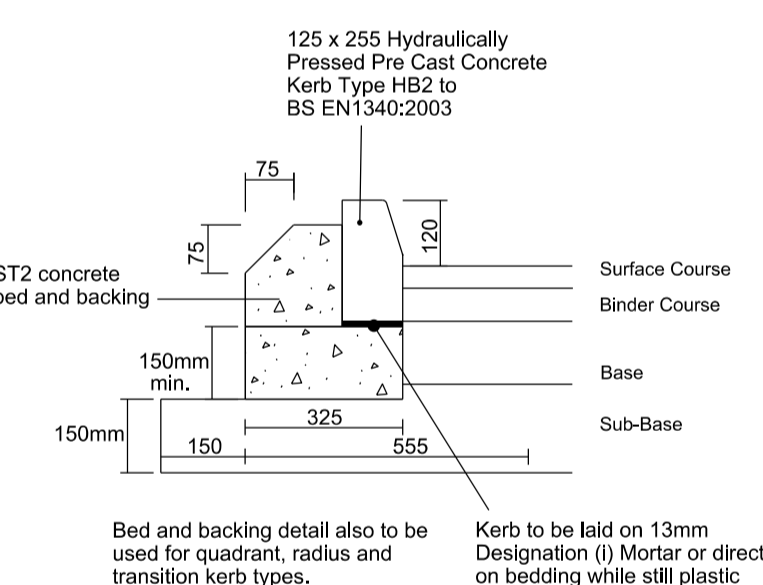

HALF BATTERED KERB (HB2)

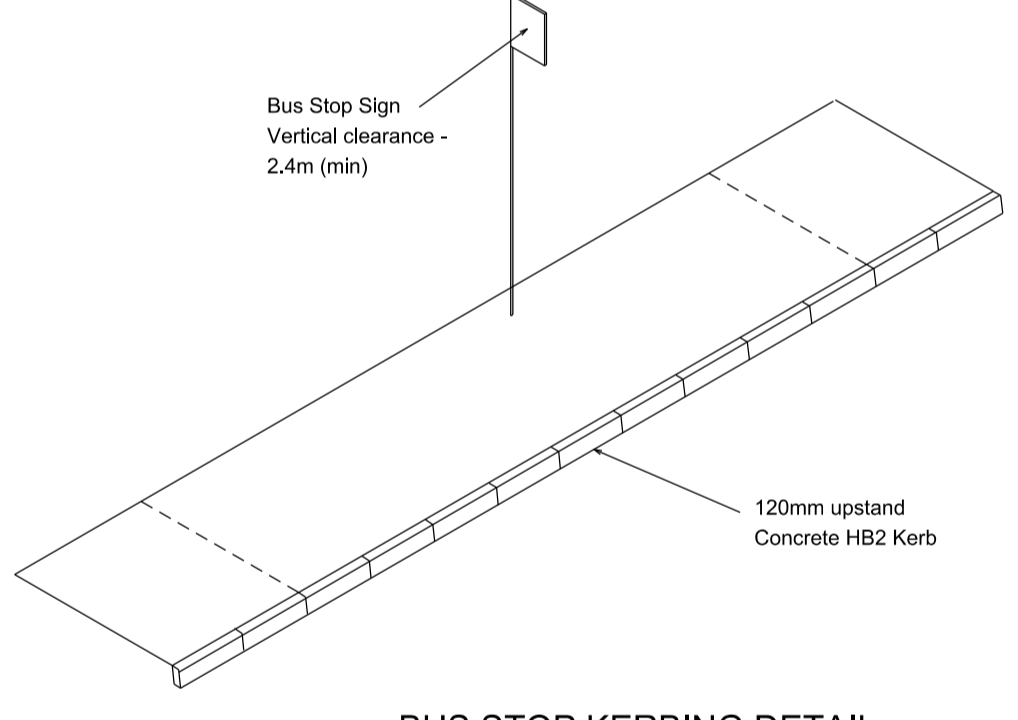

BUS STOP KERBING DETAIL

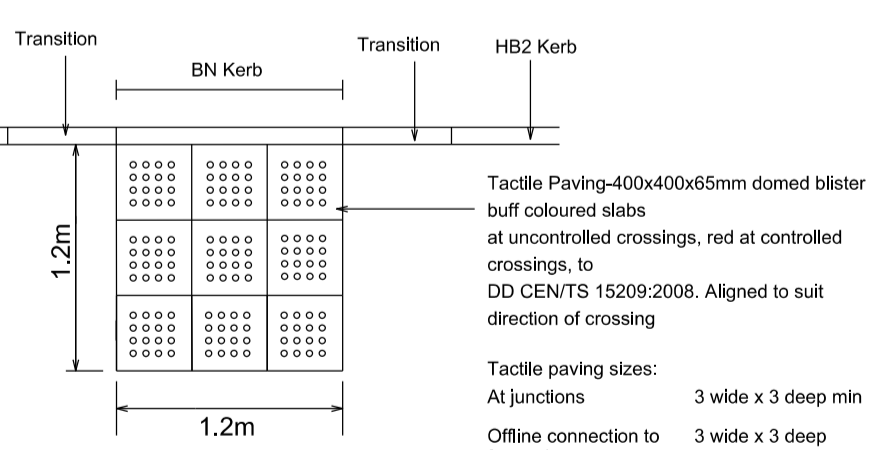

TACTILE CROSSING DETAIL

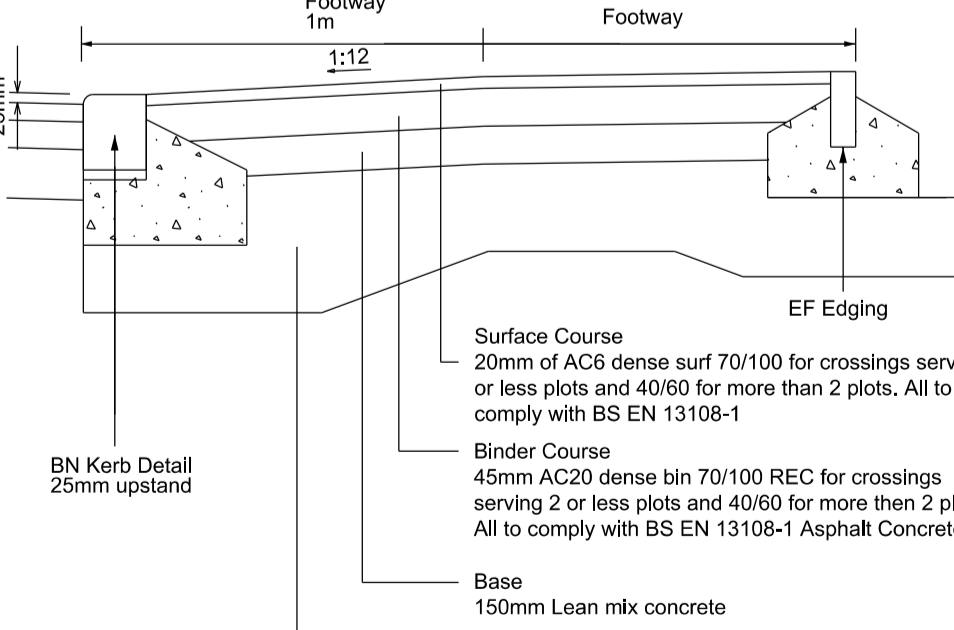

- For use on vehicular crossovers from/ to blacktop highways.

VEHICULAR CROSSING DETAIL

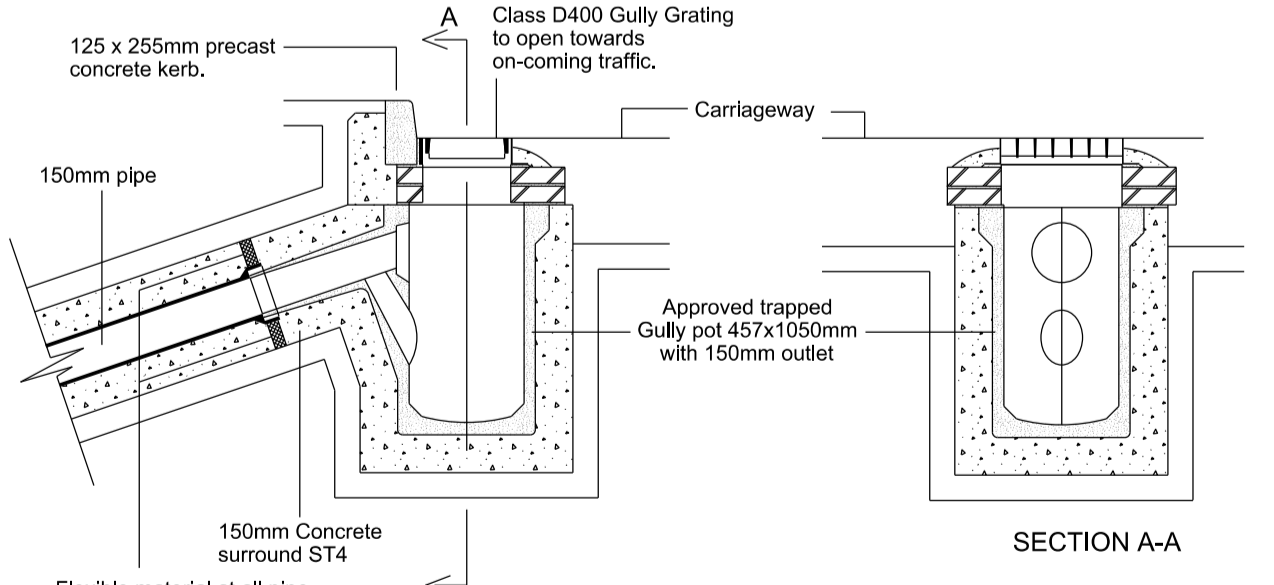

SECTION A-A

Flexible material at all pipe joints in concrete surround.

All gully pots to BS 5911 Pt 2. All grates and frames to comply with BS EN124 450mm in width. They shall be straight bar pattern. Gully grating and frames in access ways to be 325mm in width.

The grates and frames shall be bedded using Designation (I) mortar and set on minimum two courses and a maximum of 4 courses of Class B engineering bricks so that the top of the frames is below the finished channel level within the tolerance of -5mm to -10mm where measured adjacent to the kerbing. The gully frames shall be set to the carriageway gradient. Where the carriageway is constructed to the base course level for use as builders road, the gully frames should initially be set to base course level.

Class D400 gully grating and frame to open towards on-coming vehicles and be single piece, hinged, non-rock type to BS EN 124 (size 370 x 450mm) minimum waterway area 1000sqcm with straight bar pattern

Gully pots shall be 450mm internal diameter by 1050mm deep with 150mm diameter trapped outlet and rodding eye with C.1 stopper and chain. They shall be of an approved manufacture in precast concrete to BS 5911, salt glazed ware or Clayware to BS 65 and shall be laid with 150mm thickness of ST4 concrete. Connections to the sewer shall be by 150mm diameter clay or concrete pipes bedded on 150mm concrete and surrounded with ST4 concrete to a thickness of 150mm when the cover to the pipes is less than 1.2m.

Gullies should preferably connect directly into manholes, but, if this is not appropriate, they shall be connected to the main pipe by means of 45 degree oblique angled junctions, and surrounded by ST4 concrete to a thickness of 150mm. Gully connections shall not be longer than 20m.

GULLY DETAIL

REVISION	DESCRIPTION	DATE	BY	IF	DATE
A	Private details added		AT	JP	07.12.17

REVISION	DESCRIPTION	DATE	BY	IF	DATE
	PRELIMINARY				
	INFORMATION				
	TENDER				
	CONSTRUCTION				
	AS BUILT				