

1. TREE STOCK, GENERALLY

Scale 1:25

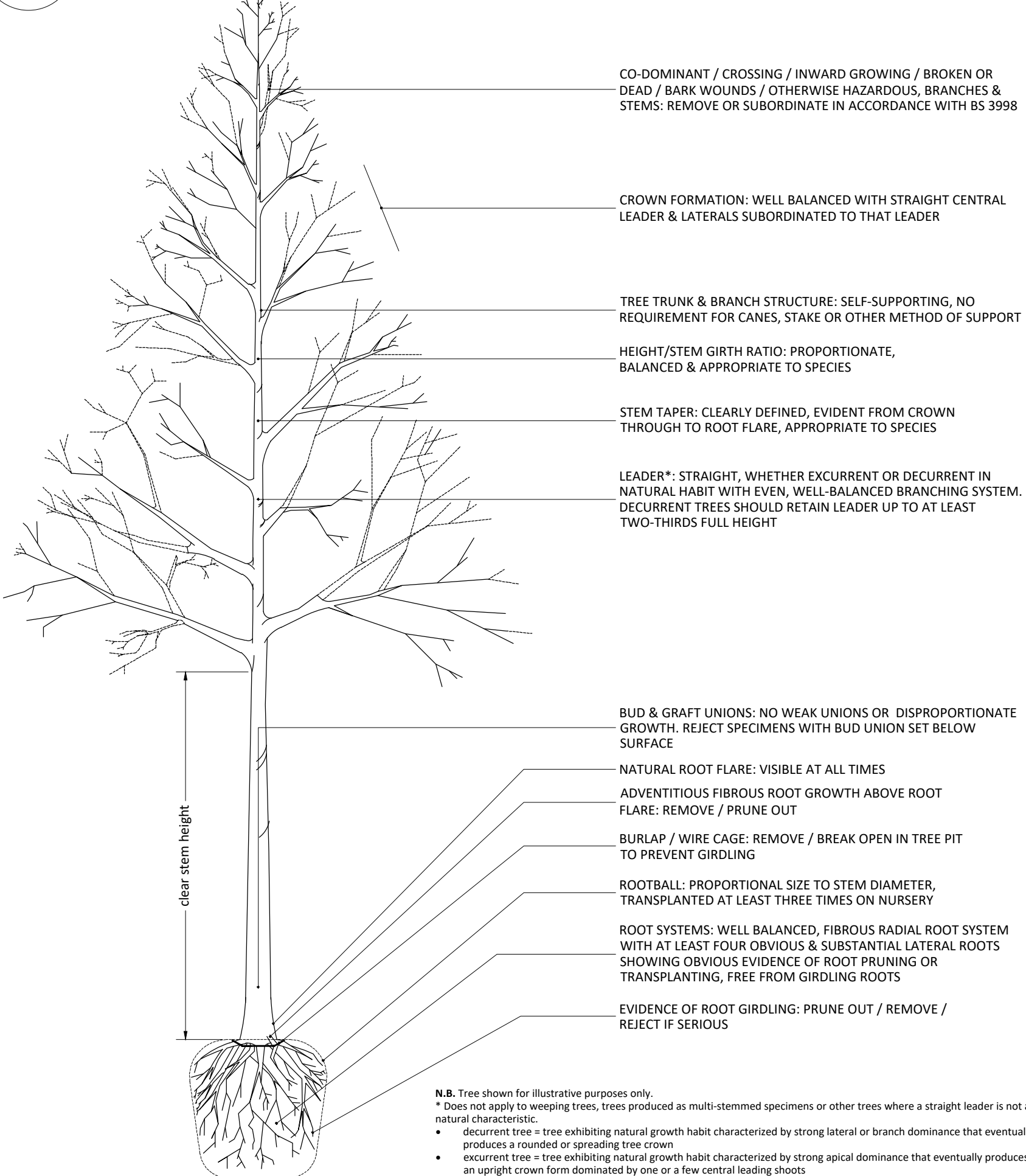

2. GENERAL TREE PLANTING PRINCIPLES IN OPEN GROUND

Scale 1:25

TREE SUPPORT SYSTEMS & IRRIGATION MEASURES OMITTED FOR CLARITY

TREE PIT: PLAN VIEW

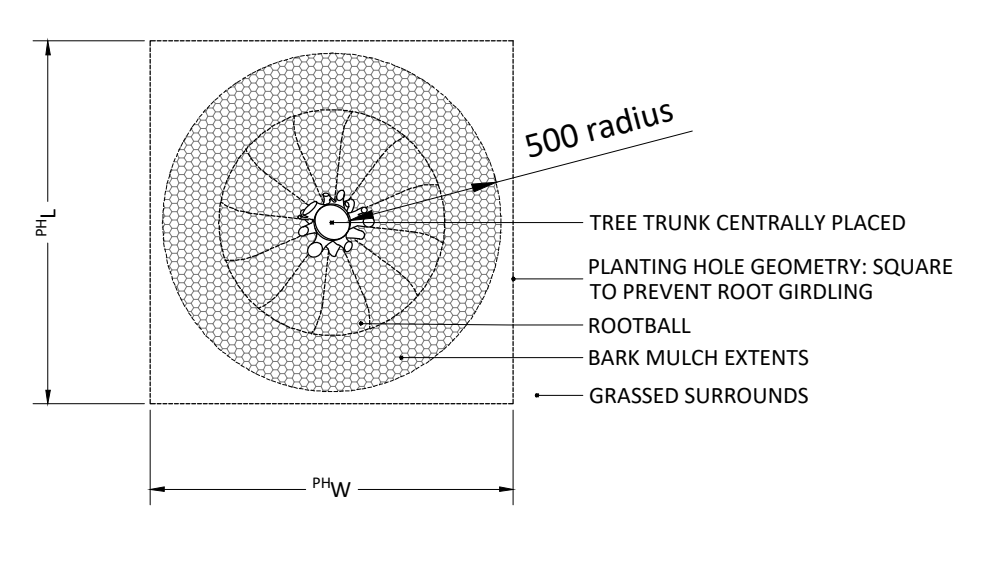

SECTION ELEVATION

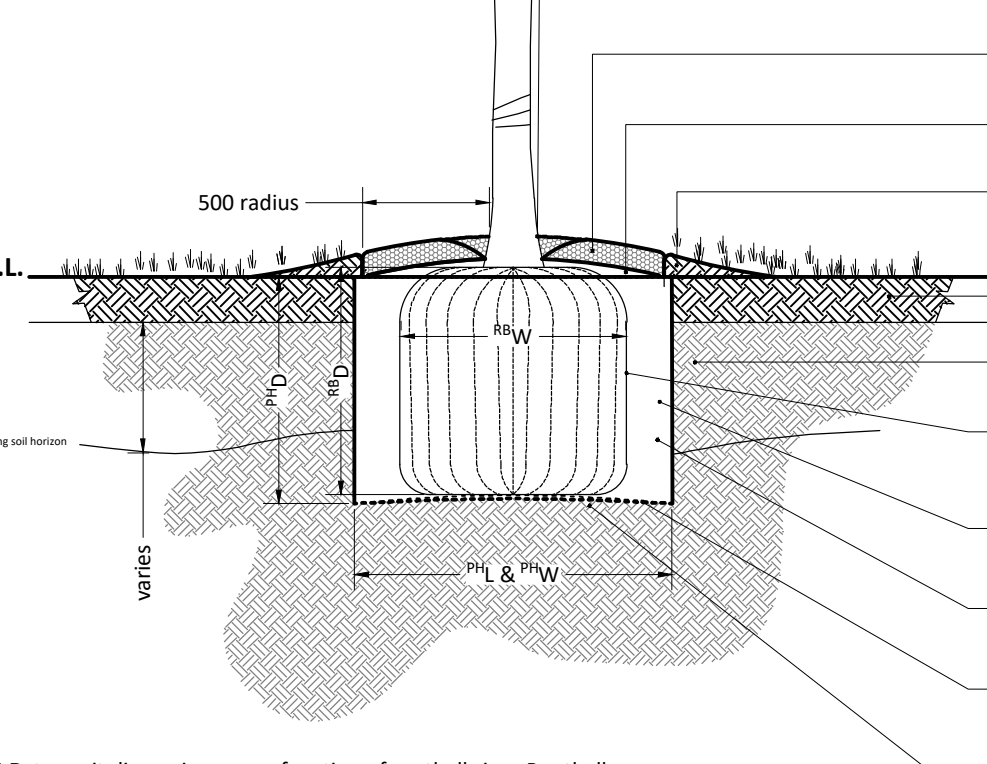

N.B. tree pit dimensions are a function of rootball size. Rootball dimensions are dependant on size of tree specified. Refer to Table 1.

N.B.

- BS 8545: 2014 states that, "Sensible tree pit design begins with the intention of doing as little as possible other than digging a pit, planting the tree, and using the existing soil, separated as subsoil and topsoil, as backfill. Each additional level of complexity added to the basic pit design can be related to the amelioration of a particular constraint".
- Tree shown planted in open ground in optimal conditions with minimal site constraints.
- Tree support systems are omitted for clarity.
- Tree pit dimensions are a function of rootball size. Rootball dimensions are dependant on size of tree specified. Refer to table.

3. ABOVE GROUND SUPPORT TREE STAKES

Scale 1:25

TRIPLE STAKED (Tst)

PLAN VIEW - AG

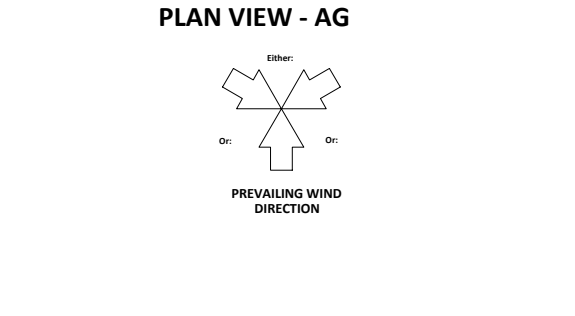

N.B. tree pit dimensions are a function of rootball size. Rootball dimensions are dependant on size of tree specified. Refer to Table 1, detail 2

SECTION ELEVATION - AG

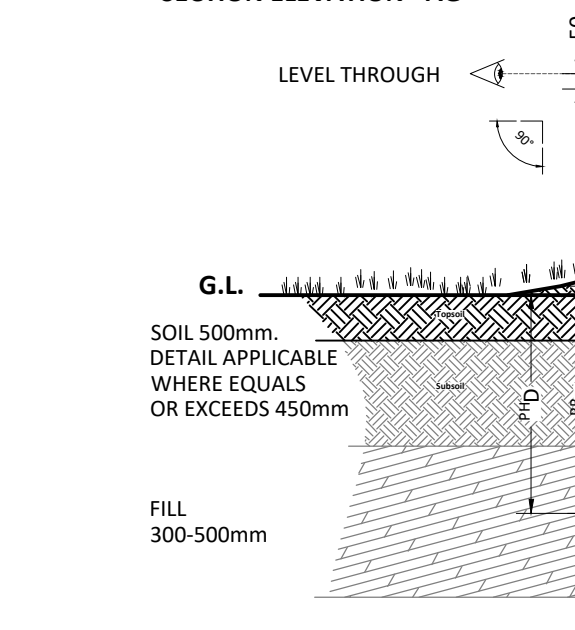

SINGLE STAKE - (Sst) TO REAR GARDENS

PLAN VIEW

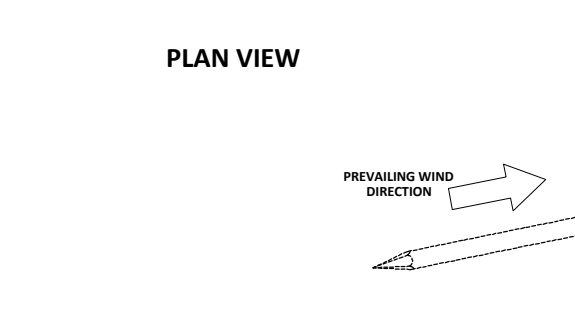

SECTION ELEVATION

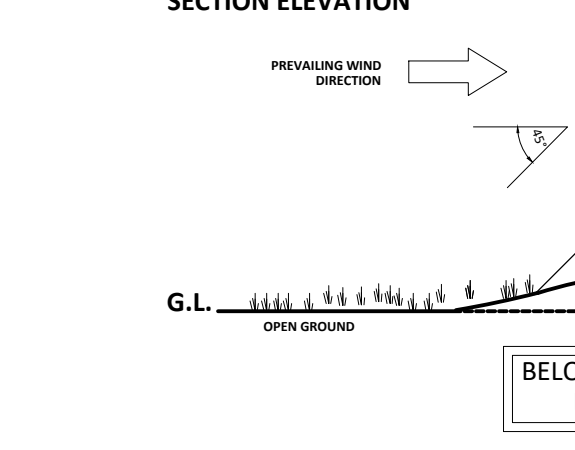

5. BELOW GROUND TREE SUPPORT UNDERGROUND GUYED (UG) TREES

Scale 1:25

PLAN VIEW - UG

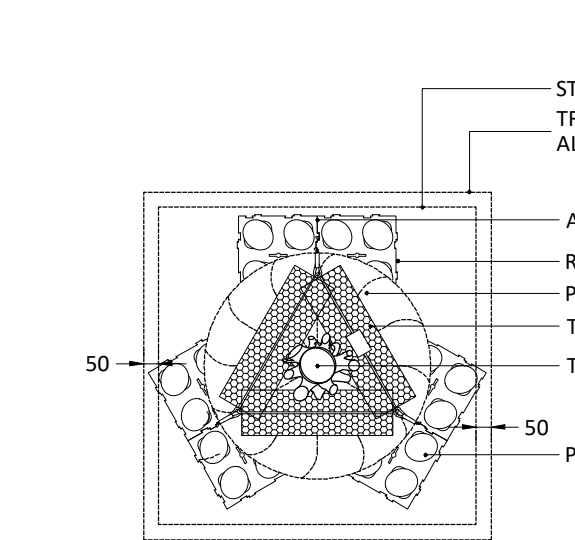

SECTION ELEVATION - UG

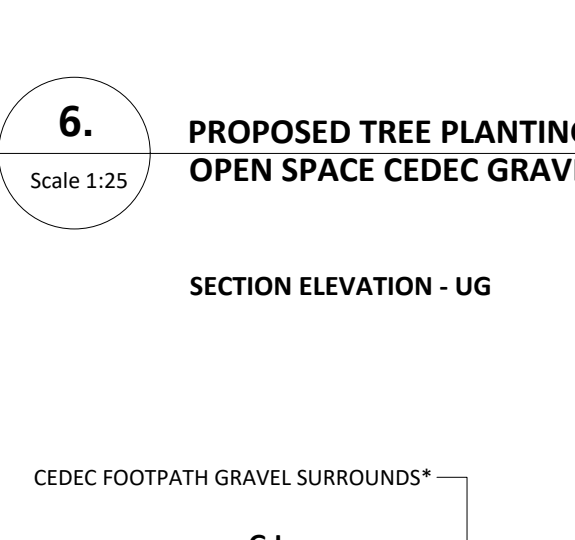

6. PROPOSED TREE PLANTING IN HARD SURFACES OPEN SPACE CEDEC GRAVEL PATHS

Scale 1:25

SECTION ELEVATION - UG

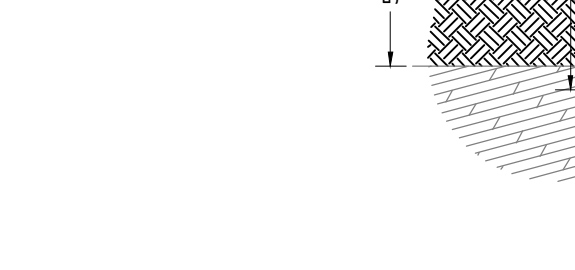

DOUBLE STAKE & CROSS BAR - (DstXb)

PLAN VIEW



IN AREAS SUBJECT TO: HIGH WIND LOADING / VANDALISM; TRIPLE STAKED TREES MAY BE SUBSTITUTED FOR A DOUBLE STAKE & CROSS BAR

SECTION ELEVATION

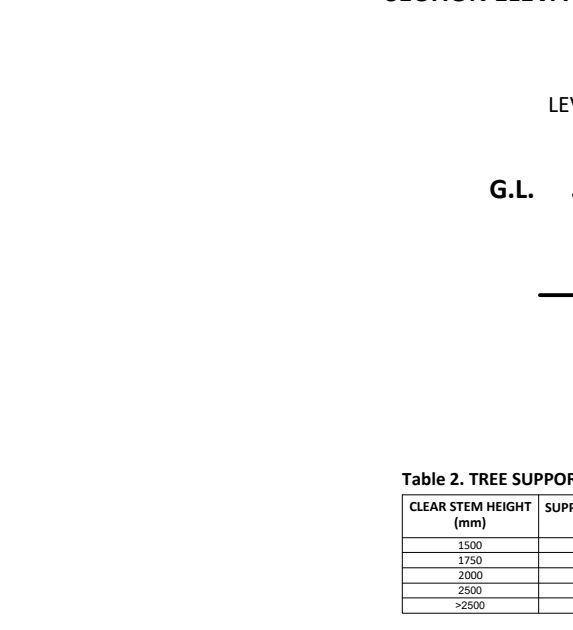

4. ABOVE GROUND SUPPORT TREE STAKES

Scale 1:25

STAKE TYPE ORIENTATION IN PROXIMITY TO TRANSPORT CONDUITS / AVENUE / SPINE ROAD PLANTING / ETC.

PLAN VIEW

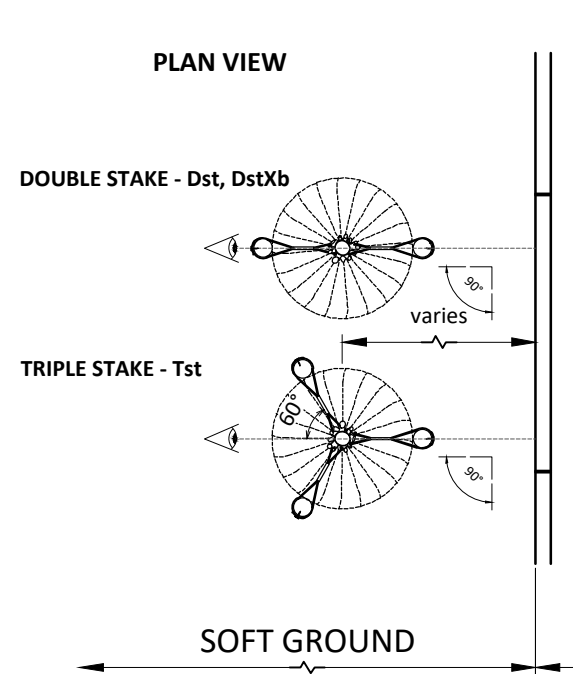

Table 2. TREE SUPPORT HEIGHTS

CLEAR STEM HEIGHT (m)	SUPPORT HEIGHT (m)
1.00	1.00
1.50	1.50
2.00	2.00
2.50	2.50
3.00	3.00
3.50	3.50
4.00	4.00
4.50	4.50
5.00	5.00
5.50	5.50
6.00	6.00
6.50	6.50
7.00	7.00
7.50	7.50
8.00	8.00
8.50	8.50
9.00	9.00
9.50	9.50
10.00	10.00

Table 3. ABOVE GROUND TREE SUPPORT ORIENTATION IN RELATION TO TRANSPORT CONDUITS / SPINE ROADS / AVENUES / ETC.

STAKE TYPE	ORIENTATION	REASON
DOUBLE	PERPENDICULAR	Visual Amenity / Protection from Wind Damage
TRIPLE	PERPENDICULAR	Visual Amenity / Protection from Wind Damage

Table 4: UNDERGROUND GUYING SCHEDULE

ITEMS	SPECIFICATION
EARTH ANCHORING SYSTEM:	UNDERGROUND GUYED
MANUFACTURER:	PLATIPLUS
MODEL:	D-MAN
D-MAN CELL DIMENSIONS:	270x270x80mm (LxWxD)
CODE:	RFP2DMAN
SUITABLE FOR:	12-45cmg TREES
SYSTEM COMPRISING:	3no. Wire Chokes, 5m galvanised wire, 1no. ratchet tensioner, 3no. Plati-Mats, 6no. D-MAN cells (3 x 2no. cells connected).

N.B. Earth Anchoring Systems are to be installed to manufacturer's recommendations & requirements with a minimum of 3no. earth anchors & associated cables to be fitted per tree.

The RFP2DMAN system has been preferentially selected over the RFP2DMAN system b/c of adverse site conditions (exposure, wind & ground conditions).

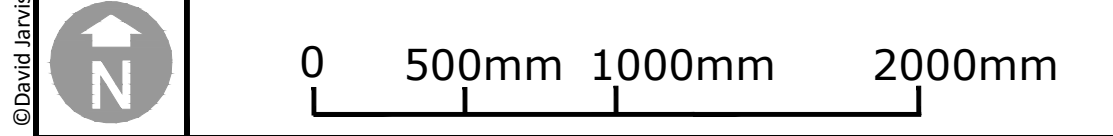

GENERAL TREE PIT PLANTING NOTES:

- SPECIFIED MATERIALS:** all to be installed in accordance with the manufacturer's recommendations and/or instruction.
- PLANTING GENERALLY:** Correct planting depth is critical for transplanting success, with over-deep planting identified as a common cause of failure. The Contractor shall therefore ensure that the natural root flare of the tree is clearly visible at proposed finished soil surface. To ensure that correct final planting position / depth is achieved, the Contractor shall therefore take care to remove all:
 - soil placed above natural root flare during nursery packaging & production - rootballing, containerisation, etc.
 - adventitious roots above the root flare.
 - wire encircling the main stem.
 - wire cage & burlap where possible. Otherwise, peel back and remove once the tree is in the planting pit.
- BACKFILL MATERIAL:** Open ground & Verges: select 'as dug' material to be reused taking care to match adjacent soil horizons (where suitability assured for tree growth); TBC onsite by Contractor. All 'as dug' material to conform to BS 3882:2007 General Purpose Topsoil. Remove all deleterious material arising (weeds, broken brick & large stones, etc). Backfill & lift in layers no greater than 150-230mm deep. Compact to between 1.5 - 2.0 mega pascals: tread down using footfall, paying particular attention to the planting hole edges and rootball extents to eliminate voids. Avoid over compaction. **Hard Paved Surfacing:** Use Heicom Tree Soil within primary rooting zone to manufacturer's instruction. Compact to manufacturer's recommendations. Backfill loose & dry (as approx. 20% is lost by volume upon compaction) into the tree pit. Lift in layers no greater than 250-300mm deep, and compact to between 1.5 - 2.0 mega pascals making sure the material is dry as proper compaction cannot be achieved when wet, paying special attention to the edges of the tree pit. A calibrated Penetograph can be used by a specialist approved by the soil supplier, and employed by the Contractor who installed the soil, to assess and confirm the level of compaction. The corresponding graph should be supplied to both the Project Structural Engineer, the Landscape Contractor & the Contract Administrator for information, before tree planting commences. **N.B.** In the event that trees are to be installed into the root director post completion of surfacing & construction build-up; the contractor shall take care to install the root director to the correct depth, form and level, and ensure that the root director void is filled and compacted with the specified tree soil prior to the commencement of associated surfacing and construction build up. Reason: to prevent the root director from being crushed during the construction build-up process. This temporary fill can then be dug-out at tree planting to accommodate the rootball.
- BACKFILL SOIL AMELIORANTS:** the Contractor shall satisfy himself of the general suitability of the topsoil supplied for long term tree growth. Reason: to ensure the long term longevity of the tree supplied. Thereafter: to suit site conditions. Typically, this may comprise 5kg of broadleaf pit or similar (pre-hydrated with water) thoroughly mixed with the topsoil until the medium is homogeneous.
- ARISINGS:** all deleterious material arising shall be removed off-site to a licensed tip by the Contractor.
- TREE SUPPORT SYSTEMS:** Unless otherwise stated, all trees within public open spaces shall be supported as identified on the Software drawings which use both the Triple Stake (Tst) & Underground Guyed (UG) method of tree support. In the case of high wind loading / vandalism, the Triple Stake & Crossbar method may be substituted for the Double Stake & Crossbar (DstXb) method. In rear gardens the Single Stake (Sst) method shall be used.
 - Tree support stakes along transport conduits are to be orientated in accordance w/ Detail 3 opposite.
 - Tree support stakes to butt up against the rootball to help stabilise it.
 - Tree support height above ground shall be as identified on Detail 3.
 - Stakes to be removed to a minimum 150mm below ground level with no sharp edges as soon as the developing root system is self-supporting & root firmness is proven.
 - Irrigation pipes to be installed around the AG tree support system & top of the UG tree support system.
- ROOT PROTECTION MEASURES:** supply & install permeable rootbarriers (Teram RootGuard, or equal & approved) to a min. depth of 600mm below ground. Installation: as per manufacturer's instruction. Finished level: top of barrier to be 10mm above G.L. **Zone of Deployment:** protection of hard surfacing / services lying within a min. 5m radius of the proposed tree and as detailed on plan.
- IRRIGATION:** Open ground & Verges: Create topsoil chaucer as Detail 2. Water at frequency necessary to ensure establishment & survival.
- DRAINAGE:** the contractor shall satisfy himself that the tree pit is free draining. The contractor shall notify the Contract Administrator of any problem areas and await further instruction before proceeding further. Reason: to ensure the longevity & viability of the tree supplied. TBC onsite.
- BARK MULCH:** Amenity, 8-40mm particle size, mid dark brown, Rolawn (or equal & approved). Coverage: 75mm deep, 1m Ø around base of tree.

NOTES

Related Drawings: This is a composite drawing based on information received from other consultants.

Issue: Drawn by David Jarvis Associates Limited (CROWN COPYRIGHT. ALL RIGHTS RESERVED 2015 LICENCE NUMBER 030003). This Drawing is for Planning purposes only. Do not use this drawing for Construction. The information contained in the drawing should be used in a specific final form and finished by the landscape scheme. Any revision to be approved by the Client and Local Authority.

Scale: Refer to each drawing. Use given dimensions only.

Setting out: refer to Engineers for information regarding setting out. In the event of discrepancy refer to Engineers in the first instance.

Survey: Original survey provided by the Client.

Planting: Plant species are selected and located in line with consideration of the site conditions, NERC guidelines and discussions with the Local Authority and other stakeholders. All plants and planting provided to conform to the David Jarvis Associates Limited Landscape Specification that will accompany the Construction Issue drawing. No species or plant location is to be varied without prior consent of the Landscape Architect.

Tree Root Protection Measures: supply & install permeable rootbarriers (Teram RootGuard, or equal & approved) to a min. depth of 600mm below ground. Installation: as per manufacturer's instruction. Finished level: top of barrier to be 10mm above G.L. Zone of Deployment: protection of hard surfacing / services lying within a min. 5m radius of the proposed tree. To be increased to 200mm depth where services / utilities require to be accommodated. To be determined by the Landscape Architect.

Foundation: Developers / Contractors to ensure that all foundations (buildings and external walls) are designed and constructed so as to take into account, at the time of maturity, any existing or proposed trees, hedgegroves or other vegetation on the application site or existing vegetation on land adjoining the site at the time of construction and any trees listed or hedgegroves removed or adjacent to the site during the previous 15 years. For this purpose the developer / contractors will submit all relevant details to the authority dealing with the Building Regulation certificate.

Design Levels: Refer to Engineers where design levels are not shown.

Code: Drawings to be read in conjunction with Designers risk assessment. Potential risks above that of those associated with the general construction typical to the drawing are identified below:

Drawing Revision

Rev.	Date	Description	DRN	CKD
01	04/12/2017	Final Issue	MS	SL

Status

PLANNING

DAVID JARVIS ASSOCIATES

DAVID JARVIS ASSOCIATES LIMITED
 1 Tennyson Street Swindon Wiltshire SN1 5DT
 t: 01793 612173
 e: mail@davidjarvis.biz
 w: www.davidjarvis.biz

Client

ELMSBROOK (CREST A2D) LLP

Project

ELMSBROOK, BICESTER PHASES 3 & 4

Drawing Title

TYPICAL TREE PLANTING DETAILS

Scale: **1:25** Sheet Size: **A1** Date: **04/12/2017**

Drawing No. **14790/5500** Revision: **P1**