

HOUSE TYPE - SP8
 PLOT : 365,369,378,381
 405,408

W4,W6 & W7

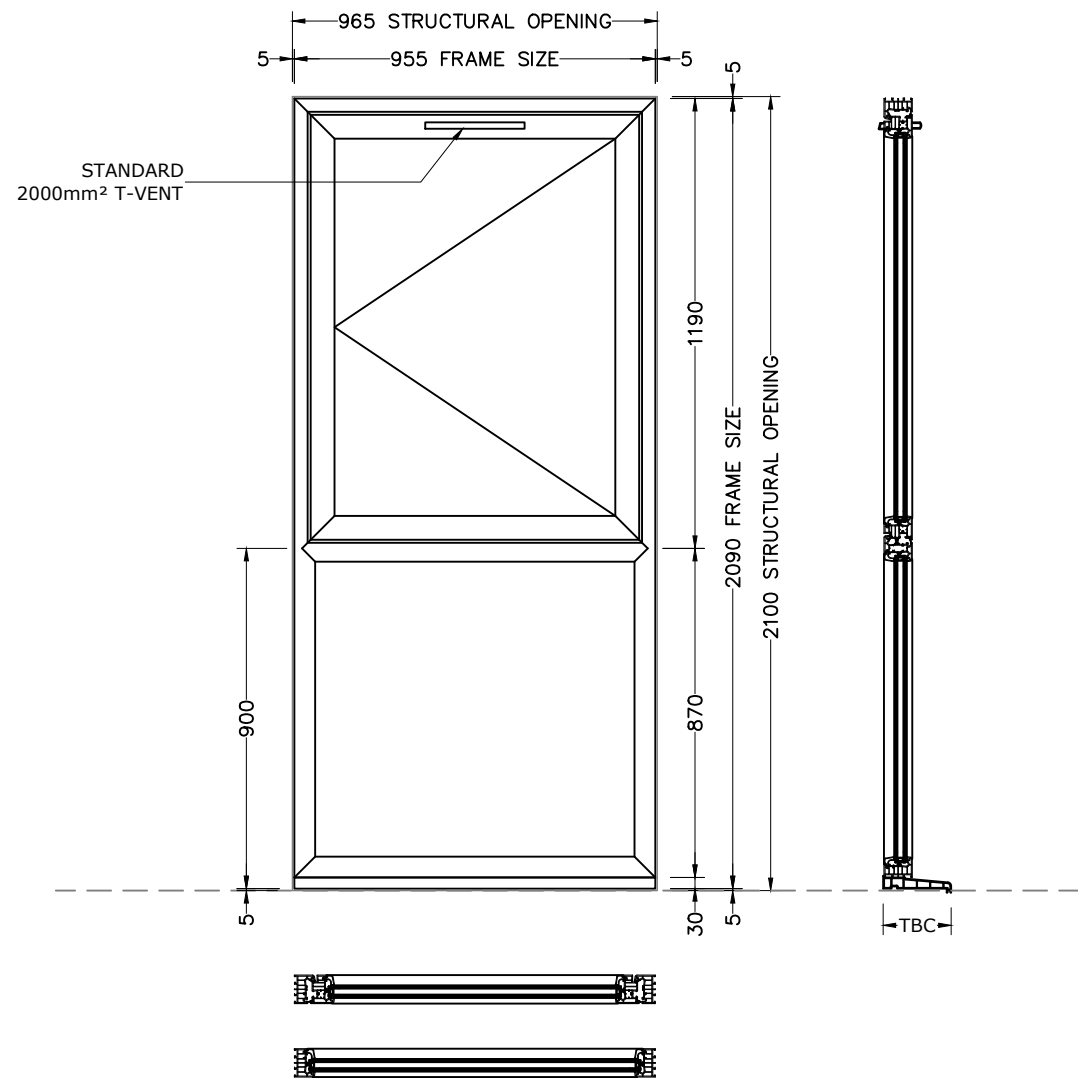

W10 & W11

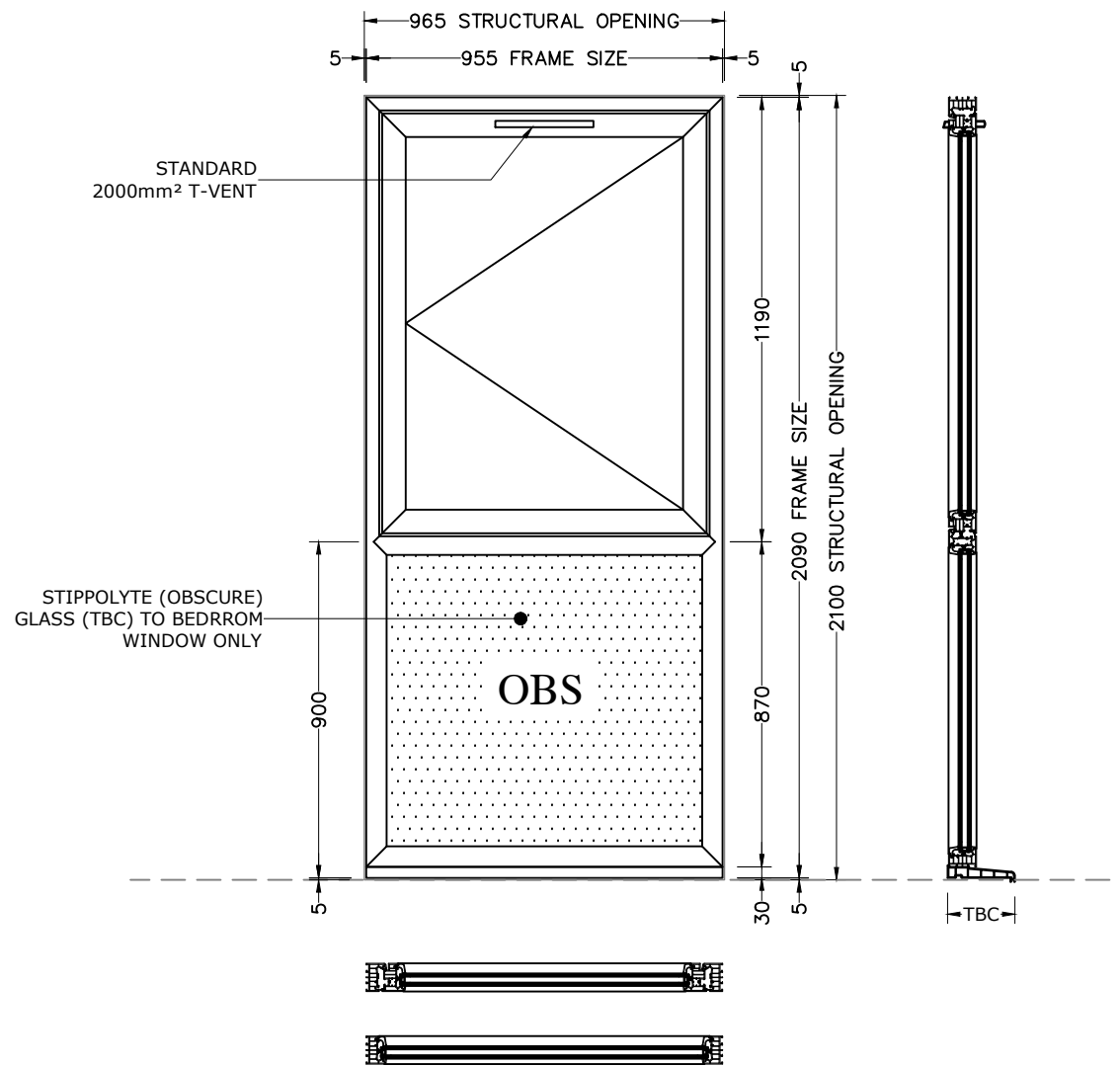

ALL DIMENSIONS ARE IN MILLIMETERS
 UNLESS OTHERWISE SPECIFIED.
 DO NOT SCALE FROM THIS DETAIL.
 IF IN DOUBT ASK.
 THIS DRAWING IS COPYRIGHT.

Architectural Status - Please Advise

A B C

Date _____
 Sign. _____
 Print _____

- A- Proceed no comments
- B- Incorporate comments & proceed
- C- Resubmit for approval

SYSTEM:-

WINDOW - MODUS FLUSH

COLOUR:-

(RAL 7015)Slate Grey Smooth On White

GLASS :-TBC

WINDOW HARDWARE :-

1. Standard Handle
2. Standard Lock
3. Standard Trickle vent
4. Hinge :
 - 1) SBD Hinge All Ground Floor & Accessable Area. (MEGA Hinge Where Applicable)
 - 2) Tried Hinge Above GF Side Hung Window (MEGA Hinge Where Applicable)

CILL :-

TBC

Revisions Format

Ltr	Description	Date
B	Drawing Revised As Per Comments	13.02.19
A	Drawing Revised As Per Comments	23.01.19
Ltr	Description	Date



Unique Window Systems
 87 Parker Drive
 Leicester LE4 0JP
 Tel: 0116 2364656
 Fax: 0116 2364511
 E-Mail: sales@uws.co.uk
 Web site: www.uws.co.uk

Drwg Title	HT SP8		
Job Reference	Heyford Park Phase 8		
Customer	Dorchester Living		
Scale	1:20	Paper	A3
Drawn By	KK	Date	15.01.19
Chkd. Design	SM	Chkd. Contracts	AP
Job No.	H005348		
Drwg. No.	UW-01-SP8	Rev.	B

WINDOW							
NO.	WINDOW REF	ELEVATION	FLOOR	LOCATION	SBD	GLASS	QTY
1	W4	FRONT	FIRST	LANDING	NO	TBC	6
3	W6	REAR	FIRST	LIVING	NO	TBC	6
3	W7	REAR	FIRST	LIVING	NO	TBC	6
4	W10	REAR	SECOND	BED 2	NO	TBC	6
5	W11	REAR	SECOND	BED 3	NO	TBC	6
TOTAL							30