

HOUSE TYPE - SP8  
 PLOT : 365,369,378,381  
 405,408

ALL DIMENSIONS ARE IN MILLIMETERS  
 UNLESS OTHERWISE SPECIFIED.  
 DO NOT SCALE FROM THIS DETAIL.  
 IF IN DOUBT ASK.  
 THIS DRAWING IS COPYRIGHT.

Architectural Status - Please Advise

A  B  C

Date \_\_\_\_\_

Sign. \_\_\_\_\_

Print \_\_\_\_\_

A- Proceed no comments

B- Incorporate comments & proceed

C- Resubmit for approval

**SYSTEM:-**

WINDOW - MODUS FLUSH

**COLOUR:-**

(RAL 7015)Slate Grey Smooth On White

**GLASS :-TBC**

**WINDOW HARDWARE :-**

1. Standard Handle
2. Standard Lock
3. Standard Trickle vent
4. Hinge :
  - 1) SBD Hinge All Ground Floor & Accessable Area. (MEGA Hinge Where Applicable)
  - 2) Tried Hinge Above GF Side Hung Window (MEGA Hinge Where Applicable)

**CILL :-**

TBC

Only plot No. 408

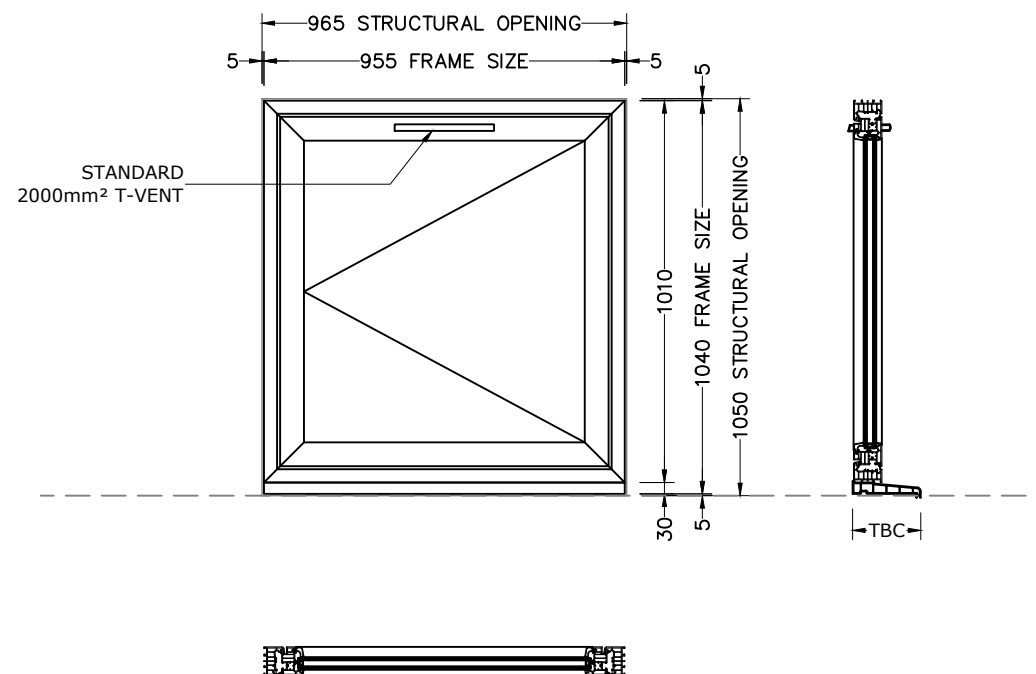

Revisions Format

Ltr	Description	Date

Ltr	Description	Date



Unique Window Systems  
 87 Parker Drive  
 Leicester LE4 0JP  
 Tel: 0116 2364656  
 Fax: 0116 2364511  
 E-Mail: sales@uws.co.uk  
 Web site: www.uws.co.uk

Drwg Title | HT SP8

Job Reference | Heyford Park Phase 8

Customer | Dorchester Living

Scale | 1:20 | Paper | A3

Drawn By | KK | Date | 15.01.19

Chkd. Design | SM | Chkd. Contracts | AP

Job No. | H005348

Drwg. No. | UW-06-SP8 | Rev. | ----

WINDOW							
NO.	WINDOW REF	ELEVATION	FLOOR	LOCATION	SBD	GLASS	QTY
1	W13	SIDE	GROUND	FAMILY	NO	TBC	1
2	W18	SIDE	FIRST	LIVING	NO	TBC	1
TOTAL							2