

HOUSE TYPE - SP8
 PLOT : 365,369,378,381
 405,408

ALL DIMENSIONS ARE IN MILLIMETERS
 UNLESS OTHERWISE SPECIFIED.
 DO NOT SCALE FROM THIS DETAIL.
 IF IN DOUBT ASK.
 THIS DRAWING IS COPYRIGHT.

Architectural Status - Please Advise

A B C

Date _____
 Sign. _____
 Print _____

A- Proceed no comments
 B- Incorporate comments & proceed
 C- Resubmit for approval

SYSTEM:-

WINDOW - MODUS FLUSH

COLOUR:-

(RAL 7015)Slate Grey Smooth On White

GLASS :-TBC

WINDOW HARDWARE :-

1. Standard Handle
2. Standard Lock
3. Standard Trickle vent
4. Hinge :
 - 1) SBD Hinge All Ground Floor & Accessable Area. (MEGA Hinge Where Applicable)
 - 2) Tried Hinge Above GF Side Window (MEGA Hinge Where Applicable)

CILL :-

TBC

Revisions Format

Ltr	Description	Date
A	Drawing Revised As Per Comments	23.01.19
Ltr	Description	Date



Unique Window Systems
 87 Parker Drive
 Leicester LE4 0JP
 Tel: 0116 2364656
 Fax: 0116 2364511
 E-Mail: sales@uws.co.uk
 Web site: www.uws.co.uk

Drwg Title	HT SP8	
Job Reference	Heyford Park Phase 8	
Customer	Dorchester Living	
Scale	1:20	Paper A3
Drawn By	KK	Date 15.01.19
Chkd. Design	SM	Chkd. Contracts AP
Job No.	H005348	
Drwg. No.	UW-07-SP8	Rev. A

W15
 Only plot No. 365, 405 & 381

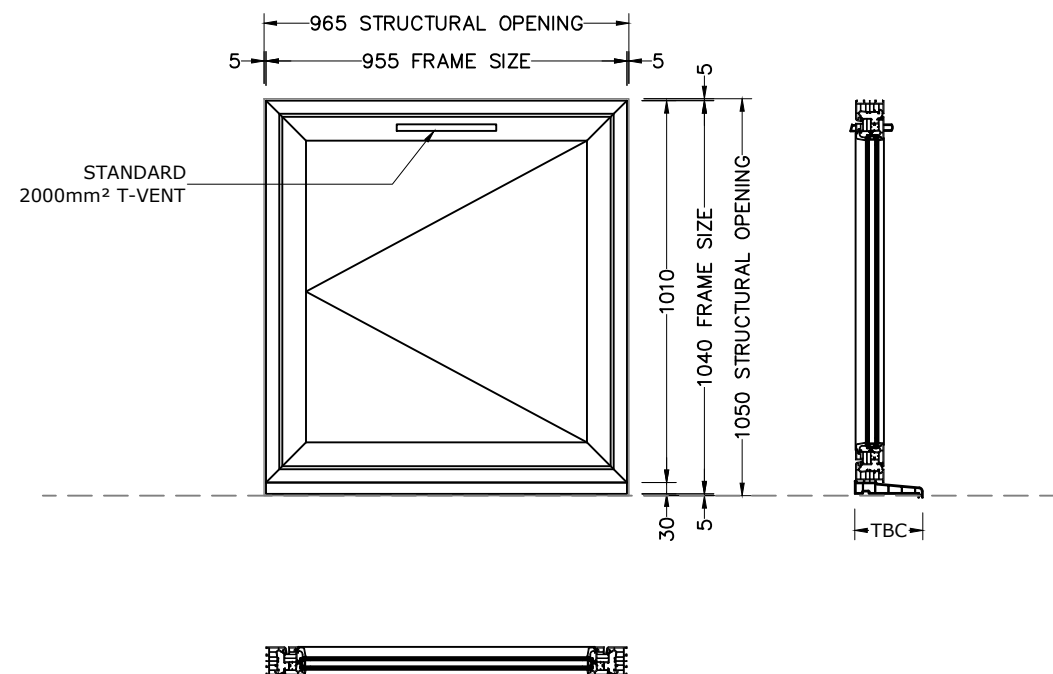

W21
 Only plot No. 365, 405 & 381

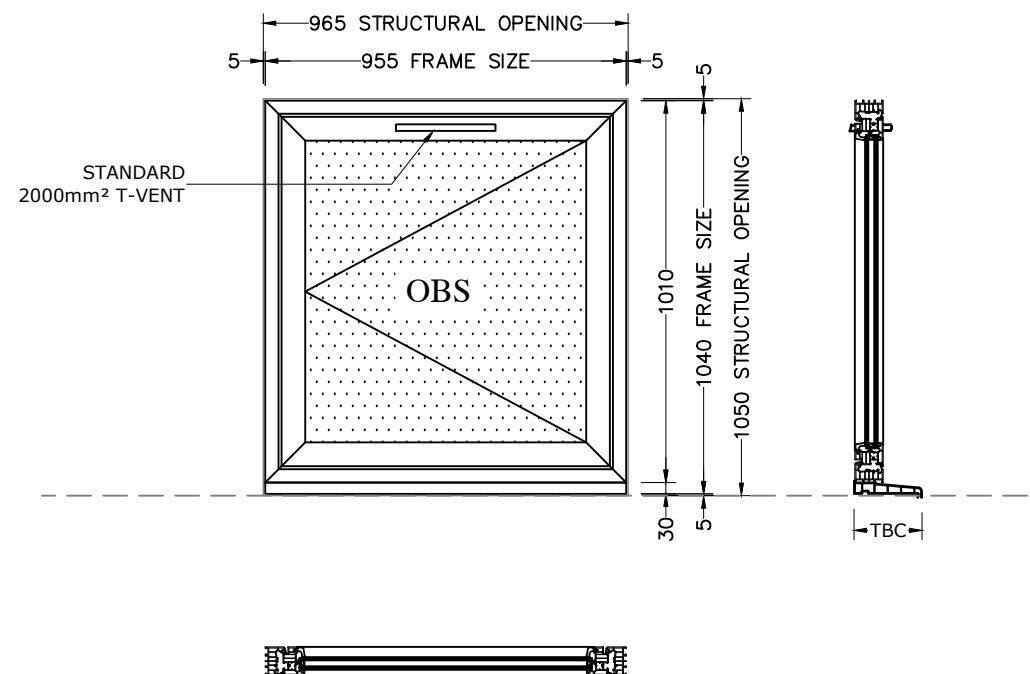

WINDOW							
NO.	WINDOW REF	ELEVATION	FLOOR	LOCATION	SBD	GLASS	QTY
1	W15	SIDE	FIRST	DINING	NO	TBC	3
2	W21	SIDE	SECOND	BATH	NO	TBC	3
TOTAL							6