

HOUSE TYPE - SP8
 PLOT : 365,369,378,381
 405,408

ALL DIMENSIONS ARE IN MILLIMETERS
 UNLESS OTHERWISE SPECIFIED.
 DO NOT SCALE FROM THIS DETAIL.
 IF IN DOUBT ASK.
 THIS DRAWING IS COPYRIGHT.

Architectural Status - Please Advise

A B C

Date _____

Sign. _____

Print _____

A- Proceed no comments

B- Incorporate comments & proceed

C- Resubmit for approval

SYSTEM:-

WINDOW - MODUS FLUSH

COLOUR:-

(RAL 7015)Slate Grey Smooth On White

GLASS :-TBC

WINDOW HARDWARE :-

1. Standard Handle
2. Standard Lock
3. Standard Trickle vent
4. Hinge :
 - 1) SBD Hinge All Ground Floor & Accessible Area. (MEGA Hinge Where Applicable)
 - 2) Tried Hinge Above GF Side Hung Window (MEGA Hinge Where Applicable)

CILL :-

TBC

Only plot No. 381 & 405

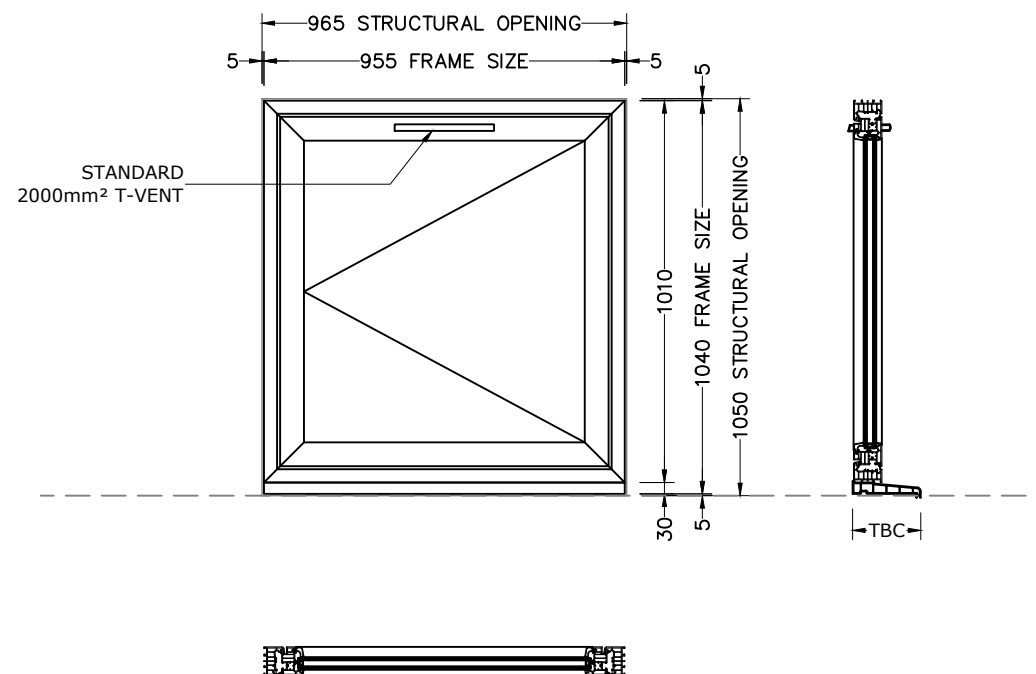

Revisions Format

Ltr	Description	Date

Ltr	Description	Date



Unique Window Systems
 87 Parker Drive
 Leicester LE4 0JP
 Tel: 0116 2364656
 Fax: 0116 2364511
 E-Mail: sales@uws.co.uk
 Web site: www.uws.co.uk

Drwg Title | HT SP8

Job Reference | Heyford Park Phase 8

Customer | Dorchester Living

Scale | 1:20 | Paper | A3

Drawn By | KK | Date | 15.01.19

Chkd. Design | SM | Chkd. Contracts | AP

Job No. | H005348

Drwg. No. | UW-08-SP8 | Rev. | ----

WINDOW							
NO.	WINDOW REF	ELEVATION	FLOOR	LOCATION	SBD	GLASS	QTY
1	W16	SIDE	FIRST	KITCHEN	NO	TBC	2
2	W22	SIDE	SECOND	BED 1	NO	TBC	2
TOTAL							4