

HOUSE TYPE - SP8  
 PLOT : 365,369,378,381  
 405,408

ALL DIMENSIONS ARE IN MILLIMETERS  
 UNLESS OTHERWISE SPECIFIED.  
 DO NOT SCALE FROM THIS DETAIL.  
 IF IN DOUBT ASK.  
 THIS DRAWING IS COPYRIGHT.

Architectural Status - Please Advise

A  B  C

Date \_\_\_\_\_  
 Sign. \_\_\_\_\_  
 Print \_\_\_\_\_

A- Proceed no comments  
 B- Incorporate comments & proceed  
 C- Resubmit for approval

**SYSTEM:-**

WINDOW - MODUS FLUSH

**COLOUR:-**

(RAL 7015)Slate Grey Smooth On White

**GLASS :-TBC**

**WINDOW HARDWARE :-**

1. Standard Handle
2. Standard Lock
3. Standard Trickle vent
4. Hinge :
  - 1) SBD Hinge All Ground Floor & Accessable Area. (MEGA Hinge Where Applicable)
  - 2) Tried Hinge Above GF Side Hung Window (MEGA Hinge Where Applicable)

**CILL :-**

TBC

Revisions Format

Ltr	Description	Date
A	Drawing Revised As Per Comments	13.02.19
Ltr	Description	Date



Unique Window Systems  
 87 Parker Drive  
 Leicester LE4 0JP  
 Tel: 0116 2364656  
 Fax: 0116 2364511  
 E-Mail: sales@uws.co.uk  
 Web site: www.uws.co.uk

Drwg Title	HT SP8	
Job Reference	Heyford Park Phase 8	
Customer	Dorchester Living	
Scale	1:20	Paper A3
Drawn By	KK	Date 15.01.19
Chkd. Design	SM	Chkd. Contracts AP
Job No.	H005348	
Drwg. No.	UW-10-SP8	Rev. A

W19  
 Only plot No. 369 & 408

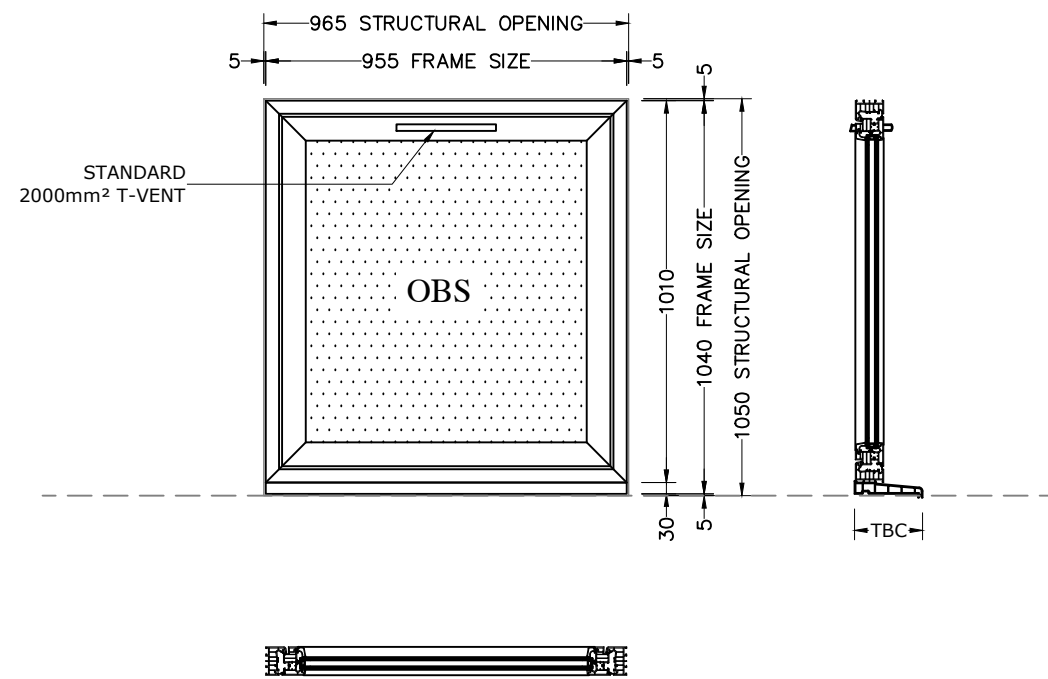

W24  
 Only plot No. 369 & 408

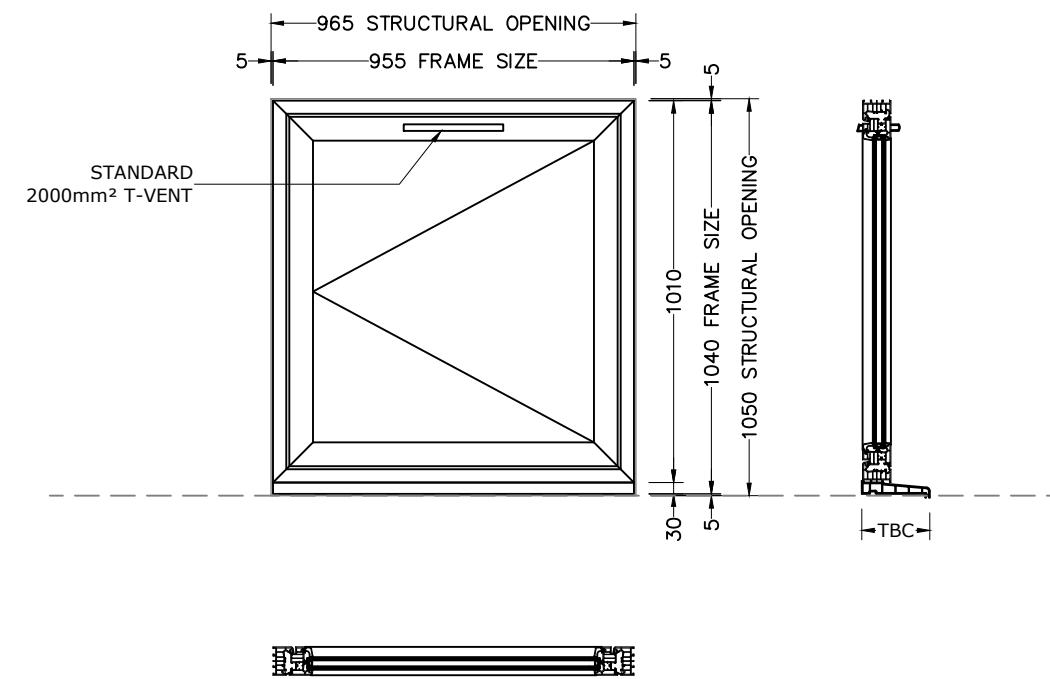

WINDOW							
NO.	WINDOW REF	ELEVATION	FLOOR	LOCATION	SBD	GLASS	QTY
1	W19	SIDE	FIRST	LANDING	NO	TBC	2
2	W24	SIDE	SECOND	LANDING	NO	TBC	2
TOTAL							4