

- CONTRACTORS MUST CHECK ALL DIMENSIONS ON SITE. ONLY FIGURED DIMENSIONS ARE TO BE WORKED FROM. DISCREPANCIES MUST BE REPORTED TO THE ARCHITECT OR ENGINEER BEFORE PROCEEDING. © THIS DRAWING IS COPYRIGHT.
- REPRODUCED FROM OS SITEMAP BY PERMISSION OF ORDNANCE SURVEY ON BEHALF OF THE CONTROLLER OF HER MAJESTY'S STATIONERY OFFICE. © CROWN COPYRIGHT 2008. ALL RIGHTS RESERVED. LICENCE NUMBER 100007125.
- UNTIL TECHNICAL APPROVAL HAS BEEN OBTAINED FROM THE RELEVANT AUTHORITIES, ALL DRAWINGS ARE ISSUED AS PRELIMINARY AND NOT FOR CONSTRUCTION. SHOULD THE CONTRACTOR COMMENCE SITE WORK PRIOR TO APPROVAL BEING GIVEN IT IS ENTIRELY AT HIS OWN RISK.

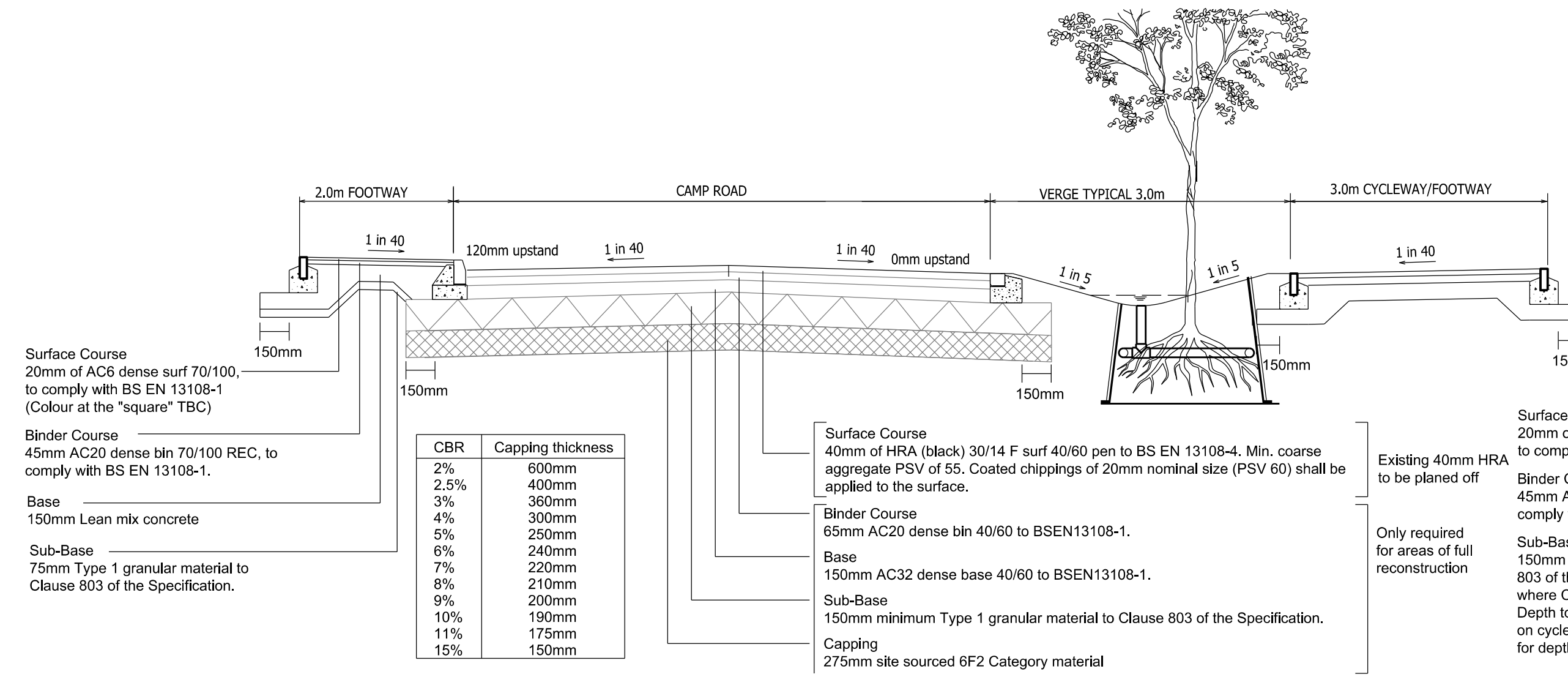

TYPICAL CAMP ROAD FOOTWAY CONSTRUCTION ADJACENT TO CARRIAGEWAY

TYPICAL CAMP ROAD BITUMINOUS CONSTRUCTION DETAIL

TYPICAL CAMP ROAD FOOTWAY CONSTRUCTION NOT ADJUTING TO CARRIAGEWAY

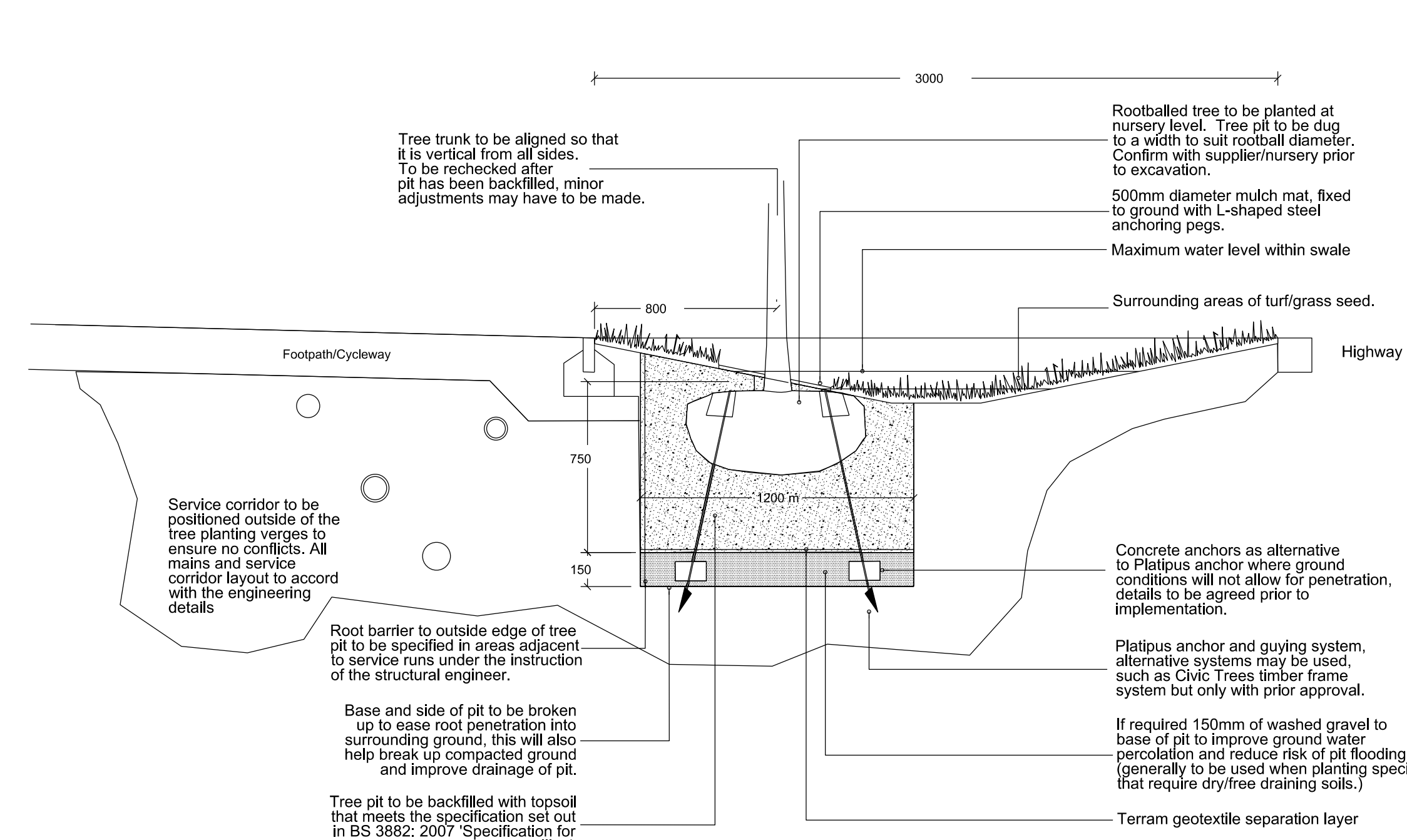

TYPICAL SECTION THROUGH SWALE FEATURE

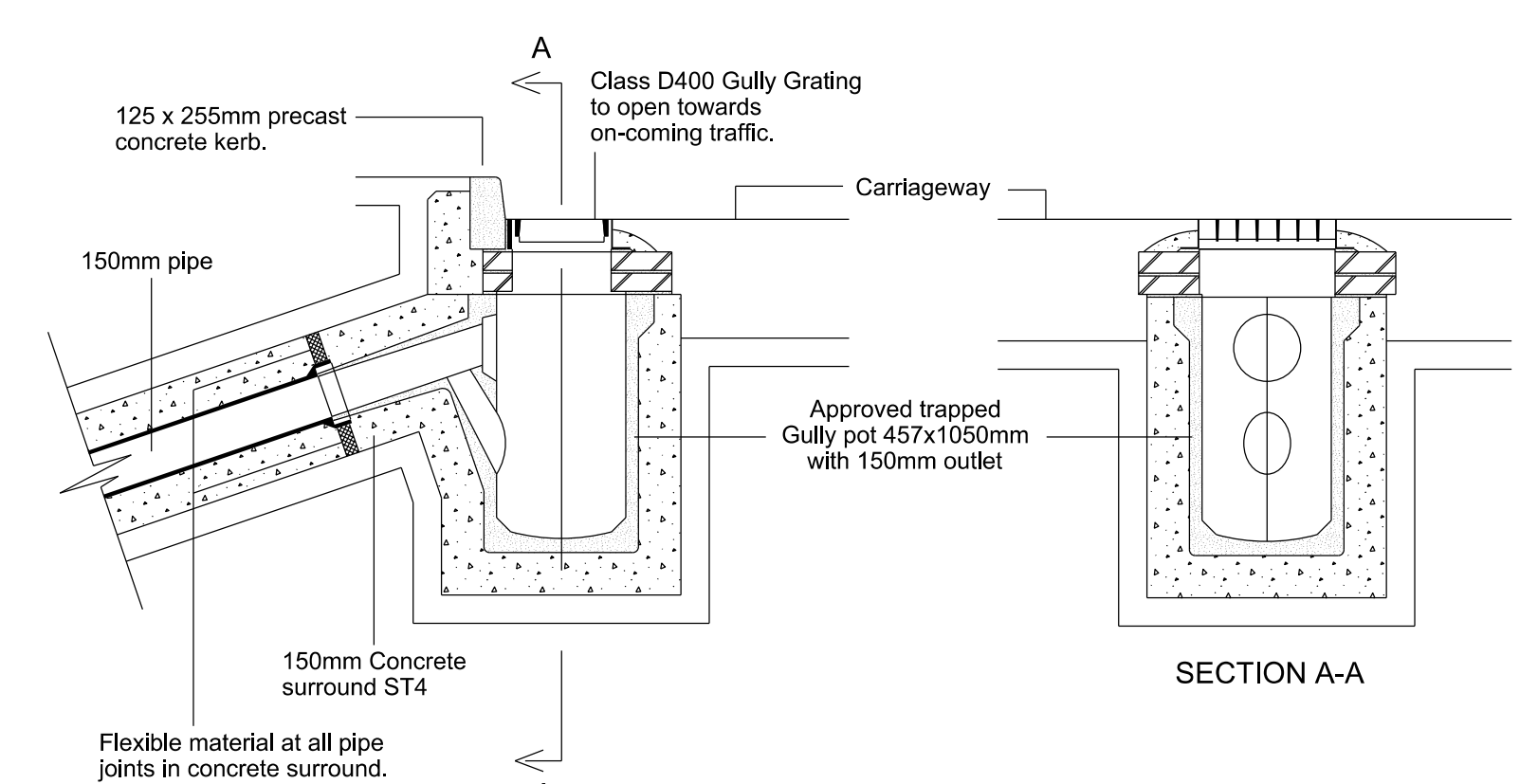

All gully pots to BS 5911 Pt 2. All grates and frames to comply with BS EN 124 150mm in width. They shall be straight bar pattern. Gully grating and frames in access ways to be 325mm in width. The grating and frames shall be bedded using Designation (i) mortar and set on minimum two courses and a maximum of 4 courses of Class B engineering bricks so that the top of the frames is below the finished channel level within the tolerance of -5mm to -10mm where measured adjacent to the kerfing. The gully frames shall be set to the carriageway gradient. Where the carriageway is constructed to the base course level for use as a builders road, the gully frames should initially be set to base course level.

Gully pots shall be 450mm internal diameter by 1050mm deep with 150mm diameter trapped outlet and rodding eye with C.1 stopper and chain. They shall be of an approved manufacture in precast concrete to BS 5911, set glazed ware or Clayware to BS 69 and shall be laid with 150mm thickness of ST4 concrete. Connections to the sewer shall be by 100mm diameter clay or concrete pipes bedded on 150mm concrete and surrounded with ST4 concrete to a thickness of 150mm when the cover to the pipes is less than 1.2m.

Gullies should preferably connect directly into manholes, but, if this is not appropriate, they shall be connected to the main pipe by means of 45 degree oblique angled junctions, and surrounded by ST4 concrete to a thickness of 150mm. Gully connections shall not be longer than 20m.

Class D400 gully grating and frame to open towards on-coming vehicles and be single piece, hinged, non-rop, type to BS EN 124 (size 370 x 450mm) minimum waterway area 1000sqcm with straight bar pattern.

GULLY DETAIL

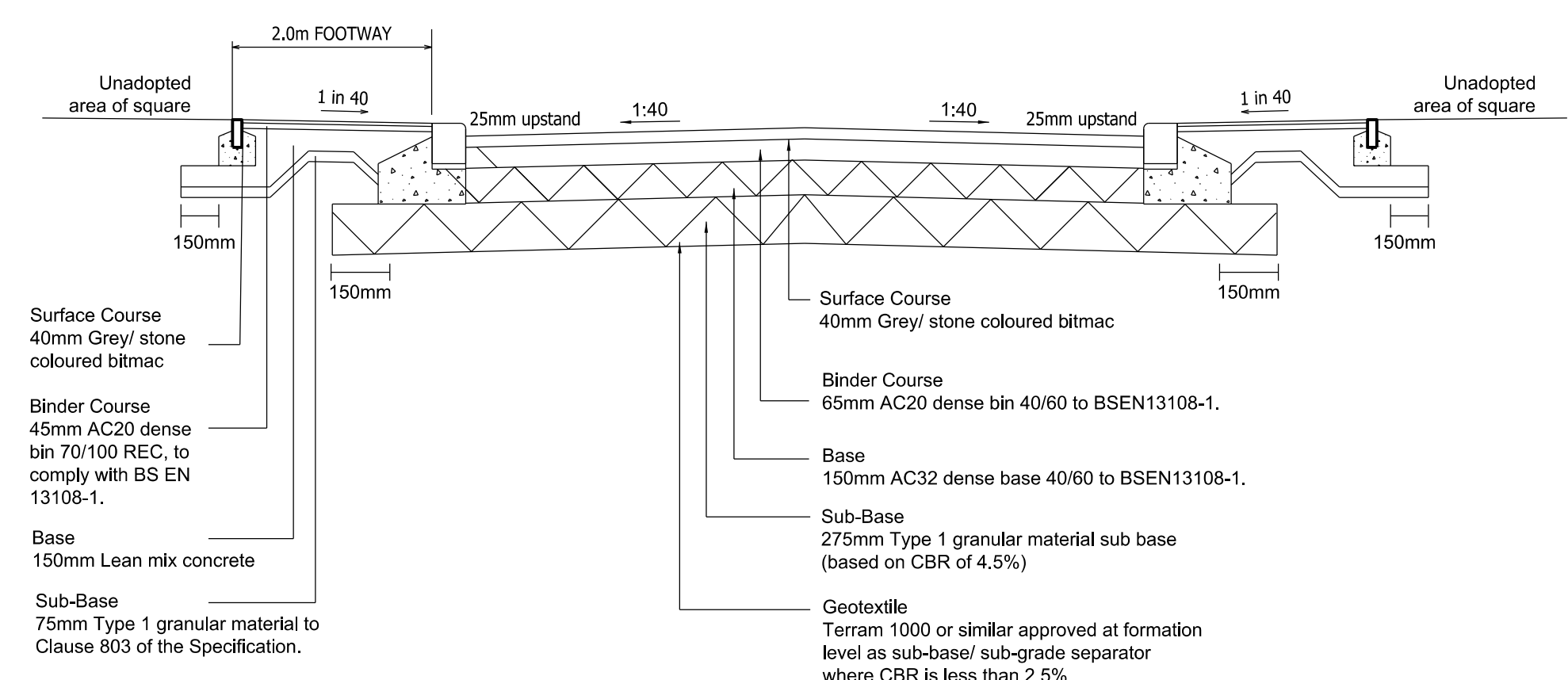

TYPICAL CAMP ROAD ADOPTABLE 'VILLAGE SQUARE' RAISED TABLE

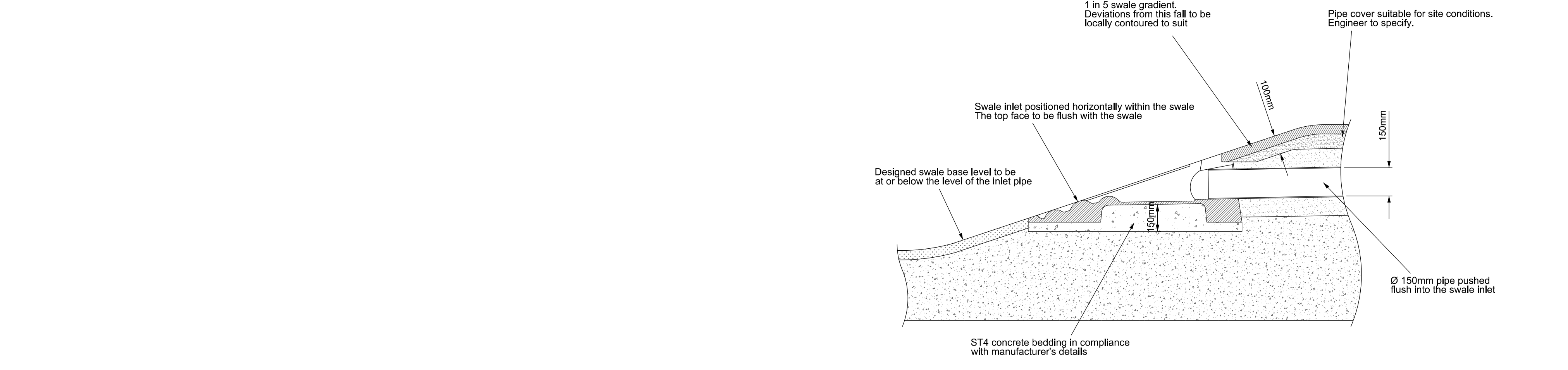

ACO HEADWALL INLET TO SWALE

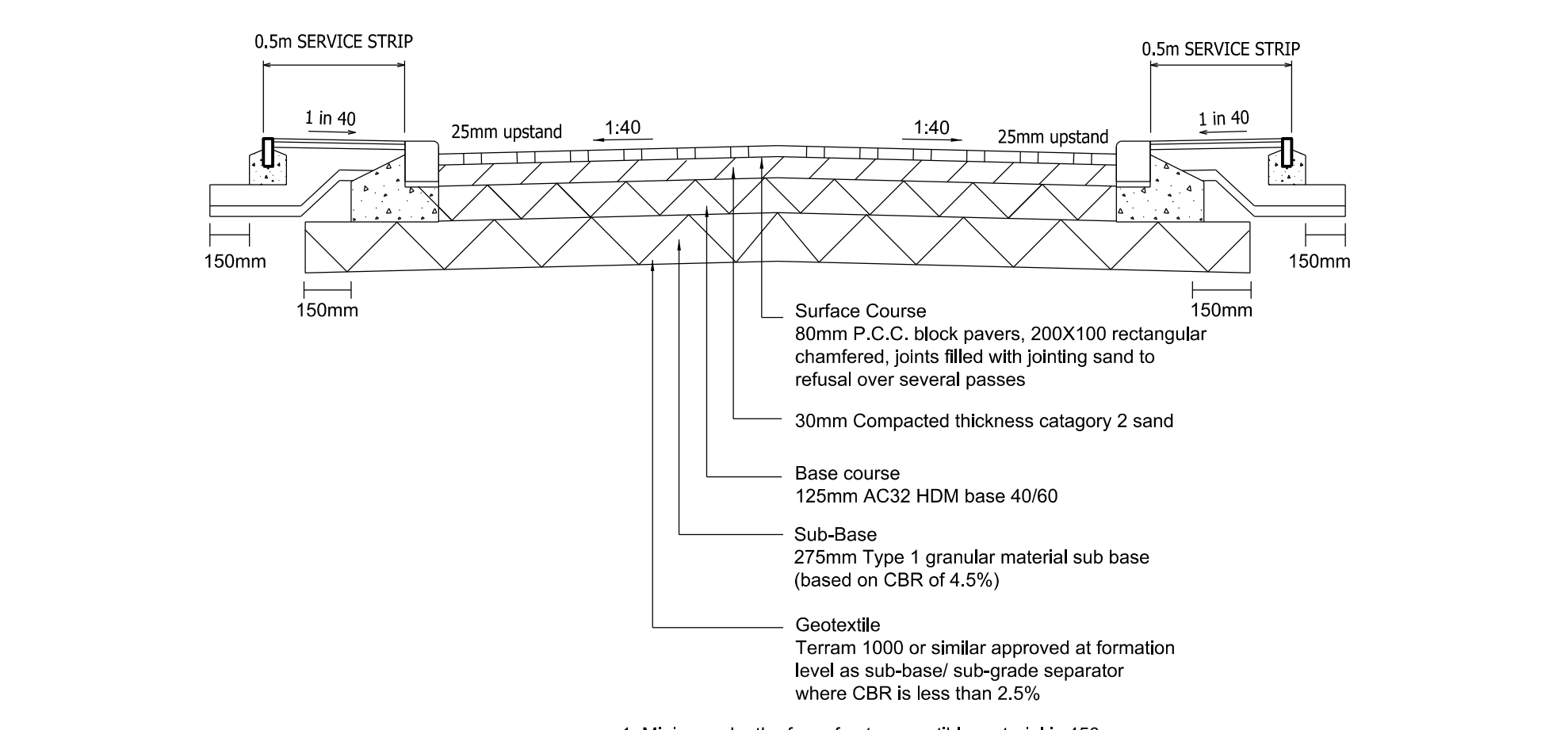

TYPICAL CAMP ROAD ADOPTABLE BLOCK PAVING RAISED TABLE

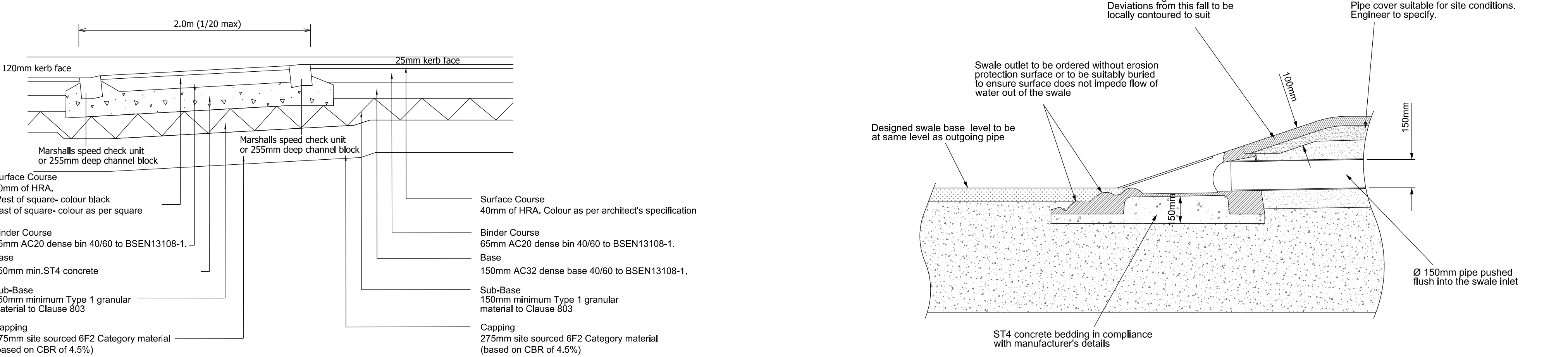

ACO HEADWALL OUTLET FROM SWALE

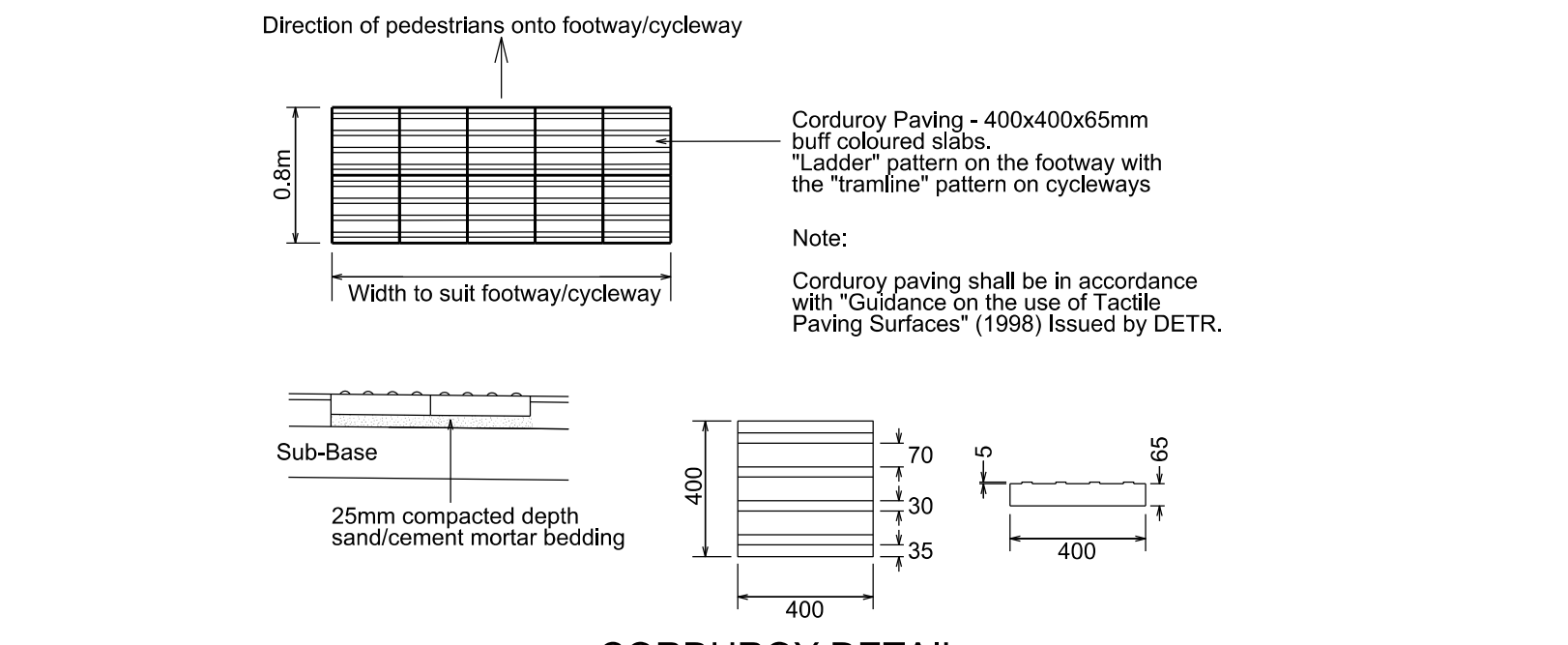

CORDUROU DETAIL

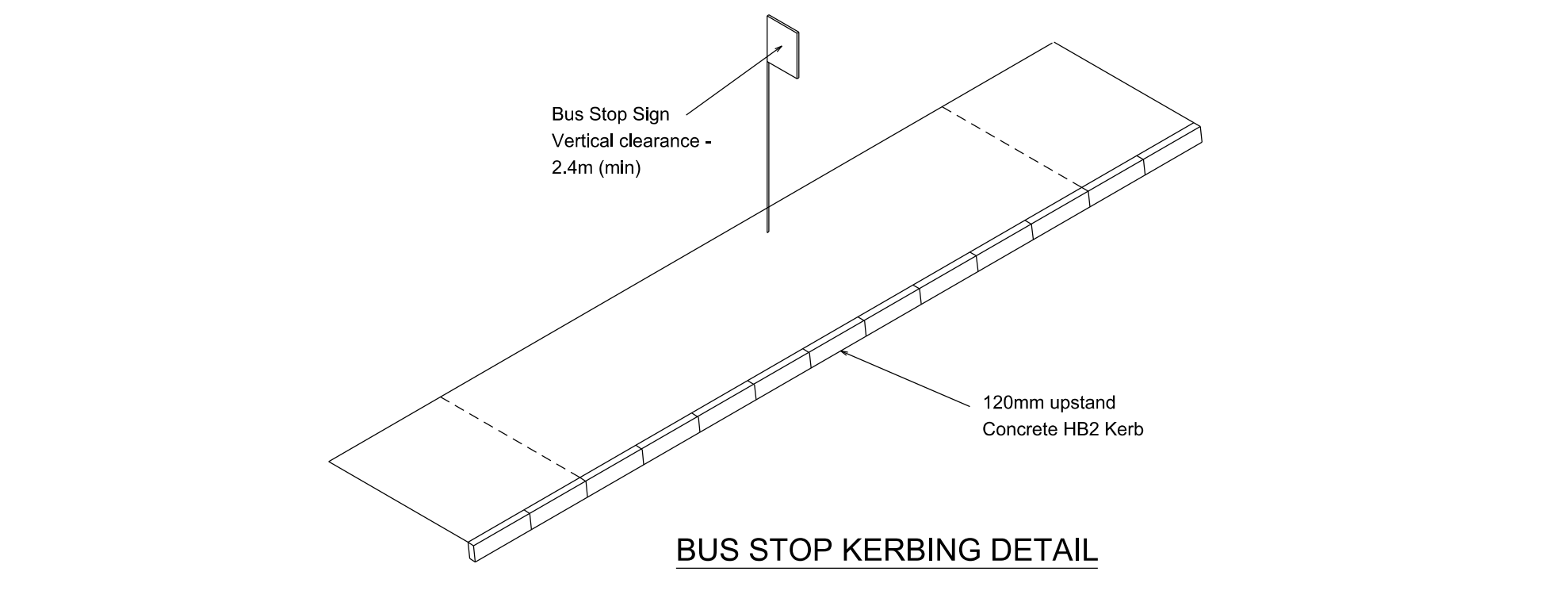

BUS STOP KERBING DETAIL

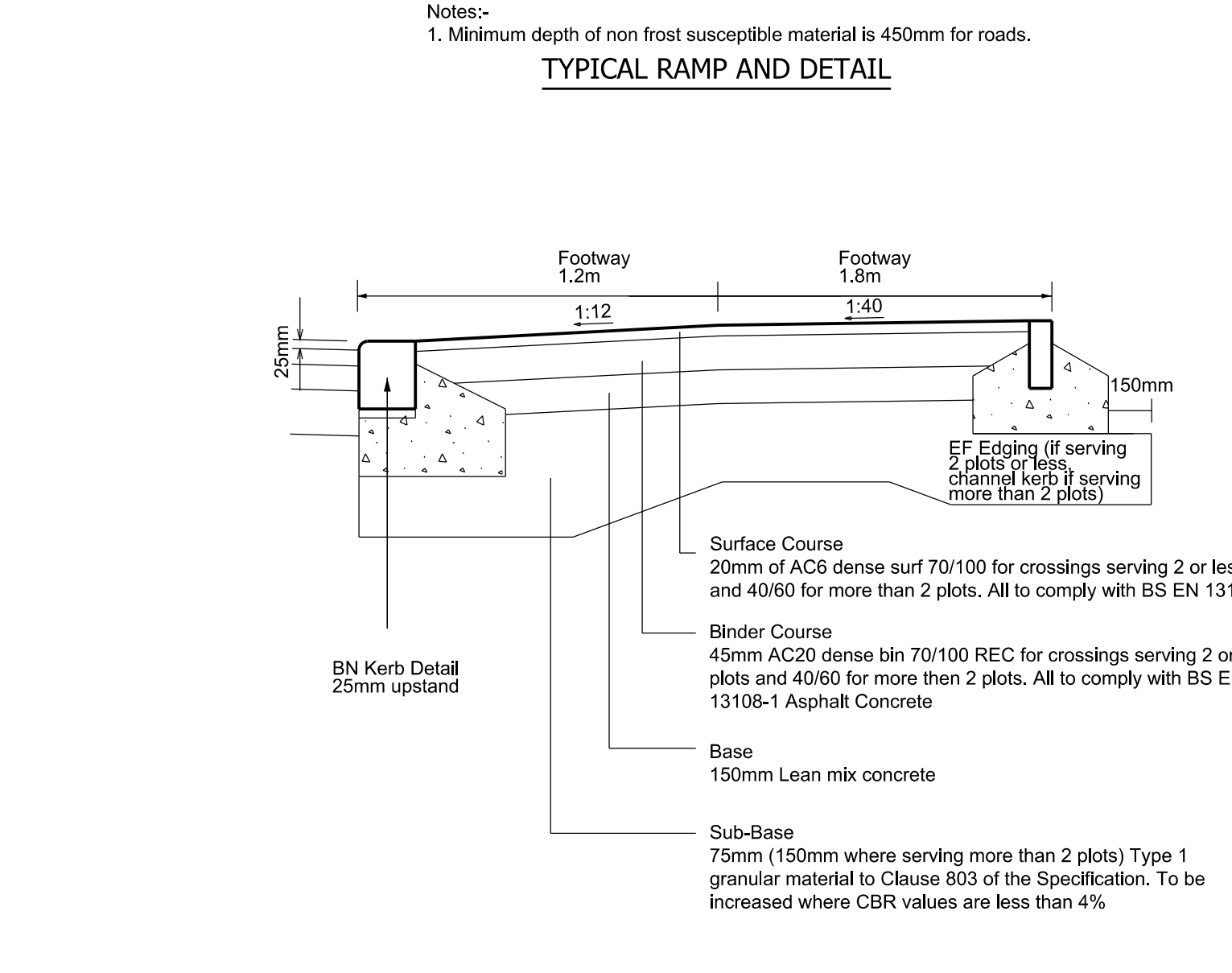

CAMP ROAD VEHICULAR CROSSING DETAIL WITHOUT VERGE

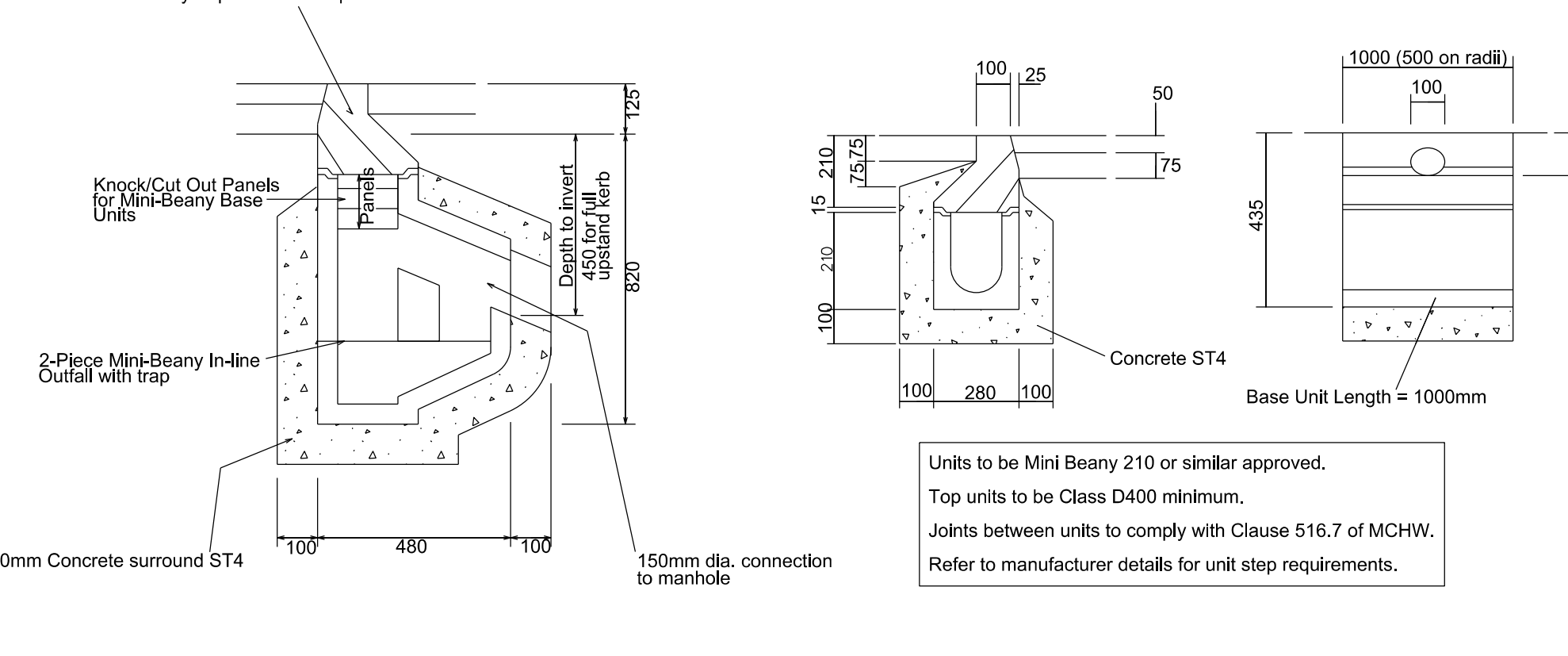

LINEAR KERB DRAINAGE CHANNEL

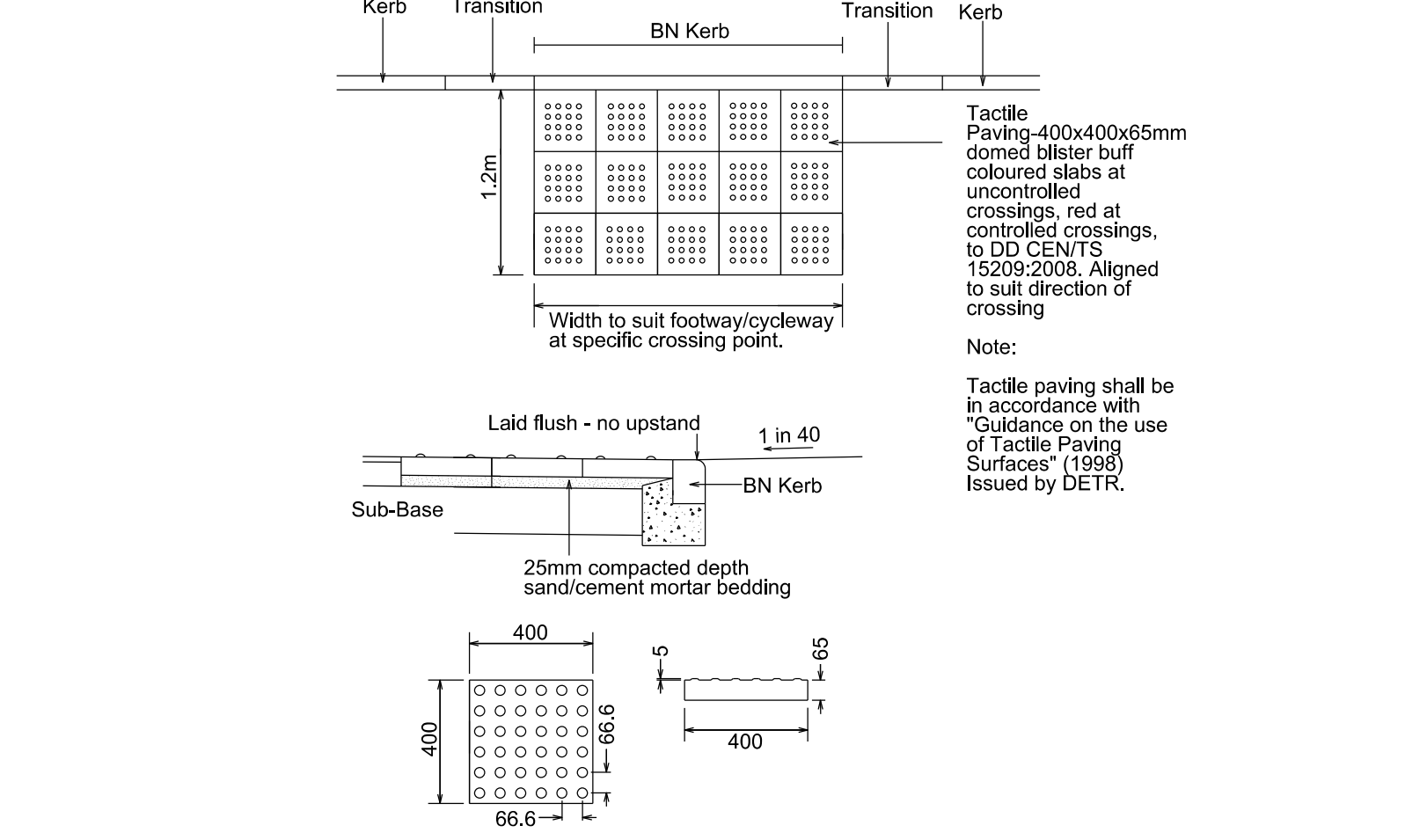

TACTILE CROSSING DETAIL HSD-1100-102

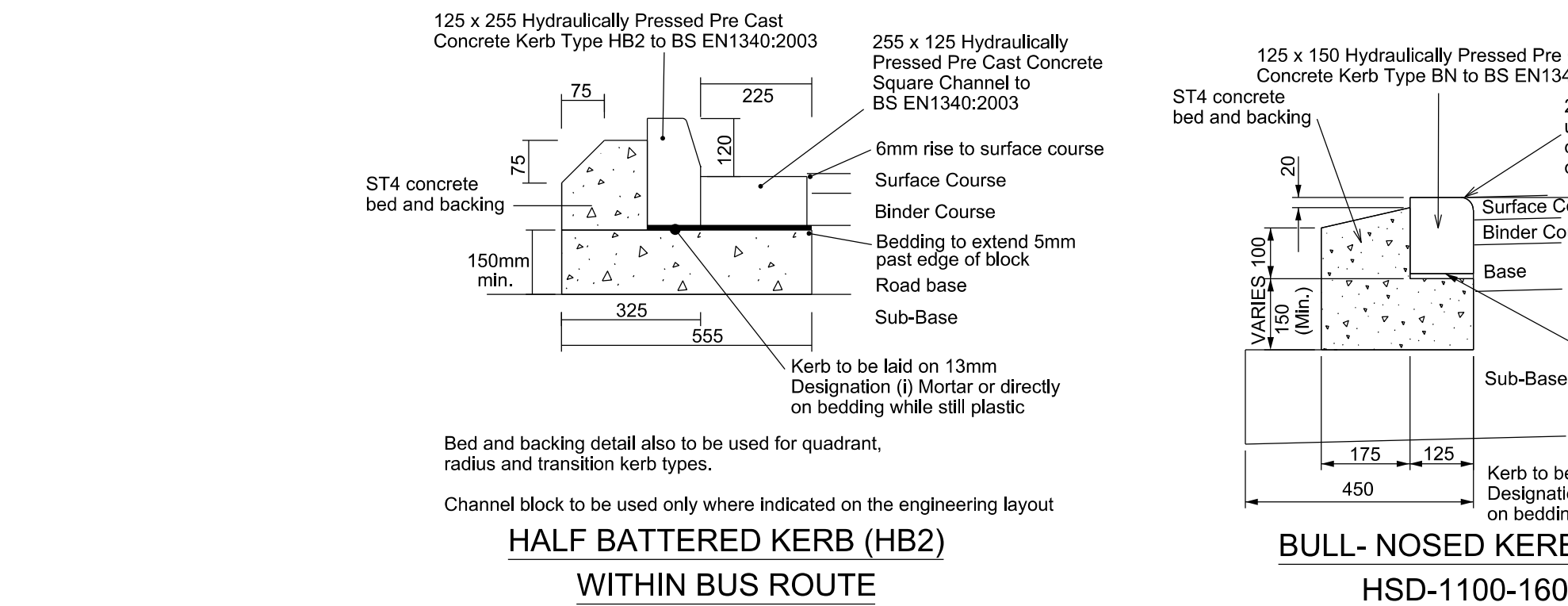

HALF BATTERED KERB (HB2) WITHIN BUS ROUTE

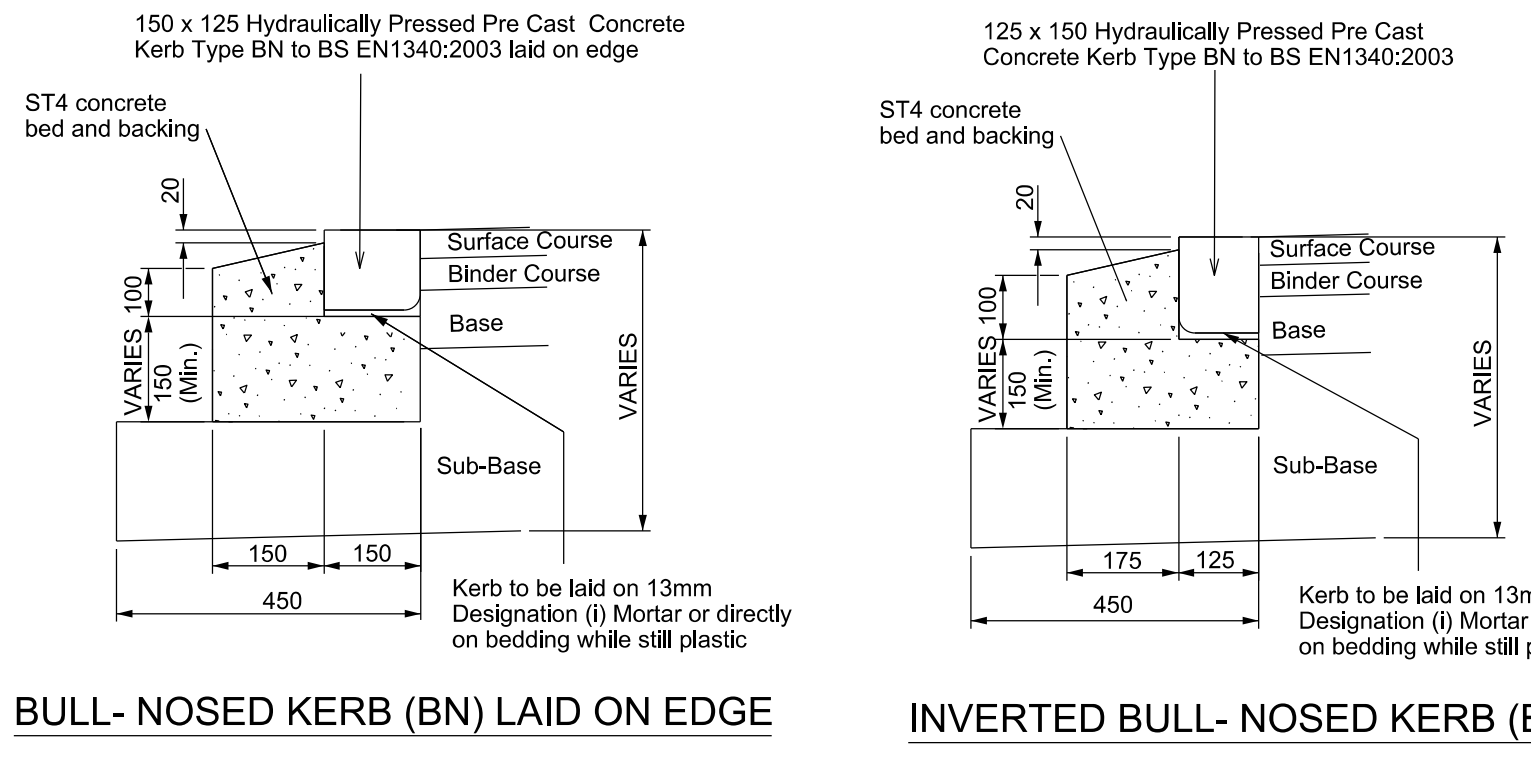

BULL-NOSED KERB (BN) HSD-1100-160

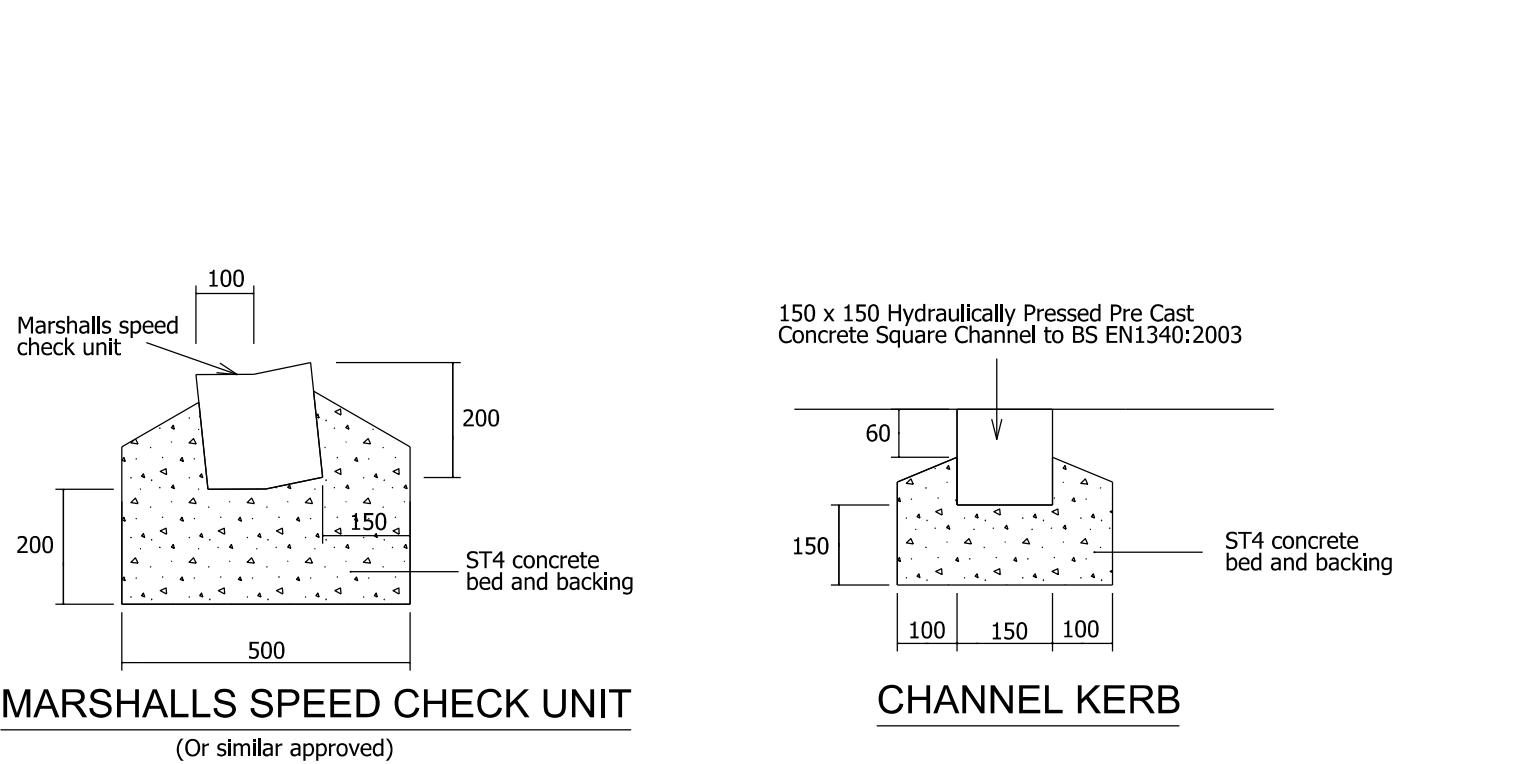

MARSHALLS SPEED CHECK UNIT (Or similar approved)

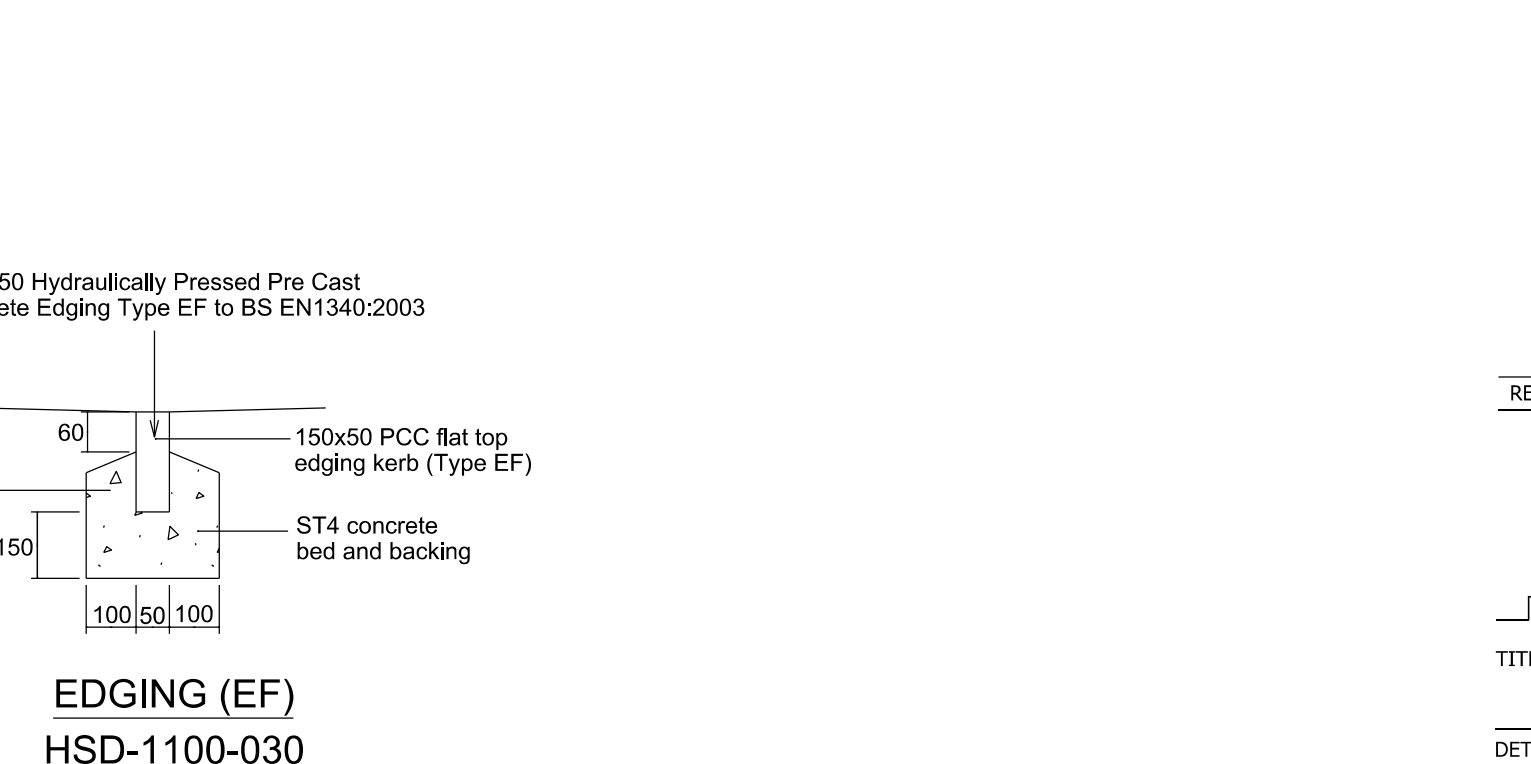

CHANNEL KERB

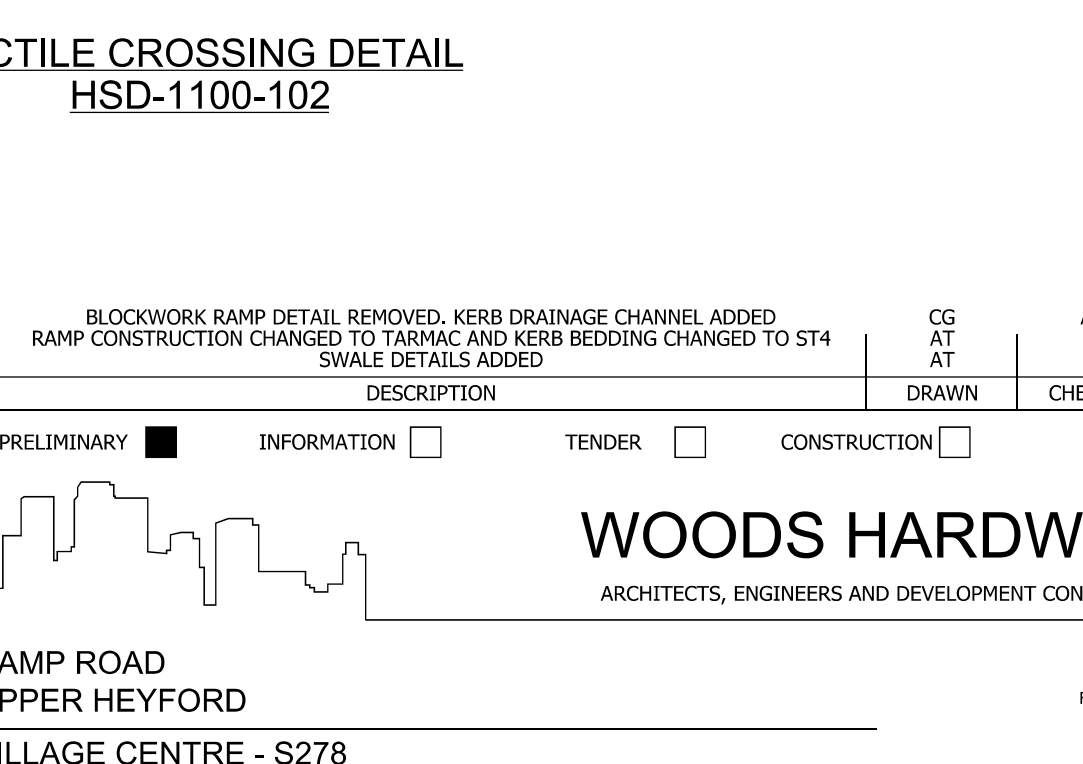

EDGING (EF) HSD-1100-030

WOODS HARDWICK ARCHITECTS, ENGINEERS AND DEVELOPMENT CONSULTANTS

151-160 COLINDALE ROAD, UPPER HEYFORD, BIRMINGHAM, B24 9JF. T: +44 (0)121 268824. F: +44 (0)121 268825. WWW.WOODSHARDWICK.COM

TITLE: CAMP ROAD UPPER HEYFORD
 DETAILS: VILLAGE CENTRE - S278
 TYPICAL CONSTRUCTION DETAILS

SCALE: NTS @ A0 DATE: AUGUST 2016 DRAWN: AT CHK: JF

REVISION: PRELIMINARY INFORMATION TENDER CONSTRUCTION AS BUILT

DATE: 30.05.17
 DATE: 03.08.17
 DATE: 06.08.17

FILE: HEYF5/223 C