



# Plot SGR 1, Bicester

## Flood Risk Assessment

### Section 2 of 2

On behalf of  
**SGR (Bicester 1) Limited**

Project Ref: 41436/2002 | Rev: 01 | Date: March 2018

---

Office Address: Caversham Bridge House, Waterman Place, Reading, Berkshire RG1 8DN  
T: +44 (0)118 950 0761 F: +44 (0)118 959 7498 E: [reading@peterbrett.com](mailto:reading@peterbrett.com)



# Appendix C Existing Greenfield Runoff Rates

## 4.1 Greenfield estimation of peak flow rate of runoff

The aim of this first section is to determine the peak discharge rate of the greenfield site runoff for 1, 30 and 100 year return period events.

### Site characteristics

1. Hydrological Region (1 – 10) (R) 6 UK is divided up into 10 hydrological regions reflecting the different flood frequency growth curves. (Appendix 1, Figure A1.1)
  
2. (SOIL) type (1 – 5) (S) 1 Refer to Wallingford Procedure WRAP map or FSR maps (Appendix 1, Figure A5.1)
  
3. Development size (A) 1 ha The size of the gross development excluding large parkland areas being allocated as public open space which remain unmodified.
  
4. Area (A) 1 ha Excluding public open space not modified by the proposed development
  
5. Annual Rainfall (SAAR) 635 mm SAAR – use either SAAR from FSR or AAR from FEH (Appendix 1, Figure A4.1)
  
6. Soil runoff coefficient (SPR) 0.10 SPR value for SOIL – this is not the FSR index class value for SOIL (1 to 5), but its corresponding runoff coefficient (SPR) as follows:

SOIL	1	2	3	4	5
SPR	0.10	0.30	0.37	0.47	0.53

Also see note 1 below.

7. Development mean annual peak flow

$$Q_{BAR} = 1.08 \left(\frac{A}{100}\right)^{0.89} \cdot SAAR^{1.17} \cdot SPR^{2.17} \quad (Q_{BAR})$$

7.49 l/s

$(Q_{BAR} = Q_{BAR50 \text{ hr}} \times (A/50))$

For development sites of 50 ha or less, use 50 ha when applying the formula. Subsequently factor the resulting value by the ratio of the site area to 50 ha. (i.e. if the site is 10 ha divide the answer by 5)  
For using the equation from the Statistical FEH see note 4

8. Mean annual peak flow per unit area  $(Q_{BAR}/A)$

0.15 l/s/ha

For SOIL type 1 and occasionally type 2  $Q_{BAR}/A$  will generally have a value less than 1. If so use 1 l/s/ha (see note 2)

9. Minimum limit of discharge  $(Q_{throttle})$

5 l/s

Minimum discharge (see note 3)

9.1 1:100 year flow rate per unit area  $(Q_{throttle}/A)$

5 l/s/ha

9.2 Equivalent mean annual peak flow per unit area

1.43 l/s/ha

Use this value as  $(Q_{BAR}/A)$  if it is greater than item 8.

10. 1yr, 30yr and 100yr peak discharge rate of runoff per unit area

10.1  $Q_{BAR}/A \times 0.85$   $Q_{1yr}$  1.22 l/s/ha

Use the larger of the 2 values of item 8 and 9.2 for calculating 10.1 to 10.3

10.2  $Q_{BAR}/A \times GC_{30}$   $Q_{30yr}$  3.29 l/s/ha

$GC_{30}$  and  $GC_{100}$  are the growth curve ratios  $Q/\bar{Q}$  for the 30 year and 100 year events for the relevant hydrological region.

10.3  $Q_{BAR}/A \times GC_{100}$   $Q_{100yr}$  4.56 l/s/ha

The 30 and 100 year factors are found from Appendix 1, Figure A1.2 from FSSR 14.

**Note 1** HOST classes for soil also have SPR values. Although derived a little differently, these values can also be used – read chapter 6 (IH Report 126 – Hydrology of Soil Types). As the ranges used in FSR soil types are very coarse it is preferable to use the HOST categories, but values should be limited to the range of 0.1 to 0.53. (Appendix 1 Figure A12.1). See Appendix 5 for more information.







**Note 2** Very low values of  $Q_{BAR}/A$  result in excessive storage volumes. As Long Term storage for SOIL type 1 is large, a minimum value of  $Q_{BAR}/A$  of 1 is to be used.

**Note 3** Minimum sizes of an orifice may limit the minimum hydraulic control flow rate. This allows the derivation of an equivalent value of a  $Q_{BAR}/A$ .

**Note 4** The use of the correlation equation of the FEH Statistical equation can be used, together with FSSR 14 growth curve factors to convert  $Q_{MED}$  to  $Q_{BAR}$ . See section 5 for the correlation equation.

# Appendix D Exploratory Hole Locations Plan

**KEY**

-  ACCESS ROUTES TO EXPLORATORY LOCATIONS
  -  MR PHIPPS
  -  PROPOSED EXPLORATORY HOLES NOT COMPLETED DUE TO ACCESS RESTRICTIONS
  -  ROTARY BOREHOLE - ALL CORED TO 7.0m
  -  TP1 TRIAL PIT
  -  BH4 ROTARY BOREHOLE - ALL CORED TO 7.0m WITH MONITORING WELLS
- TP8, BH4A AND BH4 ARE APPROXIMATE LOCATIONS ONLY. ALL OTHER LOCATIONS RECORDED USING GPS.

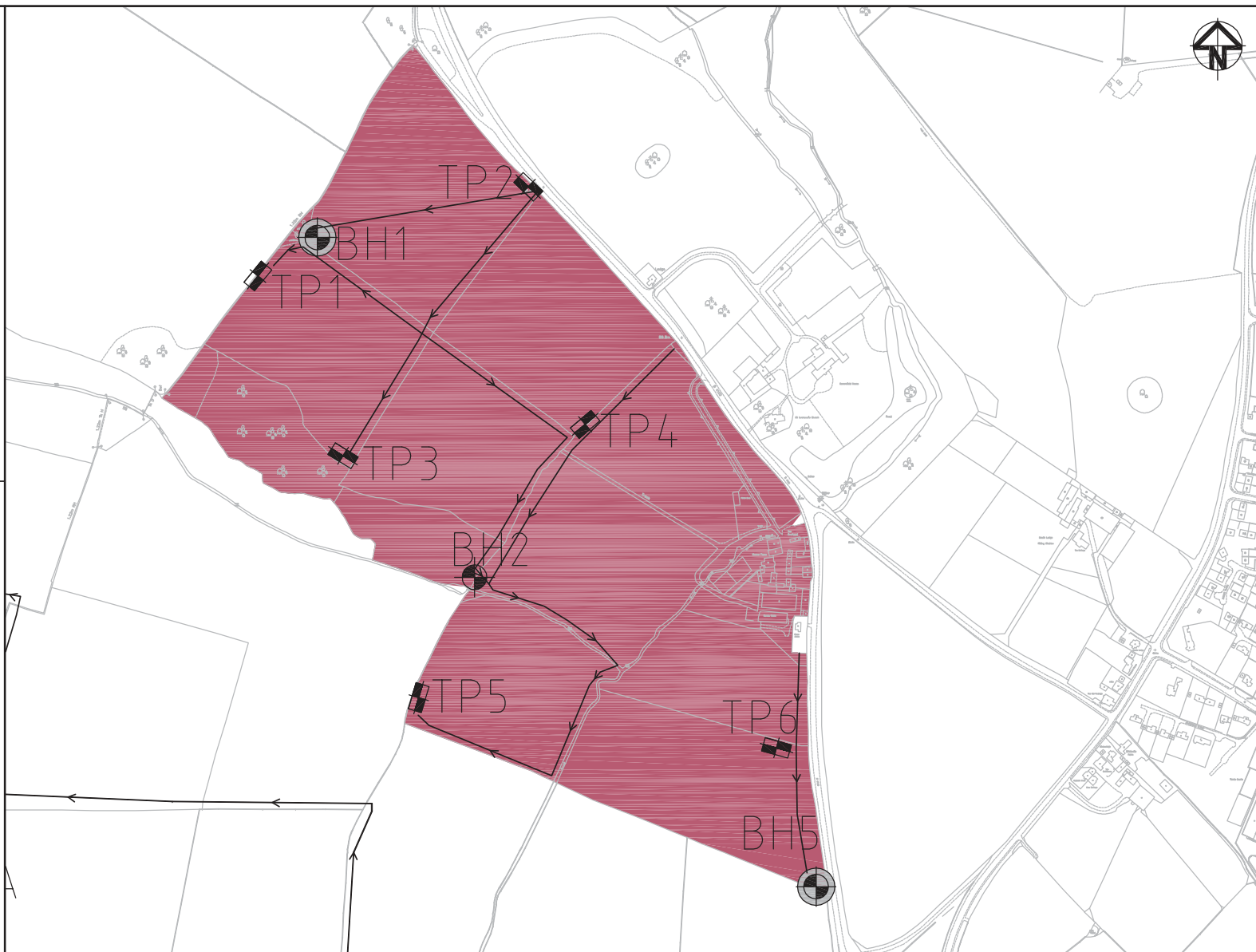

01	FIRST ISSUE	16/09/10
Issue	Description	Date

Client



Status	<b>PRELIMINARY NOT TO BE USED FOR CONSTRUCTION</b>	
Scales	1:12,500	Current Issue Signatures
Original Size	A3	Author R.JORDAN
Height	-	Checker D.THOMAS
Datum	-	Approver C.PLUMB
Grid	GRID	© Copyright reserved
Filename	2004-UA001881-UP33D-01.DWG	

Project	BICESTER ECO TOWN
Title	EXEMPLAR SITE WITH EXPLORATORY HOLE LOCATIONS



Hyder Consulting (UK) Limited  
29, Bressenden Place  
London  
SW1E 5DZ

Tel: +44 (0)870 000 3006  
Fax: +44 (0)870 000 3906

Drawing No.	Project No.	Issue
2004	UA001881	01

50mm on Original

## **Appendix E Preliminary Surface Water Drainage Layout and Details, 41436/2002/001, 003 & 004**



- NOTES:**
- DO NOT SCALE THIS DRAWING. IF IN DOUBT PLEASE REQUEST FURTHER INFORMATION.
  - ALL DIMENSIONS ARE IN METRES UNLESS STATED OTHERWISE.
  - THIS DRAWING IS TO BE READ IN CONJUNCTION WITH ALL OTHER RELEVANT CONTRACT DRAWINGS, CONSTRUCTION DETAILS AND SPECIFICATIONS.
  - PROPOSED SITE LAYOUT TAKEN FROM DAVID LOCK ASSOCIATES DRAWING RPC001-016 DATED 05/03/2018.

- KEY:**
- PROPOSED SURFACE WATER SEWER AND MANHOLE
  - PROPOSED FLOW CONTROL MANHOLE
  - PROPOSED NON-RETURN VALVE MANHOLE
  - PROPOSED PETROL INTERCEPTOR
  - PROPOSED HEADWALL
  - PROPOSED DETENTION BASIN
  - PROPOSED PERMEABLE PAVING

Mark	Revision	Date	Drawn	Chkd	Appd

SCALING NOTE: Do not scale from this drawing. If in doubt, ask.  
 UTILITIES NOTE: The position of any existing public or private sewers, utility services, plant or apparatus shown on this drawing is believed to be correct, but no warranty to this is expressed or implied. Other such plant or apparatus may also be present but not shown. The Contractor is therefore advised to undertake their own investigation where the presence of any existing sewers, services, plant or apparatus may affect their operations.

Drawing Issue Status  
**FOR INFORMATION**

**PLOT SGR 1, BICESTER**  
**PROPOSED SURFACE WATER DRAINAGE STRATEGY**

Client  
**SGR (BICESTER 1) LIMITED**

Date of 1st Issue 16.03.2018	Designed -	Drawn CL
A1 Scale 1:500	Checked MG	Approved CMB
Drawing Number 41436/2002/001	Revision -	





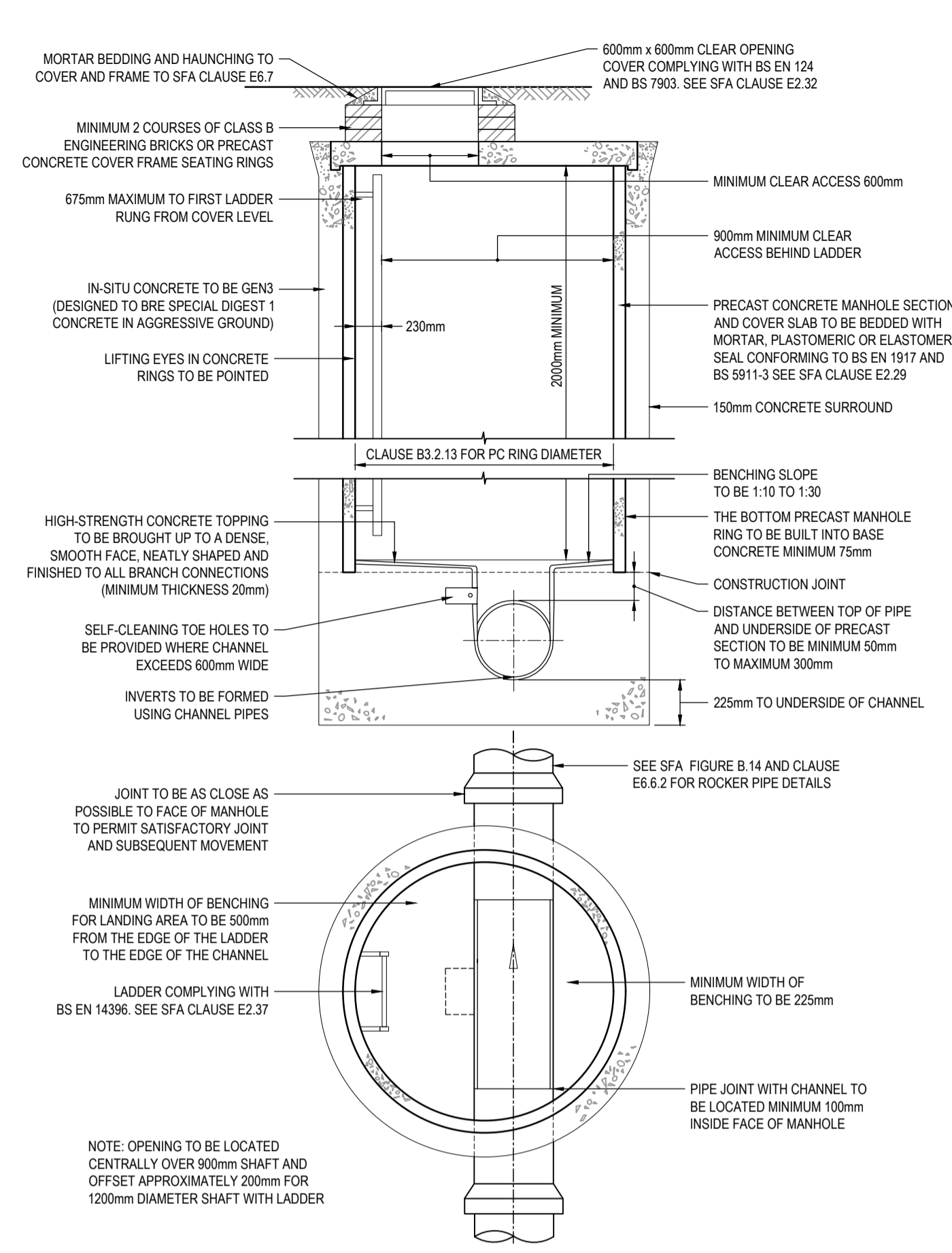

**TYPICAL MANHOLE DETAIL - TYPE 1B**  
DEPTH FROM COVER LEVEL TO SOFFIT OF PIPE 3m to 6m

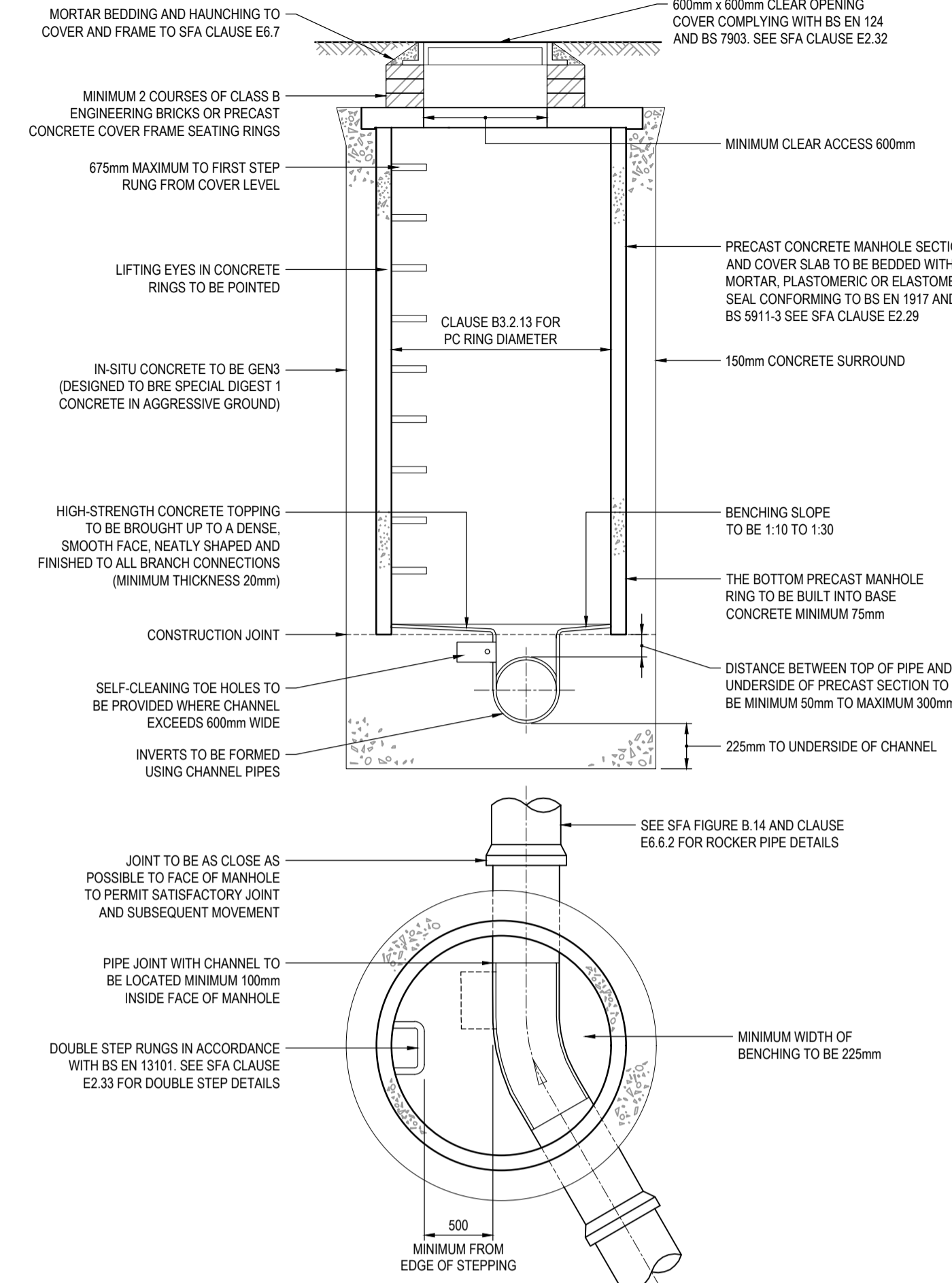

**TYPICAL MANHOLE DETAIL - TYPE 2**  
DEPTH FROM COVER LEVEL TO SOFFIT OF PIPE UP TO 3m

MANHOLE DIAMETERS	
NOMINAL INTERNAL DIAMETER OF LARGEST PIPE IN MANHOLE (mm)	MINIMUM NOMINAL INTERNAL DIMENSION OF MANHOLE (mm)
LESS THAN 375	1200
375 - 450	1350
500 - 700	1500
750 - 900	1800
GREATER THAN 900	PIPE DIAMETER + 900

ROCKER PIPE LENGTH	
NOMINAL DIAMETER (mm)	EFFECTIVE LENGTH (mm)
150 - 600	600
600 - 750	1000
OVER 750	1250

- NOTES:**
- DO NOT SCALE FROM THIS DRAWING. USE FIGURED DIMENSIONS ONLY. ALL DIMENSIONS ARE IN MILLIMETRES.
  - FOR DATED REFERENCES, SUBSEQUENT AMENDMENTS TO, OR REVISIONS OF, ANY OF THESE PUBLICATIONS DO NOT APPLY. FOR UNDATED REFERENCES, THE LATEST EDITION OF THE PUBLICATION REFERRED TO APPLIES.
  - THIS DRAWING IS TO BE READ IN CONJUNCTION WITH ALL OTHER RELEVANT DRAWINGS AND THE SPECIFICATION.
  - MANHOLE COVERS AND FRAMES - SHALL COMPLY WITH THE RELEVANT PROVISIONS OF BS EN 124. THEY SHALL BE OF A NON-ROCKING DESIGN WHICH DOES NOT RELY ON THE USE OF CUSHION INSERTS. CLASS D400 COVERS SHALL BE USED (INCLUDING PEDESTRIAN STREETS), HARD SHOULDERS AND PARKING USED BY ALL TYPES OF ROAD VEHICLE. CLASS B125 SHALL BE USED IN FOOTWAYS, PEDESTRIAN AREAS AND COMPARABLE LOCATIONS. MINIMUM FRAME DEPTHS FOR NRSWA ROAD CATEGORIES I TO IV SHALL BE 150mm (EXCEPT RESIDENTIAL CUL-DE-SACS WHERE THE MINIMUM FRAME DEPTH SHALL BE 100mm). ALL MANHOLES COVERS SHALL BE THE NON-VENTILATING TYPE AND HAVE CLOSED KEYWAYS. IN VERGES COVERS SHALL BE POSITIONED ON THE SIDE FURTHEST FROM THE CARRIAGEWAY.
  - ACCESS - DOUBLE ENCAPSULATED STEP RUNGS ARE TO BE FITTED WITHIN THE MANHOLE FOR ACCESS. THE TOP RUNG SHOULD BE A MAXIMUM OF 675mm BELOW GROUND LEVEL.
  - BRICKS - SHALL BE CLASS B ENGINEERING COMPLYING WITH THE RELEVANT PROVISIONS OF BS 912. ALL BRICKS SHALL BE FROST RESISTANT CATEGORY F.
  - MORTAR - SHALL BE MIXED ONLY AS AND WHEN REQUIRED, IN THE PROPORTION 1:3 CEMENT SAND BY VOLUME. ALL MORTAR SHALL BE CONVEYED FRESH TO THE WORKS AS REQUIRED FOR USE. MORTAR WHICH HAS BEGUN TO SET OR WHICH HAS BEEN MIXED FOR A PERIOD OF MORE THAN 1 HOUR SHALL NOT BE USED.
  - SANDS FOR MORTAR - SHALL BE WASHED SAND, COMPLYING WITH BS 1200 AND GRADED IN ACCORDANCE WITH TABLE 1 OF THAT STANDARD.
  - CEMENT (FOR INSITU CONCRETE AND MORTAR) - SHALL BE SULPHATE RESISTING PORTLAND CEMENT (SRPC) COMPLYING WITH BS 4027.
  - CEMENT (FOR PRECAST CONCRETE PIPES OR MANHOLES) - SHALL BE A COMBINATION OF CEMENT CONFORMING TO BS 12 AND G.G.B.S OR P.F.A. OR CEMENT CONFORMING TO BS 4027 ALONE TO MEET UP TO AND INCLUDING DESIGN SULPHATE CLASS S3 AS DEFINED IN BRE SPECIAL DIGEST 1, 2001.
  - WATER FOR USE WITH CEMENT - SHALL BE OF POTABLE QUALITY.
  - PRECAST CONCRETE MANHOLE COMPONENTS - SHALL COMPLY WITH THE RELEVANT PROVISIONS OF BS 5911-200. UNITS WHICH BED INTO BASES SHALL BE MANUFACTURED SO THAT IMPOSED VERTICAL LOADS ARE TRANSMITTED DIRECTLY VIA THE FULL WALL THICKNESS OF THE UNIT. FOR JOINTS BETWEEN UNITS AND THE UNDERSIDE OF SLABS, JOINT PROFILES SHALL BE CAPABLE OF WITHSTANDING APPLIED LOADINGS FROM SUCH SLABS, AND SPOT-ENDED SECTIONS SHALL ONLY BE USED WHERE THE SOFFIT OF THE SLAB IS RECESSED TO RECEIVE THEM.

- IN SITU CONCRETE - STANDARDISED PRESCRIBED CONCRETE MIX S14 (UNREINFORCED) IN ACCORDANCE WITH BS 8500-2 AND BS EN 206-1 SHALL BE USED WITH A 20mm NOMINAL MAXIMUM SIZE OF AGGREGATE AND A CLASS S2 (75mm) SLUMP. ADMIXTURES (INCLUDING CALCIUM CHLORIDE AND PIGMENTS) SHALL NOT BE USED IN THE PRODUCTION OF CONCRETE. COMPRESSIVE STRENGTH TESTING SHALL NOT BE USED TO JUDGE THE COMPLIANCE OF A CONCRETE, BUT WHERE REQUIRED BY THE ADOPTING AUTHORITY, THE CONTRACTOR SHALL PROVIDE EVIDENCE OF THE BATCH MASSES USED TO PRODUCE ANY CONCRETE.
- STANDARDISED PRESCRIBED CONCRETE PRODUCED USING SULPHATE-RESISTING PORTLAND CEMENT IS NOT INTENDED TO PRODUCE SULPHATE-RESISTING CONCRETE. WHERE THE DESIGN SULPHATE CLASS IS HIGHER THAN DESIGN SULPHATE CLASS S2, IN-SITU CONCRETE (AND PRECAST CONCRETE, WHERE APPLICABLE) SHALL BE AS DESIGNATED ON THE CONTRACT SPECIFIC DRAINAGE LAYOUT DRAWING, MANHOLE SCHEDULE OR SPECIFICATION.
- AGGREGATES FOR CONCRETE - SHALL COMPLY WITH THE RELEVANT PROVISIONS OF BS 882.
- HIGH STRENGTH CONCRETE TOPPING - SHALL BE PRODUCED, LAID AND FINISHED IN ACCORDANCE WITH THE RELEVANT PROVISIONS OF BS 8204, PART 2 AND THE FOLLOWING APPROXIMATE MIX PROPORTIONS BY WEIGHT SHALL BE USED: 1 PART CEMENT, 1 PART NATURAL SAND AND 2 PARTS SINGLE SIZED COARSE AGGREGATE.
- AGGREGATE FOR HIGH STRENGTH CONCRETE TOPPING - SHALL COMPLY WITH BS 882 AND BE 10mm NOMINAL SIZE, GRADED IN ACCORDANCE WITH TABLE 6 OF THAT STANDARD.
- WHEN THIS STANDARD IS SUPERSEDED BY EN 12620, THE AGGREGATES SHALL FOLLOW THE RECOMMENDATIONS IN THE UK NATIONAL GUIDANCE TO EN 12620.
- THE ADOPTING AUTHORITY'S STANDARD DETAILS, WHERE THEY EXIST, SHALL BE USED IN PREFERENCE TO THIS STANDARD DETAIL.
- ALL THE ABOVE REQUIREMENTS SHALL APPLY UNLESS OTHERWISE STATED IN THE DRAINAGE LAYOUT DRAWING, MANHOLE SCHEDULE OR SPECIFICATION. IN THE EVENT OF A CONTRADICTION THE CONTRACT SPECIFIC DOCUMENTS SHALL BE DEEMED TO PREVAIL.
- ALL ADOPTABLE WORKS SHALL BE CARRIED OUT IN ACCORDANCE WITH SEWERS FOR ADOPTION 7<sup>TH</sup> EDITION (SFA).

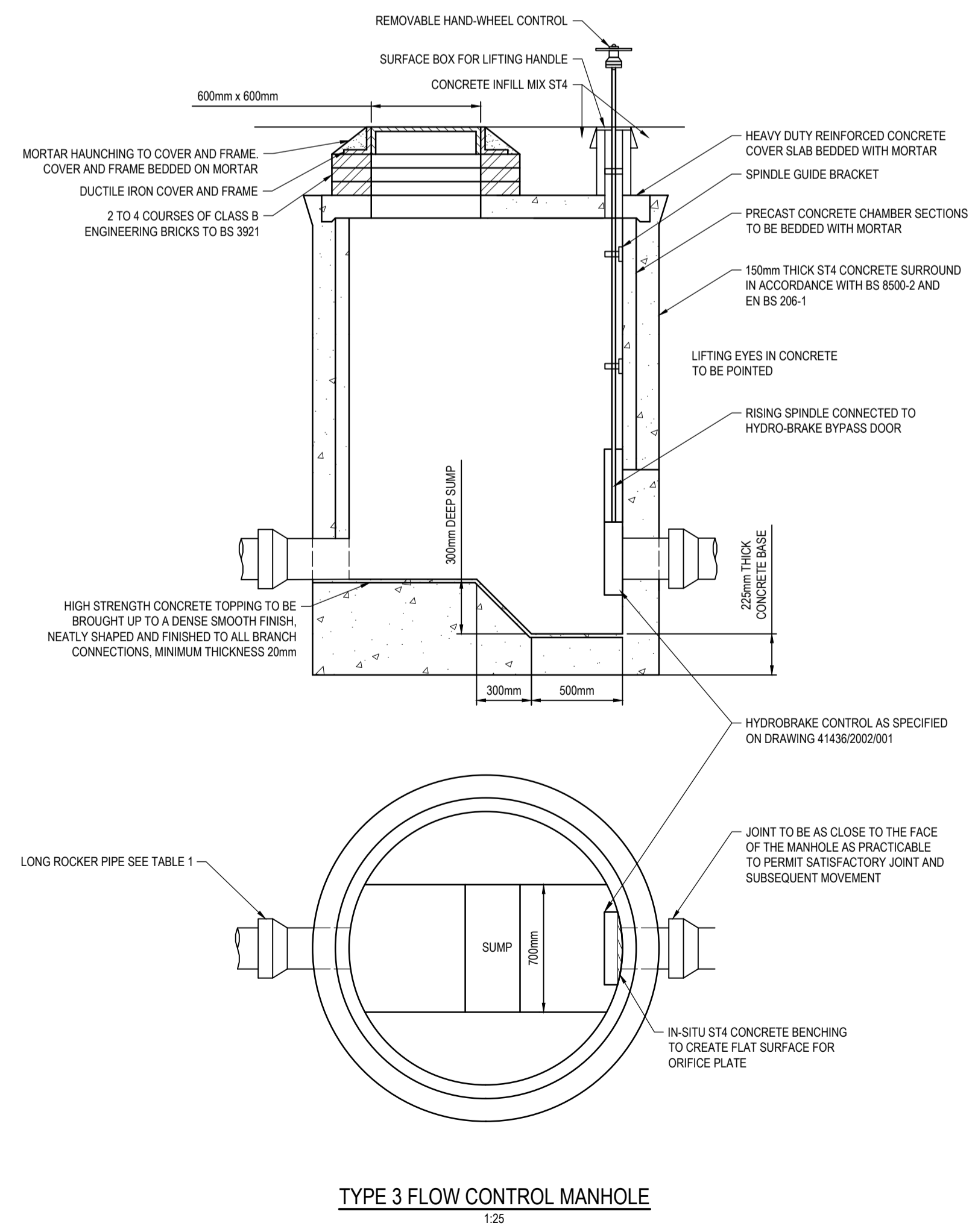

**TYPE 3 FLOW CONTROL MANHOLE**  
1:25

**MANHOLE AND INSPECTION CHAMBER NOTES**

- CONSTRUCTION SHALL COMPLY WITH THE REQUIREMENTS AND SPECIFICATION OF MCHW AND THOSE SPECIFIC REQUIREMENTS OF THE ADOPTING STATUTORY UNDERTAKER.
- ALL PIPES TO BE EITHER VITRIFIED CLAY OR CONCRETE AS PER THE MCHW.
- RISING SPINDLE AND GUIDE BRACKETS TO BE STAINLESS STEEL A131 316L TO BS EN 10088.
- HYDROBRAKE TO BE INSTALLED IN ACCORDANCE WITH MANUFACTURES INSTRUCTIONS.

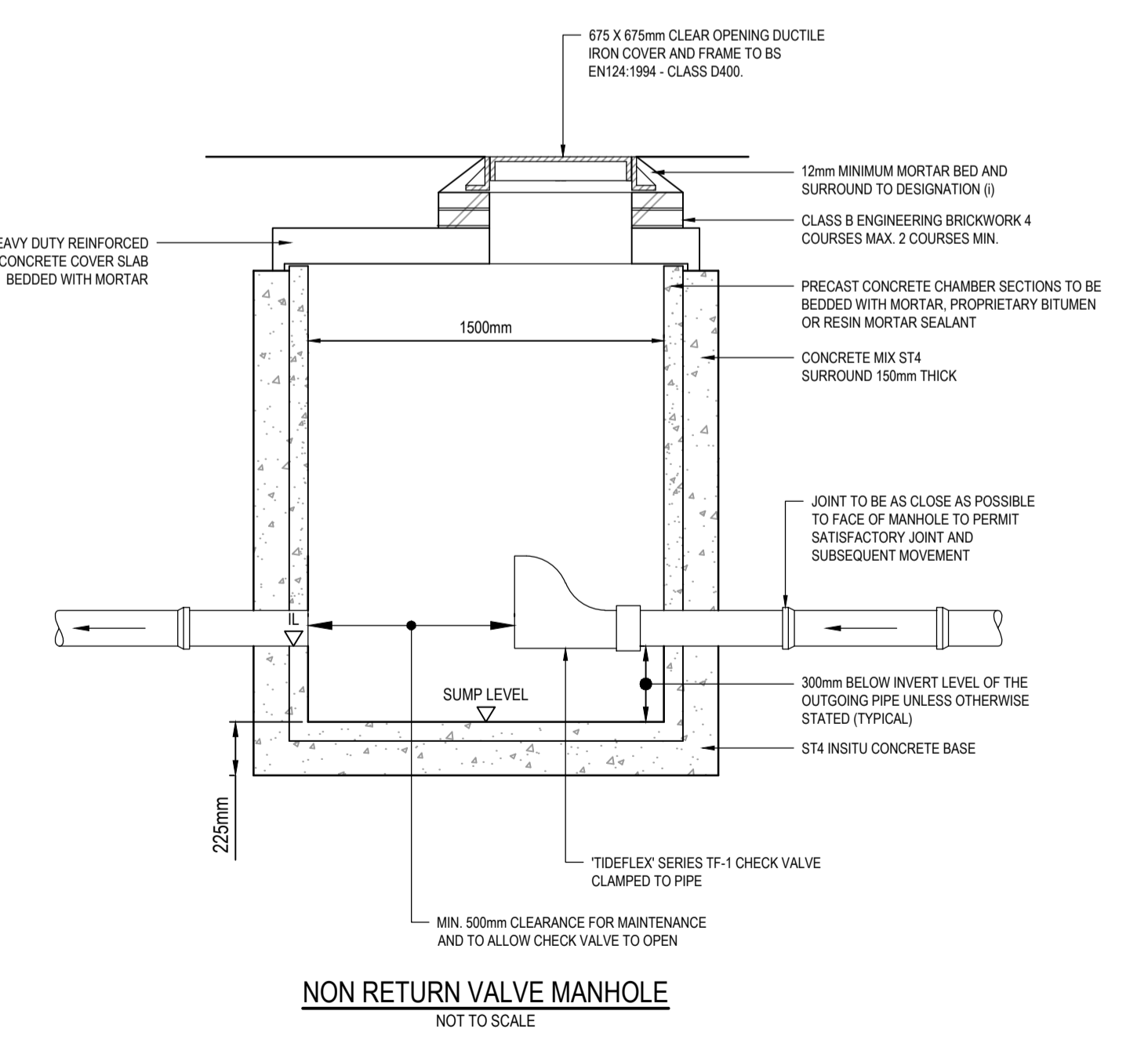
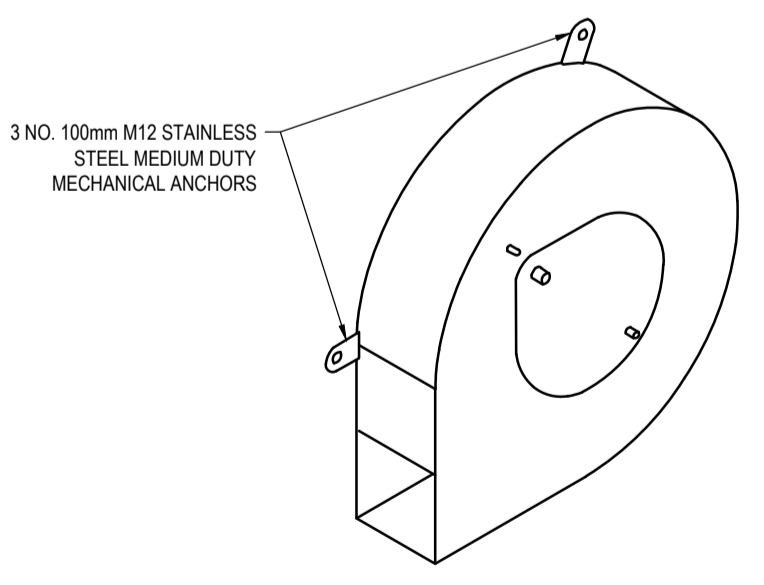

**NON RETURN VALVE MANHOLE**  
NOT TO SCALE

Mark	Revision	Date	Drawn	Chkd	Appd

SCALING NOTE: Do not scale from this drawing. If in doubt, ask.  
UTILITIES NOTE: The position of any existing public or private sewers, utility services, plant or apparatus shown on this drawing is believed to be correct, but no warranty to this is expressed or implied. Other such plant or apparatus may also be present but not shown. The Contractor is therefore advised to undertake their own investigation where the presence of any existing sewers, services, plant or apparatus may affect their operations.

Drawing Issue Status  
**FOR INFORMATION**

**PLOT SGR 1, BICESTER**  
**DRAINAGE CONSTRUCTION DETAILS**  
**SHEET 1 OF 2**

Client <b>SGR (BICESTER 1) LIMITED</b>		
Date of 1st Issue 16.03.2018	Designed -	Drawn CL
A1 Scale AS SHOWN	Checked MG	Approved CMB
Drawing Number 41436/2002/003	Revision -	

**NOTES:**

- ALL DIMENSIONS ARE IN MILLIMETRES.
- WATER AUTHORITIES ASSOCIATION GUIDE SEWERS FOR ADOPTION LATEST EDITION APPLIES EXCEPT WHERE MODIFIED BY THIS DRAWING.
- PIPES SHALL BE :  
VITRIFIED CLAY PIPES TO BS 65 (1991) AND BS EN 295 (1991)  
CONCRETE PIPES TO BS 5911 (2002)
- MINIMUM COVER WITHOUT CONCRETE PROTECTION IS 1200mm.  
CONCRETE PROTECTION TO TERMINATE AT SUITABLE PIPE JOINT.
- FLEXIBLE JOINTS MUST BE PROVIDED IN CONCRETE BED AND SURROUND OR REINFORCED SLAB.
- CEMENT (FOR INSITU CONCRETE AND MORTAR) - SHALL BE SULPHATE RESISTING PORTLAND CEMENT (SRPC) COMPLYING WITH BS 4027

**CONCRETE AND CLAY PIPES:**

- DETERMINATION OF PIPE AND BEDDING COMBINATIONS SHALL BE IN ACCORDANCE WITH MCHW ADVICE NOTE HA 40/01.
- IF MAXIMUM TRENCH WIDTH IS EXCEEDED IT MAY BE NECESSARY TO INCREASE THE STRENGTH OF THE PIPE.

**ALL PIPES:**

- PIPE AND BEDDING MUST BE ADEQUATE FOR THE WORST CONDITIONS AND MATERIALS MUST NOT BE CHANGED BETWEEN CHAMBERS.
- MINIMUM PIPE DIAMETER TO BE 225mm FOR CARRIER DRAINS.
- SADDLE CONNECTIONS MAY ONLY BE USED WITH THE APPROVAL OF THE ENGINEER.
- CARRIER DRAINS WILL NOT NORMALLY BE PERMITTED IN FOOTWAYS OR CYCLEWAYS.
- EXISTING CARRIAGEWAY SHALL BE REINSTATED IN ACCORDANCE WITH HAUC SPECIFICATION FOR REINSTATEMENT OF OPENINGS IN HIGHWAYS.

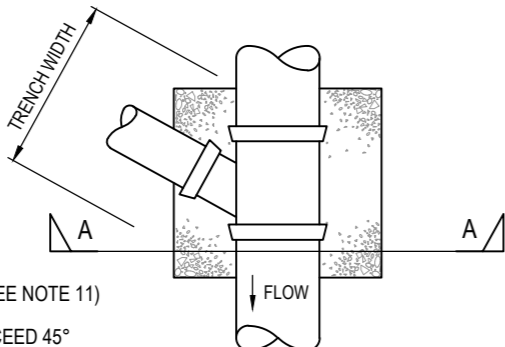
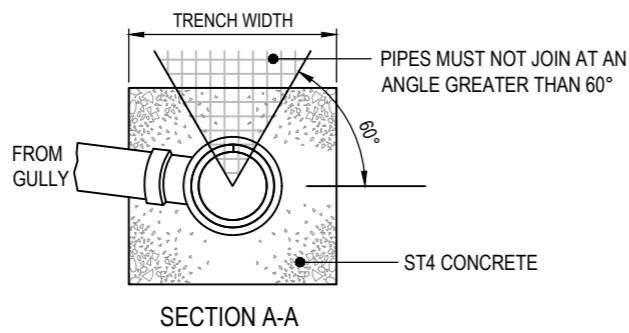
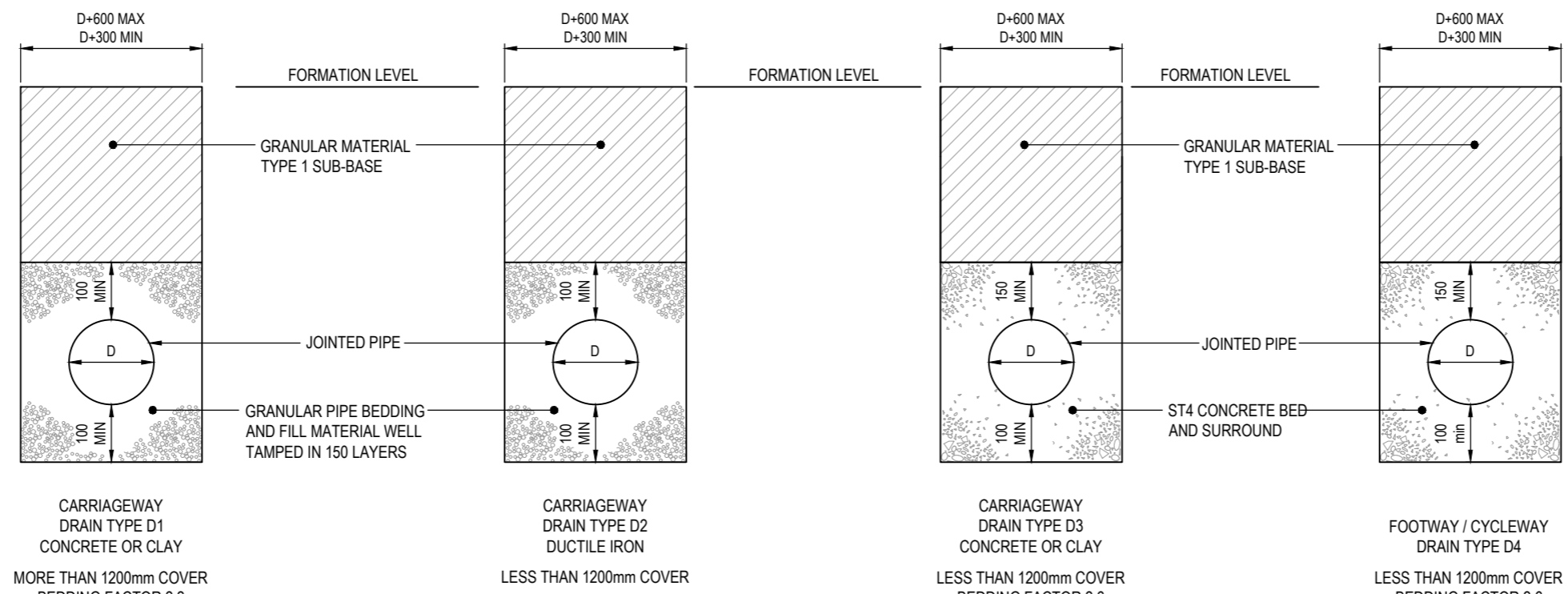

GULLY CONNECTION DETAIL (SEE NOTE 11)  
SINGLE BENDS MUST NOT EXCEED 45°  
CUMULATIVE BENDS MUST NOT EXCEED 90°

**PIPE BEDDING DETAILS**  
NOT TO SCALE

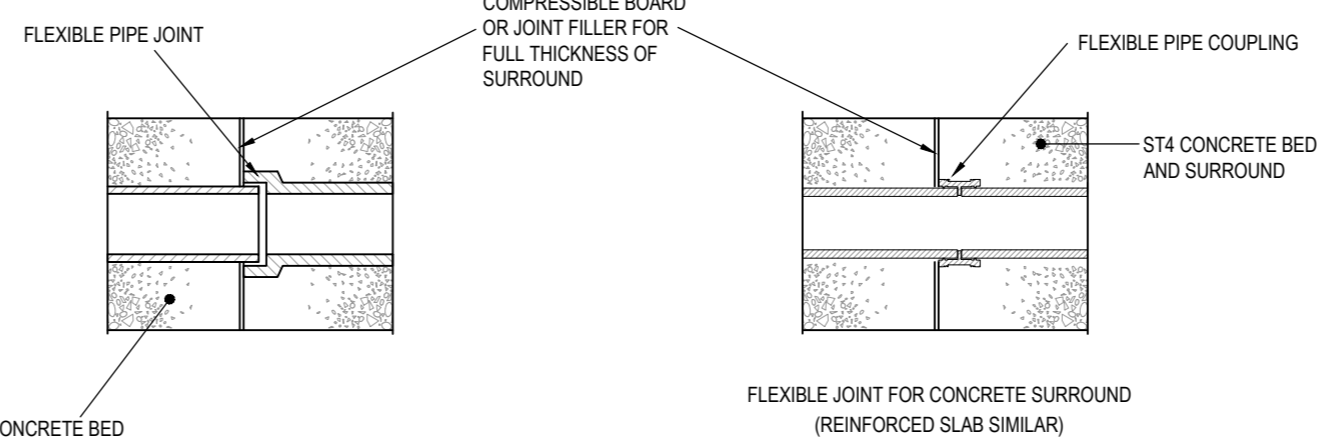

SAFE SUPPORTING STRENGTH OF PIPE  $WS = \frac{WT \cdot FM}{FS}$   
 WHERE  
 WT = CRUSHING STRENGTH - SEE BRITISH STANDARDS  
 FM = BEDDING FACTOR  
 FS = FACTOR OF SAFETY = 1.25

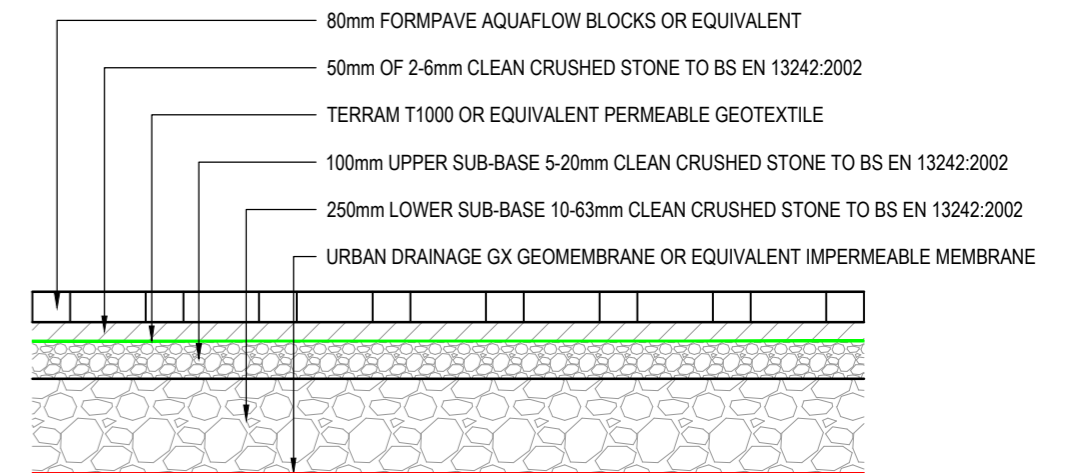

**PERMEABLE PAVING**  
NOT TO SCALE

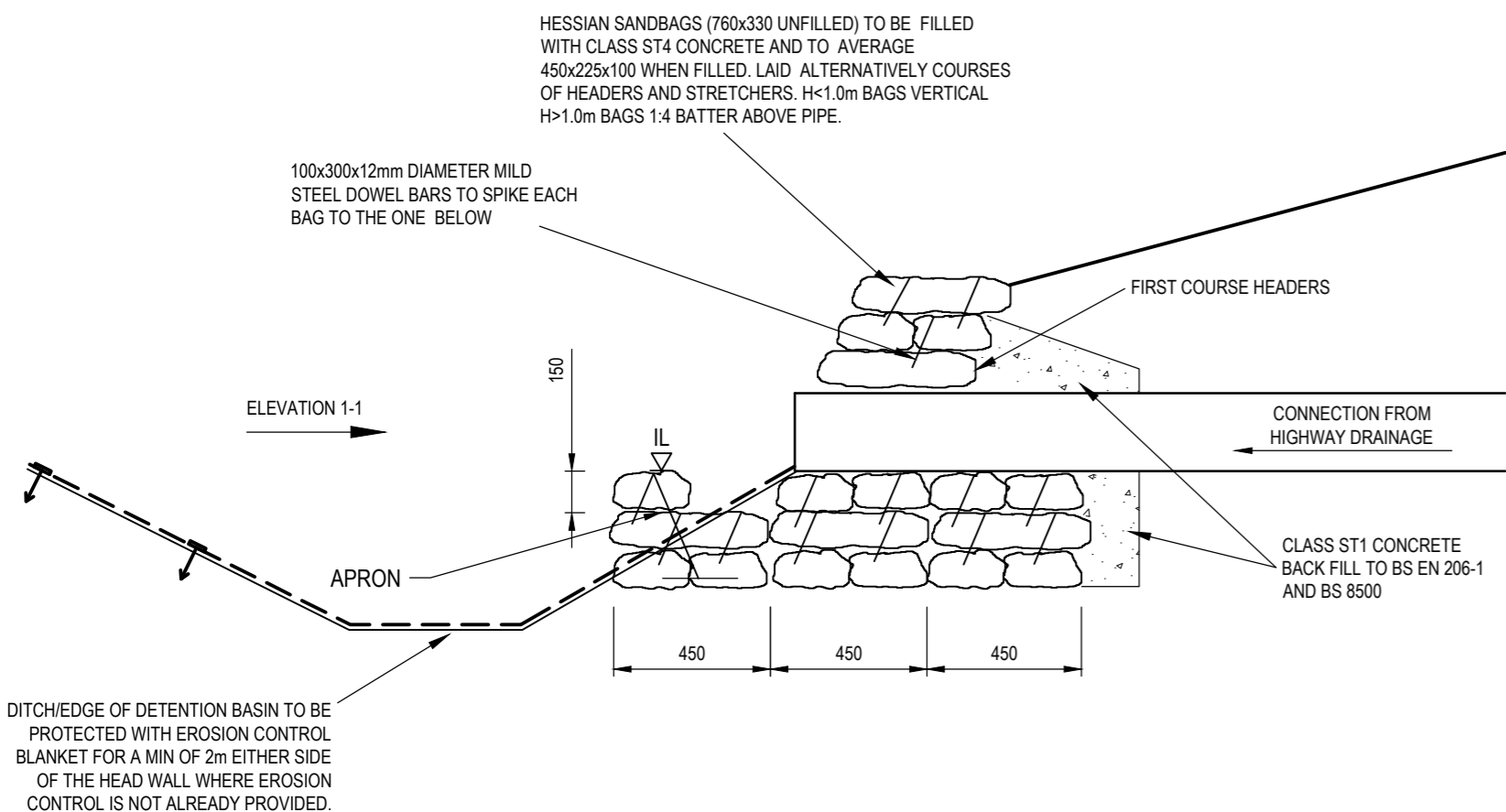

**TYPICAL BAGWORK HEADWALL DETAIL**  
1:20

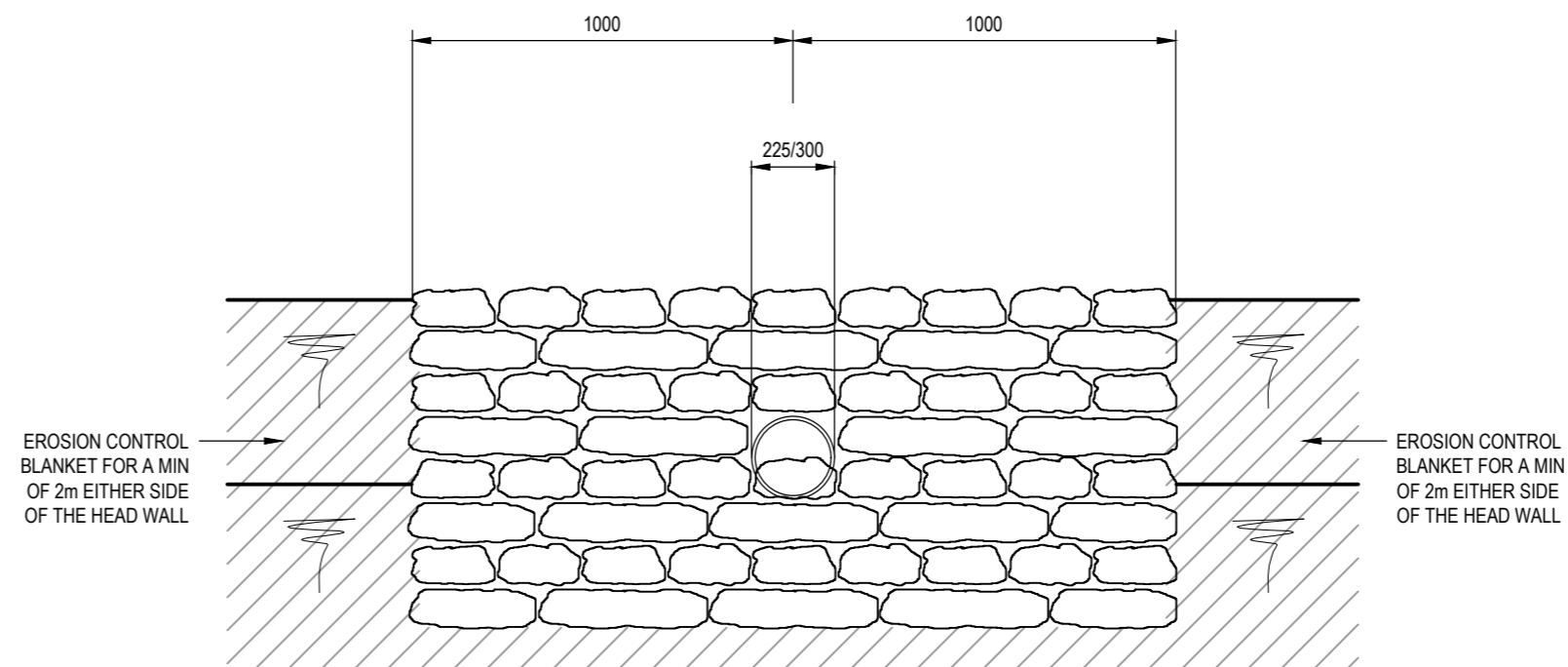

**ELEVATION 1-1**  
1:20

Mark	Revision	Date	Drawn	Chkd	Appd

SCALING NOTE: Do not scale from this drawing. If in doubt, ask.  
 UTILITIES NOTE: The position of any existing public or private sewers, utility services, plant or apparatus shown on this drawing is believed to be correct, but no warranty to this is expressed or implied. Other such plant or apparatus may also be present but not shown. The Contractor is therefore advised to undertake their own investigation where the presence of any existing sewers, services, plant or apparatus may affect their operations.

**Drawing Issue Status**  
**FOR INFORMATION**

**PLOT SGR 1, BICESTER**  
**DRAINAGE CONSTRUCTION DETAILS**  
**SHEET 2 OF 2**

Client  
**SGR (BICESTER 1) LIMITED**

Date of 1st Issue	Designed	Drawn
16.03.2018	-	CL
A2 Scale	Checked	Approved
AS SHOWN	MG	CMB

Drawing Number	Revision
<b>41436/2002/004</b>	-



Offices throughout the UK and Europe  
**www.peterbrett.com**  
 © Peter Brett Associates LLP  
 READING  
 Tel: 01189 500 761

# Appendix F Overland Flow Route Drawing



- NOTES:**
- DO NOT SCALE THIS DRAWING. IF IN DOUBT PLEASE REQUEST FURTHER INFORMATION.
  - ALL DIMENSIONS ARE IN METRES UNLESS STATED OTHERWISE.
  - THIS DRAWING IS TO BE READ IN CONJUNCTION WITH ALL OTHER RELEVANT CONTRACT DRAWINGS, CONSTRUCTION DETAILS AND SPECIFICATIONS.
  - PROPOSED SITE LAYOUT TAKEN FROM DAVID LOCK ASSOCIATES DRAWING RPC001-016 DATED 05.03.2018.

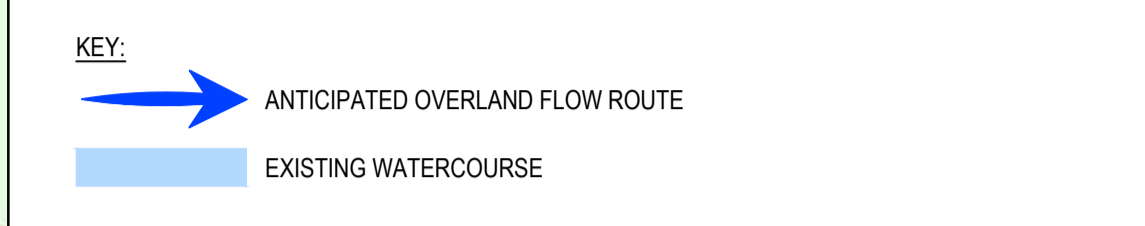

Mark	Revision	Date	Drawn	Chkd	Appd

SCALING NOTE: Do not scale from this drawing. If in doubt, ask.  
 UTILITIES NOTE: The position of any existing public or private sewers, utility services, plant or apparatus shown on this drawing is believed to be correct, but no warranty to this is expressed or implied. Other such plant or apparatus may also be present but not shown. The Contractor is therefore advised to undertake their own investigation where the presence of any existing sewers, services, plant or apparatus may affect their operations.

Drawing Issue Status  
**FOR INFORMATION**

PLOT SGR 1, BICESTER  
 OVERLAND FLOW ROUTE

Client <b>SGR (BICESTER 1) LIMITED</b>			 Offices throughout the UK and Europe <a href="http://www.peterbrett.com">www.peterbrett.com</a> © Peter Brett Associates LLP READING Tel: 01189 500 761
Date of 1st Issue 16.03.2018	Designed -	Drawn CL	
A1 Scale 1:500	Checked MG	Approved CMB	
Drawing Number 41436/2002/002	Revision -		

# Appendix G MicroDrainage Calculations

Peter Brett Associates LLP		Page 1
Caversham Bridge House	Plot SGR 1	
Waterman Place	Bicester	
Reading Berkshire RG1 8DN	SW Drainage Design	
Date 14/03/2018 17:59	Designed by MG	
File 41436_2002_SW_NETWORK_REV...	Checked by CB	
Micro Drainage	Network 2017.1.2	

STORM SEWER DESIGN by the Modified Rational Method

Design Criteria for Storm









Pipe Sizes STANDARD Manhole Sizes STANDARD

FSR Rainfall Model - England and Wales

Return Period (years)	2	PIMP (%)	100
M5-60 (mm)	20.000	Add Flow / Climate Change (%)	0
Ratio R	0.405	Minimum Backdrop Height (m)	0.200
Maximum Rainfall (mm/hr)	0	Maximum Backdrop Height (m)	1.500
Maximum Time of Concentration (mins)	30	Min Design Depth for Optimisation (m)	1.200
Foul Sewage (l/s/ha)	0.000	Min Vel for Auto Design only (m/s)	1.00
Volumetric Runoff Coeff.	0.750	Min Slope for Optimisation (1:X)	500

Designed with Level Soffits

Network Design Table for Storm

PN	Length (m)	Fall (m)	Slope (1:X)	I.Area (ha)	T.E. (mins)	Base Flow (l/s)	k (mm)	HYD SECT	DIA (mm)	Section Type	Auto Design
1.000	40.851	0.245	167.0	0.032	4.00	0.0	0.600	o	225	Pipe/Conduit	
2.000	19.825	0.245	80.9	0.014	4.00	0.0	0.600	o	225	Pipe/Conduit	
1.001	22.949	0.455	50.4	0.057	0.00	0.0	0.600	o	225	Pipe/Conduit	
1.002	39.490	0.400	98.7	0.032	0.00	0.0	0.600	o	225	Pipe/Conduit	
1.003	21.622	0.100	216.2	0.057	0.00	0.0	0.600	o	300	Pipe/Conduit	
1.004	32.816	0.415	79.1	0.063	0.00	0.0	0.600	o	300	Pipe/Conduit	
3.000	15.960	0.580	27.5	0.005	4.00	0.0	0.600	o	225	Pipe/Conduit	
4.000	26.031	0.200	130.2	0.107	4.00	0.0	0.600	o	300	Pipe/Conduit	
4.001	29.607	0.180	164.5	0.053	0.00	0.0	0.600	o	300	Pipe/Conduit	

Network Results Table

PN	Rain (mm/hr)	T.C. (mins)	US/IL (m)	Σ I.Area (ha)	Σ Base Flow (l/s)	Foul (l/s)	Add Flow (l/s)	Vel (m/s)	Cap (l/s)	Flow (l/s)
1.000	0.00	4.67	88.875	0.032	0.0	0.0	0.0	1.01	40.1	0.0
2.000	0.00	4.23	88.875	0.014	0.0	0.0	0.0	1.45	57.8	0.0
1.001	0.00	4.88	88.630	0.103	0.0	0.0	0.0	1.85	73.4	0.0
1.002	0.00	5.38	88.175	0.135	0.0	0.0	0.0	1.32	52.3	0.0
1.003	0.00	5.72	87.700	0.192	0.0	0.0	0.0	1.07	75.3	0.0
1.004	0.00	6.03	87.600	0.255	0.0	0.0	0.0	1.77	125.1	0.0
3.000	0.00	4.11	88.075	0.005	0.0	0.0	0.0	2.50	99.6	0.0
4.000	0.00	4.32	87.800	0.107	0.0	0.0	0.0	1.38	97.3	0.0
4.001	0.00	4.72	87.600	0.160	0.0	0.0	0.0	1.22	86.5	0.0

Caversham Bridge House  
 Waterman Place  
 Reading Berkshire RG1 8DN

Plot SGR 1  
 Bicester  
 SW Drainage Design



Date 14/03/2018 17:59

Designed by MG

File 41436\_2002\_SW\_NETWORK\_REV...

Checked by CB

Micro Drainage

Network 2017.1.2

Network Design Table for Storm

PN	Length (m)	Fall (m)	Slope (1:X)	I.Area (ha)	T.E. (mins)	Base Flow (l/s)	k (mm)	HYD SECT	DIA (mm)	Section Type	Auto Design
3.001	23.871	0.145	164.6	0.025	0.00	0.0	0.600	o	300	Pipe/Conduit	
3.002	21.464	0.090	238.0	0.028	0.00	0.0	0.600	o	300	Pipe/Conduit	
1.005	45.992	0.435	105.7	0.042	0.00	0.0	0.600	o	450	Pipe/Conduit	
1.006	13.611	0.035	385.0	0.031	0.00	0.0	0.600	o	450	Pipe/Conduit	
1.007	38.555	0.660	58.4	0.029	0.00	0.0	0.600	o	450	Pipe/Conduit	
5.000	29.419	0.700	42.0	0.037	4.00	0.0	0.600	o	225	Pipe/Conduit	
6.000	26.214	0.300	87.4	0.010	4.00	0.0	0.600	o	225	Pipe/Conduit	
5.001	45.544	0.300	151.8	0.039	0.00	0.0	0.600	o	225	Pipe/Conduit	
5.002	30.886	0.300	103.0	0.059	0.00	0.0	0.600	o	225	Pipe/Conduit	
5.003	12.923	1.265	10.2	0.031	0.00	0.0	0.600	o	225	Pipe/Conduit	
7.000	42.889	0.260	165.0	0.045	4.00	0.0	0.600	o	225	Pipe/Conduit	
8.000	20.663	1.160	17.8	0.022	4.00	0.0	0.600	o	225	Pipe/Conduit	
7.001	34.921	0.210	166.3	0.026	0.00	0.0	0.600	o	225	Pipe/Conduit	
7.002	15.488	0.095	163.0	0.040	0.00	0.0	0.600	o	225	Pipe/Conduit	
5.004	16.162	0.070	230.9	0.004	0.00	0.0	0.600	o	300	Pipe/Conduit	

Network Results Table

PN	Rain (mm/hr)	T.C. (mins)	US/IL (m)	Σ I.Area (ha)	Σ Base Flow (l/s)	Foul (l/s)	Add Flow (l/s)	Vel (m/s)	Cap (l/s)	Flow (l/s)
3.001	0.00	5.04	87.420	0.190	0.0	0.0	0.0	1.22	86.4	0.0
3.002	0.00	5.40	87.275	0.218	0.0	0.0	0.0	1.01	71.7	0.0
1.005	0.00	6.42	87.035	0.515	0.0	0.0	0.0	1.98	314.4	0.0
1.006	0.00	6.64	86.600	0.546	0.0	0.0	0.0	1.03	163.8	0.0
1.007	0.00	6.88	86.565	0.575	0.0	0.0	0.0	2.66	423.7	0.0
5.000	0.00	4.24	88.875	0.037	0.0	0.0	0.0	2.02	80.5	0.0
6.000	0.00	4.31	88.475	0.010	0.0	0.0	0.0	1.40	55.6	0.0
5.001	0.00	5.03	88.175	0.086	0.0	0.0	0.0	1.06	42.1	0.0
5.002	0.00	5.43	87.875	0.145	0.0	0.0	0.0	1.29	51.2	0.0
5.003	0.00	5.48	87.575	0.176	0.0	0.0	0.0	4.12	163.7	0.0
7.000	0.00	4.70	86.875	0.045	0.0	0.0	0.0	1.02	40.4	0.0
8.000	0.00	4.11	87.775	0.022	0.0	0.0	0.0	3.12	123.9	0.0
7.001	0.00	5.28	86.615	0.093	0.0	0.0	0.0	1.01	40.2	0.0
7.002	0.00	5.53	86.405	0.133	0.0	0.0	0.0	1.02	40.6	0.0
5.004	0.00	5.79	86.235	0.313	0.0	0.0	0.0	1.03	72.8	0.0

Caversham Bridge House  
 Waterman Place  
 Reading Berkshire RG1 8DN

Plot SGR 1  
 Bicester  
 SW Drainage Design



Date 14/03/2018 17:59  
 File 41436\_2002\_SW\_NETWORK\_REV...

Designed by MG  
 Checked by CB

Micro Drainage

Network 2017.1.2

Network Design Table for Storm

PN	Length (m)	Fall (m)	Slope (1:X)	I.Area (ha)	T.E. (mins)	Base Flow (l/s)	k (mm)	HYD SECT	DIA (mm)	Section	Type	Auto Design
5.005	25.336	0.110	230.3	0.027	0.00	0.0	0.600	o	300	Pipe/Conduit		
9.000	21.195	0.130	163.0	0.046	4.00	0.0	0.600	o	225	Pipe/Conduit		
9.001	18.634	0.115	162.0	0.019	0.00	0.0	0.600	o	225	Pipe/Conduit		
1.008	10.231	0.025	409.2	0.040	0.00	0.0	0.600	o	525	Pipe/Conduit		
1.009	19.090	0.800	23.9	0.000	0.00	0.0	0.600	o	525	Pipe/Conduit		
1.010	39.797	1.755	22.7	0.000	0.00	0.0	0.600	o	150	Pipe/Conduit		
1.011	10.002	0.100	100.0	0.000	0.00	0.0	0.600	o	150	Pipe/Conduit		

Network Results Table

PN	Rain (mm/hr)	T.C. (mins)	US/IL (m)	Σ I.Area (ha)	Σ Base Flow (l/s)	Foul (l/s)	Add Flow (l/s)	Vel (m/s)	Cap (l/s)	Flow (l/s)
5.005	0.00	6.20	86.165	0.340	0.0	0.0	0.0	1.03	72.9	0.0
9.000	0.00	4.35	86.375	0.046	0.0	0.0	0.0	1.02	40.6	0.0
9.001	0.00	4.65	86.245	0.065	0.0	0.0	0.0	1.02	40.7	0.0
1.008	0.00	7.03	85.830	1.020	0.0	0.0	0.0	1.10	238.3	0.0
1.009	0.00	7.10	85.755	1.020	0.0	0.0	0.0	4.60	995.6	0.0
1.010	0.00	7.42	84.955	1.020	0.0	0.0	0.0	2.12	37.5	0.0
1.011	0.00	7.58	83.200	1.020	0.0	0.0	0.0	1.00	17.8	0.0



Caversham Bridge House  
 Waterman Place  
 Reading Berkshire RG1 8DN

Plot SGR 1  
 Bicester  
 SW Drainage Design



Date 14/03/2018 17:59

Designed by MG

File 41436\_2002\_SW\_NETWORK\_REV...

Checked by CB

Micro Drainage

Network 2017.1.2

PIPELINE SCHEDULES for Storm

Upstream Manhole

PN	Hyd Sect	Diam (mm)	MH Name	C.Level (m)	I.Level (m)	D.Depth (m)	MH Connection	MH DIAM., L*W (mm)
1.000	o	225	1	90.300	88.875	1.200	Open Manhole	1200
2.000	o	225	2	90.300	88.875	1.200	Open Manhole	1200
1.001	o	225	3	90.300	88.630	1.445	Open Manhole	1200
1.002	o	225	4	89.600	88.175	1.200	Open Manhole	1200
1.003	o	300	5	89.200	87.700	1.200	Open Manhole	1200
1.004	o	300	6	89.100	87.600	1.200	Open Manhole	1200
3.000	o	225	7	89.500	88.075	1.200	Open Manhole	1200
4.000	o	300	8	89.300	87.800	1.200	Open Manhole	1200
4.001	o	300	9	89.100	87.600	1.200	Open Manhole	1200
3.001	o	300	10	89.300	87.420	1.580	Open Manhole	1200
3.002	o	300	11	89.100	87.275	1.525	Open Manhole	1200
1.005	o	450	12	88.880	87.035	1.395	Open Manhole	1350
1.006	o	450	13	88.250	86.600	1.200	Open Manhole	1350
1.007	o	450	14	88.350	86.565	1.335	Open Manhole	1350
5.000	o	225	15	90.300	88.875	1.200	Open Manhole	1200

Downstream Manhole

PN	Length (m)	Slope (1:X)	MH Name	C.Level (m)	I.Level (m)	D.Depth (m)	MH Connection	MH DIAM., L*W (mm)
1.000	40.851	167.0	3	90.300	88.630	1.445	Open Manhole	1200
2.000	19.825	80.9	3	90.300	88.630	1.445	Open Manhole	1200
1.001	22.949	50.4	4	89.600	88.175	1.200	Open Manhole	1200
1.002	39.490	98.7	5	89.200	87.775	1.200	Open Manhole	1200
1.003	21.622	216.2	6	89.100	87.600	1.200	Open Manhole	1200
1.004	32.816	79.1	12	88.880	87.185	1.395	Open Manhole	1350
3.000	15.960	27.5	10	89.300	87.495	1.580	Open Manhole	1200
4.000	26.031	130.2	9	89.100	87.600	1.200	Open Manhole	1200
4.001	29.607	164.5	10	89.300	87.420	1.580	Open Manhole	1200
3.001	23.871	164.6	11	89.100	87.275	1.525	Open Manhole	1200
3.002	21.464	238.0	12	88.880	87.185	1.395	Open Manhole	1350
1.005	45.992	105.7	13	88.250	86.600	1.200	Open Manhole	1350
1.006	13.611	385.0	14	88.350	86.565	1.335	Open Manhole	1350
1.007	38.555	58.4	28	88.000	85.905	1.645	Open Manhole	1500
5.000	29.419	42.0	17	89.600	88.175	1.200	Open Manhole	1200

Caversham Bridge House  
 Waterman Place  
 Reading Berkshire RG1 8DN

Plot SGR 1  
 Bicester  
 SW Drainage Design



Date 14/03/2018 17:59

Designed by MG

File 41436\_2002\_SW\_NETWORK\_REV...

Checked by CB

Micro Drainage

Network 2017.1.2

PIPELINE SCHEDULES for Storm

Upstream Manhole

PN	Hyd Sect	Diam (mm)	MH Name	C.Level (m)	I.Level (m)	D.Depth (m)	MH Connection	MH DIAM., L*W (mm)
6.000	o	225	16	89.900	88.475	1.200	Open Manhole	1200
5.001	o	225	17	89.600	88.175	1.200	Open Manhole	1200
5.002	o	225	18	89.300	87.875	1.200	Open Manhole	1200
5.003	o	225	19	89.000	87.575	1.200	Open Manhole	1200
7.000	o	225	20	88.200	86.875	1.100	Open Manhole	1200
8.000	o	225	21	89.200	87.775	1.200	Open Manhole	1200
7.001	o	225	22	88.900	86.615	2.060	Open Manhole	1200
7.002	o	225	23	88.800	86.405	2.170	Open Manhole	1200
5.004	o	300	24	88.850	86.235	2.315	Open Manhole	1200
5.005	o	300	25	88.600	86.165	2.135	Open Manhole	1200
9.000	o	225	26	87.800	86.375	1.200	Open Manhole	1200
9.001	o	225	27	88.000	86.245	1.530	Open Manhole	1200
1.008	o	525	28	88.000	85.830	1.645	Open Manhole	1500
1.009	o	525	29	87.700	85.755	1.420	Open Manhole	1500

Downstream Manhole

PN	Length (m)	Slope (1:X)	MH Name	C.Level (m)	I.Level (m)	D.Depth (m)	MH Connection	MH DIAM., L*W (mm)
6.000	26.214	87.4	17	89.600	88.175	1.200	Open Manhole	1200
5.001	45.544	151.8	18	89.300	87.875	1.200	Open Manhole	1200
5.002	30.886	103.0	19	89.000	87.575	1.200	Open Manhole	1200
5.003	12.923	10.2	24	88.850	86.310	2.315	Open Manhole	1200
7.000	42.889	165.0	22	88.900	86.615	2.060	Open Manhole	1200
8.000	20.663	17.8	22	88.900	86.615	2.060	Open Manhole	1200
7.001	34.921	166.3	23	88.800	86.405	2.170	Open Manhole	1200
7.002	15.488	163.0	24	88.850	86.310	2.315	Open Manhole	1200
5.004	16.162	230.9	25	88.600	86.165	2.135	Open Manhole	1200
5.005	25.336	230.3	28	88.000	86.055	1.645	Open Manhole	1500
9.000	21.195	163.0	27	88.000	86.245	1.530	Open Manhole	1200
9.001	18.634	162.0	28	88.000	86.130	1.645	Open Manhole	1500
1.008	10.231	409.2	29	87.700	85.805	1.370	Open Manhole	1500
1.009	19.090	23.9	30	86.455	84.955	0.975	Open Manhole	1500

Caversham Bridge House  
 Waterman Place  
 Reading Berkshire RG1 8DN

Plot SGR 1  
 Bicester  
 SW Drainage Design



Date 14/03/2018 17:59  
 File 41436\_2002\_SW\_NETWORK\_REV...

Designed by MG  
 Checked by CB

Micro Drainage

Network 2017.1.2

PIPELINE SCHEDULES for Storm

Upstream Manhole

PN	Hyd Sect	Diam (mm)	MH Name	C.Level (m)	I.Level (m)	D.Depth (m)	MH Connection	MH DIAM., L*W (mm)
1.010	o	150	30	86.455	84.955	1.350	Open Manhole	1500
1.011	o	150	31	83.800	83.200	0.450	Open Manhole	1200

Downstream Manhole

PN	Length (m)	Slope (1:X)	MH Name	C.Level (m)	I.Level (m)	D.Depth (m)	MH Connection	MH DIAM., L*W (mm)
1.010	39.797	22.7	31	83.800	83.200	0.450	Open Manhole	1200
1.011	10.002	100.0		83.600	83.100	0.350	Open Manhole	1200

Free Flowing Outfall Details for Storm

Outfall Pipe Number	Outfall Name	C. Level (m)	I. Level (m)	Min I. Level (m)	D,L (mm)	W (mm)
1.011		83.600	83.100	83.100	1200	0

Simulation Criteria for Storm

Volumetric Runoff Coeff 0.750      Additional Flow - % of Total Flow 0.000  
 Areal Reduction Factor 1.000      MADD Factor \* 10m<sup>3</sup>/ha Storage 2.000  
 Hot Start (mins) 0      Inlet Coefficient 0.800  
 Hot Start Level (mm) 0      Flow per Person per Day (l/per/day) 0.000  
 Manhole Headloss Coeff (Global) 0.500      Run Time (mins) 60  
 Foul Sewage per hectare (l/s) 0.000      Output Interval (mins) 1

Number of Input Hydrographs 0      Number of Offline Controls 0      Number of Time/Area Diagrams 0  
 Number of Online Controls 2      Number of Storage Structures 1      Number of Real Time Controls 0

Synthetic Rainfall Details

Rainfall Model      FSR      Profile Type Summer  
 Return Period (years) 2      Cv (Summer) 0.750  
     Region England and Wales      Cv (Winter) 0.840  
     M5-60 (mm) 20.000      Storm Duration (mins) 30  
     Ratio R 0.405

Caversham Bridge House  
 Waterman Place  
 Reading Berkshire RG1 8DN

Plot SGR 1  
 Bicester  
 SW Drainage Design



Date 14/03/2018 17:59  
 File 41436\_2002\_SW\_NETWORK\_REV...

Designed by MG  
 Checked by CB

Micro Drainage

Network 2017.1.2

Online Controls for Storm

Hydro-Brake® Optimum Manhole: 30, DS/PN: 1.010, Volume (m³): 6.5

Unit Reference	MD-SHE-0103-5000-1198-5000
Design Head (m)	1.198
Design Flow (l/s)	5.0
Flush-Flo™	Calculated
Objective	Minimise upstream storage
Application	Surface
Sump Available	Yes
Diameter (mm)	103
Invert Level (m)	84.955
Minimum Outlet Pipe Diameter (mm)	150
Suggested Manhole Diameter (mm)	1200

Control Points	Head (m)	Flow (l/s)	Control Points	Head (m)	Flow (l/s)
Design Point (Calculated)	1.198	5.0	Kick-Flo®	0.744	4.0
Flush-Flo™	0.353	5.0	Mean Flow over Head Range	-	4.4

The hydrological calculations have been based on the Head/Discharge relationship for the Hydro-Brake® Optimum as specified. Should another type of control device other than a Hydro-Brake Optimum® be utilised then these storage routing calculations will be invalidated

Depth (m)	Flow (l/s)	Depth (m)	Flow (l/s)	Depth (m)	Flow (l/s)	Depth (m)	Flow (l/s)
0.100	3.4	1.200	5.0	3.000	7.7	7.000	11.5
0.200	4.7	1.400	5.4	3.500	8.3	7.500	11.9
0.300	5.0	1.600	5.7	4.000	8.8	8.000	12.2
0.400	5.0	1.800	6.0	4.500	9.3	8.500	12.6
0.500	4.9	2.000	6.3	5.000	9.8	9.000	12.9
0.600	4.7	2.200	6.6	5.500	10.2	9.500	13.3
0.800	4.1	2.400	6.9	6.000	10.7		
1.000	4.6	2.600	7.2	6.500	11.1		

Non Return Valve Manhole: 31, DS/PN: 1.011, Volume (m³): 1.4

Caversham Bridge House  
Waterman Place  
Reading Berkshire RG1 8DN

Plot SGR 1  
Bicester  
SW Drainage Design



Date 14/03/2018 17:59  
File 41436\_2002\_SW\_NETWORK\_REV...

Designed by MG  
Checked by CB

Micro Drainage

Network 2017.1.2

Storage Structures for Storm

Infiltration Basin Manhole: 30, DS/PN: 1.010

Invert Level (m) 84.955 Safety Factor 2.0  
Infiltration Coefficient Base (m/hr) 0.00000 Porosity 1.00  
Infiltration Coefficient Side (m/hr) 0.00000

Depth (m)	Area (m <sup>2</sup> )	Depth (m)	Area (m <sup>2</sup> )
0.000	288.7	1.500	918.7

Caversham Bridge House  
 Waterman Place  
 Reading Berkshire RG1 8DN

Plot SGR 1  
 Bicester  
 SW Drainage Design



Date 14/03/2018 17:59  
 File 41436\_2002\_SW\_NETWORK\_REV...

Designed by MG  
 Checked by CB

Micro Drainage

Network 2017.1.2

1 year Return Period Summary of Critical Results by Maximum Level (Rank 1) for Storm

Simulation Criteria

Areal Reduction Factor 1.000 Additional Flow - % of Total Flow 0.000  
 Hot Start (mins) 0 MADD Factor \* 10m<sup>3</sup>/ha Storage 2.000  
 Hot Start Level (mm) 0 Inlet Coefficient 0.800  
 Manhole Headloss Coeff (Global) 0.500 Flow per Person per Day (l/per/day) 0.000  
 Foul Sewage per hectare (l/s) 0.000

Number of Input Hydrographs 0 Number of Offline Controls 0 Number of Time/Area Diagrams 0  
 Number of Online Controls 2 Number of Storage Structures 1 Number of Real Time Controls 0

Synthetic Rainfall Details

Rainfall Model FSR Ratio R 0.405  
 Region England and Wales Cv (Summer) 0.750  
 M5-60 (mm) 20.000 Cv (Winter) 0.840

Margin for Flood Risk Warning (mm) 300.0 DVD Status OFF  
 Analysis Timestep Fine Inertia Status OFF  
 DTS Status ON

Profile(s)

Duration(s) (mins) 15, 30, 60, 120, 240, 360, 480, 960, 1440  
 Return Period(s) (years) 1, 30, 100  
 Climate Change (%) 0, 0, 30

PN	US/MH Name	Storm	Return Period	Climate Change	First (X) Surcharge	First (Y) Flood	First (Z) Overflow	Overflow Act.	Water Level (m)
1.000	1	15 Winter	1	+0%					88.928
2.000	2	15 Summer	1	+0%					88.904
1.001	3	15 Winter	1	+0%	100/15 Summer				88.699
1.002	4	15 Winter	1	+0%	100/15 Summer				88.267
1.003	5	15 Winter	1	+0%	100/15 Summer				87.824
1.004	6	15 Winter	1	+0%	100/15 Summer				87.706
3.000	7	15 Summer	1	+0%					88.084
4.000	8	15 Winter	1	+0%	100/15 Summer				87.886
4.001	9	15 Winter	1	+0%	100/15 Summer				87.709
3.001	10	15 Winter	1	+0%	100/15 Summer				87.539
3.002	11	15 Winter	1	+0%	30/15 Summer				87.417
1.005	12	15 Winter	1	+0%	100/15 Summer				87.179
1.006	13	15 Winter	1	+0%	30/15 Summer				86.855
1.007	14	15 Winter	1	+0%					86.694
5.000	15	15 Summer	1	+0%					88.915
6.000	16	15 Winter	1	+0%	100/15 Summer				88.500
5.001	17	15 Winter	1	+0%	100/15 Summer				88.258
5.002	18	15 Winter	1	+0%	100/15 Summer				87.971
5.003	19	15 Winter	1	+0%	100/15 Winter				87.634
7.000	20	15 Winter	1	+0%	100/15 Summer				86.938
8.000	21	15 Winter	1	+0%					87.800
7.001	22	15 Winter	1	+0%	30/15 Summer				86.706
7.002	23	15 Winter	1	+0%	30/15 Summer				86.515
5.004	24	15 Winter	1	+0%	30/15 Summer				86.410
5.005	25	15 Winter	1	+0%	30/15 Summer				86.340

Caversham Bridge House  
 Waterman Place  
 Reading Berkshire RG1 8DN

Plot SGR 1  
 Bicester  
 SW Drainage Design



Date 14/03/2018 17:59  
 File 41436\_2002\_SW\_NETWORK\_REV...

Designed by MG  
 Checked by CB

Micro Drainage

Network 2017.1.2

1 year Return Period Summary of Critical Results by Maximum Level (Rank 1) for Storm

PN	US/MH Name	Depth (m)	Surcharged Flooded		Pipe Flow (l/s)	Level Exceeded	Status
			Volume (m <sup>3</sup> )	Flow / Overflow Cap. (l/s)			
1.000	1	-0.172	0.000	0.12	4.6	OK	
2.000	2	-0.196	0.000	0.04	2.1	OK	
1.001	3	-0.156	0.000	0.20	13.4	OK	
1.002	4	-0.133	0.000	0.35	17.2	OK	
1.003	5	-0.176	0.000	0.36	23.6	OK	
1.004	6	-0.194	0.000	0.27	30.5	OK	
3.000	7	-0.216	0.000	0.01	0.7	OK	
4.000	8	-0.214	0.000	0.18	16.0	OK	
4.001	9	-0.191	0.000	0.28	21.9	OK	
3.001	10	-0.181	0.000	0.33	25.4	OK	
3.002	11	-0.158	0.000	0.45	28.5	OK	
1.005	12	-0.306	0.000	0.22	63.4	OK	
1.006	13	-0.195	0.000	0.61	65.8	OK	
1.007	14	-0.321	0.000	0.18	68.6	OK	
5.000	15	-0.185	0.000	0.07	5.5	OK	
6.000	16	-0.200	0.000	0.03	1.5	OK	
5.001	17	-0.142	0.000	0.28	11.3	OK	
5.002	18	-0.129	0.000	0.38	18.1	OK	
5.003	19	-0.166	0.000	0.15	21.6	OK	
7.000	20	-0.162	0.000	0.17	6.5	OK	
8.000	21	-0.200	0.000	0.03	3.3	OK	
7.001	22	-0.134	0.000	0.33	12.7	OK	
7.002	23	-0.115	0.000	0.48	17.1	OK	
5.004	24	-0.125	0.000	0.63	39.0	OK	
5.005	25	-0.125	0.000	0.64	41.5	OK	

Caversham Bridge House  
 Waterman Place  
 Reading Berkshire RG1 8DN

Plot SGR 1  
 Bicester  
 SW Drainage Design



Date 14/03/2018 17:59  
 File 41436\_2002\_SW\_NETWORK\_REV...

Designed by MG  
 Checked by CB

Micro Drainage

Network 2017.1.2

1 year Return Period Summary of Critical Results by Maximum Level (Rank 1) for Storm

PN	US/MH Name	Storm	Return Period	Climate Change	First (X) Surcharge	First (Y) Flood	First (Z) Overflow	Overflow Act.	Water Level (m)
9.000	26	15	Winter	1	+0%	100/15	Summer		86.440
9.001	27	15	Winter	1	+0%	30/15	Summer		86.321
1.008	28	15	Winter	1	+0%	30/15	Summer		86.211
1.009	29	15	Winter	1	+0%				85.902
1.010	30	240	Winter	1	+0%	1/15	Summer		85.296
1.011	31	360	Winter	1	+0%				83.258

PN	US/MH Name	Surcharged Depth (m)	Flooded Volume (m³)	Flow / Cap.	Overflow (l/s)	Pipe Flow (l/s)	Status	Level Exceeded
9.000	26	-0.160	0.000	0.19		6.9	OK	
9.001	27	-0.149	0.000	0.24		9.0	OK	
1.008	28	-0.144	0.000	0.88		119.1	OK	
1.009	29	-0.378	0.000	0.17		118.5	OK	
1.010	30	0.191	0.000	0.14		5.0	SURCHARGED	
1.011	31	-0.092	0.000	0.32		5.0	OK	



Caversham Bridge House  
 Waterman Place  
 Reading Berkshire RG1 8DN

Plot SGR 1  
 Bicester  
 SW Drainage Design



Date 14/03/2018 17:59  
 File 41436\_2002\_SW\_NETWORK\_REV...

Designed by MG  
 Checked by CB

Micro Drainage

Network 2017.1.2

30 year Return Period Summary of Critical Results by Maximum Level (Rank 1) for Storm

Simulation Criteria

Areal Reduction Factor 1.000 Additional Flow - % of Total Flow 0.000  
 Hot Start (mins) 0 MADD Factor \* 10m<sup>3</sup>/ha Storage 2.000  
 Hot Start Level (mm) 0 Inlet Coefficient 0.800  
 Manhole Headloss Coeff (Global) 0.500 Flow per Person per Day (l/per/day) 0.000  
 Foul Sewage per hectare (l/s) 0.000

Number of Input Hydrographs 0 Number of Offline Controls 0 Number of Time/Area Diagrams 0  
 Number of Online Controls 2 Number of Storage Structures 1 Number of Real Time Controls 0

Synthetic Rainfall Details

Rainfall Model FSR Ratio R 0.405  
 Region England and Wales Cv (Summer) 0.750  
 M5-60 (mm) 20.000 Cv (Winter) 0.840

Margin for Flood Risk Warning (mm) 300.0 DVD Status OFF  
 Analysis Timestep Fine Inertia Status OFF  
 DTS Status ON

Profile(s)

Duration(s) (mins) 15, 30, 60, 120, 240, 360, 480, 960, 1440  
 Return Period(s) (years) 1, 30, 100  
 Climate Change (%) 0, 0, 30

PN	US/MH Name	Storm	Return Period	Climate Change	First (X) Surcharge	First (Y) Flood	First (Z) Overflow	Overflow Act.	Water Level (m)
1.000	1	15 Winter	30	+0%					88.960
2.000	2	15 Winter	30	+0%					88.922
1.001	3	15 Winter	30	+0%	100/15 Summer				88.750
1.002	4	15 Winter	30	+0%	100/15 Summer				88.354
1.003	5	15 Winter	30	+0%	100/15 Summer				87.957
1.004	6	15 Winter	30	+0%	100/15 Summer				87.799
3.000	7	15 Summer	30	+0%					88.097
4.000	8	15 Winter	30	+0%	100/15 Summer				87.941
4.001	9	15 Winter	30	+0%	100/15 Summer				87.794
3.001	10	15 Winter	30	+0%	100/15 Summer				87.685
3.002	11	15 Winter	30	+0%	30/15 Summer				87.587
1.005	12	15 Winter	30	+0%	100/15 Summer				87.285
1.006	13	15 Winter	30	+0%	30/15 Summer				87.084
1.007	14	15 Winter	30	+0%					86.783
5.000	15	15 Winter	30	+0%					88.939
6.000	16	15 Winter	30	+0%	100/15 Summer				88.514
5.001	17	15 Winter	30	+0%	100/15 Summer				88.326
5.002	18	15 Winter	30	+0%	100/15 Summer				88.094
5.003	19	15 Winter	30	+0%	100/15 Winter				87.676
7.000	20	15 Winter	30	+0%	100/15 Summer				87.017
8.000	21	15 Winter	30	+0%					87.814
7.001	22	15 Winter	30	+0%	30/15 Summer				86.982
7.002	23	15 Winter	30	+0%	30/15 Summer				86.915
5.004	24	15 Winter	30	+0%	30/15 Summer				86.841
5.005	25	15 Winter	30	+0%	30/15 Summer				86.696

Caversham Bridge House  
 Waterman Place  
 Reading Berkshire RG1 8DN

Plot SGR 1  
 Bicester  
 SW Drainage Design



Date 14/03/2018 17:59

Designed by MG

File 41436\_2002\_SW\_NETWORK\_REV...

Checked by CB

Micro Drainage

Network 2017.1.2

30 year Return Period Summary of Critical Results by Maximum Level (Rank 1) for Storm

PN	US/MH Name	Surcharged Flooded		Pipe		Status	Level Exceeded
		Depth (m)	Volume (m <sup>3</sup> )	Flow / Cap.	Overflow (l/s)		
1.000	1	-0.140	0.000	0.30		11.4	OK
2.000	2	-0.178	0.000	0.10		5.1	OK
1.001	3	-0.105	0.000	0.55		37.2	OK
1.002	4	-0.046	0.000	0.96		47.7	OK
1.003	5	-0.043	0.000	1.00		66.1	OK
1.004	6	-0.101	0.000	0.76		86.7	OK
3.000	7	-0.203	0.000	0.02		1.8	OK
4.000	8	-0.159	0.000	0.45		39.2	OK
4.001	9	-0.106	0.000	0.73		57.0	OK
3.001	10	-0.035	0.000	0.81		62.3	OK
3.002	11	0.012	0.000	1.12		70.5	SURCHARGED
1.005	12	-0.200	0.000	0.59		166.0	OK
1.006	13	0.034	0.000	1.56		169.4	SURCHARGED
1.007	14	-0.232	0.000	0.47		176.2	OK
5.000	15	-0.161	0.000	0.18		13.6	OK
6.000	16	-0.186	0.000	0.07		3.7	OK
5.001	17	-0.074	0.000	0.75		30.3	OK
5.002	18	-0.006	0.000	1.00		47.8	OK
5.003	19	-0.124	0.000	0.41		57.8	OK
7.000	20	-0.083	0.000	0.42		16.0	OK
8.000	21	-0.186	0.000	0.07		8.1	OK
7.001	22	0.142	0.000	0.68		25.6	SURCHARGED
7.002	23	0.285	0.000	1.04		37.1	SURCHARGED
5.004	24	0.306	0.000	1.43		88.3	SURCHARGED
5.005	25	0.231	0.000	1.45		94.9	SURCHARGED

Caversham Bridge House  
 Waterman Place  
 Reading Berkshire RG1 8DN

Plot SGR 1  
 Bicester  
 SW Drainage Design



Date 14/03/2018 17:59  
 File 41436\_2002\_SW\_NETWORK\_REV...

Designed by MG  
 Checked by CB

Micro Drainage

Network 2017.1.2

30 year Return Period Summary of Critical Results by Maximum Level (Rank 1) for Storm

PN	US/MH Name	Storm	Return Period	Climate Change	First (X) Surcharge	First (Y) Flood	First (Z) Overflow	Overflow Act.	Water Level (m)
9.000	26	15 Winter	30	+0%	100/15 Summer				86.522
9.001	27	15 Winter	30	+0%	30/15 Summer				86.493
1.008	28	15 Winter	30	+0%	30/15 Summer				86.457
1.009	29	15 Winter	30	+0%					85.996
1.010	30	480 Winter	30	+0%	1/15 Summer				85.738
1.011	31	960 Winter	30	+0%					83.258

PN	US/MH Name	Surcharged Depth (m)	Flooded Volume (m³)	Flow / Overflow Cap. (l/s)	Pipe Flow (l/s)	Status	Level Exceeded
9.000	26	-0.078	0.000	0.46	16.8	OK	
9.001	27	0.023	0.000	0.60	22.0	SURCHARGED	
1.008	28	0.102	0.000	2.19	297.9	SURCHARGED	
1.009	29	-0.284	0.000	0.43	296.7	OK	
1.010	30	0.633	0.000	0.14	5.0	SURCHARGED	
1.011	31	-0.092	0.000	0.32	5.0	OK	

Caversham Bridge House  
 Waterman Place  
 Reading Berkshire RG1 8DN

Plot SGR 1  
 Bicester  
 SW Drainage Design



Date 14/03/2018 17:59

Designed by MG

File 41436\_2002\_SW\_NETWORK\_REV...

Checked by CB

Micro Drainage

Network 2017.1.2

100 year Return Period Summary of Critical Results by Maximum Level (Rank 1) for Storm

Simulation Criteria

Areal Reduction Factor 1.000 Additional Flow - % of Total Flow 0.000  
 Hot Start (mins) 0 MADD Factor \* 10m<sup>3</sup>/ha Storage 2.000  
 Hot Start Level (mm) 0 Inlet Coefficient 0.800  
 Manhole Headloss Coeff (Global) 0.500 Flow per Person per Day (l/per/day) 0.000  
 Foul Sewage per hectare (l/s) 0.000

Number of Input Hydrographs 0 Number of Offline Controls 0 Number of Time/Area Diagrams 0  
 Number of Online Controls 2 Number of Storage Structures 1 Number of Real Time Controls 0

Synthetic Rainfall Details

Rainfall Model FSR Ratio R 0.405  
 Region England and Wales Cv (Summer) 0.750  
 M5-60 (mm) 20.000 Cv (Winter) 0.840

Margin for Flood Risk Warning (mm) 300.0 DVD Status OFF  
 Analysis Timestep Fine Inertia Status OFF  
 DTS Status ON

Profile(s)

Duration(s) (mins) 15, 30, 60, 120, 240, 360, 480, 960, 1440  
 Return Period(s) (years) 1, 30, 100  
 Climate Change (%) 0, 0, 30

PN	US/MH Name	Storm	Return Period	Climate Change	First (X) Surcharge	First (Y) Flood	First (Z) Overflow	Overflow Act.	Water Level (m)
1.000	1	15 Winter	100	+30%					89.074
2.000	2	15 Winter	100	+30%					89.041
1.001	3	15 Winter	100	+30%	100/15 Summer				89.028
1.002	4	15 Winter	100	+30%	100/15 Summer				88.802
1.003	5	15 Winter	100	+30%	100/15 Summer				88.158
1.004	6	15 Winter	100	+30%	100/15 Summer				87.977
3.000	7	15 Winter	100	+30%					88.102
4.000	8	15 Winter	100	+30%	100/15 Summer				88.300
4.001	9	15 Winter	100	+30%	100/15 Summer				88.221
3.001	10	15 Winter	100	+30%	100/15 Summer				88.026
3.002	11	15 Winter	100	+30%	30/15 Summer				87.795
1.005	12	15 Winter	100	+30%	100/15 Summer				87.515
1.006	13	15 Winter	100	+30%	30/15 Summer				87.197
1.007	14	15 Winter	100	+30%					86.961
5.000	15	15 Winter	100	+30%					88.960
6.000	16	15 Winter	100	+30%	100/15 Summer				88.774
5.001	17	15 Winter	100	+30%	100/15 Summer				88.764
5.002	18	15 Winter	100	+30%	100/15 Summer				88.445
5.003	19	15 Winter	100	+30%	100/15 Winter				87.848
7.000	20	15 Winter	100	+30%	100/15 Summer				87.944
8.000	21	15 Winter	100	+30%					87.893
7.001	22	15 Winter	100	+30%	30/15 Summer				87.875
7.002	23	15 Winter	100	+30%	30/15 Summer				87.674
5.004	24	15 Winter	100	+30%	30/15 Summer				87.469
5.005	25	15 Winter	100	+30%	30/15 Summer				87.153

Caversham Bridge House  
 Waterman Place  
 Reading Berkshire RG1 8DN

Plot SGR 1  
 Bicester  
 SW Drainage Design



Date 14/03/2018 17:59  
 File 41436\_2002\_SW\_NETWORK\_REV...

Designed by MG  
 Checked by CB

Micro Drainage

Network 2017.1.2

100 year Return Period Summary of Critical Results by Maximum Level (Rank 1) for Storm

PN	US/MH Name	Surcharged Flooded		Flow / Overflow		Pipe	Status	Level Exceeded
		Depth (m)	Volume (m <sup>3</sup> )	Cap.	(l/s)	Flow (l/s)		
1.000	1	-0.026	0.000	0.50		19.1	OK	
2.000	2	-0.059	0.000	0.16		8.4	OK	
1.001	3	0.173	0.000	0.73		48.8	SURCHARGED	
1.002	4	0.402	0.000	1.26		62.6	SURCHARGED	
1.003	5	0.158	0.000	1.36		89.8	SURCHARGED	
1.004	6	0.077	0.000	1.07		122.4	SURCHARGED	
3.000	7	-0.198	0.000	0.04		3.1	OK	
4.000	8	0.200	0.000	0.68		59.3	SURCHARGED	
4.001	9	0.321	0.000	1.07		83.9	SURCHARGED	
3.001	10	0.306	0.000	1.26		96.6	SURCHARGED	
3.002	11	0.220	0.000	1.72		108.7	SURCHARGED	
1.005	12	0.030	0.000	0.86		243.1	SURCHARGED	
1.006	13	0.147	0.000	2.33		252.6	SURCHARGED	
1.007	14	-0.054	0.000	0.70		262.3	OK	
5.000	15	-0.140	0.000	0.31		22.9	OK	
6.000	16	0.074	0.000	0.11		5.8	SURCHARGED	
5.001	17	0.364	0.000	1.02		40.9	SURCHARGED	
5.002	18	0.345	0.000	1.42		68.2	SURCHARGED	
5.003	19	0.048	0.000	0.56		78.6	SURCHARGED	
7.000	20	0.844	0.000	0.48		18.6	FLOOD RISK	
8.000	21	-0.107	0.000	0.12		13.6	OK	
7.001	22	1.035	0.000	0.98		37.0	SURCHARGED	
7.002	23	1.044	0.000	1.48		53.0	SURCHARGED	
5.004	24	0.934	0.000	2.12		130.9	SURCHARGED	
5.005	25	0.688	0.000	2.15		140.0	SURCHARGED	

Caversham Bridge House  
 Waterman Place  
 Reading Berkshire RG1 8DN

Plot SGR 1  
 Bicester  
 SW Drainage Design



Date 14/03/2018 17:59  
 File 41436\_2002\_SW\_NETWORK\_REV...

Designed by MG  
 Checked by CB

Micro Drainage

Network 2017.1.2

100 year Return Period Summary of Critical Results by Maximum Level (Rank 1) for Storm

PN	US/MH Name	Storm	Return Period	Climate Change	First (X) Surcharge	First (Y) Flood	First (Z) Overflow	Overflow Act.	Water Level (m)
9.000	26	15 Winter	100	+30%	100/15 Summer				86.772
9.001	27	15 Winter	100	+30%	30/15 Summer				86.720
1.008	28	15 Winter	100	+30%	30/15 Summer				86.638
1.009	29	480 Winter	100	+30%					86.155
1.010	30	480 Winter	100	+30%	1/15 Summer				86.153
1.011	31	480 Winter	100	+30%					83.258

PN	US/MH Name	Surcharged Depth (m)	Flooded Volume (m³)	Flow / Overflow Cap. (l/s)	Pipe Flow (l/s)	Status	Level Exceeded
9.000	26	0.172	0.000	0.66	24.6	SURCHARGED	
9.001	27	0.250	0.000	0.94	34.4	SURCHARGED	
1.008	28	0.283	0.000	3.24	439.8	SURCHARGED	
1.009	29	-0.125	0.000	0.09	64.2	OK	
1.010	30	1.048	0.000	0.14	5.0	SURCHARGED	
1.011	31	-0.092	0.000	0.32	5.0	OK	