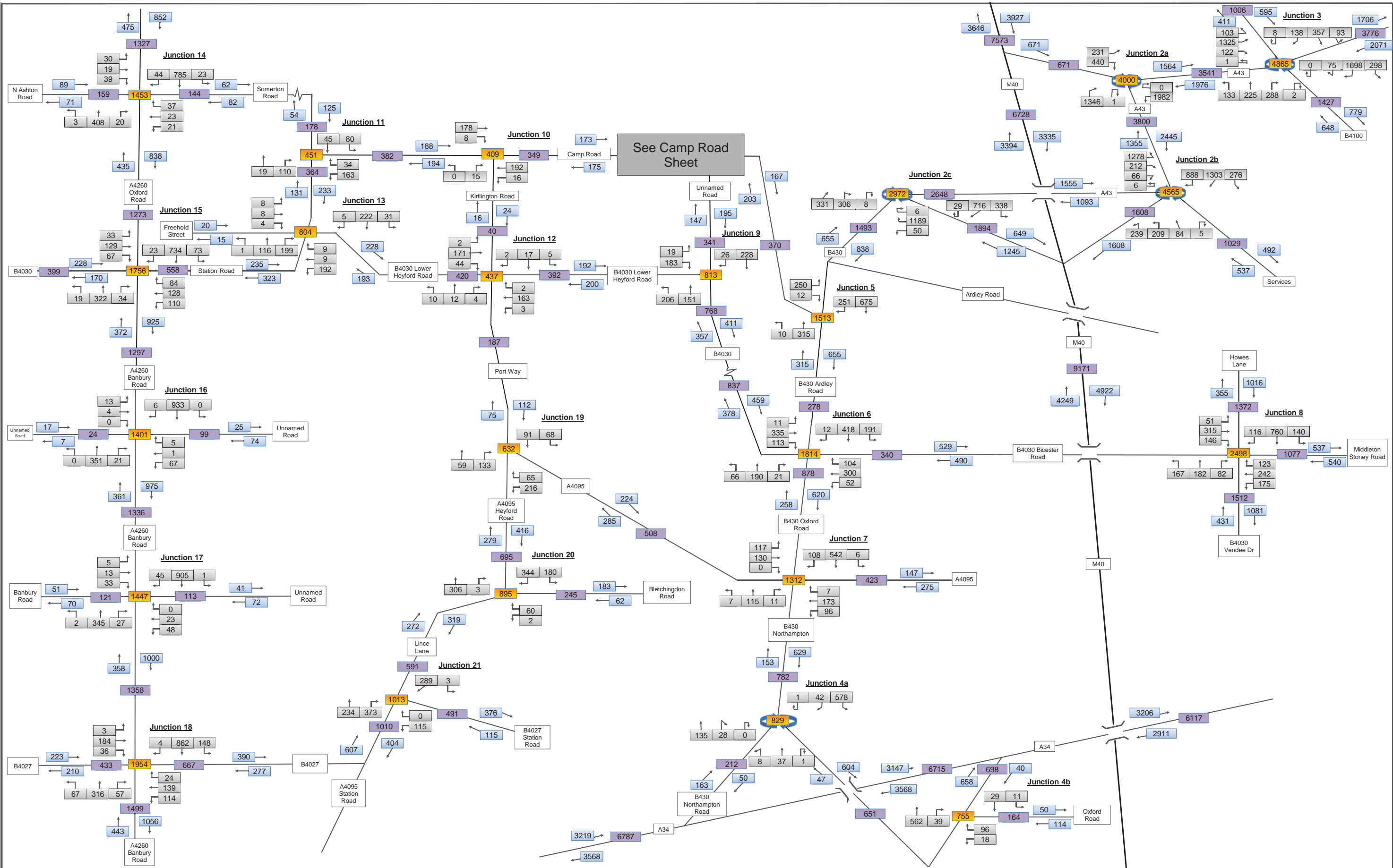

Figure 11.4



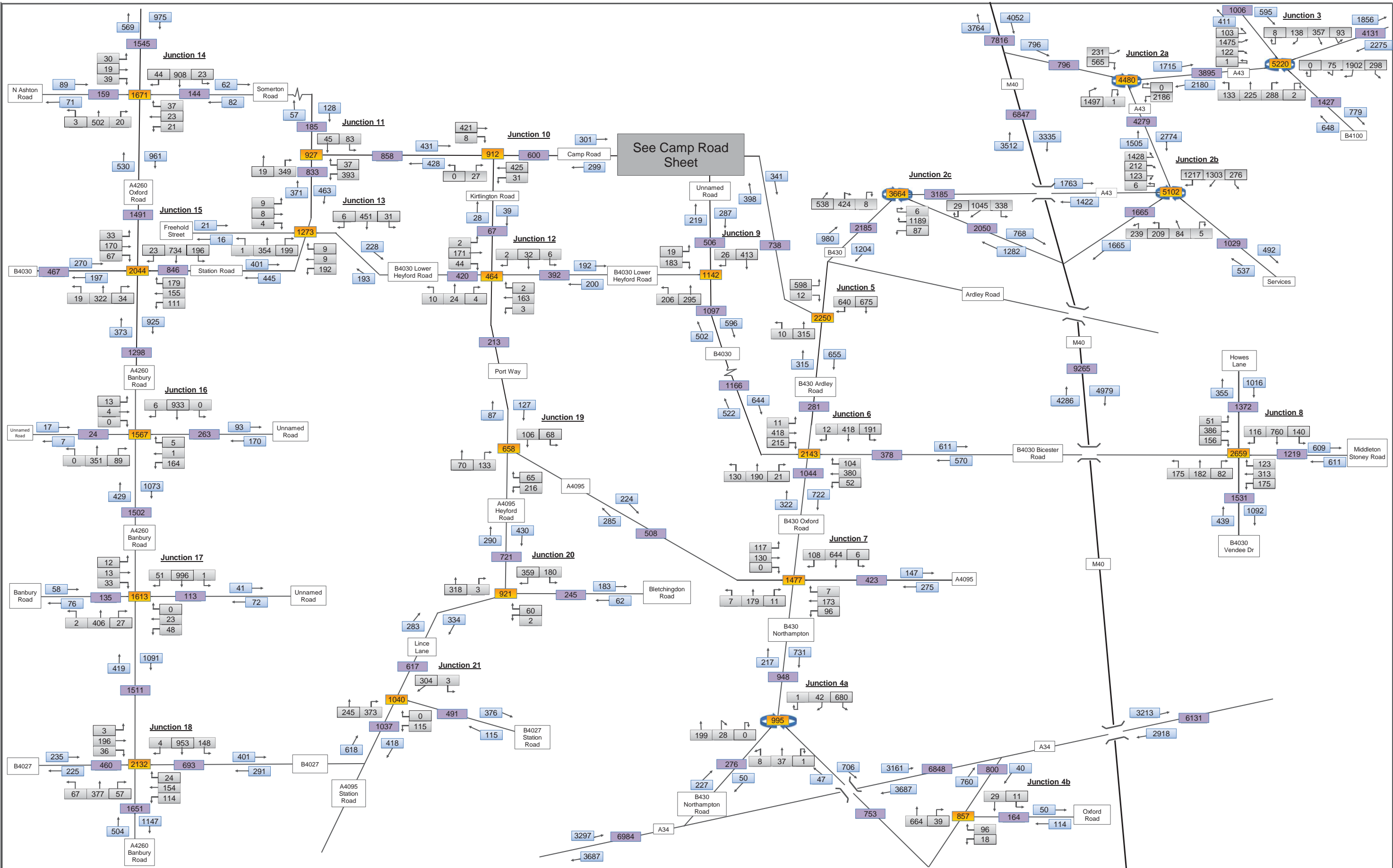













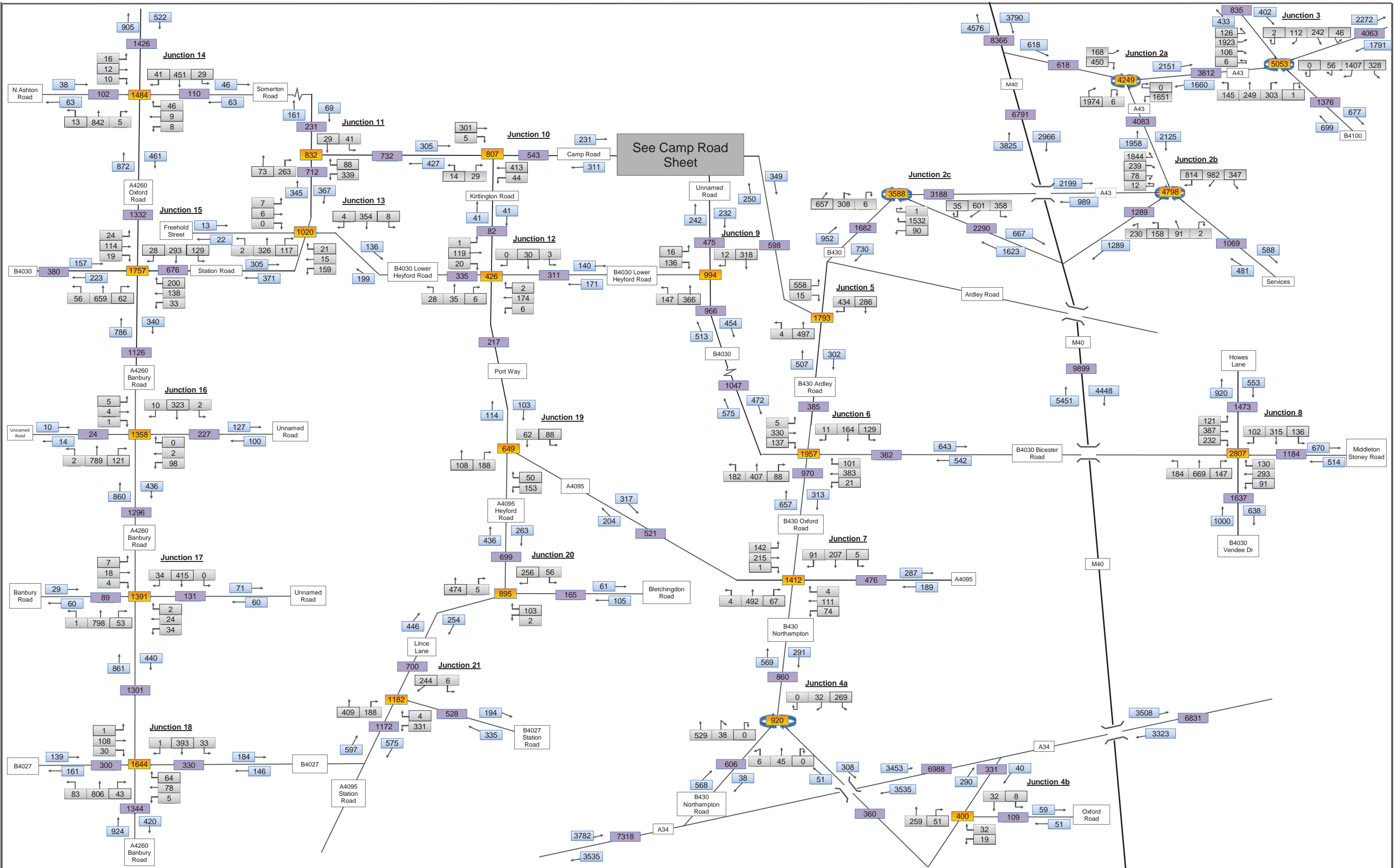

Figure 11.8





# Drawings



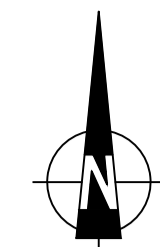

NOTES:

1. THE LAYOUT IS SUBJECT TO DETAILED DESIGN, ROAD SAFETY AUDIT, CAPACITY TESTING, GROUND INVESTIGATIONS RESULTS & EARTHWORKS MODELLING, UTILITIES & SERVICES AND CONFIRMATION OF LAND OWNERSHIP;
2. THE DETAILED DESIGN LAYOUT WILL BE DESIGNED IN ACCORDANCE WITH ALL RELEVANT DESIGN GUIDANCE AND STANDARDS;
3. THE LAYOUT HAS BEEN BASED ON THE APPROPRIATE DESIGN SPEED FOR OUR CURRENT PROPOSALS;
4. THIS DRAWING SHOULD BE READ IN CONJUNCTION WITH ALL RELEVANT ASSOCIATED DOCUMENTS; AND
5. THE USE OF THE DRAWING DOES NOT ABSOLVE THE CLIENT FROM THEIR RESPONSIBILITIES IN REGARDS TO HEALTH & SAFETY AND CDM REGULATIONS;

KEY:

- HIGHWAY BOUNDARY INFORMATION RECEIVED FROM OXFORD COUNTY COUNCIL ON 13.03.17 AND INTERPRETED BY PBA
- 215M STOPPING SIGHT DISTANCE TO ROUNDABOUT GIVE-WAY LINE IN ACCORDANCE WITH DMRB FOR A 60MPH ROAD
- 81M MAXIMUM ACHIEVABLE STOPPING SIGHT DISTANCE TO ROUNDABOUT GIVE-WAY LINE DUE TO ADOPTED HIGHWAY CONSTRAINT

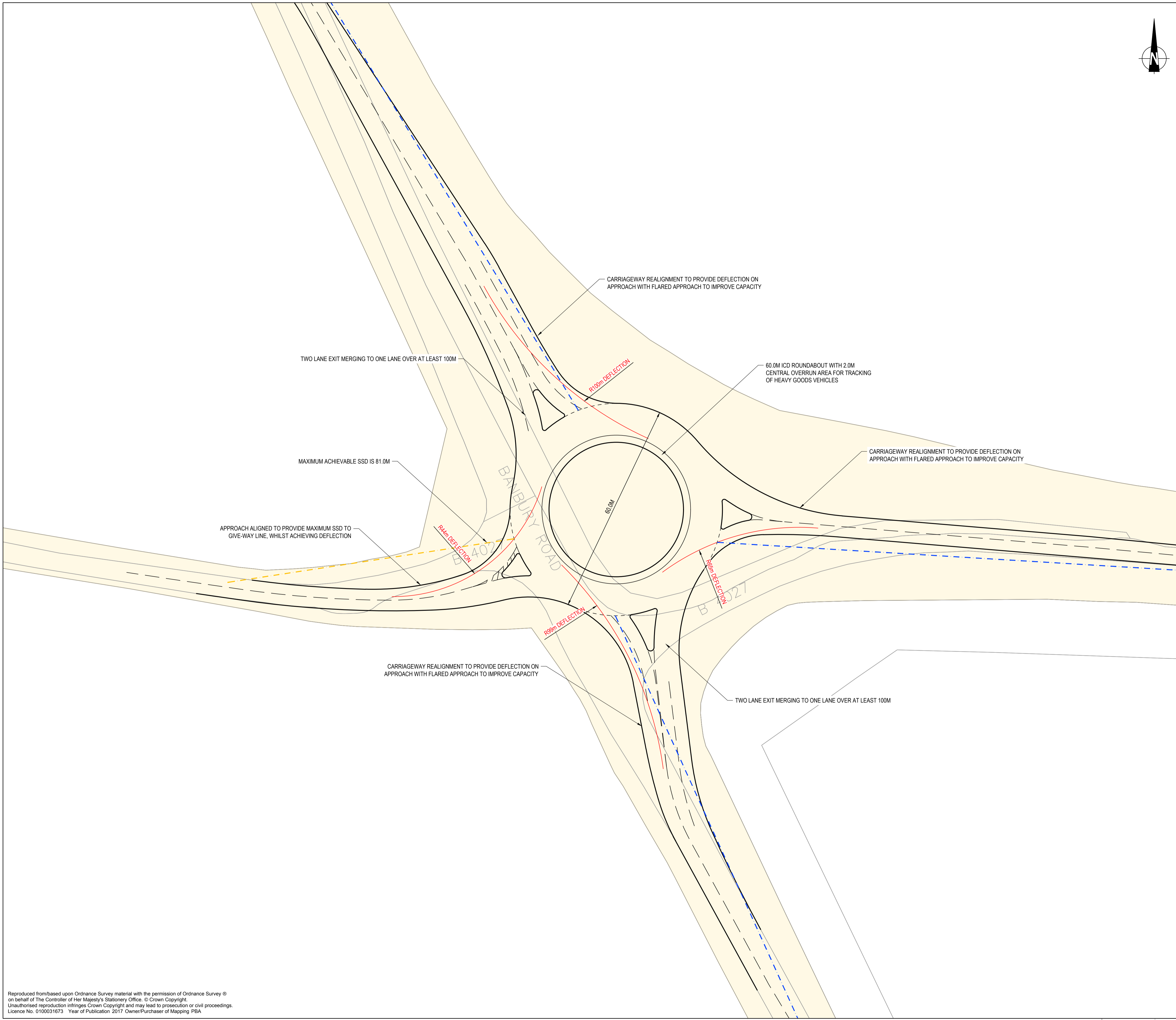

Mark	Revision	Date	Drawn	Chkd	Appd
A	2M OVERRUN PROVIDED FOR HGV	15.03.18	PC	PR	MW

SCALING NOTE: Do not scale from this drawing. If in doubt, ask.  
 UTILITIES NOTE: The position of any existing public or private sewers, utility services, plant or apparatus shown on this drawing is believed to be correct, but no warranty to this is expressed or implied. Other such plant or apparatus may also be present but not shown. The Contractor is therefore advised to undertake their own investigation where the presence of any existing sewers, services, plant or apparatus may affect their operations.

Drawing Issue Status: **FOR DISCUSSION**

HEYFORD PARK, TRANCHE 2  
 CONCEPT ROUNDABOUT (J18)  
 POTENTIAL MITIGATION SCHEME

Client <b>DORCHESTER GROUP</b>			 Offices throughout the UK and Europe <b>www.peterbrett.com</b> © Peter Brett Associates LLP BRISTOL Tel: 01173 327 840
Date of 1st Issue 09.05.2017	Designed JDS	Drawn JDS	
A1 Scale 1:500	Checked PC	Approved -	
Drawing Number <b>39304/101/SK01</b>	Revision <b>A</b>		

Reproduced from/based upon Ordnance Survey material with the permission of Ordnance Survey © on behalf of The Controller of Her Majesty's Stationery Office. © Crown Copyright. Unauthorised reproduction infringes Crown Copyright and may lead to prosecution or civil proceedings. Licence No. 0100031673 Year of Publication: 2017 Owner/Purchaser of Mapping: PBA





- NOTES:
1. THE LAYOUT IS SUBJECT TO DETAILED DESIGN, ROAD SAFETY AUDIT, CAPACITY TESTING, GROUND INVESTIGATIONS RESULTS & EARTHWORKS MODELLING, UTILITIES & SERVICES AND CONFIRMATION OF LAND OWNERSHIP;
  2. THE DETAILED DESIGN LAYOUT WILL BE DESIGNED IN ACCORDANCE WITH ALL RELEVANT DESIGN GUIDANCE AND STANDARDS;
  3. THE LAYOUT HAS BEEN BASED ON THE APPROPRIATE DESIGN SPEED FOR OUR CURRENT PROPOSALS;
  4. THIS DRAWING SHOULD BE READ IN CONJUNCTION WITH ALL RELEVANT ASSOCIATED DOCUMENTS; AND
  5. THE USE OF THE DRAWING DOES NOT ABSOLVE THE CLIENT FROM THEIR RESPONSIBILITIES IN REGARDS TO HEALTH & SAFETY AND CDM REGULATIONS;
  6. EXISTING ROAD MARKINGS HAVE BEEN DRAWN INDICATIVELY

- KEY:
- HIGHWAY BOUNDARY INFORMATION RECEIVED FROM OXFORD COUNTY COUNCIL ON 13.03.17 AND INTERPRETED BY PBA
  - 215M STOPPING SIGHT DISTANCE TO JUNCTION NEAR-SIDE SIGNAL HEAD IN ACCORDANCE WITH DMRB FOR A 60MPH ROAD
  - STOPPING SIGHT DISTANCE (MAXIMUM ACHIEVABLE) TO JUNCTION NEAR-SIDE SIGNAL HEAD WITHIN ADOPTED HIGHWAY LAND
  - STOPPING SIGHT DISTANCE (MAXIMUM ACHIEVABLE) TO JUNCTION OFF-SIDE SIGNAL HEAD WITHIN ADOPTED HIGHWAY LAND
  - JUNCTION INTERVISIBILITY TO DMRB
  - RELOCATED PRIMARY TRAFFIC SIGNAL HEAD AND POLE
  - EXISTING PRIMARY TRAFFIC SIGNAL HEAD AND POLE
  - EXISTING SECONDARY TRAFFIC SIGNAL HEAD AND POLE

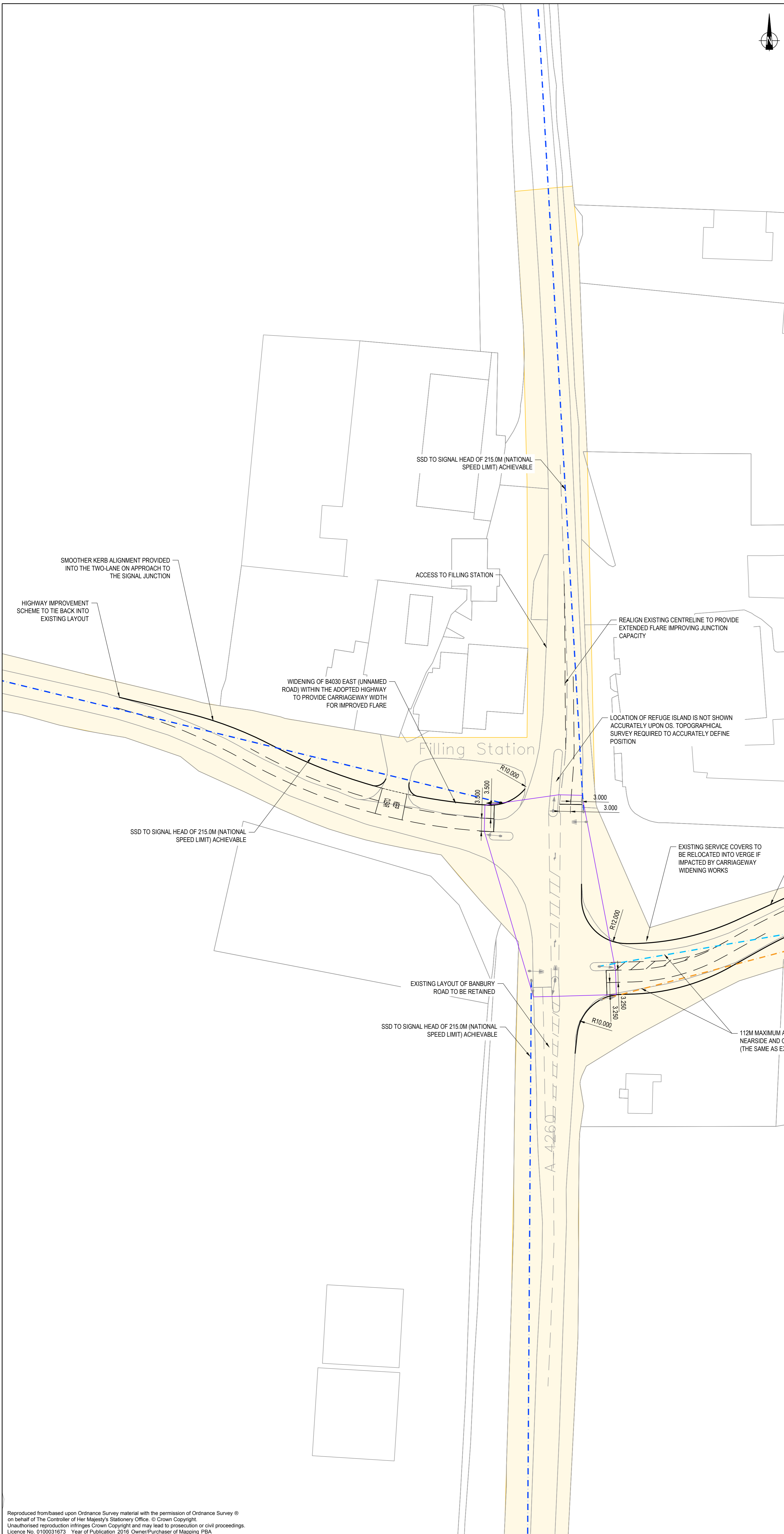
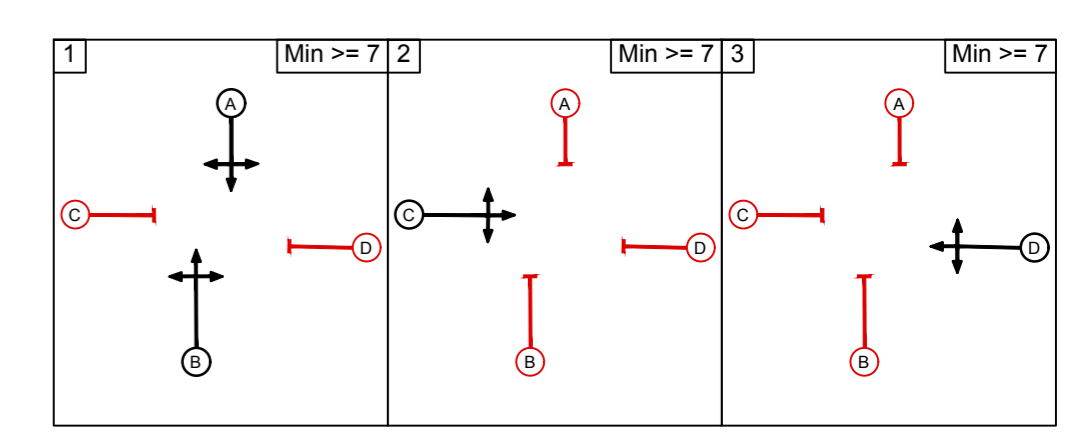

Mark	Revision	Date	Drawn	Chkd	Appd
F	ADDITIONAL ANNOTATIONS SHOWN IN RESPONSE TO RSA	15.03.18	PC	PR	MW
E	REVISED FOLLOWING STAGE 1 RSA COMMENTS	06.03.18	JDS	PR	-
D	ANNOTATION TO SERVICE STATION REMOVED	08.12.17	PC	PC	-
C	ADDED SIGNAL HEADS AND STAGE DIAGRAM	06.12.17	LB	PC	-
B	REVISION TO FILLING STATION ACCESS TIE IN	15.11.17	LB	PC	-
A	REVISION TO FLARE LENGTH AND ROAD MARKINGS	18.08.17	JHo	PR	-

SCALING NOTE: Do not scale from this drawing. If in doubt, ask.  
 UTILITIES NOTE: The position of any existing public or private sewers, utility services, plant or apparatus shown on this drawing is believed to be correct, but no warranty to this is expressed or implied. Other such plant or apparatus may also be present but not shown. The Contractor is therefore advised to undertake his own investigation where the presence of any existing sewers, services, plant or apparatus may affect his operations.

Drawing Issue Status  
**FOR DISCUSSION**

**HEYFORD PARK, TRANCHE 2**  
**HOPCROFTS HOLT JUNCTION (J15)**  
**POTENTIAL MITIGATION SCHEMES**

Client  
**DORCHESTER GROUP**



Date of 1st Issue	08.05.2017	Designed	JDS	Drawn	JDS
A1 Scale	1:500	Checked	-	Approved	-
Drawing Number	39304/5501/SK03	Revision	F		







Reproduced from/based upon Ordnance Survey material with the permission of Ordnance Survey © on behalf of The Controller of Her Majesty's Stationery Office. © Crown Copyright. Unauthorised reproduction infringes Crown Copyright and may lead to prosecution or civil proceedings. Licence No. 0100031673 Year of Publication: 2016 Owner/Purchaser of Mapping PBA



**NOTES:**

1. THE LAYOUT IS SUBJECT TO DETAILED DESIGN, ROAD SAFETY AUDIT, CAPACITY TESTING, GROUND INVESTIGATIONS RESULTS & EARTHWORKS MODELLING, UTILITIES & SERVICES AND CONFIRMATION OF LAND OWNERSHIP;
2. THE DETAILED DESIGN LAYOUT WILL BE DESIGNED IN ACCORDANCE WITH ALL RELEVANT DESIGN GUIDANCE AND STANDARDS;
3. THE LAYOUT HAS BEEN BASED ON THE APPROPRIATE DESIGN SPEED FOR OUR CURRENT PROPOSALS;
4. THIS DRAWING SHOULD BE READ IN CONJUNCTION WITH ALL RELEVANT ASSOCIATED DOCUMENTS; AND
5. THE USE OF THE DRAWING DOES NOT ABSOLVE THE CLIENT FROM THEIR RESPONSIBILITIES IN REGARDS TO HEALTH & SAFETY AND CDM REGULATIONS;

**KEY:**

-  HIGHWAY BOUNDARY INFORMATION RECEIVED FROM OXFORD COUNTY COUNCIL ON 13.03.17 AND INTERPRETED BY PBA
-  LAND UNDER THE CLIENT'S CONTROL. LAND TITLE ON288089 (UPPER HEYFORD GP LTD)
-  215M STOPPING SIGHT DISTANCE TO JUNCTION GIVE-WAY LINE IN ACCORDANCE WITH DMRB FOR A 60MPH ROAD
-  JUNCTION INTERVISIBILITY IN ACCORDANCE WITH DMRB
-  PRIMARY TRAFFIC SIGNAL HEAD AND POLE
-  SECONDARY TRAFFIC SIGNAL HEAD AND POLE

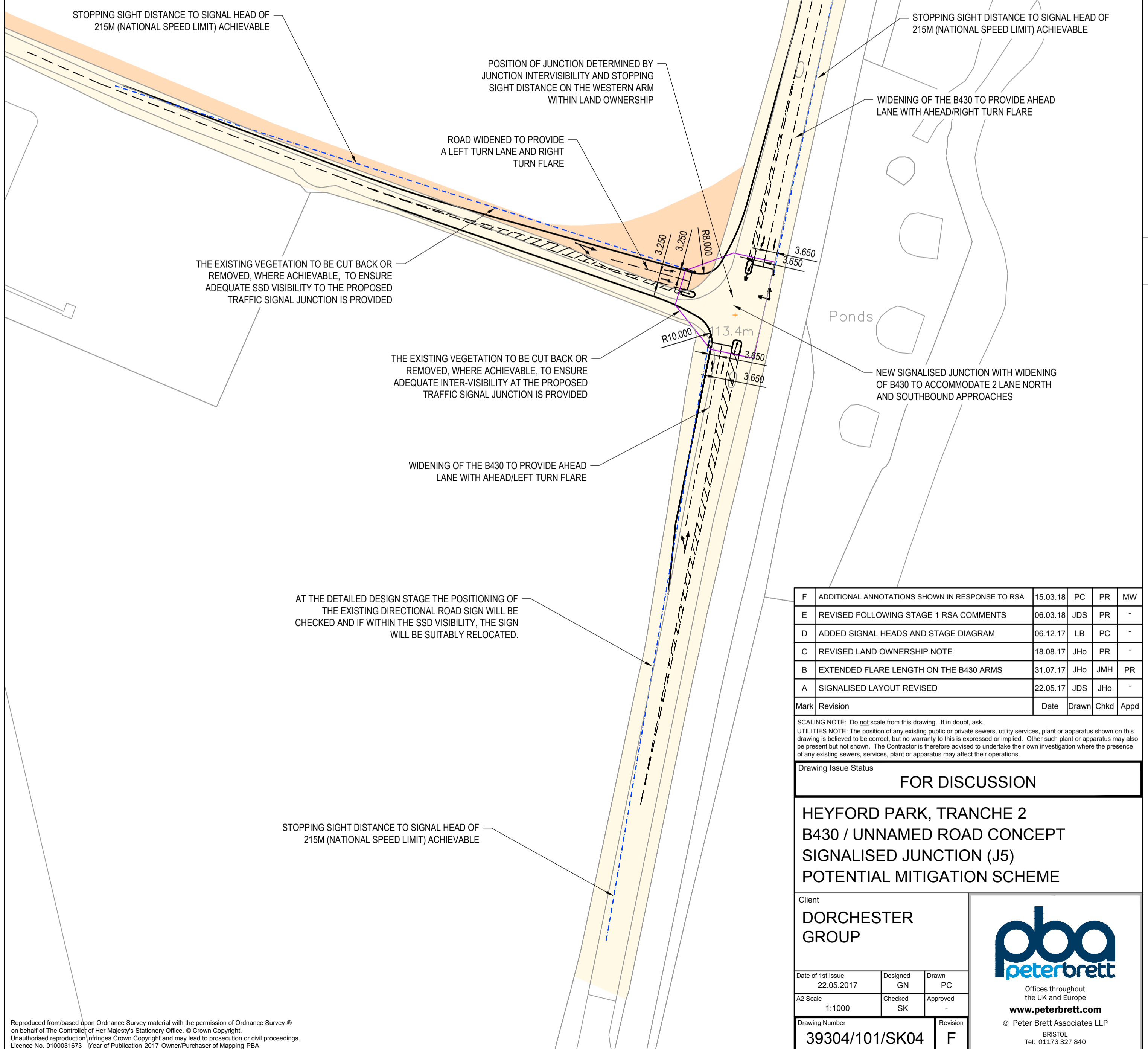
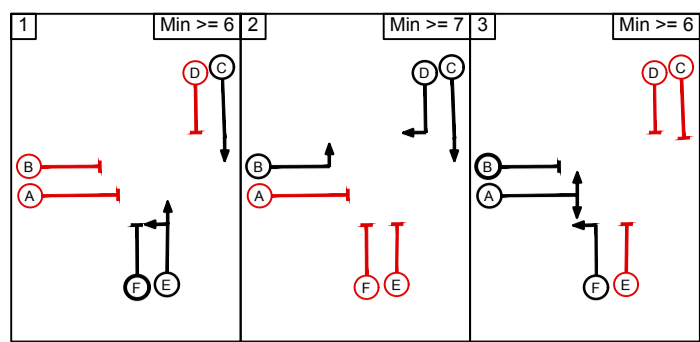

Mark	Revision	Date	Drawn	Chkd	Appd
F	ADDITIONAL ANNOTATIONS SHOWN IN RESPONSE TO RSA	15.03.18	PC	PR	MW
E	REVISED FOLLOWING STAGE 1 RSA COMMENTS	06.03.18	JDS	PR	-
D	ADDED SIGNAL HEADS AND STAGE DIAGRAM	06.12.17	LB	PC	-
C	REVISED LAND OWNERSHIP NOTE	18.08.17	JHo	PR	-
B	EXTENDED FLARE LENGTH ON THE B430 ARMS	31.07.17	JHo	JMH	PR
A	SIGNALISED LAYOUT REVISED	22.05.17	JDS	JHo	-

SCALING NOTE: Do not scale from this drawing. If in doubt, ask.  
 UTILITIES NOTE: The position of any existing public or private sewers, utility services, plant or apparatus shown on this drawing is believed to be correct, but no warranty to this is expressed or implied. Other such plant or apparatus may also be present but not shown. The Contractor is therefore advised to undertake their own investigation where the presence of any existing sewers, services, plant or apparatus may affect their operations.

Drawing Issue Status  
**FOR DISCUSSION**

**HEYFORD PARK, TRANCHE 2  
 B430 / UNNAMED ROAD CONCEPT  
 SIGNALISED JUNCTION (J5)  
 POTENTIAL MITIGATION SCHEME**

Client  
**DORCHESTER GROUP**

Date of 1st Issue 22.05.2017	Designed GN	Drawn PC
A2 Scale 1:1000	Checked SK	Approved -
Drawing Number <b>39304/101/SK04</b>	Revision <b>F</b>	



Offices throughout the UK and Europe  
**www.peterbrett.com**  
 © Peter Brett Associates LLP  
 BRISTOL  
 Tel: 01173 327 840

Reproduced from/based upon Ordnance Survey material with the permission of Ordnance Survey © on behalf of The Controller of Her Majesty's Stationery Office. © Crown Copyright. Unauthorised reproduction infringes Crown Copyright and may lead to prosecution or civil proceedings. Licence No. 0100031673 Year of Publication 2017 Owner/Purchaser of Mapping PBA





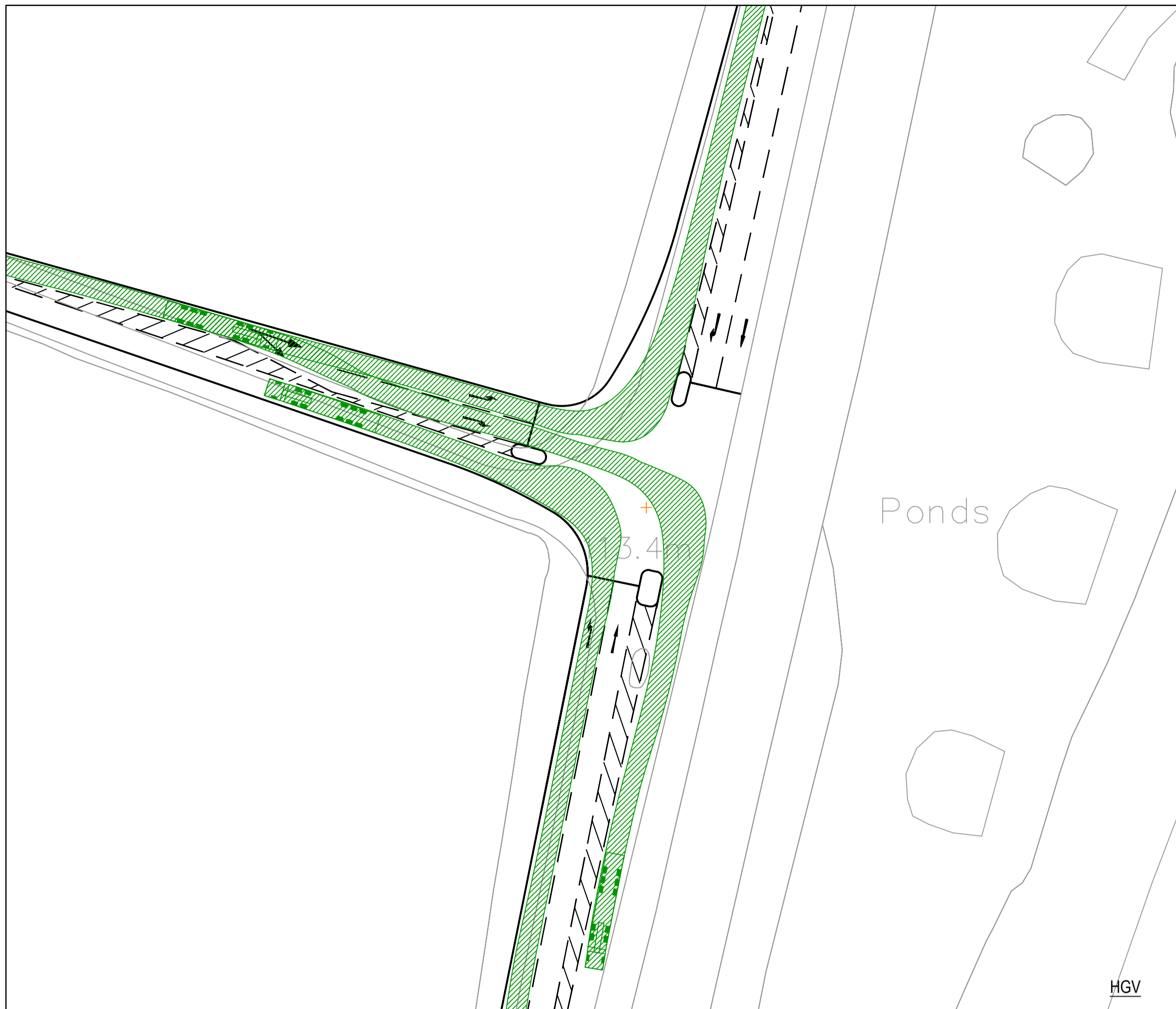

HGV

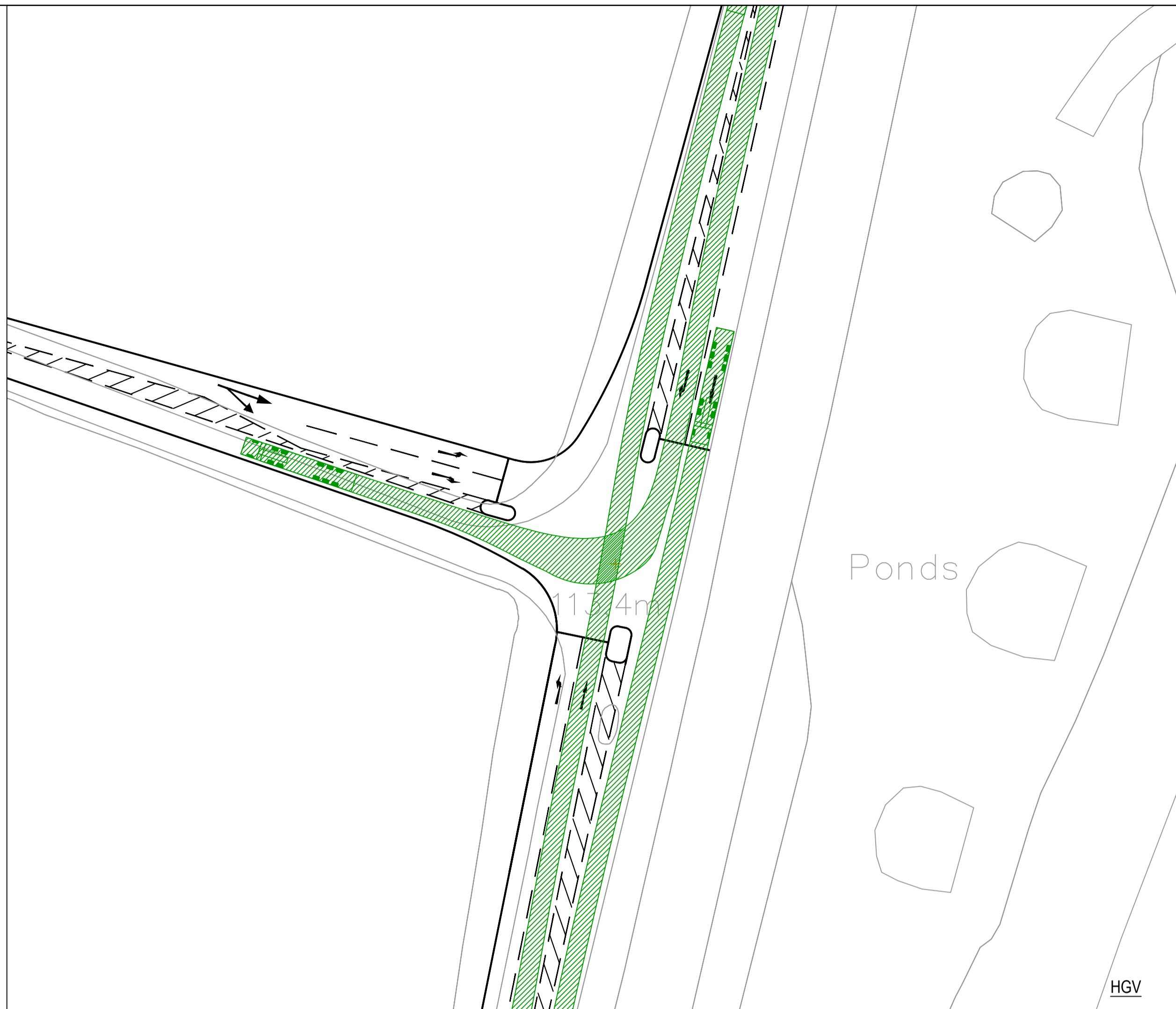

HGV

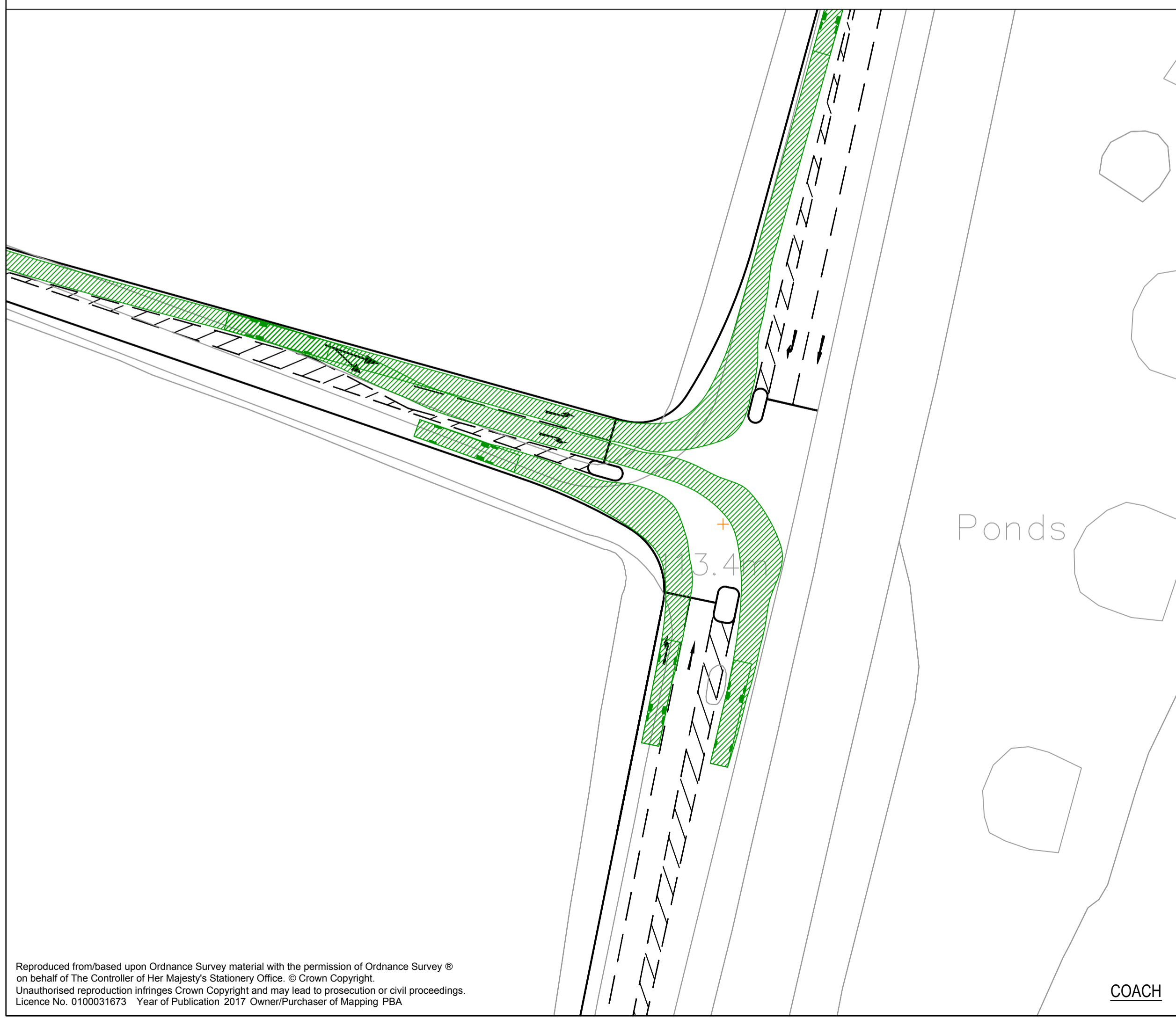

COACH

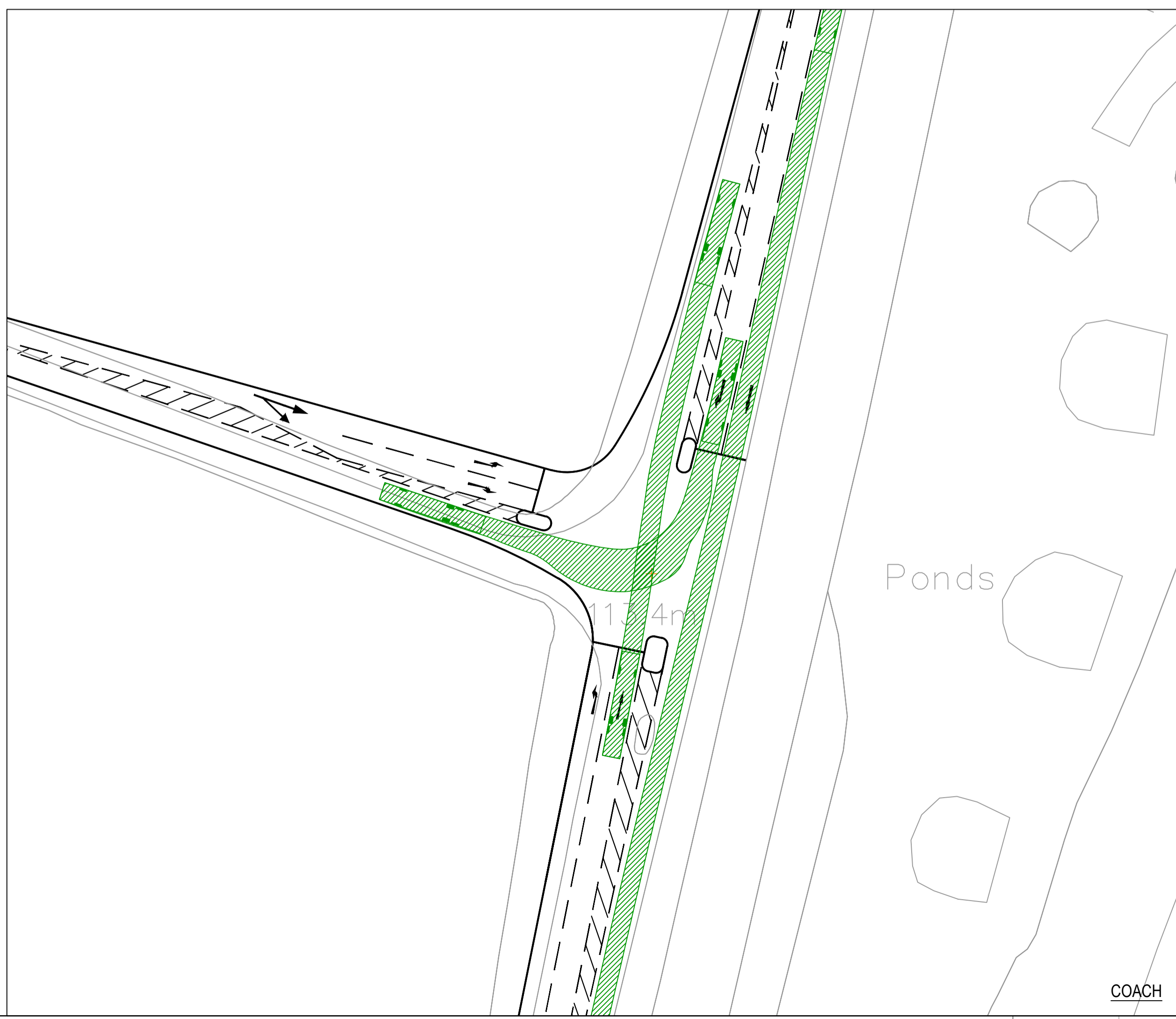

COACH

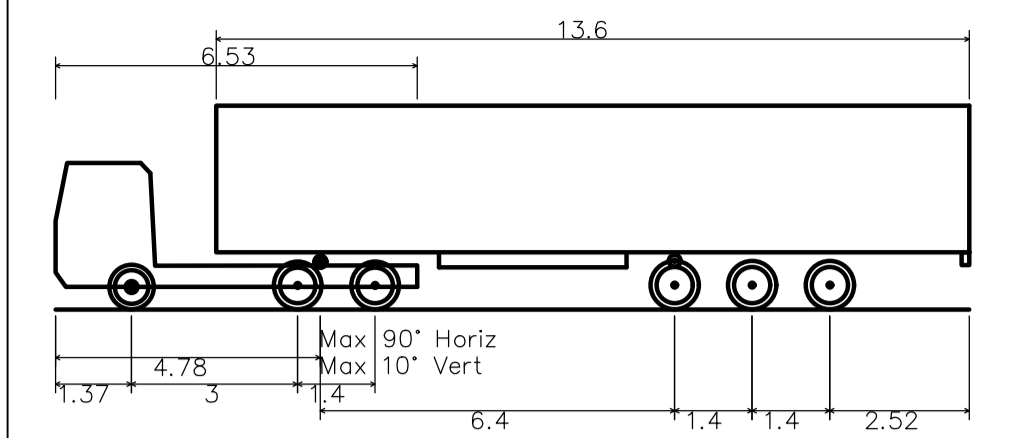

Max Legal Length (UK) Articulated Vehicle (16.5m)  
 Overall Length 16.500m  
 Overall Width 2.550m  
 Overall Body Height 3.681m  
 Min Body Ground Clearance 0.411m  
 Max Track Width 2.500m  
 Lock-to-lock time 6.00s  
 Curb to Curb Turning Radius 6.530m

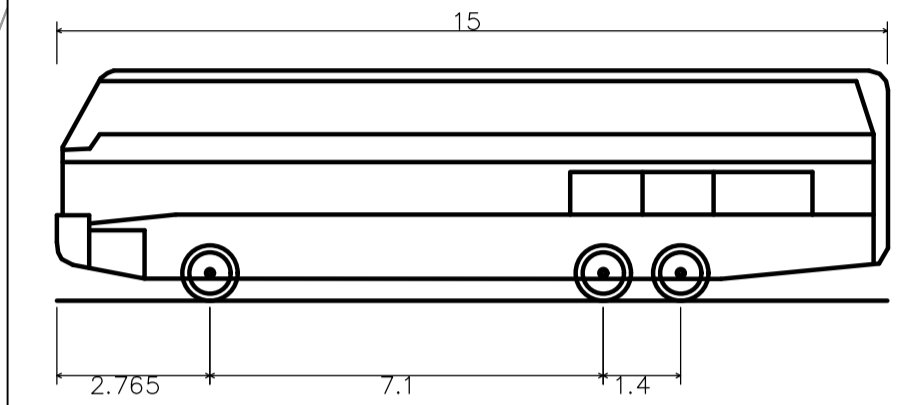

Plaxton Panther Bus  
 Overall Length 15.000m  
 Overall Width 2.500m  
 Overall Body Height 4.157m  
 Min Body Ground Clearance 0.397m  
 Track Width 2.500m  
 Lock-to-lock time 5.00s  
 Wall to Wall Turning Radius 12.500m

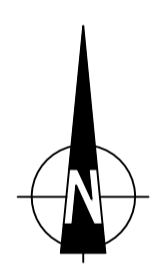

Mark	Revision	Date	Drawn	Chkd	Appd

SCALING NOTE: Do not scale from this drawing. If in doubt, ask.  
 UTILITIES NOTE: The position of any existing public or private sewers, utility services, plant or apparatus shown on this drawing is believed to be correct, but no warranty to this is expressed or implied. Other such plant or apparatus may also be present but not shown. The Contractor is therefore advised to undertake their own investigation where the presence of any existing sewers, services, plant or apparatus may affect their operations.

Drawing Issue Status  
**FOR DISCUSSION**

**HEYFORD PARK, TRANCHE 2  
 B430 / UNNAMED ROAD CONCEPT  
 SIGNALISED JUNCTION (J5)  
 SWEEP PATH ANALYSIS**

Client <b>DORCHESTER GROUP</b>			 Offices throughout the UK and Europe <b>www.peterbrett.com</b> © Peter Brett Associates LLP BRISTOL Tel: 01173 327 840
Date of 1st Issue 18.08.2017	Designed JHo	Drawn JHo	
A1 Scale 1:500	Checked PR	Approved -	
Drawing Number <b>39304/5501/SK17</b>	Revision -		

Reproduced from/based upon Ordnance Survey material with the permission of Ordnance Survey © on behalf of The Controller of Her Majesty's Stationery Office. © Crown Copyright. Unauthorised reproduction infringes Crown Copyright and may lead to prosecution or civil proceedings. Licence No. 0100031673 Year of Publication: 2017 Owner/Purchaser of Mapping: PBA



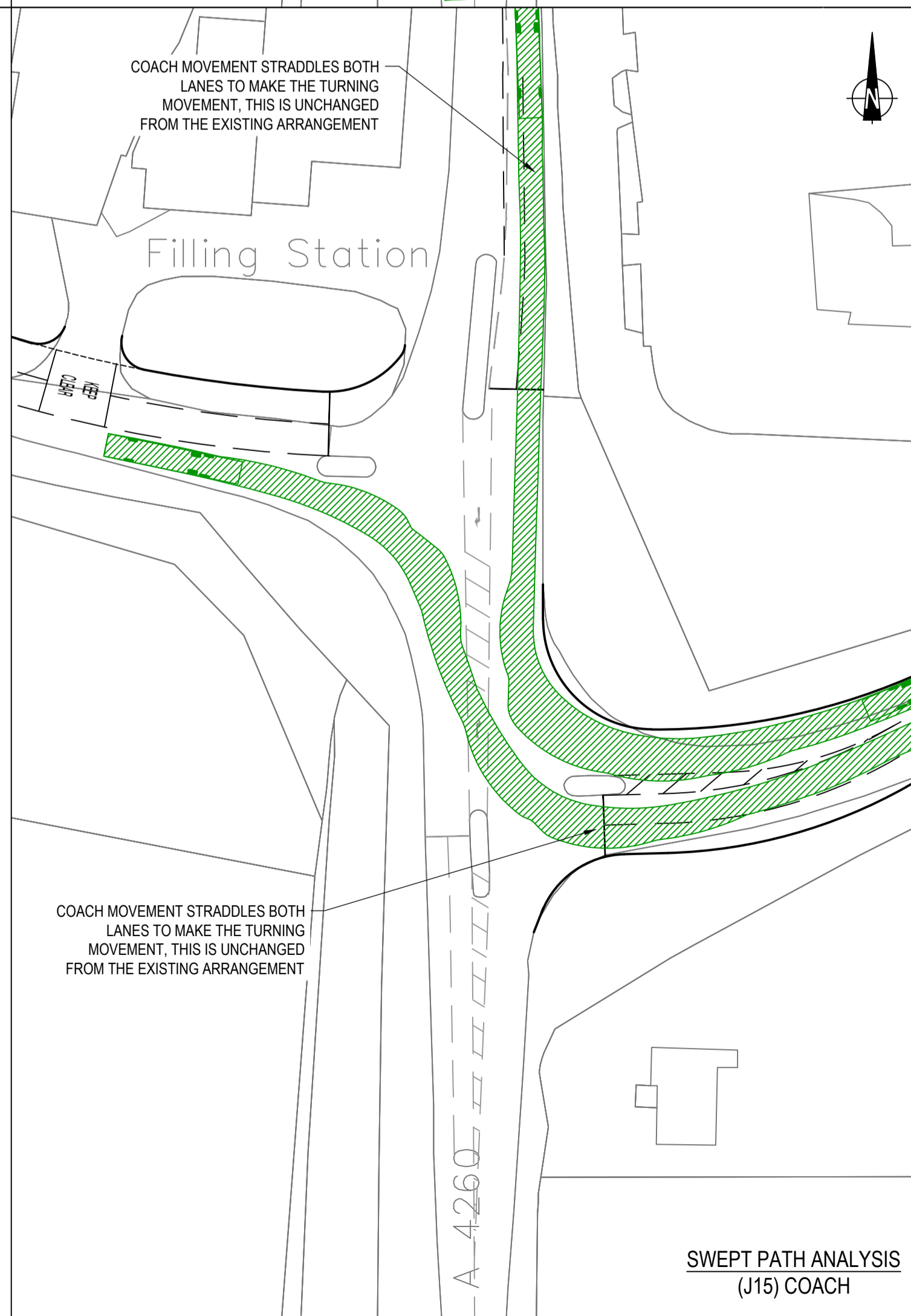
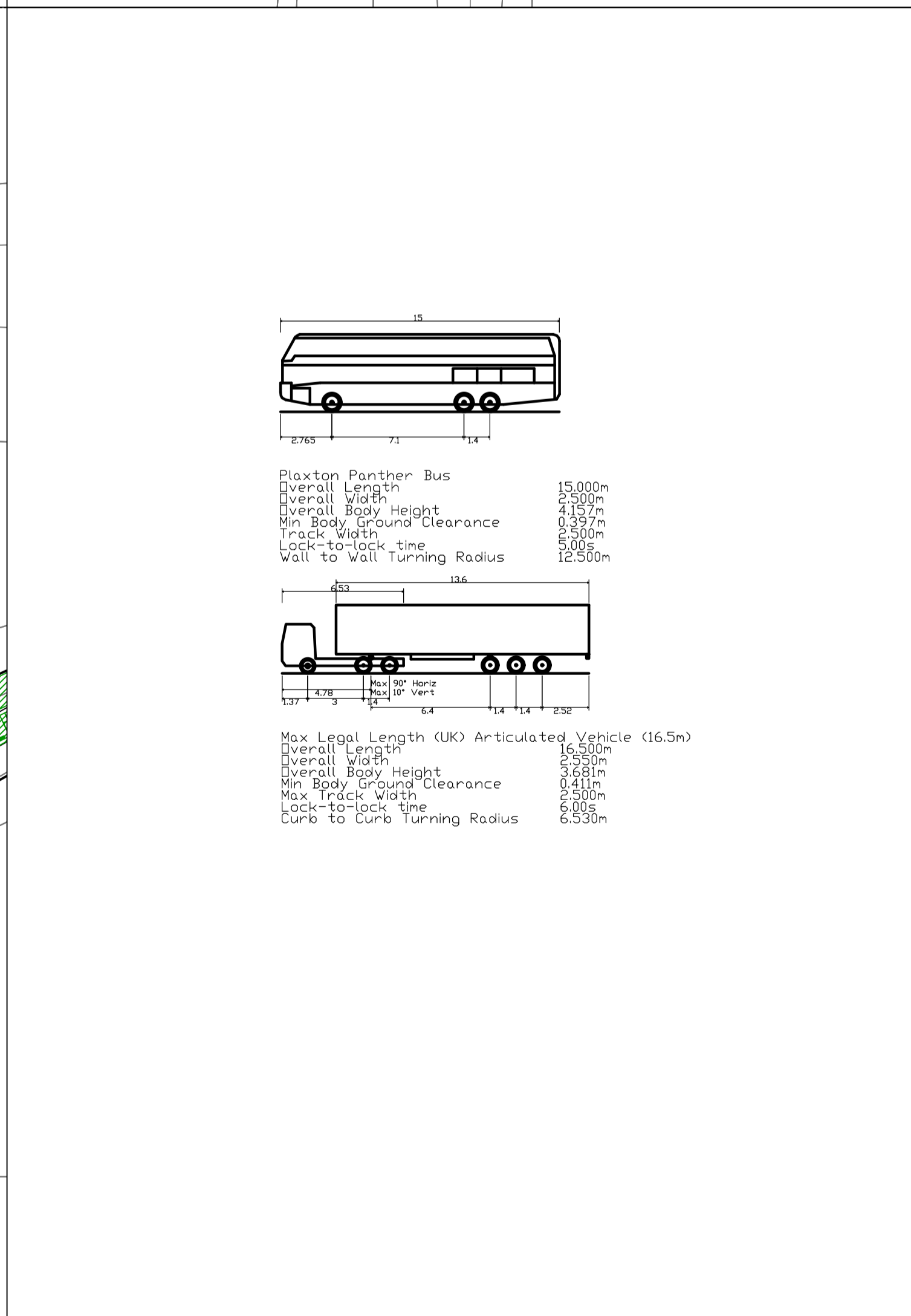
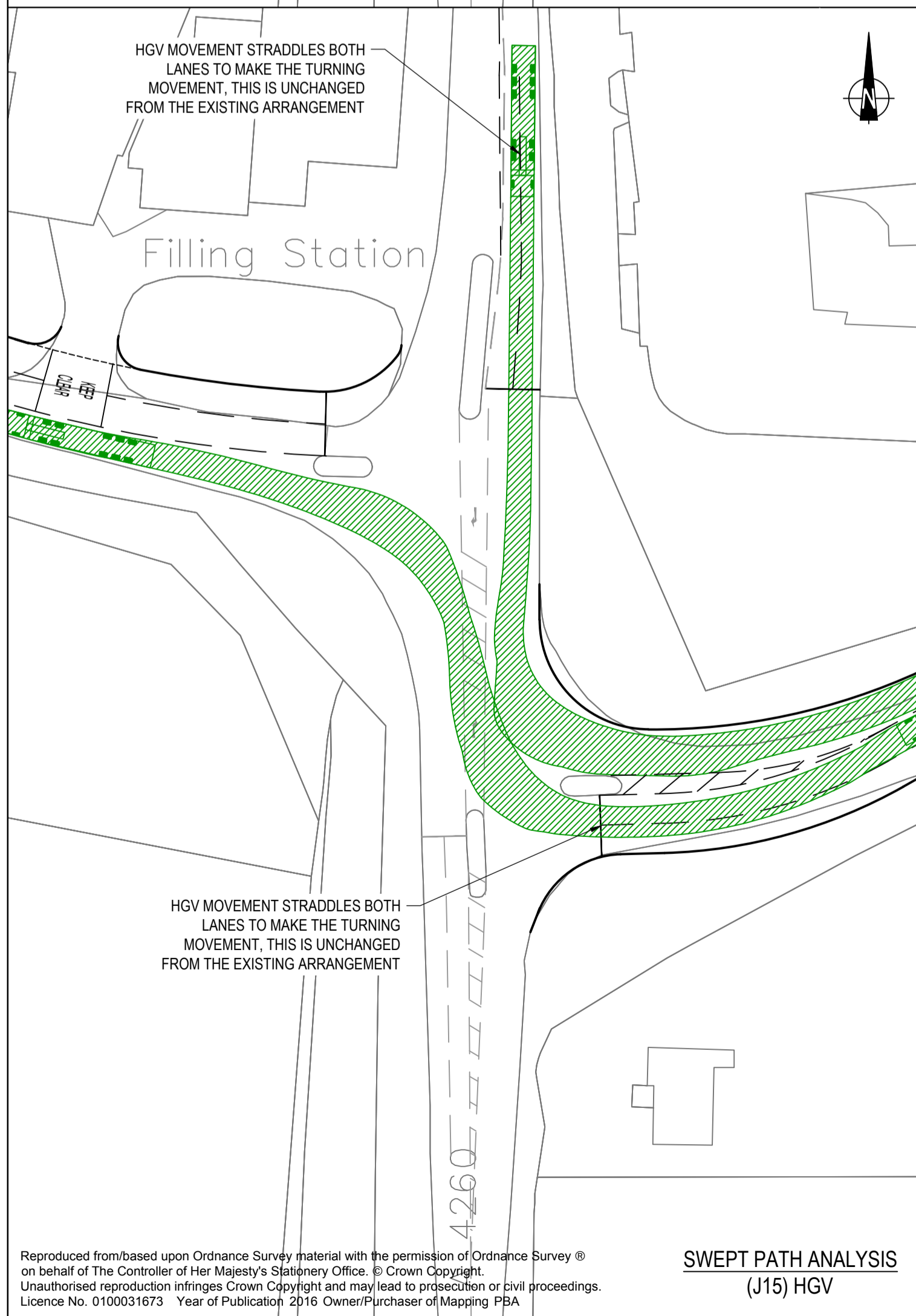
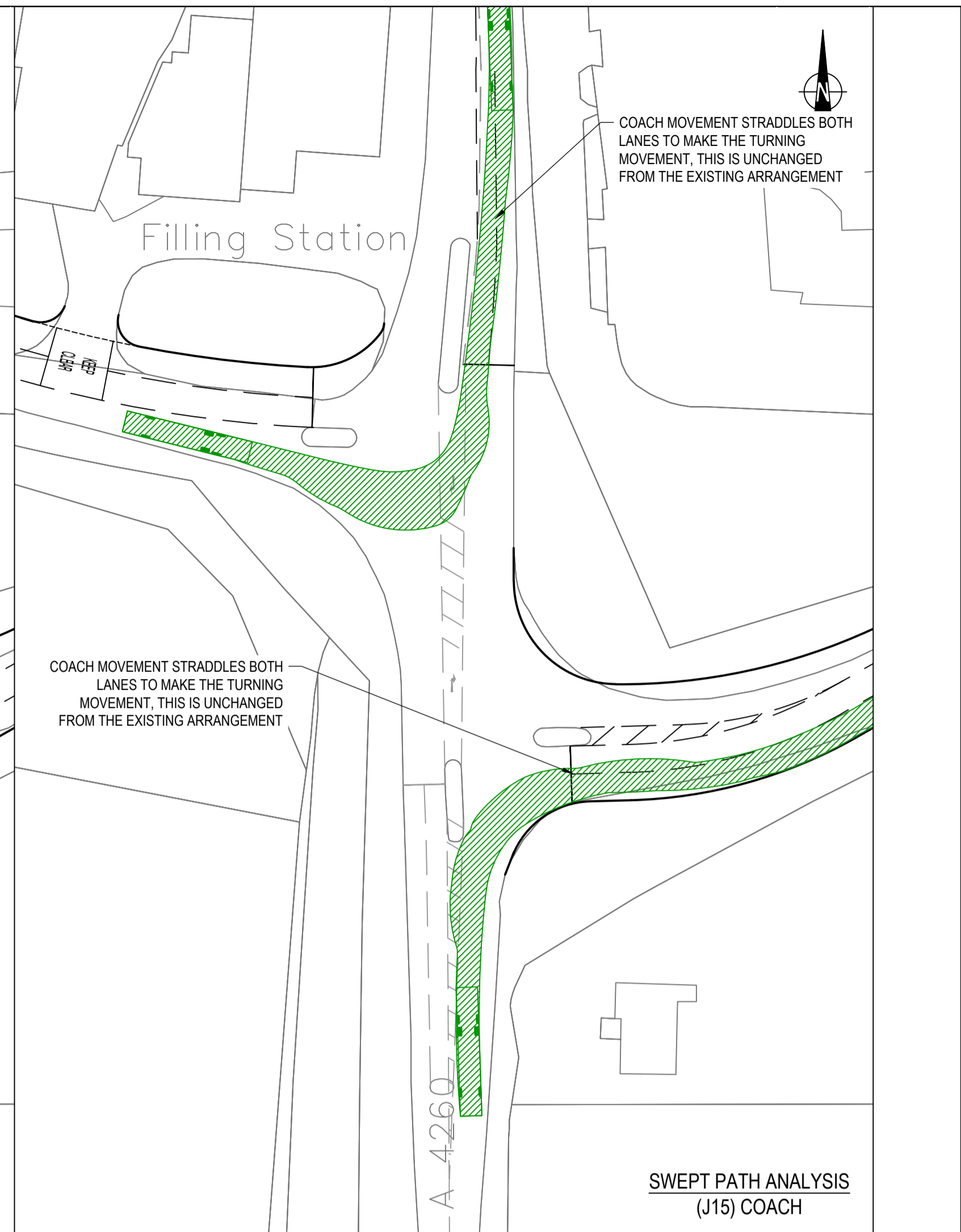
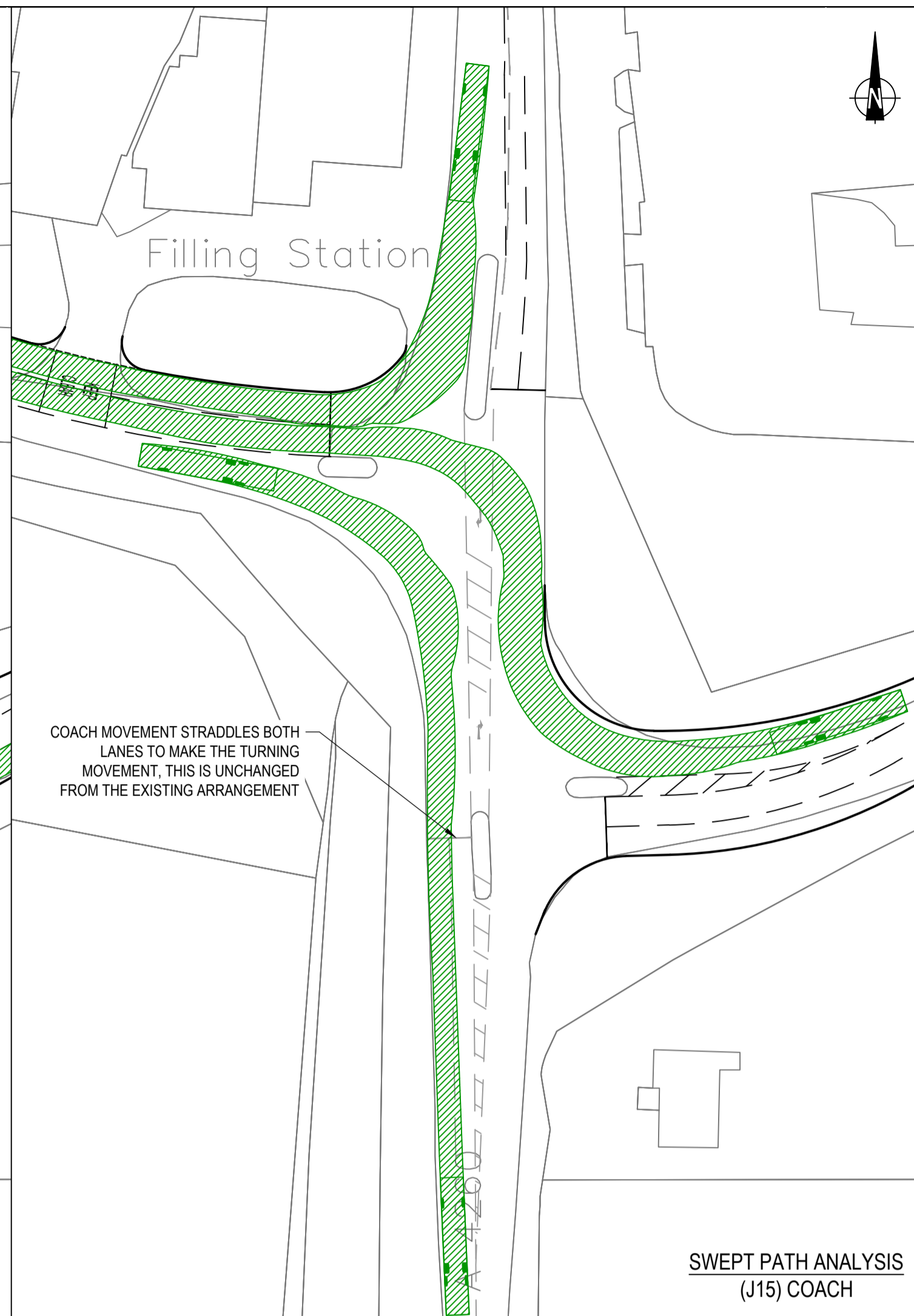
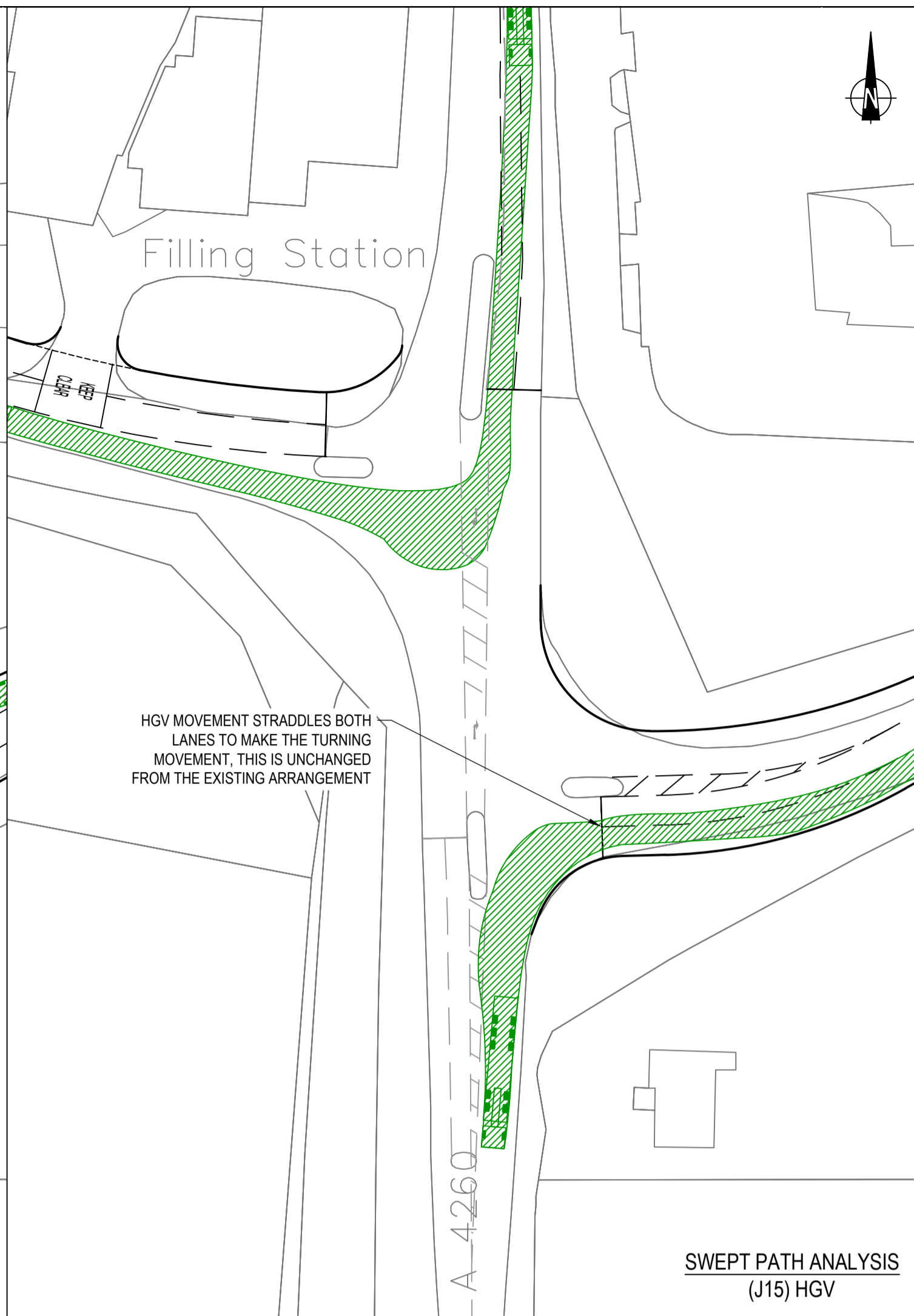
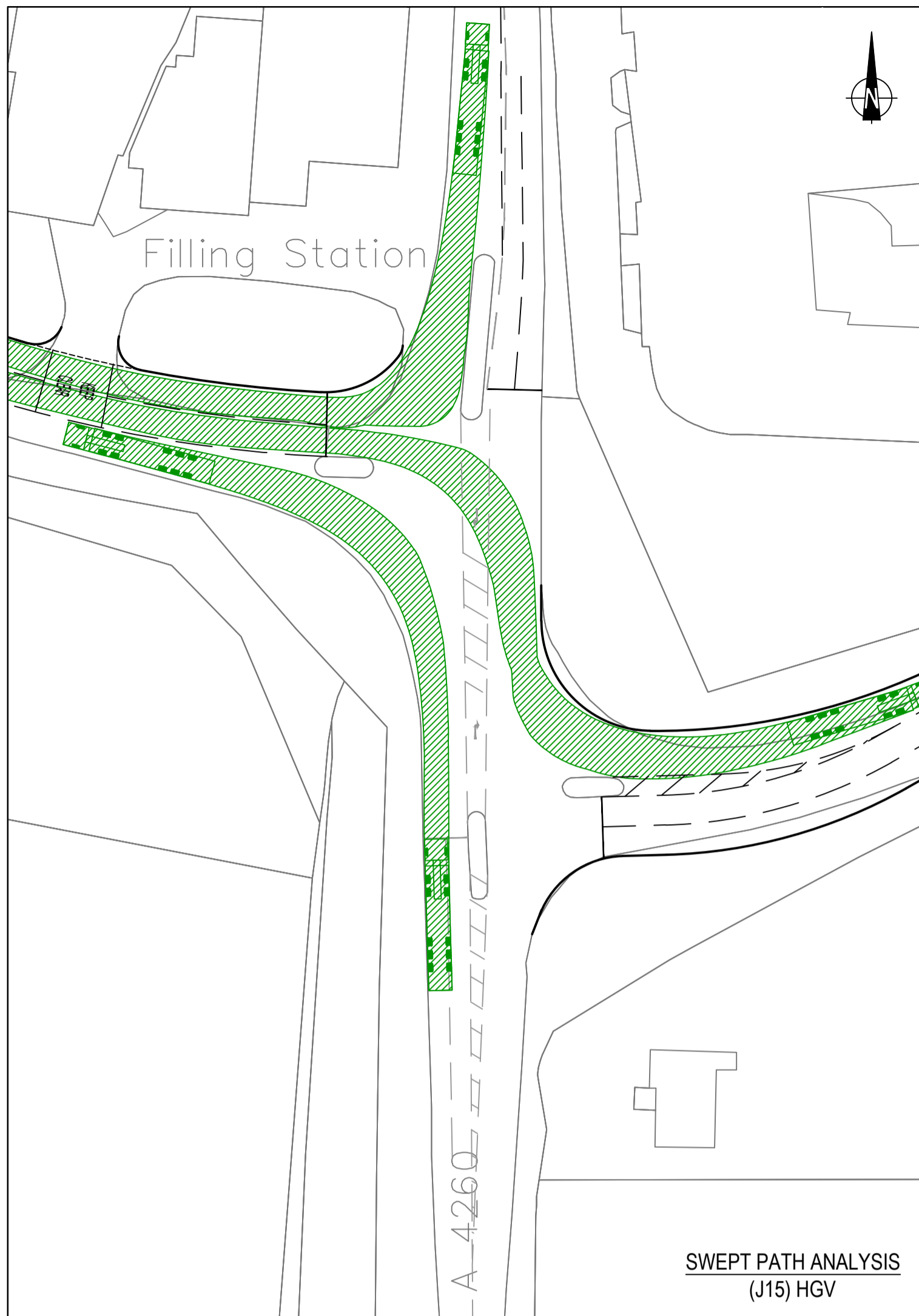

Mark	Revision	Date	Drawn	Chkd	Appd
A	REVISION TO FILLING STATION ACCESS TIE IN	15.11.17	LB	PC	-

SCALING NOTE: Do not scale from this drawing. If in doubt, ask.  
 UTILITIES NOTE: The position of any existing public or private sewers, utility services, plant or apparatus shown on this drawing is believed to be correct, but no warranty to this is expressed or implied. Other such plant or apparatus may also be present but not shown. The Contractor is therefore advised to undertake his own investigation where the presence of any existing sewers, services, plant or apparatus may affect his operations.

Drawing Issue Status  
**FOR DISCUSSION**

**HEYFORD PARK, TRANCHE 2  
 HOPCROFTS HOLT JUNCTION (J15)  
 POTENTIAL MITIGATION SCHEMES  
 SWEPT PATH ANALYSIS**

Client <b>DORCHESTER GROUP</b>			 Offices throughout the UK and Europe <b>www.peterbrett.com</b> © Peter Brett Associates LLP BRISTOL Tel: 0117 928 1560
Date of 1st Issue 18.08.2017	Designed JHo	Drawn JHo	
A1 Scale 1:500	Checked PR	Approved -	
Drawing Number <b>39304/5501/SK18</b>	Revision <b>A</b>		

Reproduced from/based upon Ordnance Survey material with the permission of Ordnance Survey © on behalf of The Controller of Her Majesty's Stationery Office. © Crown Copyright. Unauthorised reproduction infringes Crown Copyright and may lead to prosecution or civil proceedings. Licence No. 0100031673 Year of Publication: 2016 Owner/Purchaser of Mapping: PBA



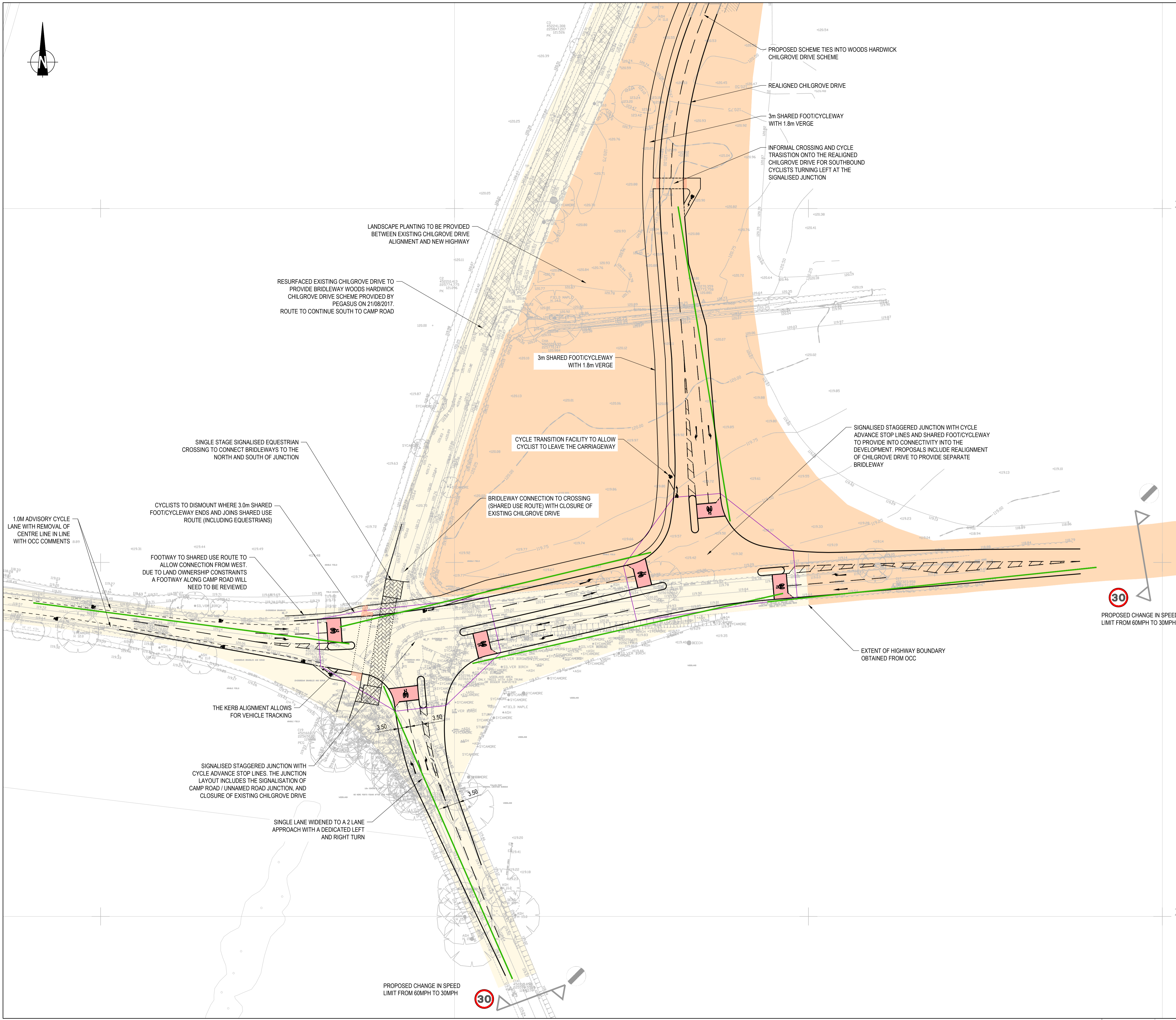
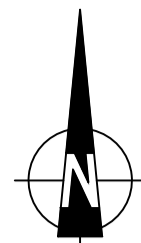

- NOTES:
1. THE LAYOUT IS SUBJECT TO DETAILED DESIGN, ROAD SAFETY AUDIT, CAPACITY TESTING, GROUND INVESTIGATIONS RESULTS & EARTHWORKS MODELLING, UTILITIES & SERVICES AND CONFIRMATION OF LAND OWNERSHIP;
  2. THE DETAILED DESIGN LAYOUT WILL BE DESIGNED IN ACCORDANCE WITH ALL RELEVANT DESIGN GUIDANCE AND STANDARDS;
  3. THE LAYOUT HAS BEEN BASED ON THE APPROPRIATE DESIGN SPEED FOR OUR CURRENT PROPOSALS;
  4. THIS DRAWING SHOULD BE READ IN CONJUNCTION WITH ALL RELEVANT ASSOCIATED DOCUMENTS, AND
  5. THE USE OF THE DRAWING DOES NOT ABSOLVE THE CLIENT FROM THEIR RESPONSIBILITIES IN REGARDS TO HEALTH & SAFETY AND CDM REGULATIONS;

- KEY:
- HIGHWAY BOUNDARY INFORMATION RECEIVED FROM OXFORD COUNTY COUNCIL ON 13.03.17 AND INTERPRETED BY PBA
  - LAND UNDER THE CLIENT'S CONTROL. LAND TITLE ON288089 (UPPER HEYFORD GP LTD)
  - EQUESTRIAN CROSSING
  - 90M STOPPING SIGHT DISTANCE TO A PRIMARY SIGNAL HEAD IN ACCORDANCE WITH DMRB FOR A 30MPH ROAD
  - JUNCTION INTERVISIBILITY

C	REVISED PEDESTRIAN CYCLE ROUTE ALONG CHILGROVE DRIVE	08.02.18	JHo	PC	PR
B	ADDED NOTE ON PLANTING	17.01.18	AA	PR	-
A	AMENDMENTS MADE IN ACCORDANCE WITH OCC COMMENTS	04.01.18	PC	PR	-
Mark	Revision	Date	Drawn	Chkd	Appd

SCALING NOTE: Do not scale from this drawing. If in doubt, ask.  
 UTILITIES NOTE: The position of any existing public or private sewers, utility services, plant or apparatus shown on this drawing is believed to be correct, but no warranty to this is expressed or implied. Other such plant or apparatus may also be present but not shown. The Contractor is therefore advised to undertake their own investigation where the presence of any existing sewers, services, plant or apparatus may affect their operations.

Drawing Issue Status  
**FOR DISCUSSION**

**HEYFORD PARK, TRANCHE 2  
 CHILGROVE DRIVE  
 POTENTIAL SIGNALISED JUNCTION**

Client <b>DORCHESTER GROUP</b>			
Date of 1st Issue 06.10.2017	Designed JHo	Drawn JHo	
A1 Scale 1:500	Checked PC	Approved PR	Offices throughout the UK and Europe <b>www.peterbrett.com</b> © Peter Brett Associates LLP BRISTOL Tel: 01173 327 840
Drawing Number <b>39304/5501/SK26</b>	Revision <b>C</b>		



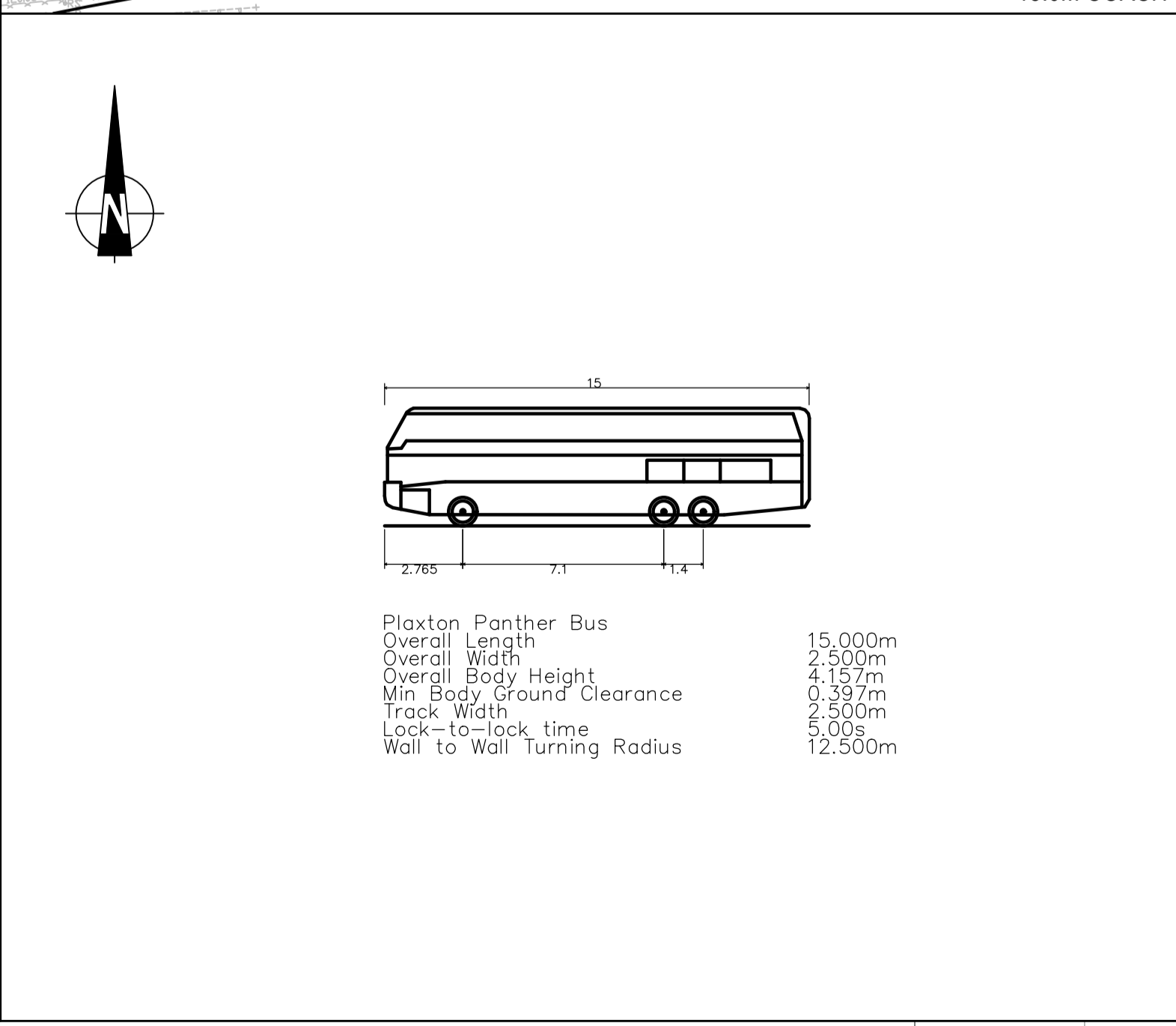
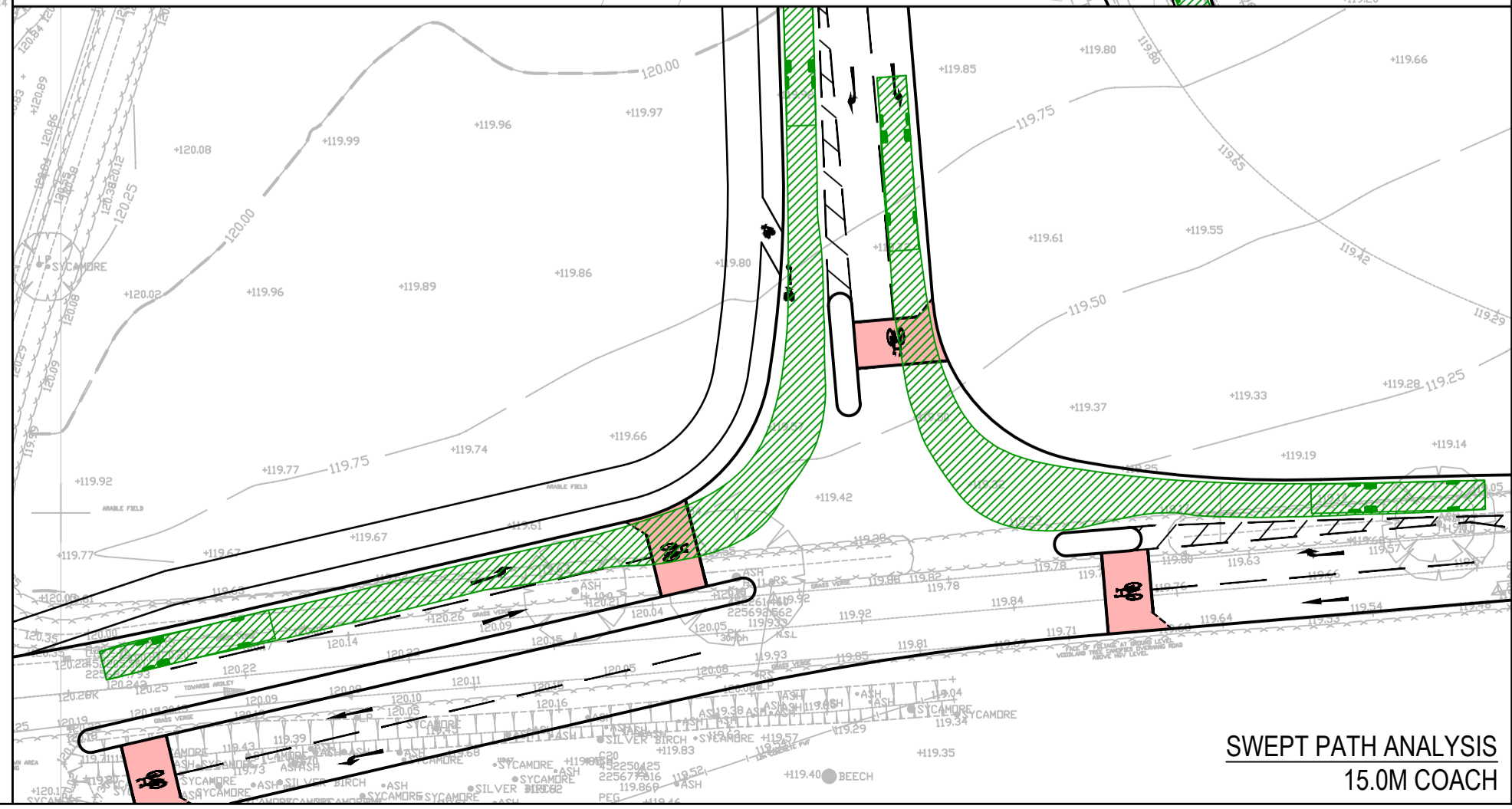
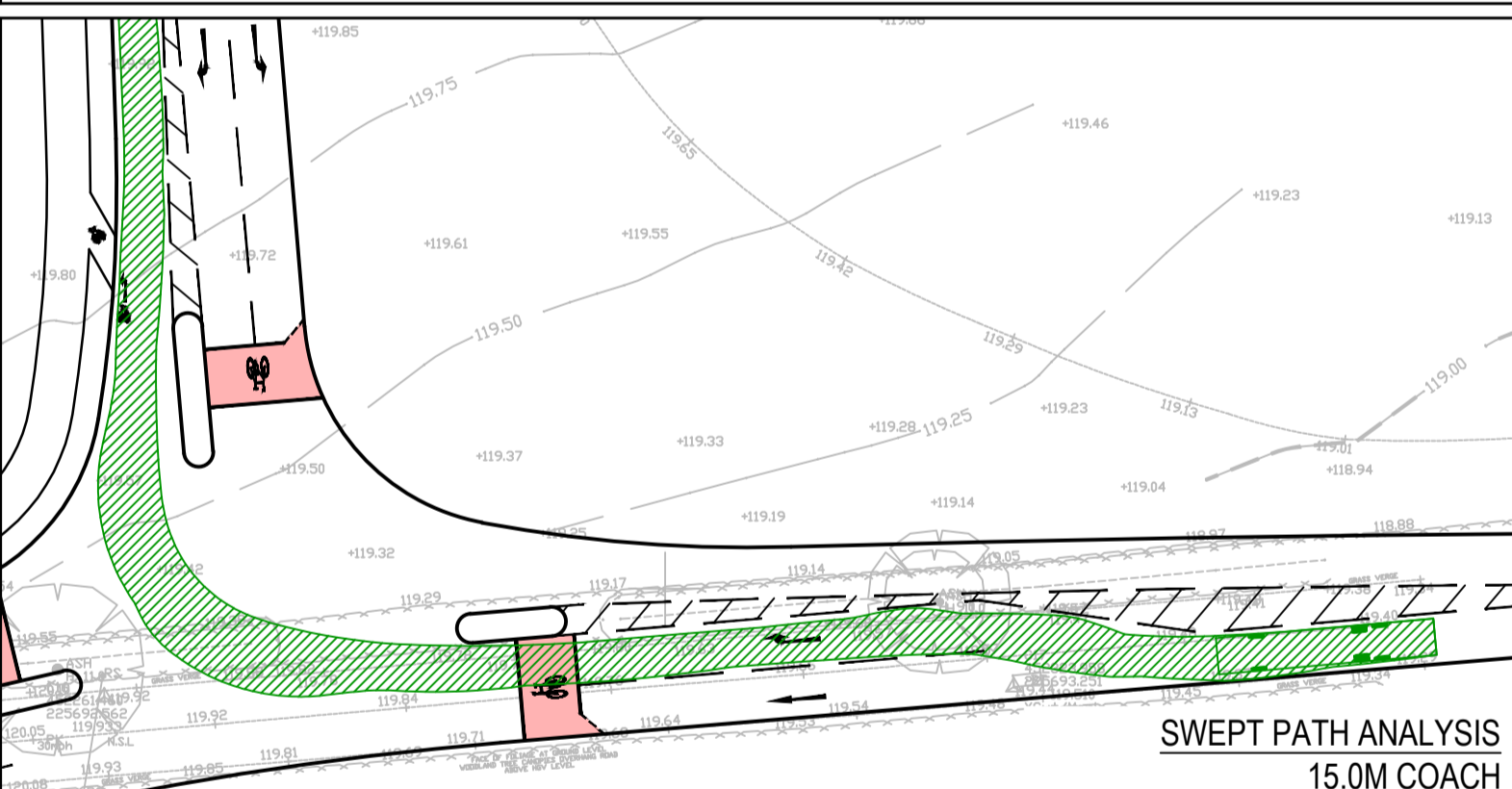
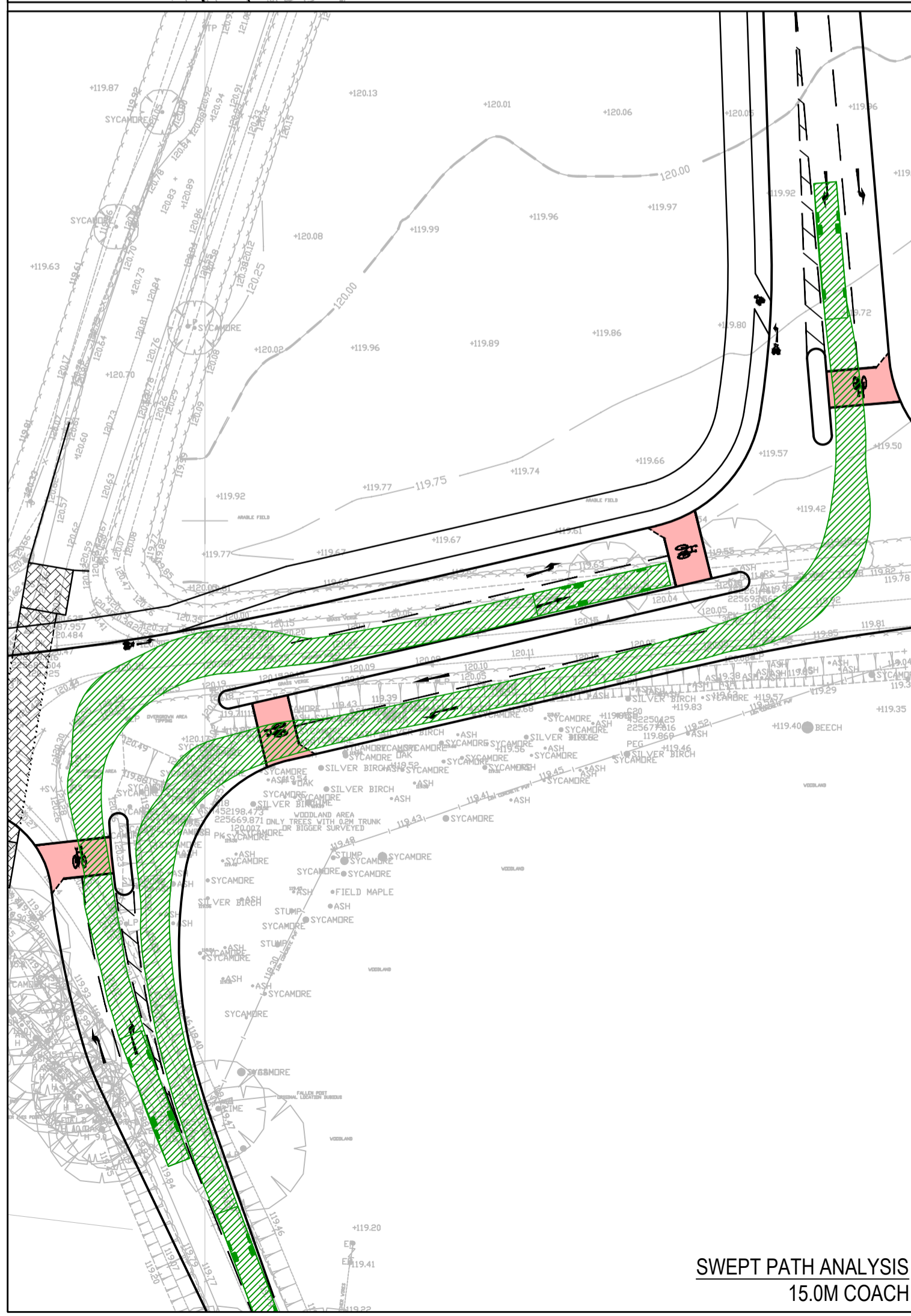
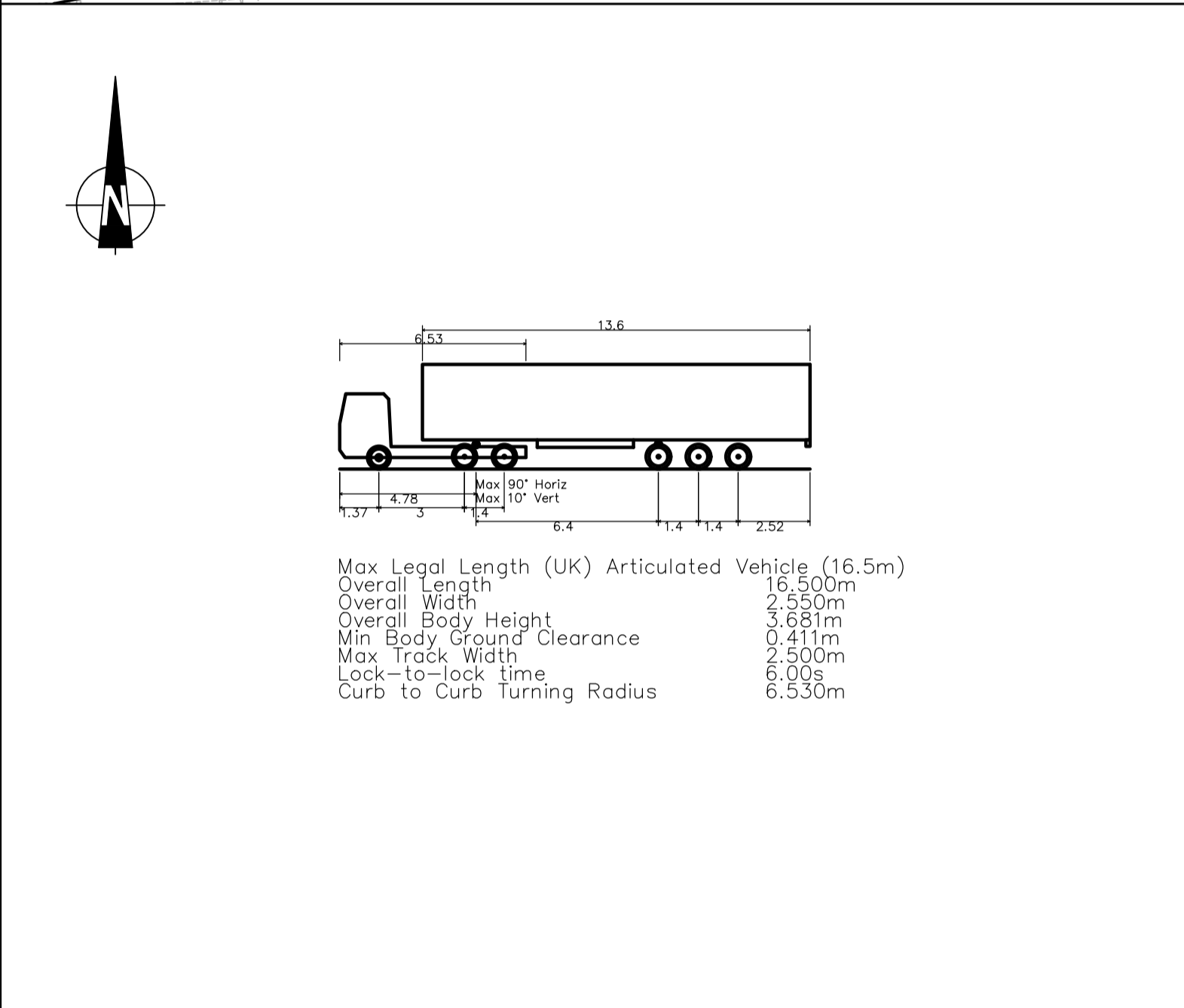
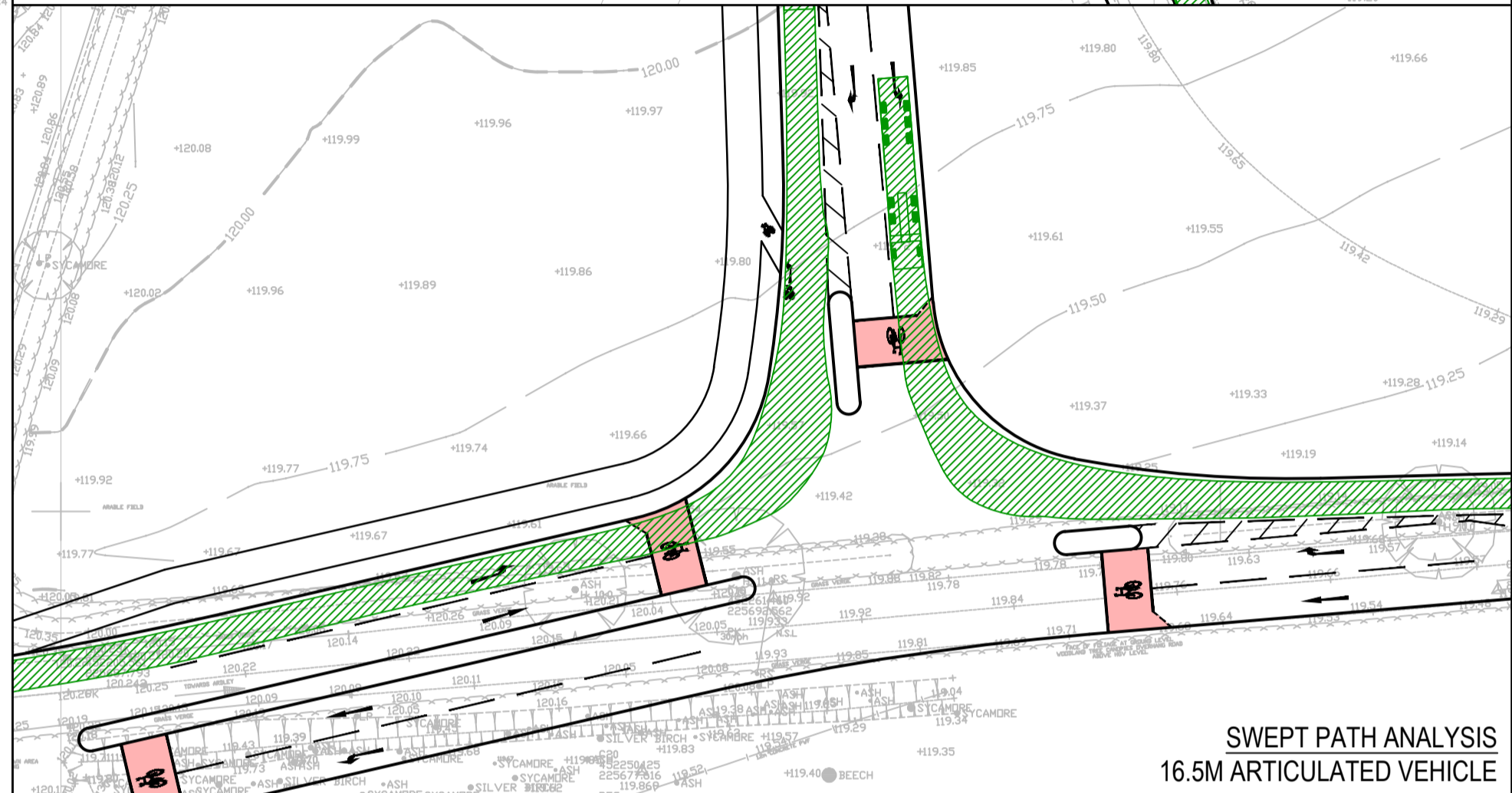
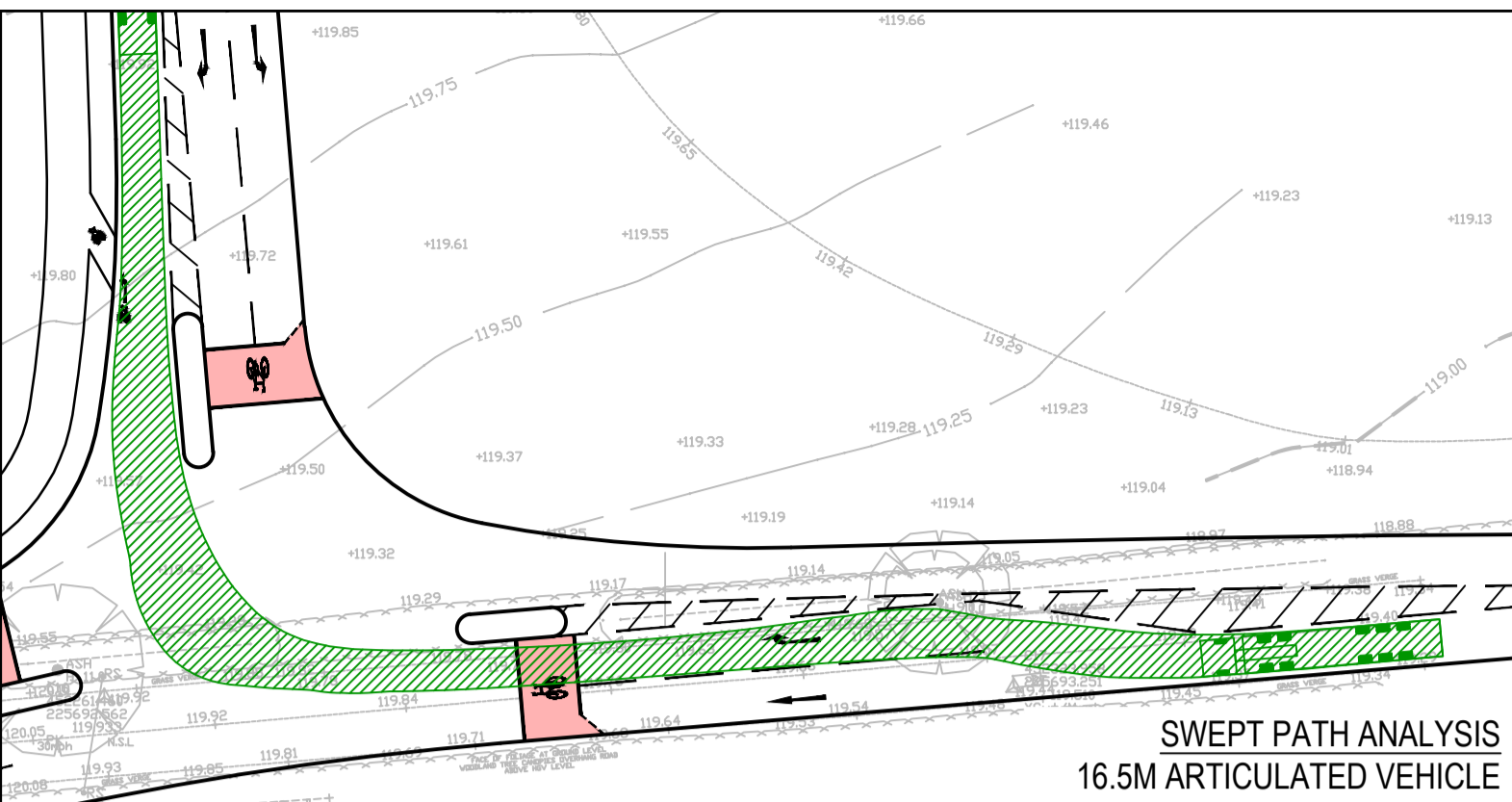
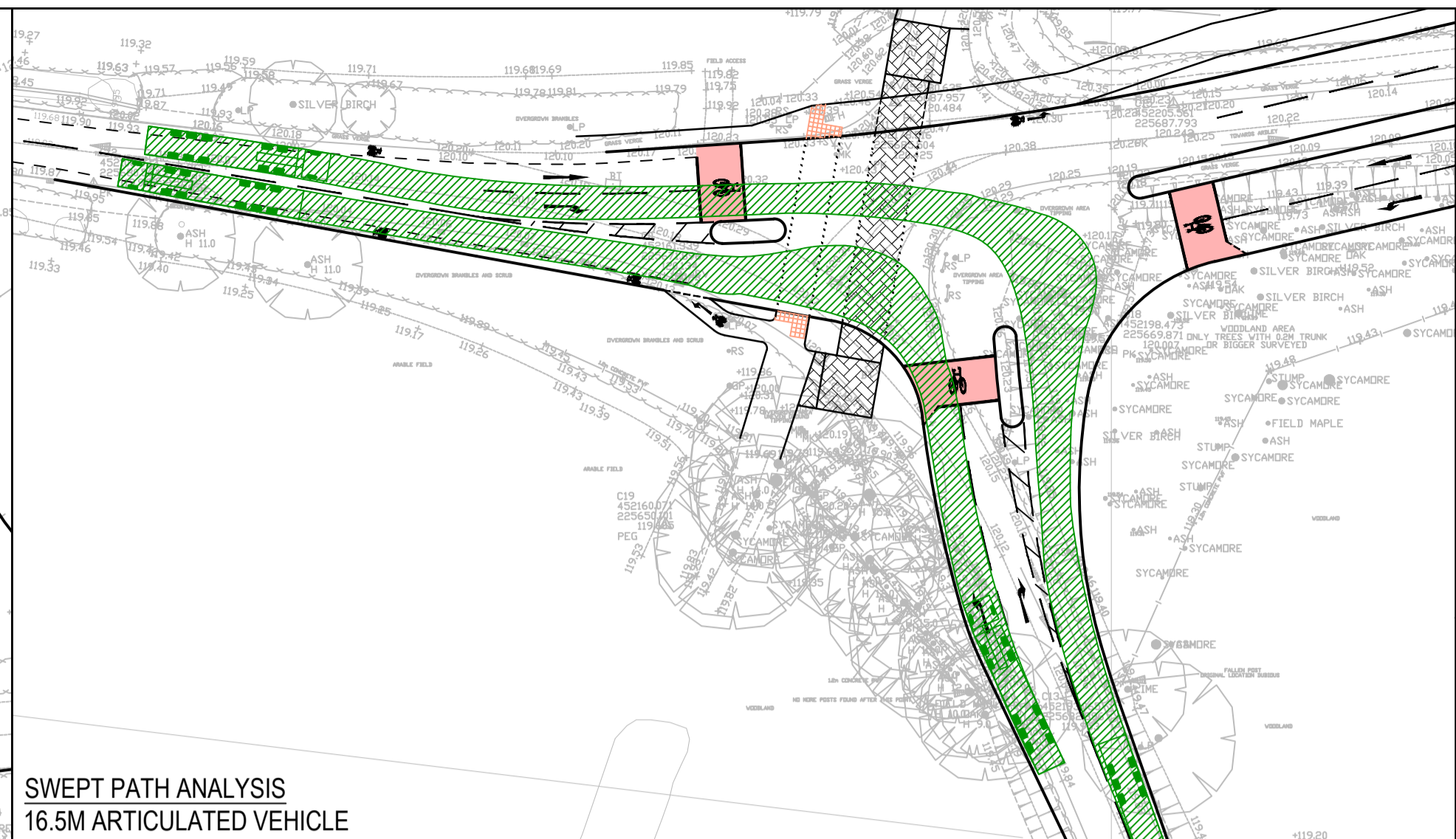
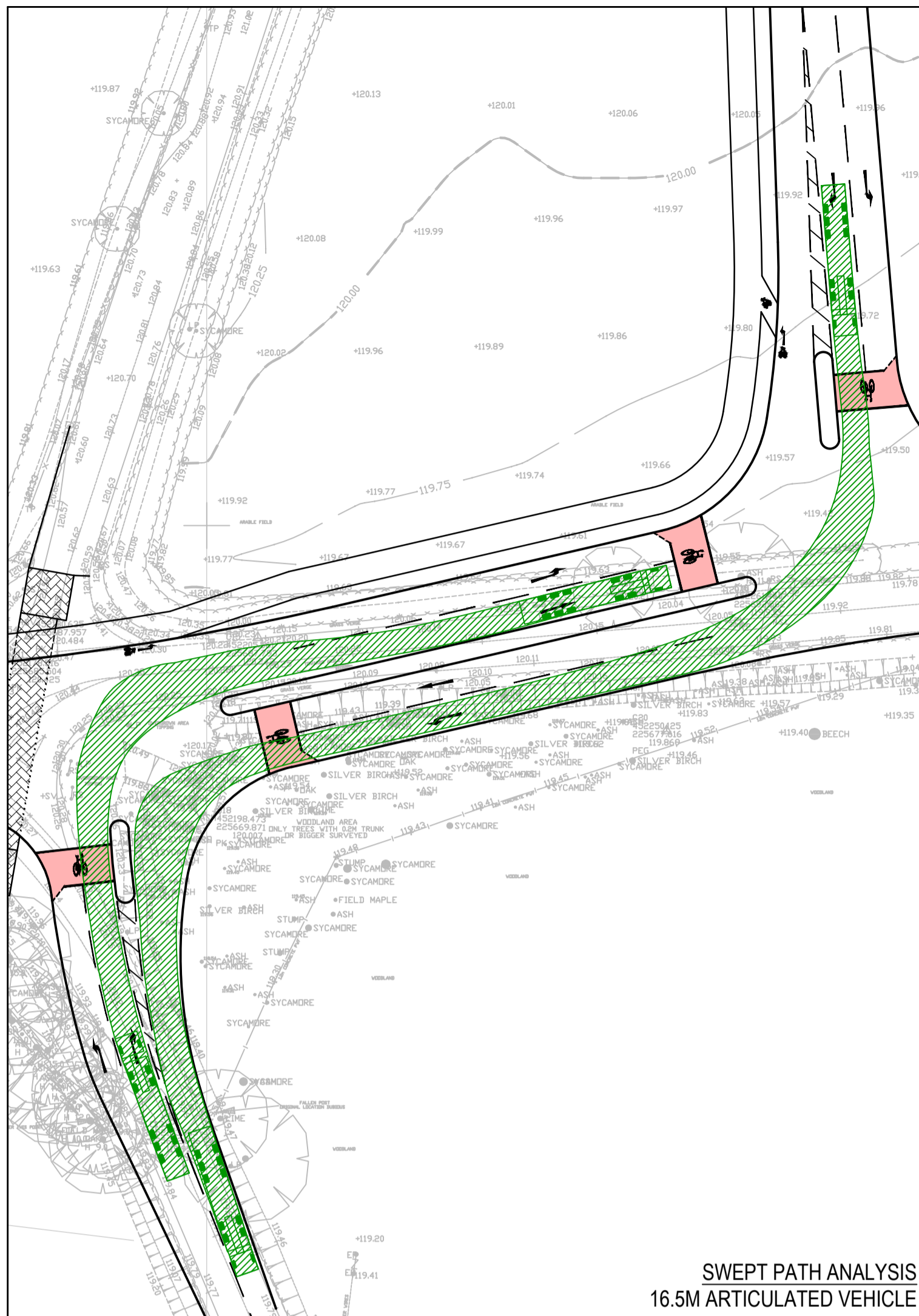

Mark	Revision	Date	Drawn	Chkd	Appd
A	LATEST LAYOUT SHOWN AND SPA AMENDED AS REQUIRED	20.03.18	PC	PR	MW

SCALING NOTE: Do not scale from this drawing. If in doubt, ask.  
 UTILITIES NOTE: The position of any existing public or private sewers, utility services, plant or apparatus shown on this drawing is believed to be correct, but no warranty to this is expressed or implied. Other such plant or apparatus may also be present but not shown. The Contractor is therefore advised to undertake their own investigation where the presence of any existing sewers, services, plant or apparatus may affect their operations.

Drawing Issue Status  
**FOR DISCUSSION**

HEYFORD PARK, TRANCHE 2  
 CHILGROVE DRIVE  
 POTENTIAL SIGNALISED JUNCTION  
 SWEPT PATH ANALYSIS

Client <b>DORCHESTER GROUP</b>			 Offices throughout the UK and Europe <b>www.peterbrett.com</b> © Peter Brett Associates LLP BRISTOL Tel: 01173 327 840
Date of 1st Issue 16.11.2017	Designed LB	Drawn LB	
A1 Scale 1:500	Checked PC	Approved PC	
Drawing Number 39304/5501/SK42	Revision A		





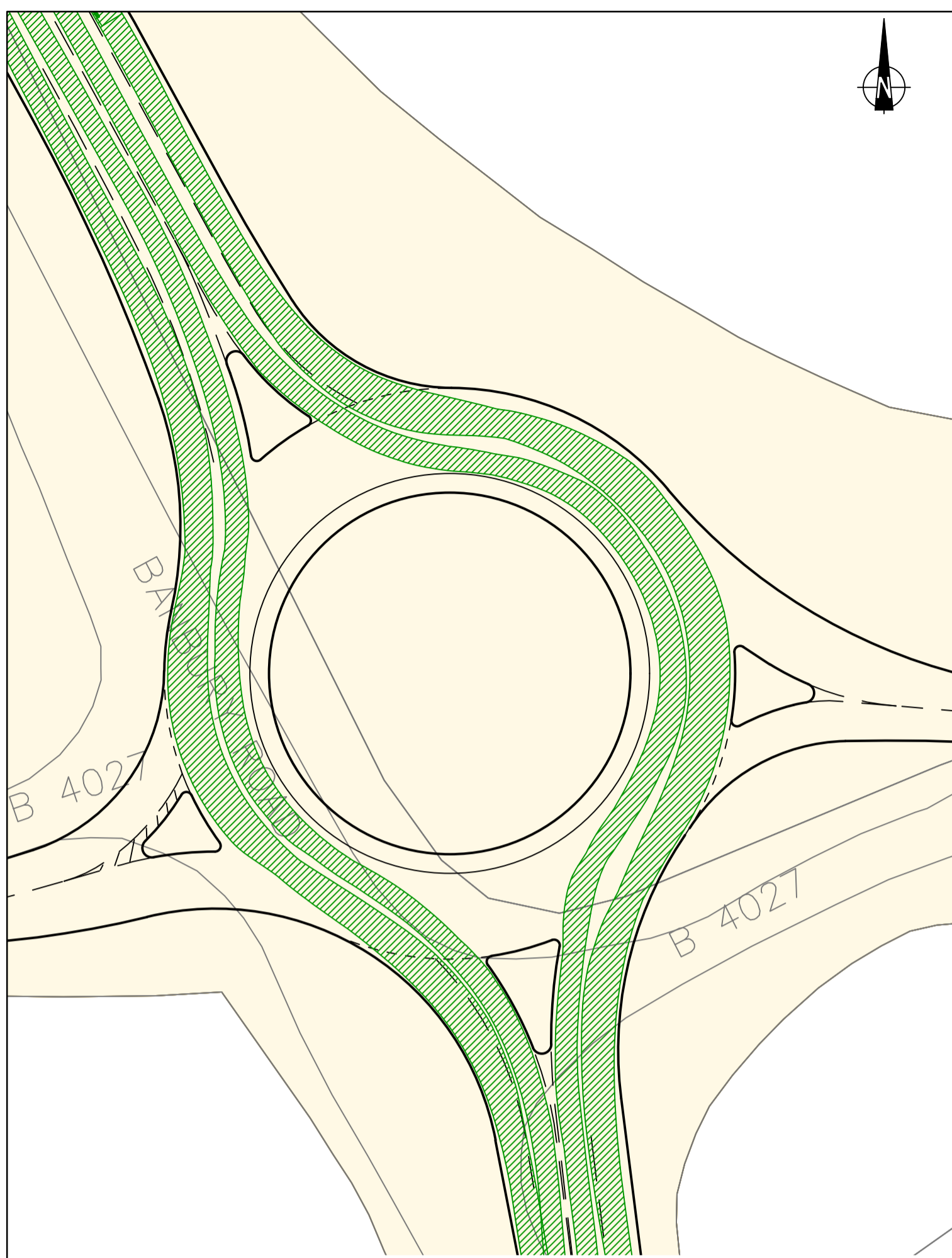

SWEPT PATH ANALYSIS  
16.5M ARTICULATED VEHICLE - NEARSIDE AHEAD MANOEUVRE  
7.5T BOX VAN - OFFSIDE AHEAD MANOEUVRE

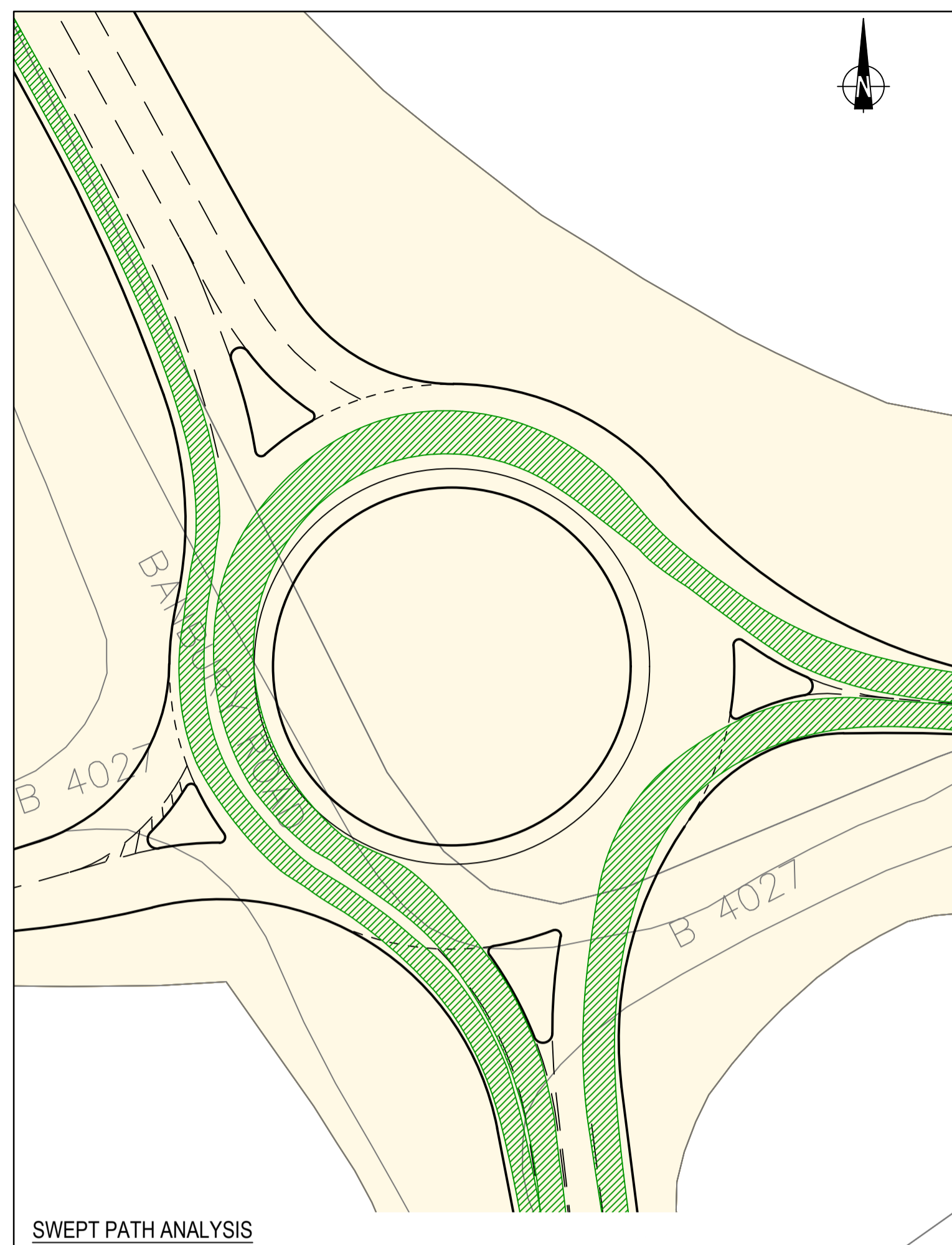

SWEPT PATH ANALYSIS  
16.5M ARTICULATED VEHICLE - OFFSIDE SOUTH TO EAST MANOEUVRE & EAST TO SOUTH MANOEUVRE  
7.5T BOX VAN - NEARSIDE SOUTH TO NORTH MANOEUVRE

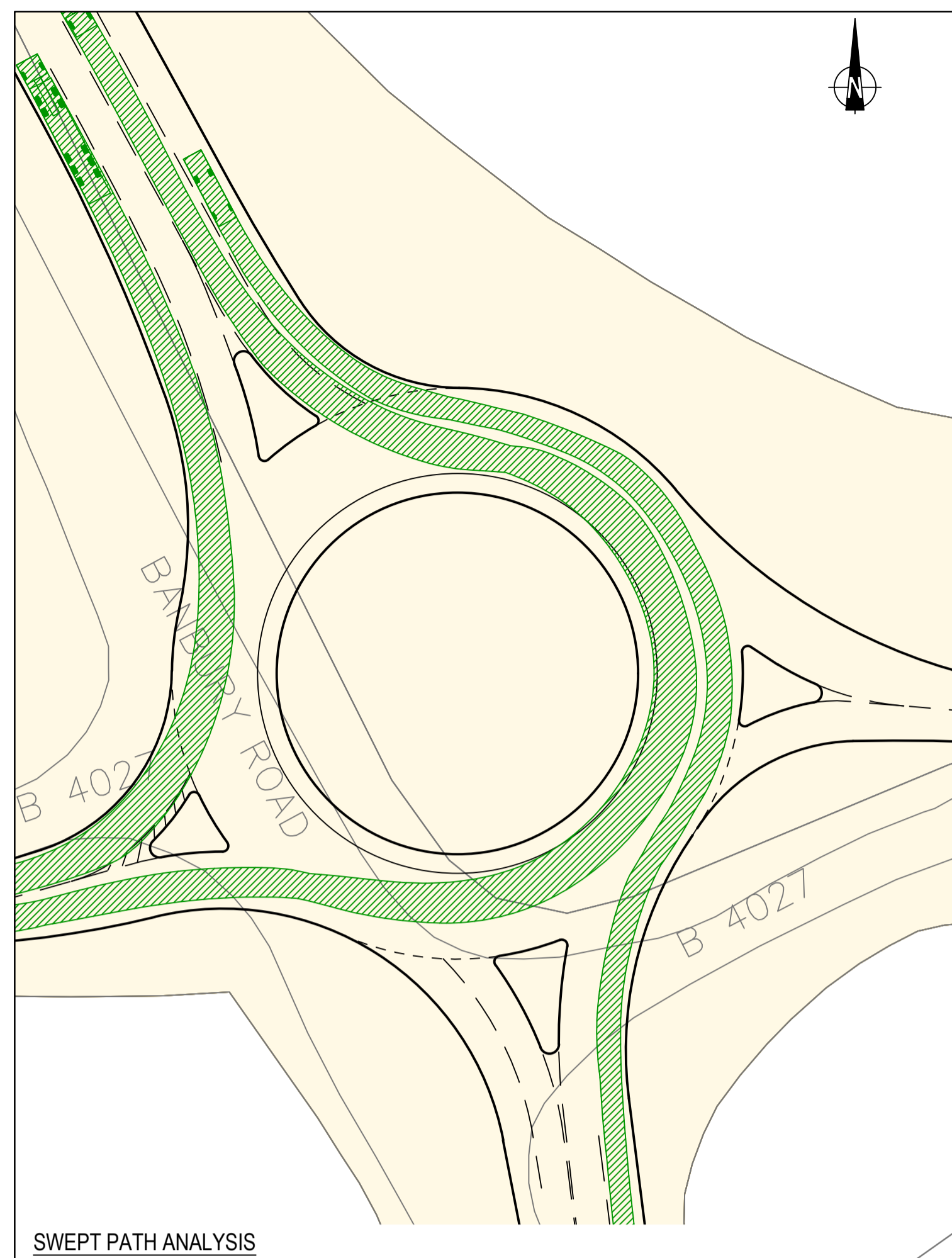

SWEPT PATH ANALYSIS  
16.5M ARTICULATED VEHICLE - OFFSIDE NORTH TO WEST MANOEUVRE & WEST TO NORTH MANOEUVRE  
7.5T BOX VAN - NEARSIDE NORTH TO SOUTH MANOEUVRE

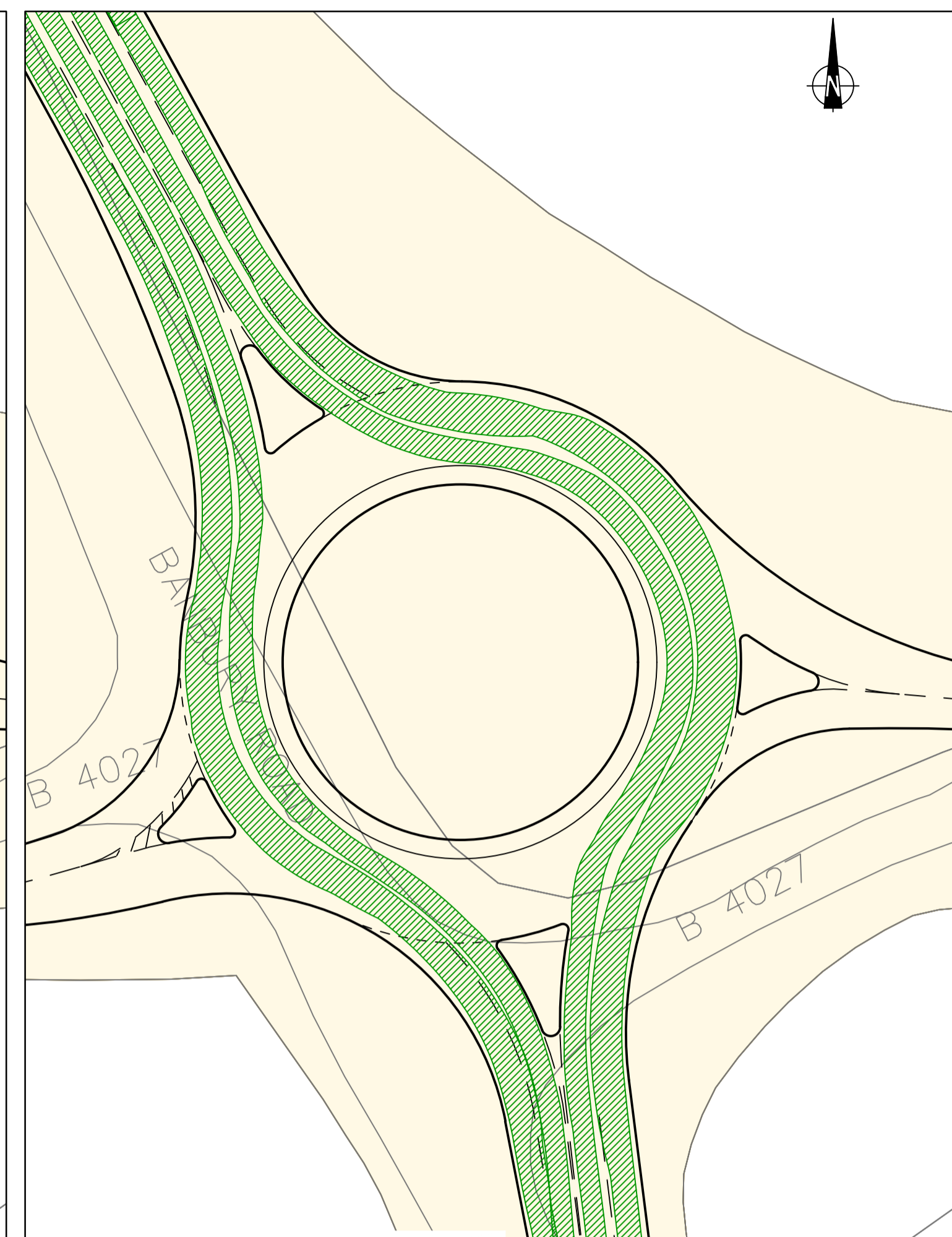

SWEPT PATH ANALYSIS  
15.0M COACH - NEARSIDE AHEAD MANOEUVRE  
7.5T BOX VAN - OFFSIDE AHEAD MANOEUVRE

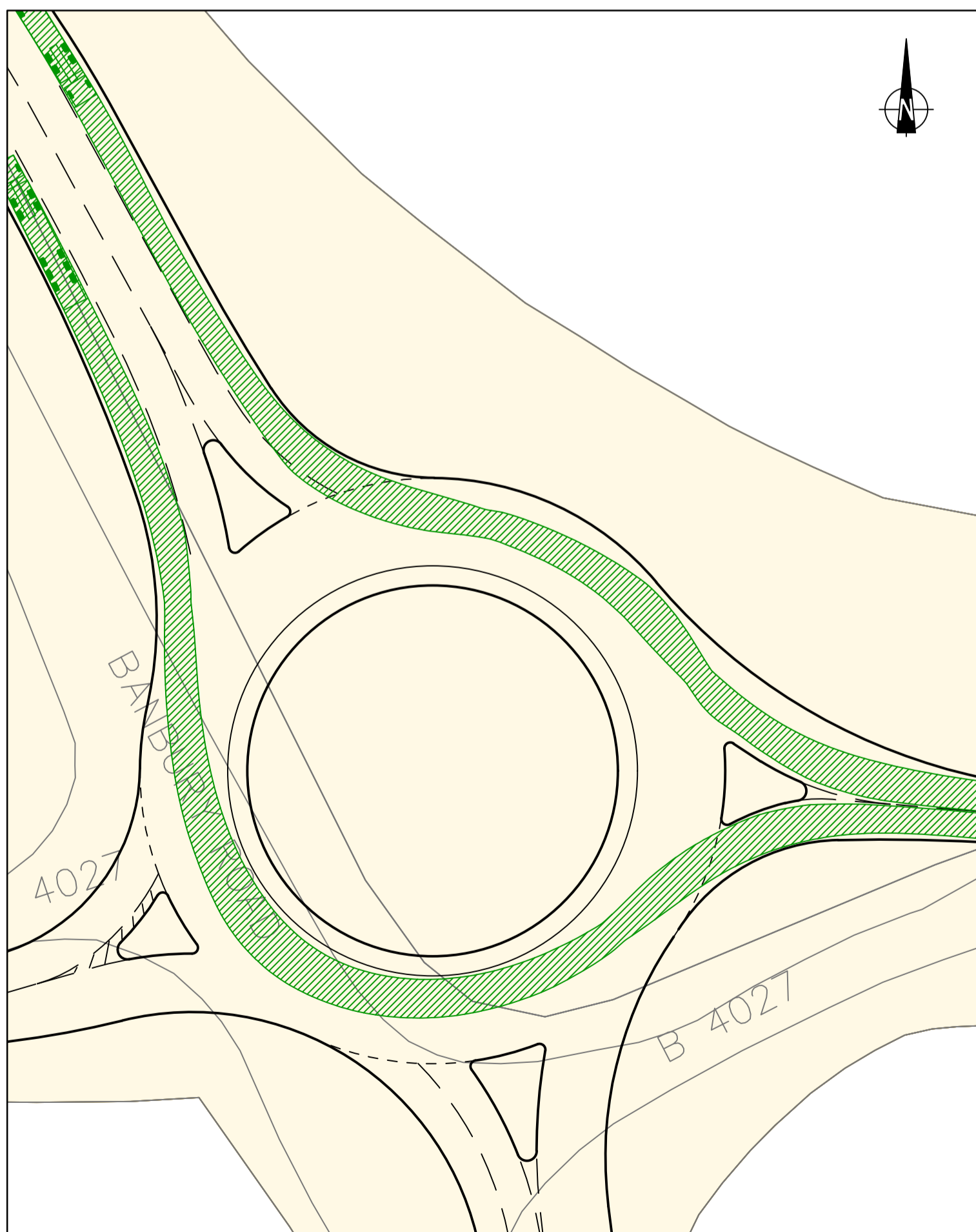

SWEPT PATH ANALYSIS  
16.5M ARTICULATED VEHICLE - NORTH TO EAST MANOEUVRE & EAST TO NORTH MANOEUVRE



SWEPT PATH ANALYSIS  
16.5M ARTICULATED VEHICLE - SOUTH TO WEST MANOEUVRE & WEST TO SOUTH MANOEUVRE

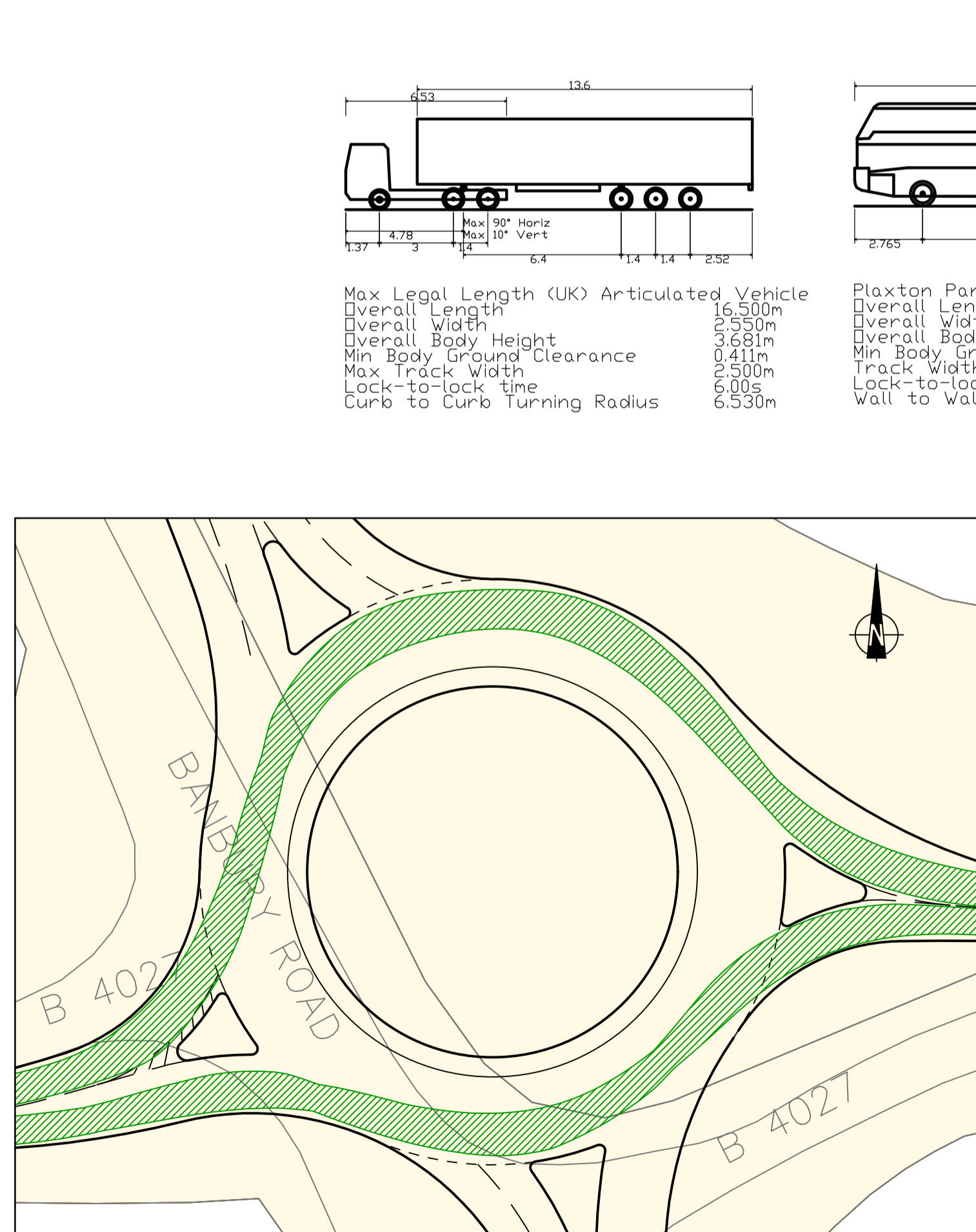

SWEPT PATH ANALYSIS  
16.5M ARTICULATED VEHICLE - EAST TO WEST TURN & WEST TO EAST MANOEUVRE

<p>Max Legal Length (UK) Articulated Vehicle 13.6m Overall Length 16.500m Overall Width 2.550m Overall Body Height 3.681m Min Body Ground Clearance 0.411m Max Track Width 2.500m Lock-to-lock time 6.00s Curb to Curb Turning Radius 6.530m</p>	<p>Plaxton Panther Bus Overall Length 15m Overall Width 2.500m Overall Body Height 4.157m Min Body Ground Clearance 0.397m Track Width 2.500m Lock-to-lock time 5.00s Wall to Wall Turning Radius 12.500m</p>	<p>7.5t Box Van Overall Length 8.010m Overall Width 2.100m Overall Body Height 3.556m Min Body Ground Clearance 0.351m Track Width 2.064m Lock-to-lock time 4.00s Curb to Curb Turning Radius 7.400m</p>

Mark	Revision	Date	Drawn	Chkd	Appd

SCALING NOTE: Do not scale from this drawing. If in doubt, ask.  
UTILITIES NOTE: The position of any existing public or private sewers, utility services, plant or apparatus shown on this drawing is believed to be correct, but no warranty to this is expressed or implied. Other such plant or apparatus may also be present but not shown. The Contractor is therefore advised to undertake his own investigation where the presence of any existing sewers, services, plant or apparatus may affect his operations.

Drawing Issue Status  
**FOR DISCUSSION**

**HEYFORD PARK, TRANCHE 2  
CONCEPT SIGNALISED JUNCTION (J18)  
POTENTIAL ROUNDABOUT MITIGATION OPTION  
SWEPT PATH ANALYSIS**

Client <b>DORCHESTER GROUP</b>			 Offices throughout the UK and Europe <b>www.peterbrett.com</b> © Peter Brett Associates LLP BRISTOL Tel: 0117 928 1560
Date of 1st Issue 15.03.18	Designed PC	Drawn PC	
A1 Scale 1:500	Checked PR	Approved -	
Drawing Number <b>39304/5501/SK46</b>		Revision -	

Reproduced from/based upon Ordnance Survey material with the permission of Ordnance Survey © on behalf of The Controller of Her Majesty's Stationery Office. © Crown Copyright. Unauthorised reproduction infringes Crown Copyright and may lead to prosecution or civil proceedings. Licence No. 0100031673 Year of Publication: 2016 Owner/Purchaser of Mapping: PBA

