

Client:
Dorchester Group

Land South-West of Camp Road, Heyford Park
Transport Assessment

2021 Reference Case Flows PCUs - AM

Date:	02/11/2016
Scale:	N.T.S
Drawn:	NK
Checked:	PR

Figure 6.11

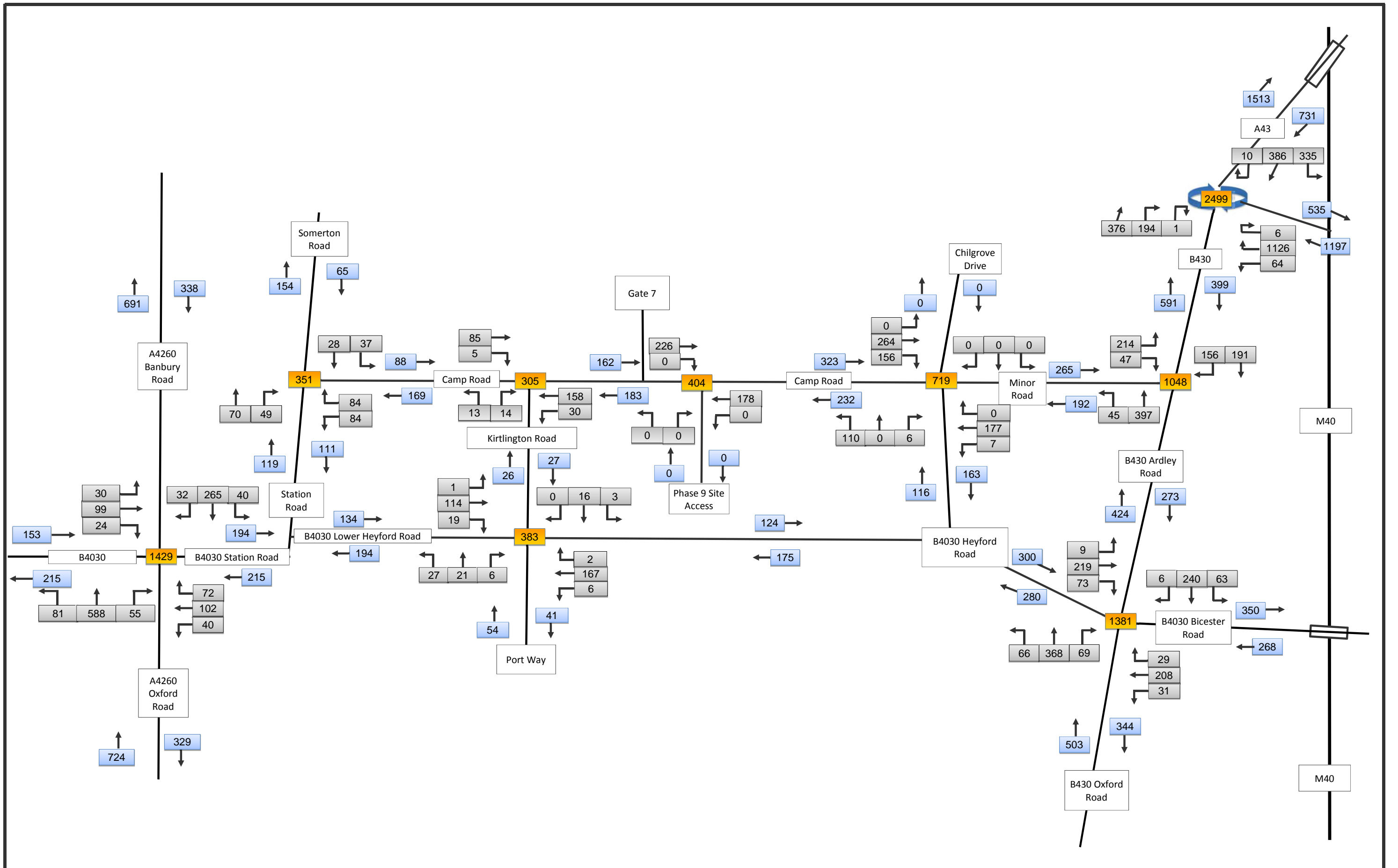

Client:
Dorchester Group

Land South-West of Camp Road, Heyford Park
Transport Assessment

2021 Reference Case Flows - Vehicles - PM

Date:	02/11/2016
Scale:	N.T.S
Drawn:	NK
Checked:	PR

Figure 6.12

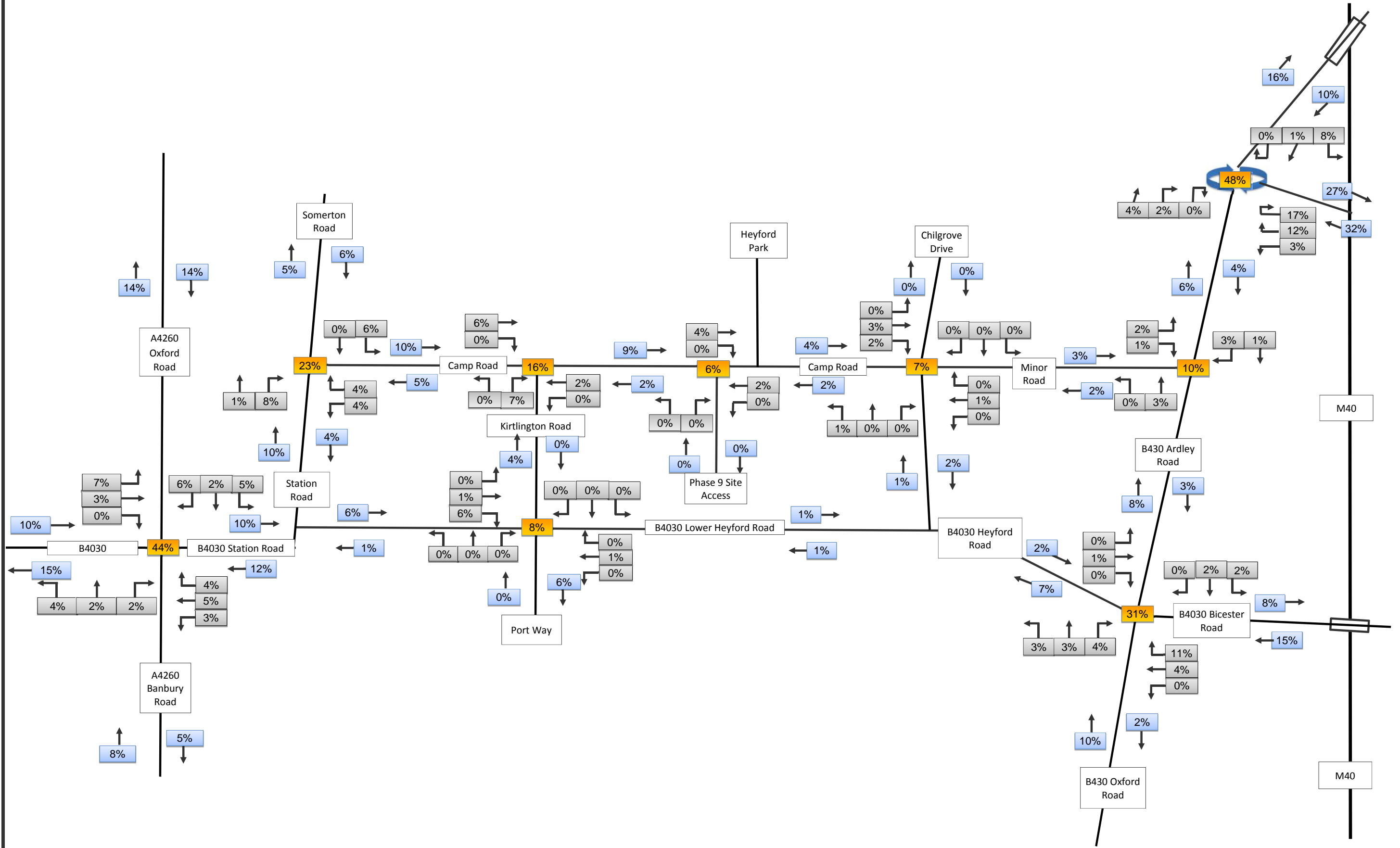

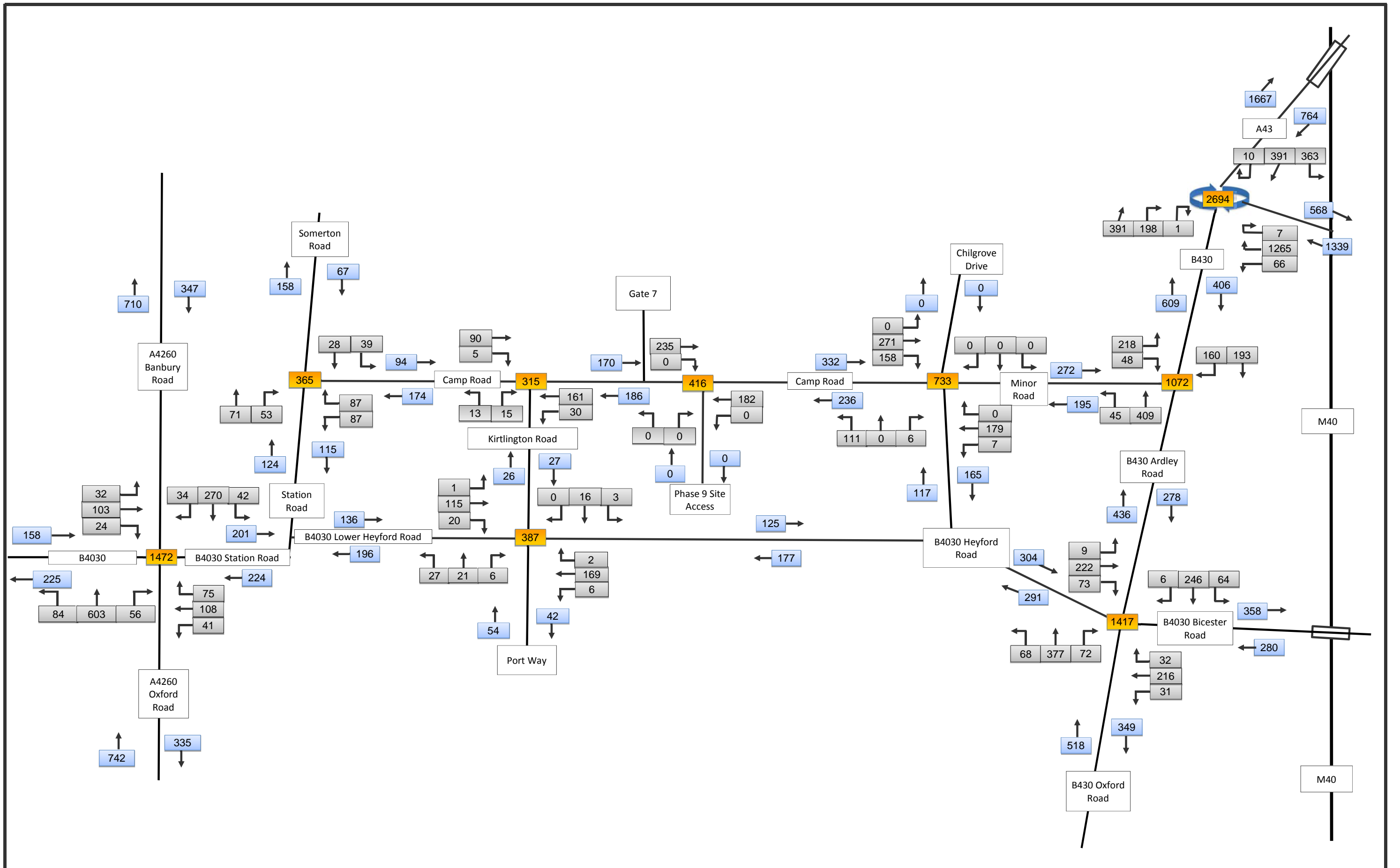

Client:
Dorchester Group

Land South-West of Camp Road, Heyford Park
Transport Assessment

2021 Reference Case Flows PCUs - PM

Date:	02/11/2016
Scale:	N.T.S
Drawn:	NK
Checked:	PR

Figure 6.14

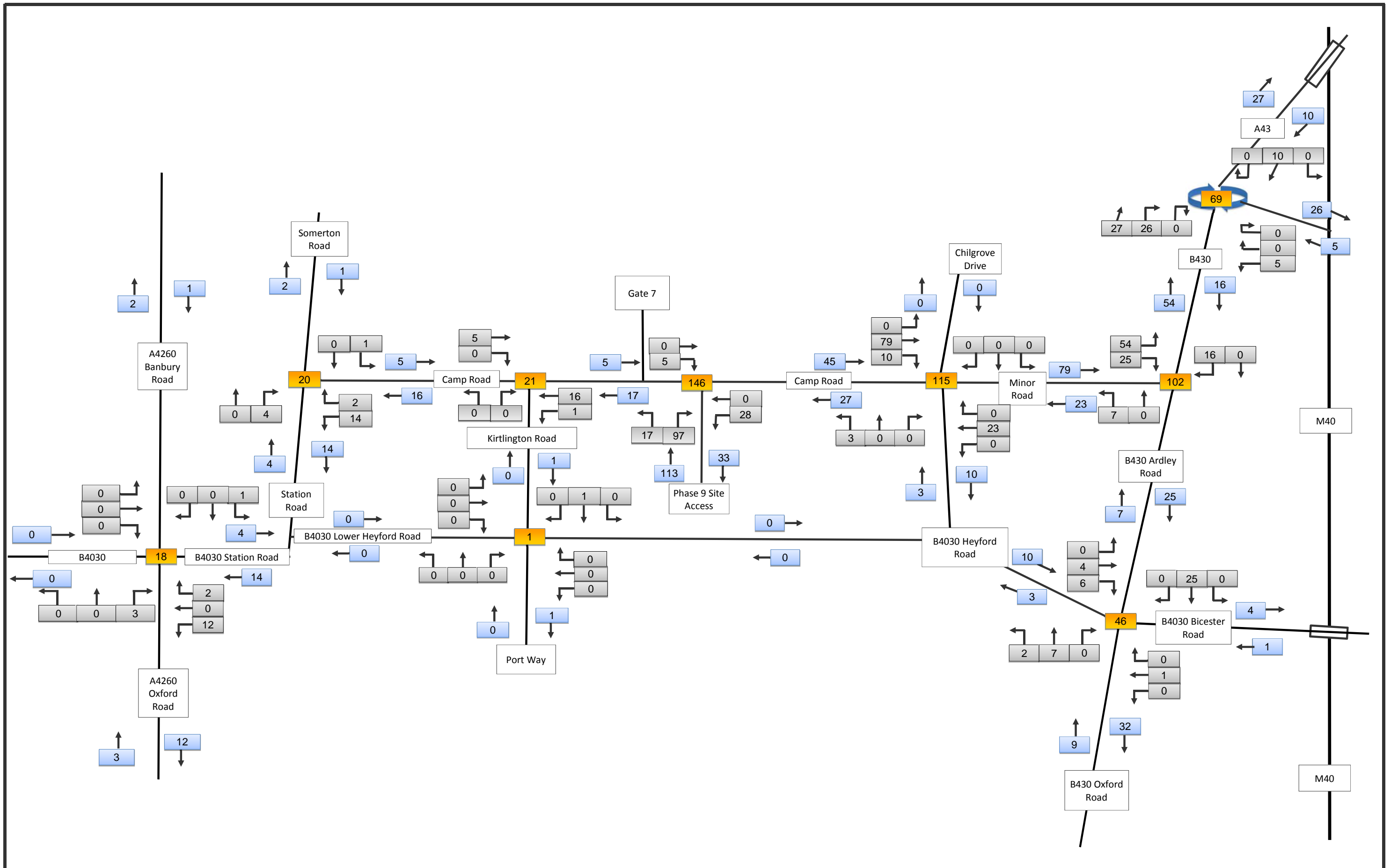

Client:
Dorchester Group

Land South-West of Camp Road, Heyford Park
Transport Assessment

Development Traffic AM Peak

Date:	02/11/2016
Scale:	N.T.S
Drawn:	NK
Checked:	PR

Figure 6.15

PETER BRETT ASSOCIATES LLP
10 QUEEN SQUARE, BRISTOL, BS1 4NT
Tel: 0117 928 1560 Fax: 0117 928 1570 E-mail: bristol@pba.co.uk
Website: www.pba.co.uk © Peter Brett Associates LLP

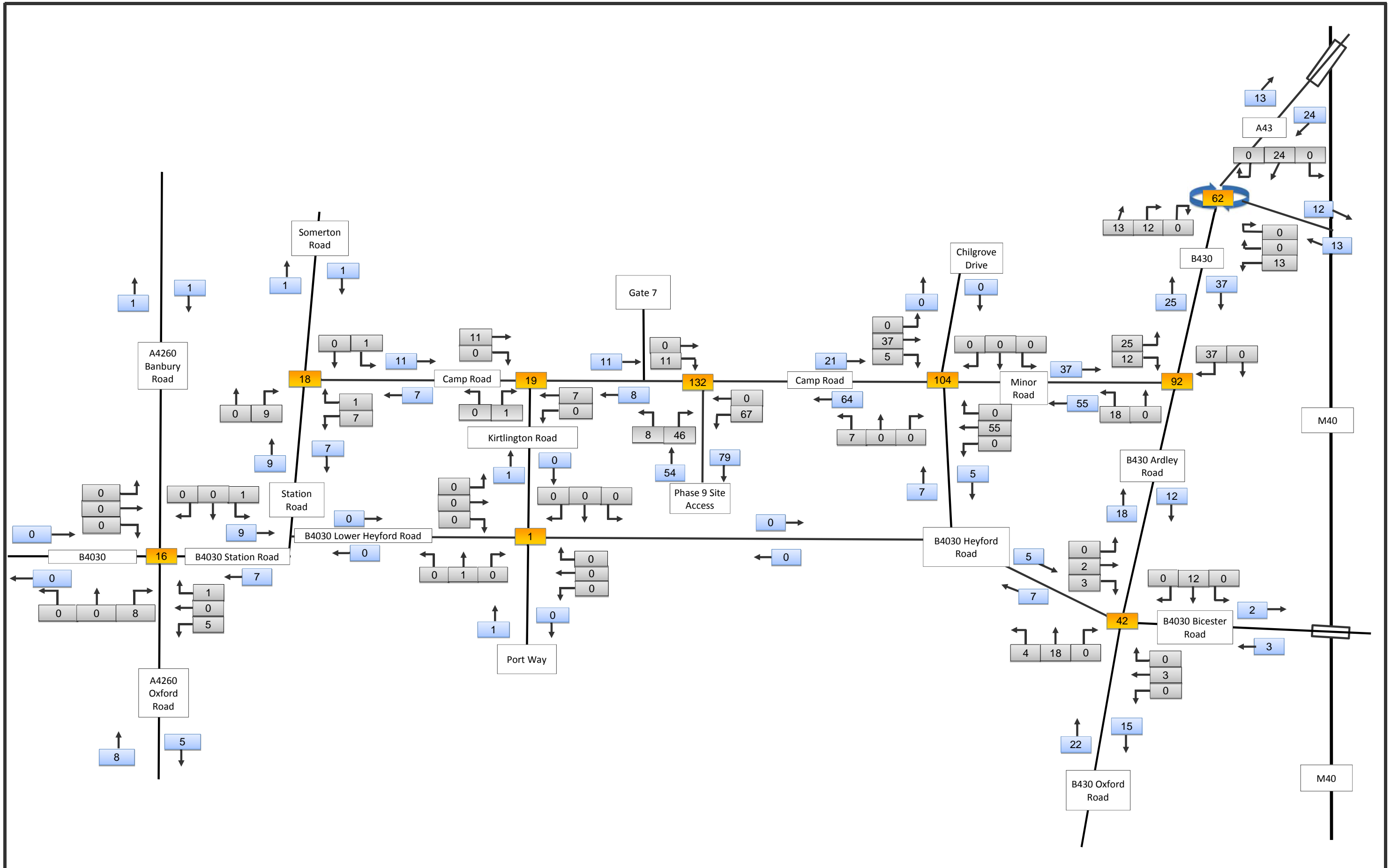

Client:
Dorchester Group

Land South-West of Camp Road, Heyford Park
Transport Assessment

Development Traffic PM Peak

Date:	02/11/2016
Scale:	N.T.S
Drawn:	NK
Checked:	PR

Figure 6.16

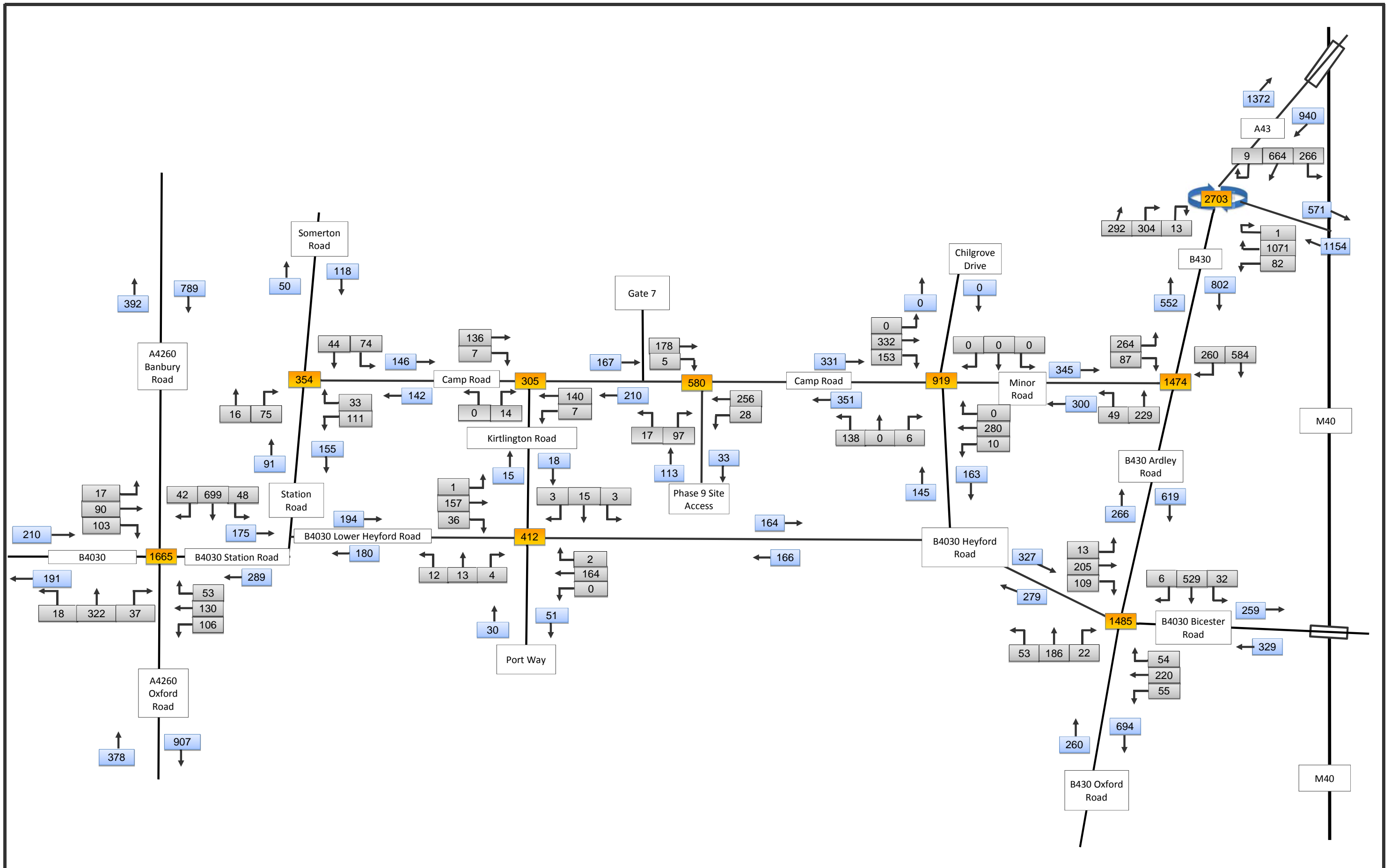

Client:
Dorchester Group

Land South-West of Camp Road, Heyford Park
Transport Assessment

2021 Test Case Flows - Vehicles - AM

Date:	02/11/2016
Scale:	N.T.S
Drawn:	NK
Checked:	PR

Figure 6.17

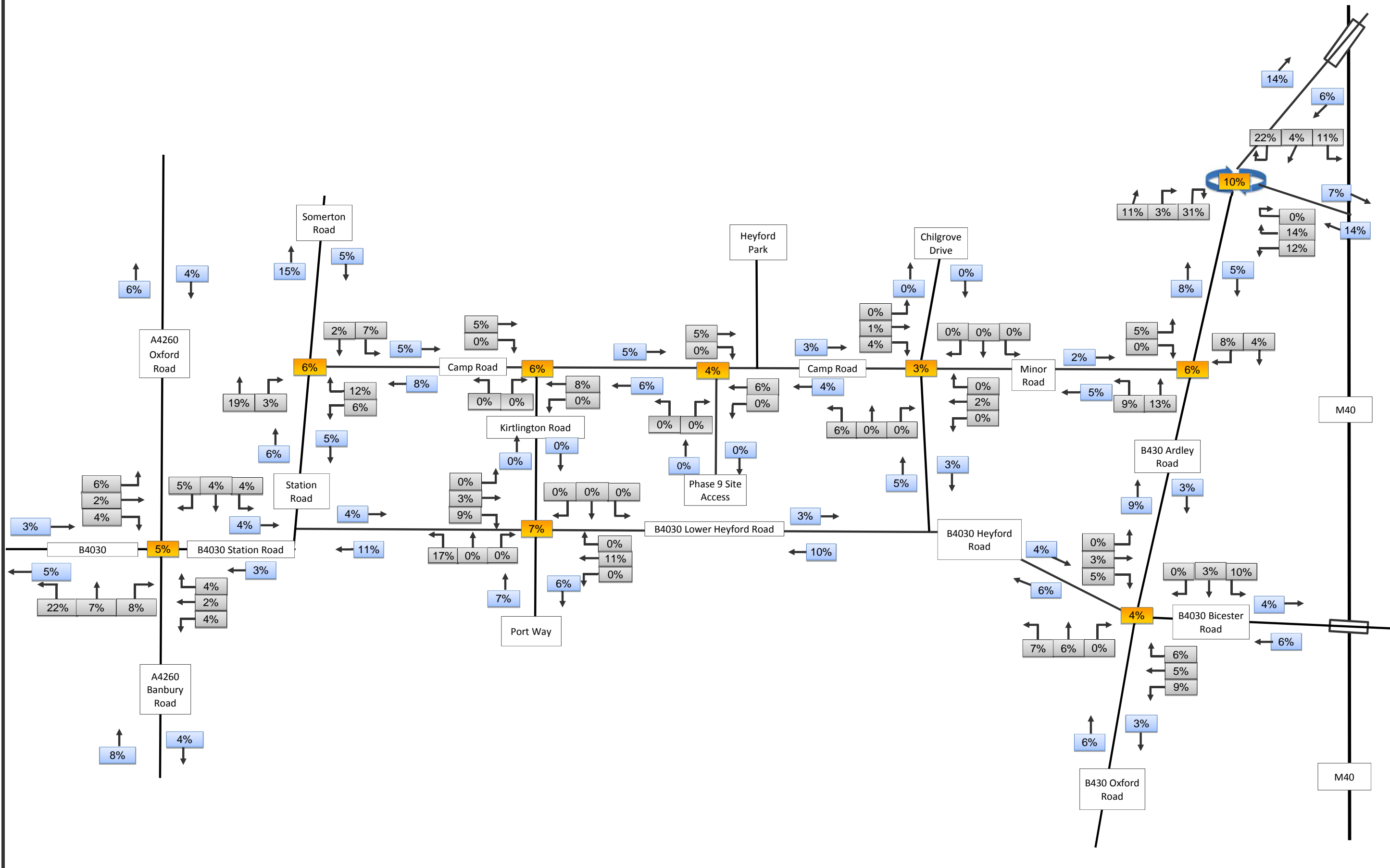

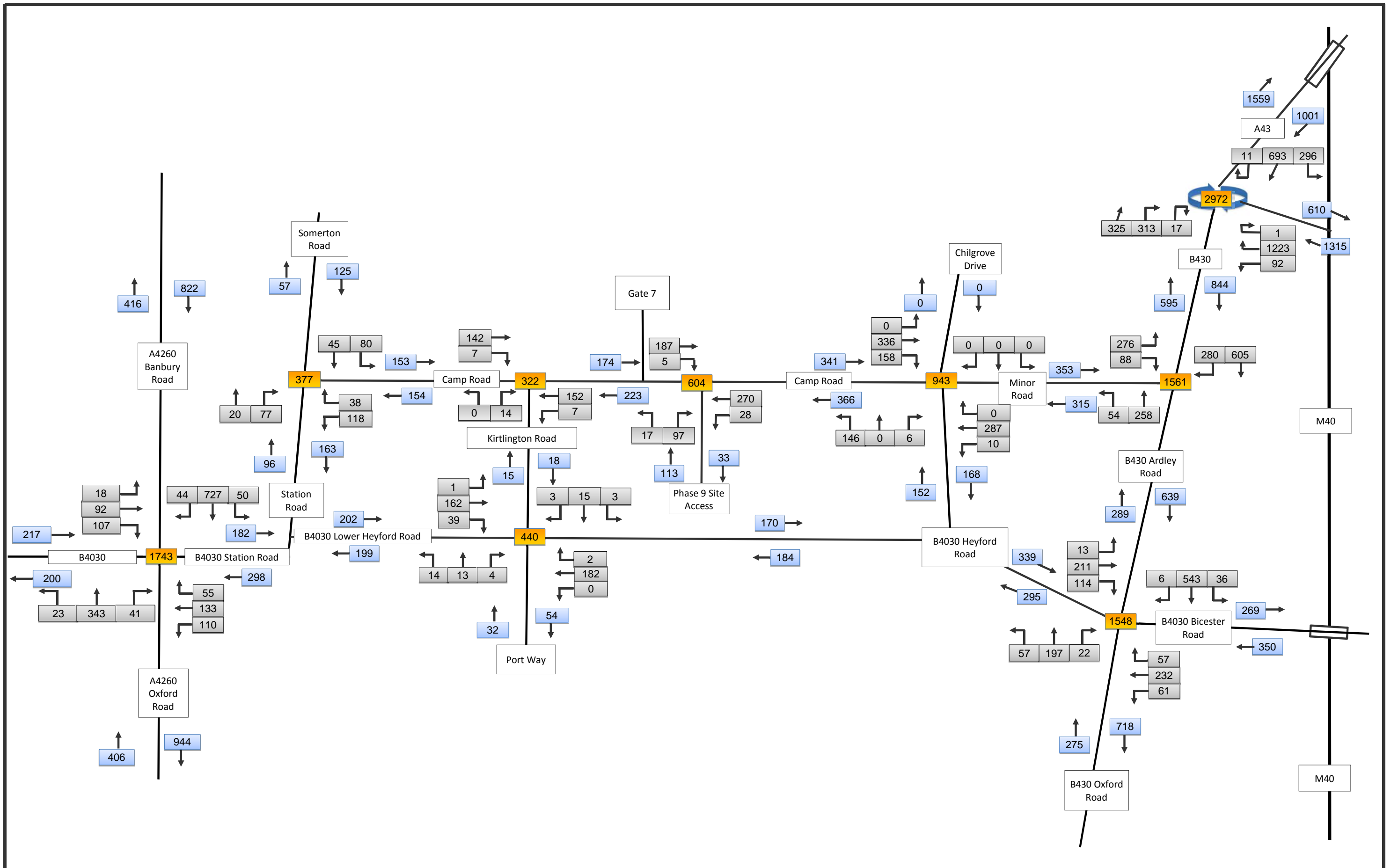

Client:
Dorchester Group

Land South-West of Camp Road, Heyford Park
Transport Assessment

2021 Test Case Flows - PCUs - AM

Date:	02/11/2016
Scale:	N.T.S
Drawn:	NK
Checked:	PR

Figure 6.19

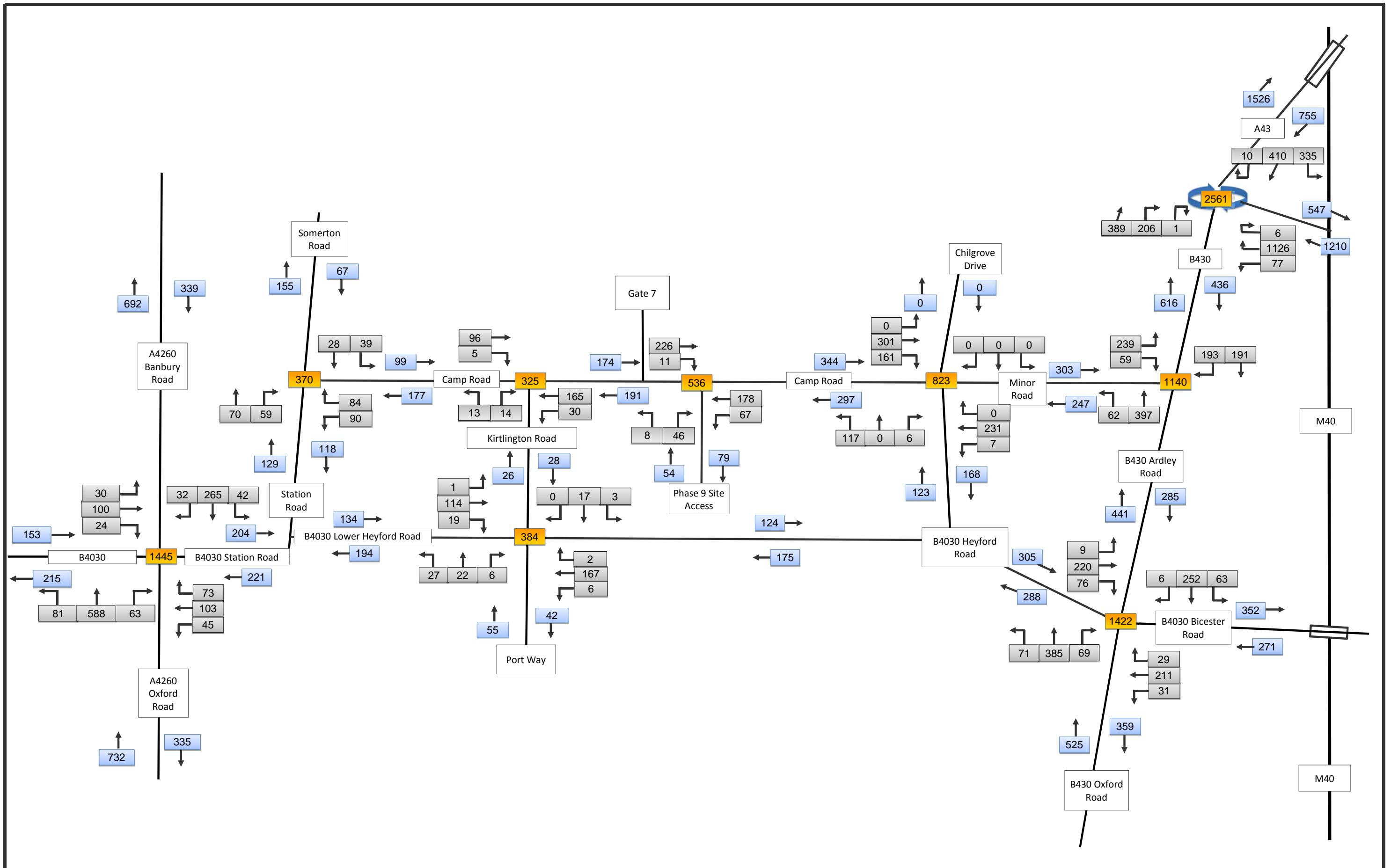

Client:
Dorchester Group

Land South-West of Camp Road, Heyford Park
Transport Assessment

2021 Test Case Flows - Vehicles - PM

Date:	02/11/2016
Scale:	N.T.S
Drawn:	NK
Checked:	PR

Figure 6.20

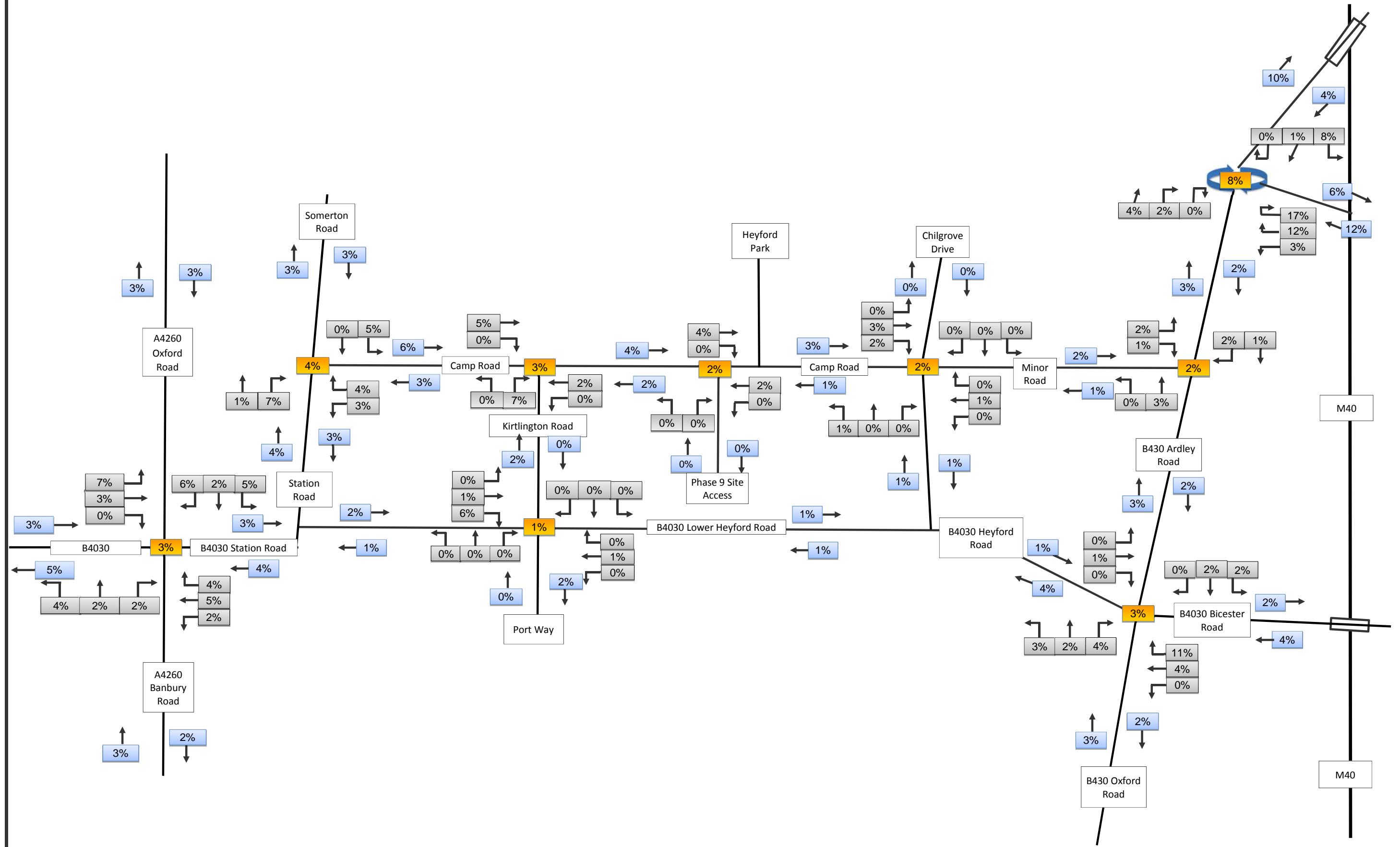

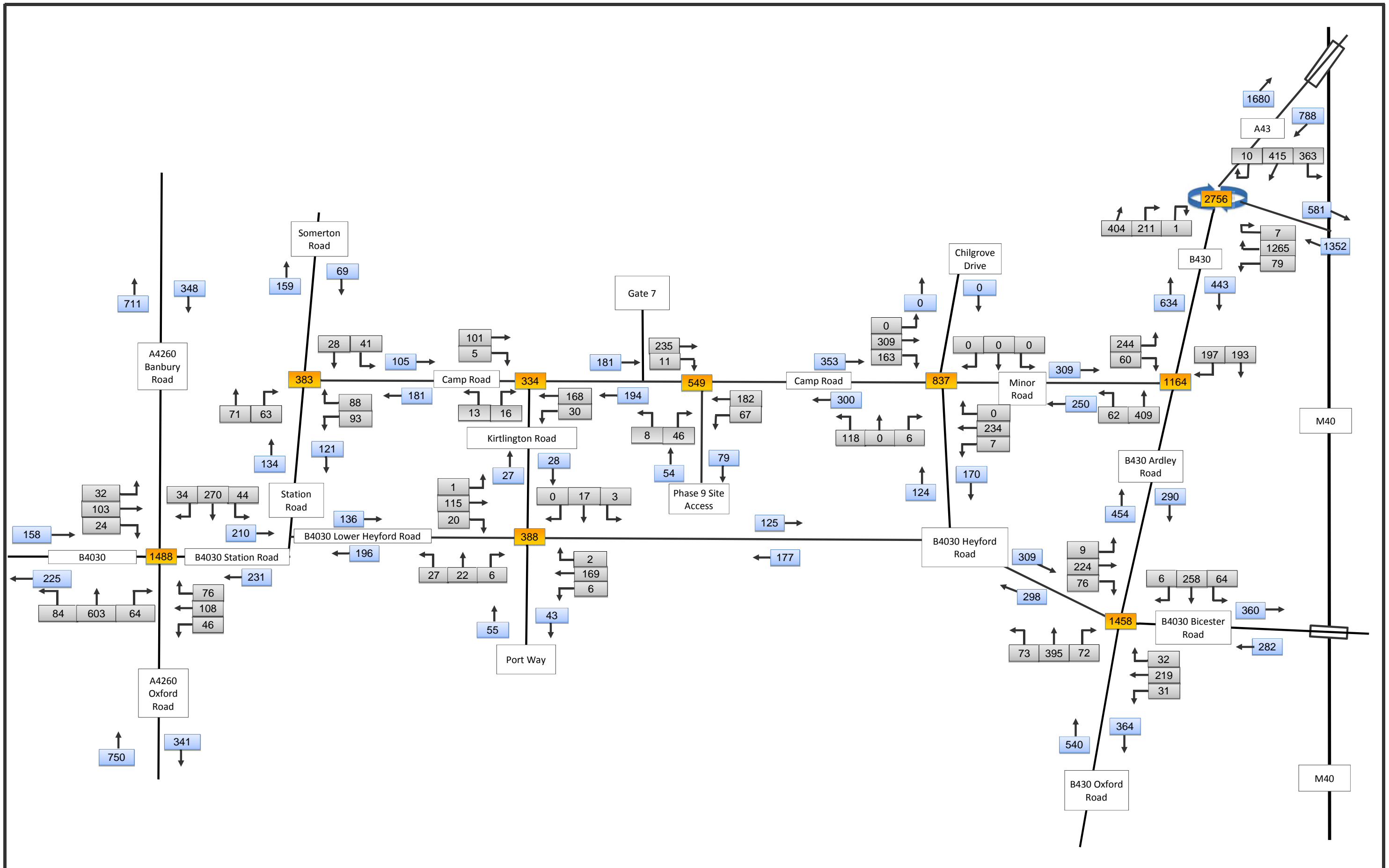

Client:
Dorchester Group

Land South-West of Camp Road, Heyford Park
Transport Assessment

2021 Test Case Flows - PCUs - PM

Date:	02/11/2016
Scale:	N.T.S
Drawn:	NK
Checked:	PR

Figure 6.22

Drawings

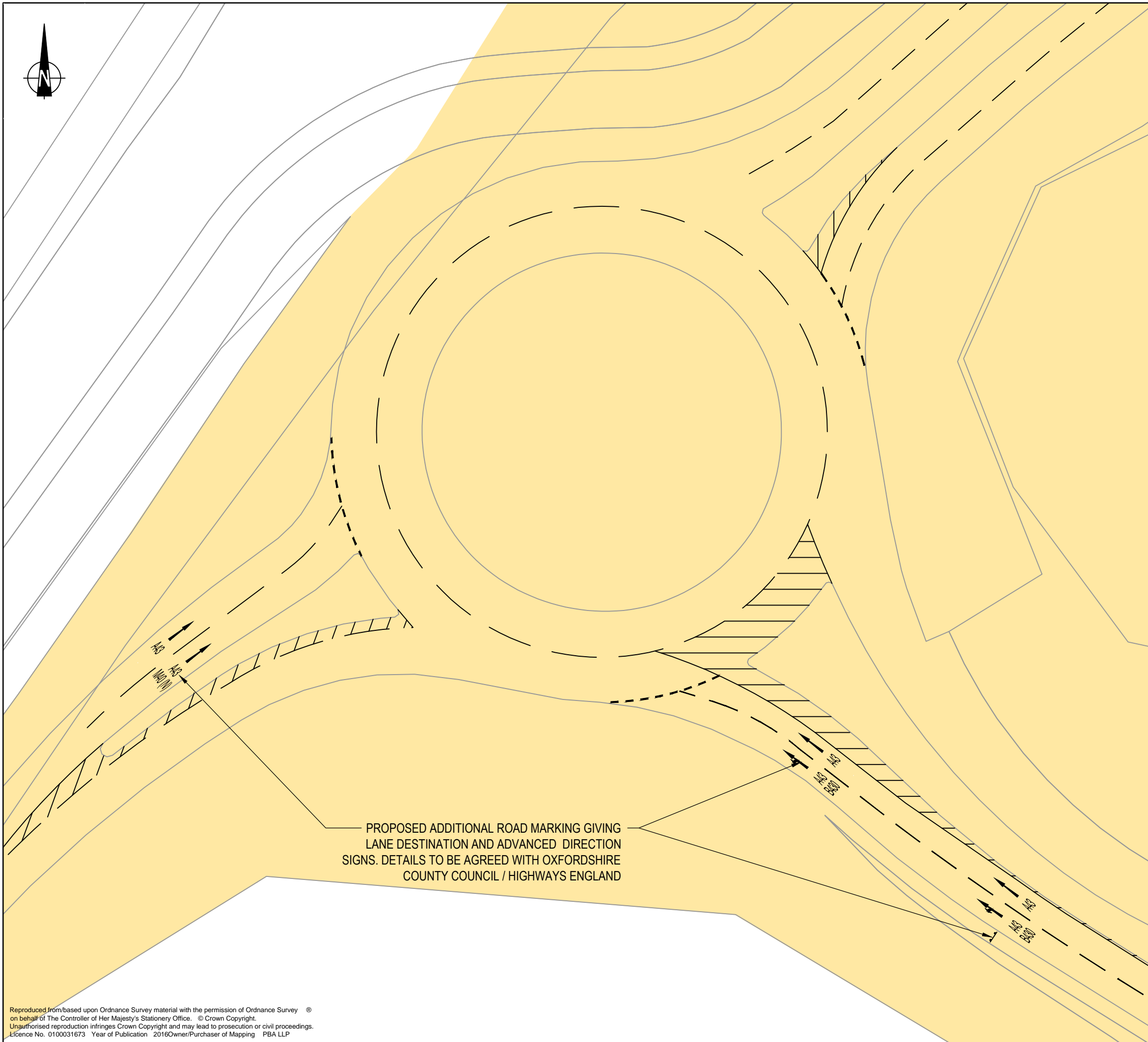

NOTES:

1. THE LAYOUT IS SUBJECT TO DETAILED DESIGN, CAPACITY TESTING, GROUND INVESTIGATIONS RESULTS & EARTHWORKS MODELLING, UTILITIES & SERVICES AND CONFIRMATION OF LAND OWNERSHIP;
2. THE DETAILED DESIGN LAYOUT WILL BE DESIGNED IN ACCORDANCE WITH ALL RELEVANT DESIGN GUIDANCE AND STANDARDS;
3. THE LAYOUT HAS BEEN BASED ON THE APPROPRIATE DESIGN SPEED FOR OUR CURRENT PROPOSALS;
4. THIS DRAWING SHOULD BE READ IN CONJUNCTION WITH ALL RELEVANT ASSOCIATED DOCUMENTS; AND
5. THE USE OF THE DRAWING DOES NOT ABSOLVE THE CLIENT FROM THEIR RESPONSIBILITIES IN REGARDS TO HEALTH & SAFETY AND CDM REGULATIONS.

KEY:

 HIGHWAY BOUNDARY INFORMATION RECEIVED FROM OXFORDSHIRE COUNTY COUNCIL ON 14.10.16 AND INTERPRETED BY PBA

Mark	Revision	Date	Drawn	Chkd	Appd

SCALING NOTE: Do not scale from this drawing. If in doubt, ask.
 UTILITIES NOTE: The position of any existing public or private sewers, utility services, plant or apparatus shown on this drawing is believed to be correct, but no warranty to this is expressed or implied. Other such plant or apparatus may also be present but not shown. The Contractor is therefore advised to undertake his own investigation where the presence of any existing sewers, services, plant or apparatus may affect his operations.

Drawing Issue Status **CONCEPT**

**AND SOUTH-WEST OF CAMP ROAD,
 HEYFORD PARK
 ARDLEY ROUNDABOUT
 PROPOSED IMPROVEMENTS**

Client
**DORCHESTER
 GROUP**

Date of 1st Issue 03.10.2016	Designed JHo	Drawn JHo
A3 Scale 1:500	Checked PR	Approved -

Drawing Number
33374/5511/001



Offices throughout the UK and Europe
www.peterbrett.com
 © Peter Brett Associates LLP
 BRISTOL
 Tel: 0117 928 1560

Reproduced from/based upon Ordnance Survey material with the permission of Ordnance Survey © on behalf of The Controller of Her Majesty's Stationery Office. © Crown Copyright. Unauthorised reproduction infringes Crown Copyright and may lead to prosecution or civil proceedings. Licence No. 0100031673 Year of Publication 2016 Owner/Purchaser of Mapping PBA LLP

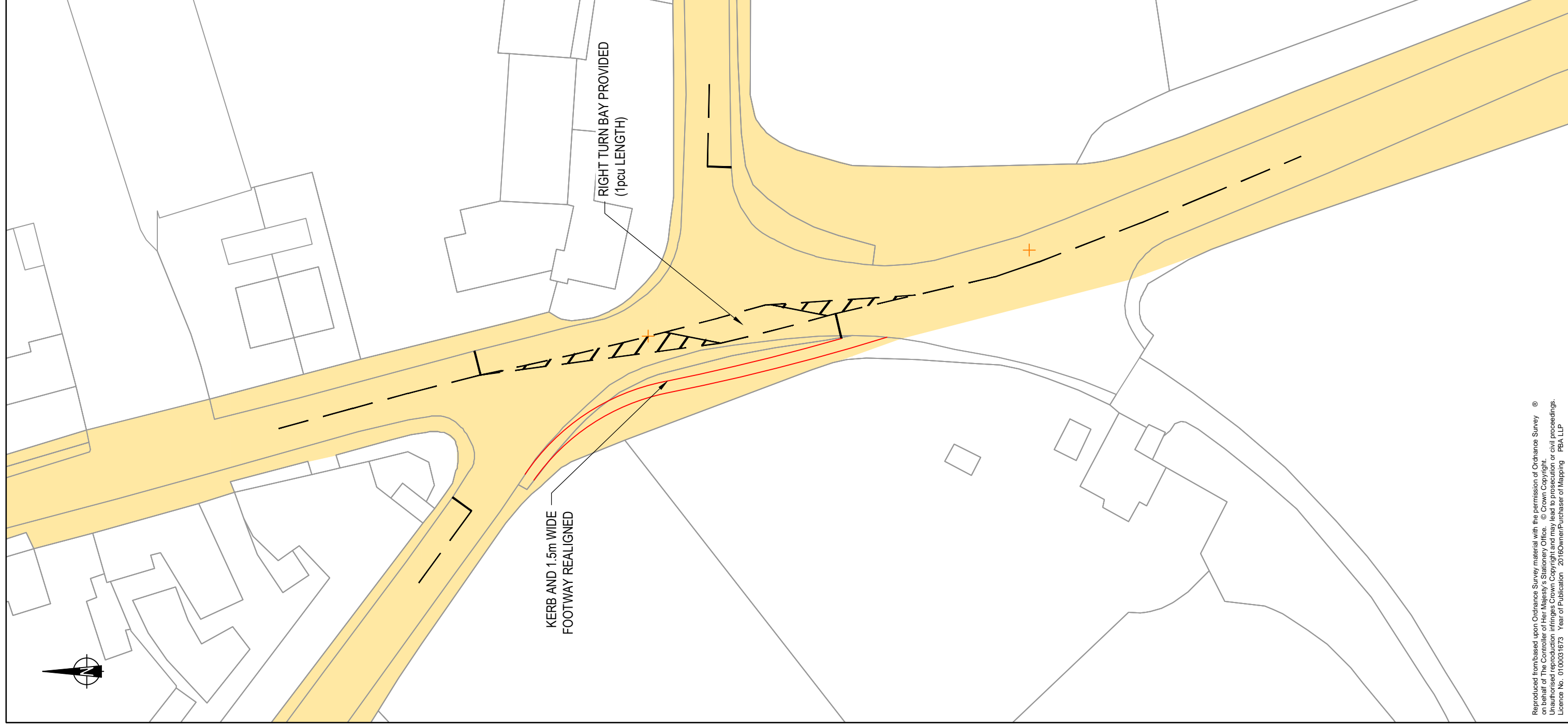

NOTES:

1. THE LAYOUT IS SUBJECT TO DETAILED DESIGN, CAPACITY TESTING, GROUND INVESTIGATIONS RESULTS & EARTHWORKS MODELLING, UTILITIES & SERVICES AND CONFIRMATION OF LAND OWNERSHIP;
2. THE DETAILED DESIGN LAYOUT WILL BE DESIGNED IN ACCORDANCE WITH ALL RELEVANT DESIGN GUIDANCE AND STANDARDS;
3. THE LAYOUT HAS BEEN BASED ON THE APPROPRIATE DESIGN SPEED FOR OUR CURRENT PROPOSALS;
4. THIS DRAWING SHOULD BE READ IN CONJUNCTION WITH ALL RELEVANT ASSOCIATED DOCUMENTS;
5. THE USE OF THE DRAWING DOES NOT ABSOLVE THE CLIENT FROM THEIR RESPONSIBILITIES IN REGARDS TO HEALTH & SAFETY AND CDM REGULATIONS; AND
6. HIGHWAY ALIGNMENT SUBJECT TO FURTHER TOPOGRAPHICAL SURVEY AND LEVEL INFORMATION.

KEY:

 HIGHWAY BOUNDARY INFORMATION RECEIVED FROM OXFORDSHIRE COUNTY COUNCIL ON 24.10.16 AND INTERPRETED BY PBA

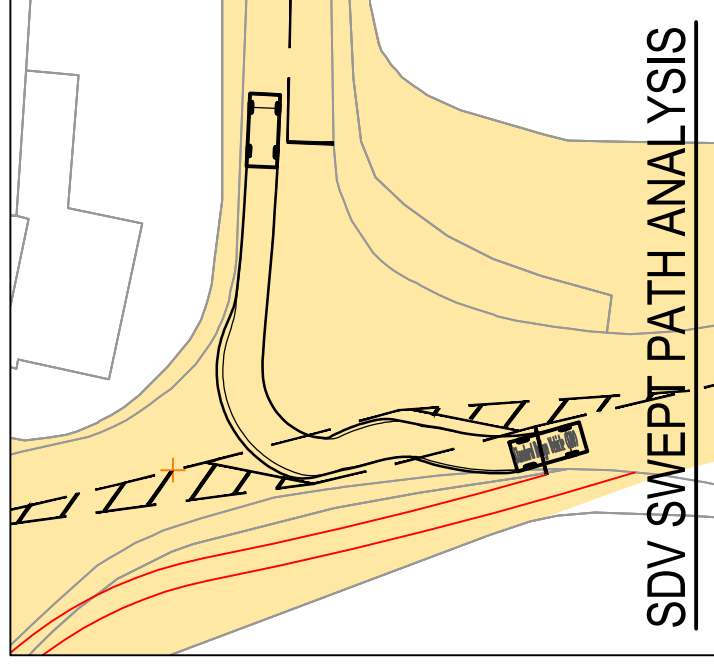

SDV SWEEP PATH ANALYSIS

Mark	Revision	Date	Drawn	Chkd	Appd

SCALING NOTE: Do not scale from this drawing. If in doubt, ask UTILITIES NOTE: The position of any existing public or private sewers, utility services, plant or apparatus shown on this drawing is believed to be correct, but no warranty to this is expressed or implied. Other such plant or apparatus may also be present but not shown. The Contractor is therefore advised to undertake his own investigation where the presence of any existing sewers, services, plant or apparatus may affect his operations.

FOR INFORMATION

**LAND SOUTH-WEST OF CAMP ROAD,
 HEYFORD PARK
 MIDDLETON STONEY JUNCTION
 PROPOSED MITIGATION SCHEME**

Client
DORCHESTER GROUP

Date of 1st Issue	Designed	Drawn	Revision
03/10/2016	KWM	KWM	-
A3 Scale	1:500	Checked SK	Approved PR
Drawing Number	33374/5511/002		



Reproduced from based upon Ordnance Survey material with the permission of Ordnance Survey on behalf of The Controller of Her Majesty's Stationery Office. © Crown Copyright. Unauthorised reproduction infringes Crown Copyright and may lead to prosecution or civil proceedings. Licence No. 0100031673 Year of Publication 2016 Owner/Purchaser of Mapping PBA LLP

Appendix A Parameter Plan



- KEY:**
- APPLICATION AREA (12.04HA)
 - RESIDENTIAL LAND USE (8.90HA INC. GREEN CORRIDORS)
 - PUBLIC OPEN SPACE PROVISION (ALLOTMENT PROVISION ASSUMED OFF SITE. INCLUDES ATTENUATION AREA) (2.90HA)
 - ACCESS POINTS
 - CAMP ROAD
 - IZZARD DRIVE
 - PRIMARY SPACE
 - SECONDARY SPACE
 - PRINCIPAL ROUTE
 - MEWS / SHARED SURFACE
 - LANE
 - CYCLEWAY
 - PEDESTRIAN FOOTPATH
 - GREEN CORRIDIOR
 - NEIGHBOURHOOD EQUIPPED AREA OF PLAY
 - LOCAL EQUIPPED AREA OF PLAY
 - LOCAL AREA OF PLAY
 - TRIM TRAIL
 - EXISTING PORTWAY ROUTE
 - EXISTING VEGETATION TO BE RETAINED
 - INDICATIVE ENHANCEMENT VEGETATION
 - ATTENUATION POND
 - 3 STOREY DWELLINGS TO BE CIRCA 13M HEIGHT ABOVE FINISHED GROUND LEVEL
THE REMAINDER WILL BE 2/2.5 STOREY DWELLINGS AT UP TO CIRCA 11.5M HEIGHT ABOVE FINISHED GROUND LEVEL

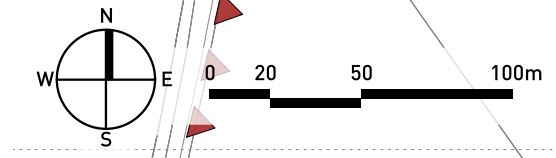

NOTE:
GROUND LEVEL ALLOWS FOR MAXIMUM 2M +/- EXISTING GROUND LEVEL, THIS ESTABLISHES APPROPRIATE DRAINAGE, BALANCE CUT & FILL AND BUILDING/ROAD ALIGNMENT TO CONSISTENT LEVEL.

OPEN LAND MAY INCLUDE ELEMENTS OF GROUND REGRADING AND MOUNDING.

4.1 FIGURE
Parameter Plan TITLE

1:2500 @ A3 SCALE
D.0358_04M DWG. NO.

Appendix B Planning Layout

PHASE 9, HEYFORD PARK, UPPER HEYFORD, BICESTER

This drawing is the property of Focus, O.D. Design which is a trading name for Focus Design Partnerships Limited. No liability will be accepted for amendments by others to either the printed or digital format.



Symbol	Description
[Green square]	Grass
[Light green square]	Grass (shaded)
[Dark green square]	Grass (dark)
[Blue square]	Water
[Grey square]	Concrete
[Brown square]	Asphalt
[Yellow square]	Path
[Red square]	Boundary
[Black square]	Building Footprint
[Circle]	Tree
[Triangle]	Light
[Square]	Garage
[Star]	Play Area
[Diamond]	Drainage
[Hexagon]	Other

ACCOMMODATION SCHEDULE	
APARTMENT	NO. OF UNITS
1. 1 Bed	10
2. 2 Bed	20
3. 3 Bed	30
4. 4 Bed	40
5. 5 Bed	50
6. 6 Bed	60
7. 7 Bed	70
8. 8 Bed	80
9. 9 Bed	90
10. 10 Bed	100
11. 11 Bed	110
12. 12 Bed	120
13. 13 Bed	130
14. 14 Bed	140
15. 15 Bed	150
16. 16 Bed	160
17. 17 Bed	170
18. 18 Bed	180
19. 19 Bed	190
20. 20 Bed	200
21. 21 Bed	210
22. 22 Bed	220
23. 23 Bed	230
24. 24 Bed	240
25. 25 Bed	250
26. 26 Bed	260
27. 27 Bed	270
28. 28 Bed	280
29. 29 Bed	290
30. 30 Bed	300
31. 31 Bed	310
32. 32 Bed	320
33. 33 Bed	330
34. 34 Bed	340
35. 35 Bed	350
36. 36 Bed	360
37. 37 Bed	370
38. 38 Bed	380
39. 39 Bed	390
40. 40 Bed	400
41. 41 Bed	410
42. 42 Bed	420
43. 43 Bed	430
44. 44 Bed	440
45. 45 Bed	450
46. 46 Bed	460
47. 47 Bed	470
48. 48 Bed	480
49. 49 Bed	490
50. 50 Bed	500
51. 51 Bed	510
52. 52 Bed	520
53. 53 Bed	530
54. 54 Bed	540
55. 55 Bed	550
56. 56 Bed	560
57. 57 Bed	570
58. 58 Bed	580
59. 59 Bed	590
60. 60 Bed	600
61. 61 Bed	610
62. 62 Bed	620
63. 63 Bed	630
64. 64 Bed	640
65. 65 Bed	650
66. 66 Bed	660
67. 67 Bed	670
68. 68 Bed	680
69. 69 Bed	690
70. 70 Bed	700
71. 71 Bed	710
72. 72 Bed	720
73. 73 Bed	730
74. 74 Bed	740
75. 75 Bed	750
76. 76 Bed	760
77. 77 Bed	770
78. 78 Bed	780
79. 79 Bed	790
80. 80 Bed	800
81. 81 Bed	810
82. 82 Bed	820
83. 83 Bed	830
84. 84 Bed	840
85. 85 Bed	850
86. 86 Bed	860
87. 87 Bed	870
88. 88 Bed	880
89. 89 Bed	890
90. 90 Bed	900
91. 91 Bed	910
92. 92 Bed	920
93. 93 Bed	930
94. 94 Bed	940
95. 95 Bed	950
96. 96 Bed	960
97. 97 Bed	970
98. 98 Bed	980
99. 99 Bed	990
100. 100 Bed	1000

PLANNING LAYOUT

Appendix C Woods Hardwick Camp Road Proposals

