

KEY

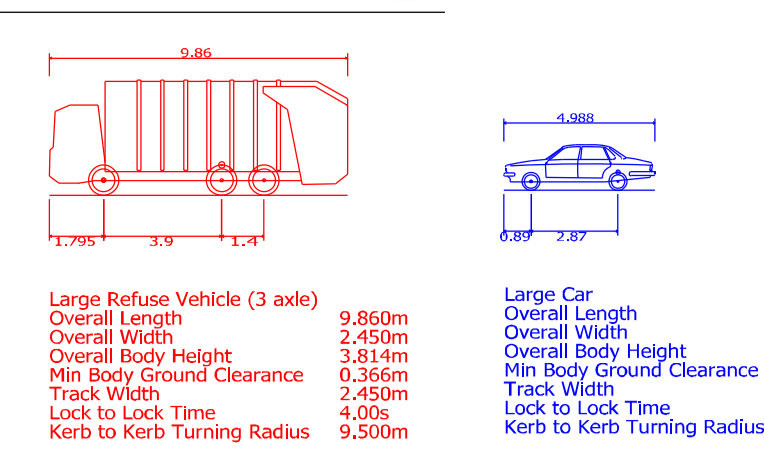

NOTES

1. CONTRACTORS MUST CHECK ALL DIMENSIONS ON SITE. ONLY FIGURED DIMENSIONS ARE TO BE WORKED FROM. DISCREPANCIES MUST BE REPORTED TO THE ARCHITECT OR ENGINEER BEFORE PROCEEDING. © THIS DRAWING IS COPYRIGHT.
2. REPRODUCED FROM OS SITEMAP © BY PERMISSION OF ORDNANCE SURVEYS ON BEHALF OF THE CONTROLLER OF HER MAJESTY'S STATIONERY OFFICE. © CROWN COPYRIGHT 2008. ALL RIGHTS RESERVED. LICENCE NUMBER 10007126.
3. UNTIL TECHNICAL APPROVAL HAS BEEN OBTAINED FROM THE RELEVANT AUTHORITIES, ALL DRAWINGS ARE ISSUED AS PRELIMINARY AND NOT FOR CONSTRUCTION. SHOULD THE CONTRACTOR COMMENCE SITE WORK PRIOR TO APPROVAL BEING GIVEN IT IS ENTIRELY AT HIS OWN RISK.

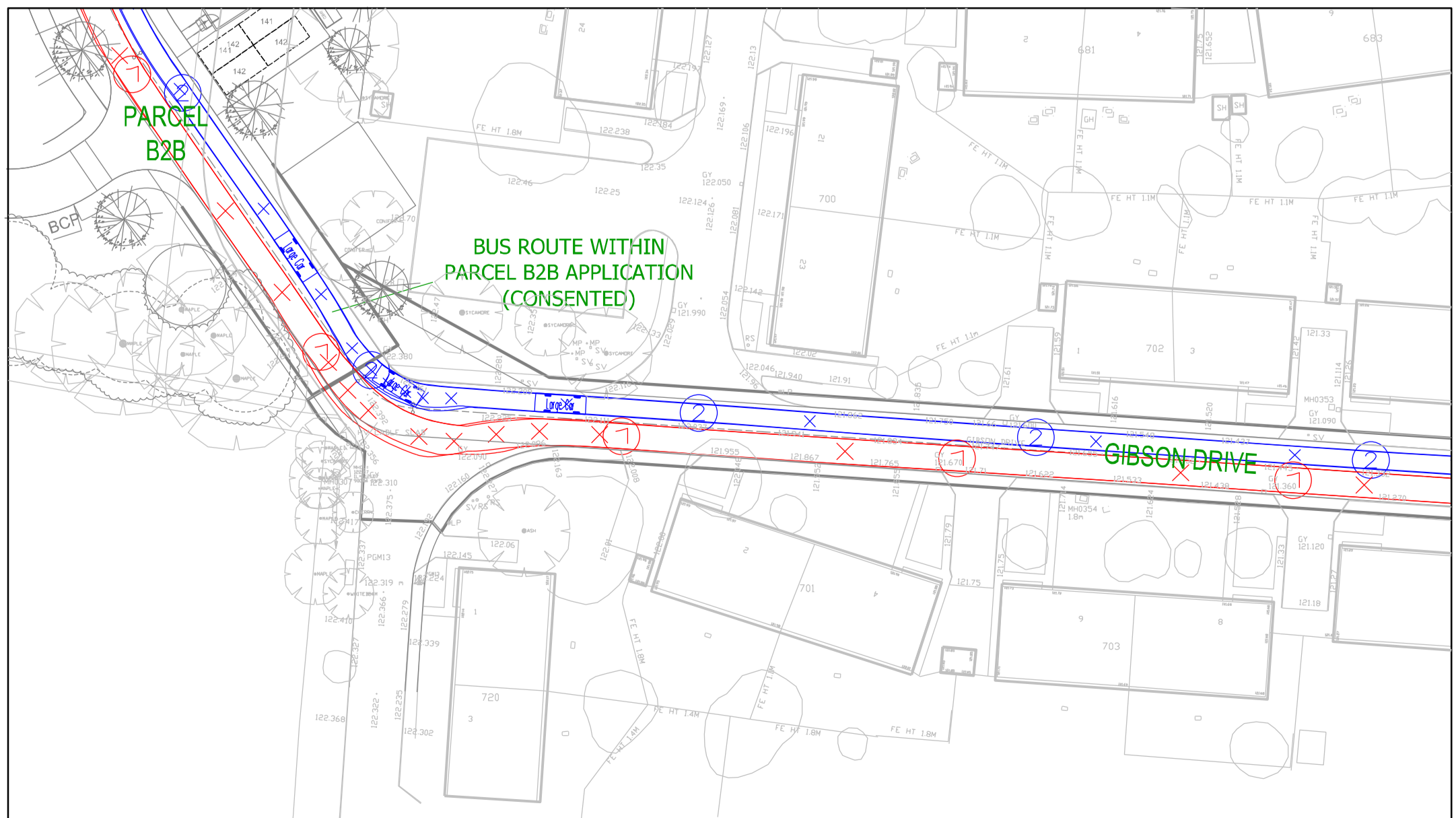
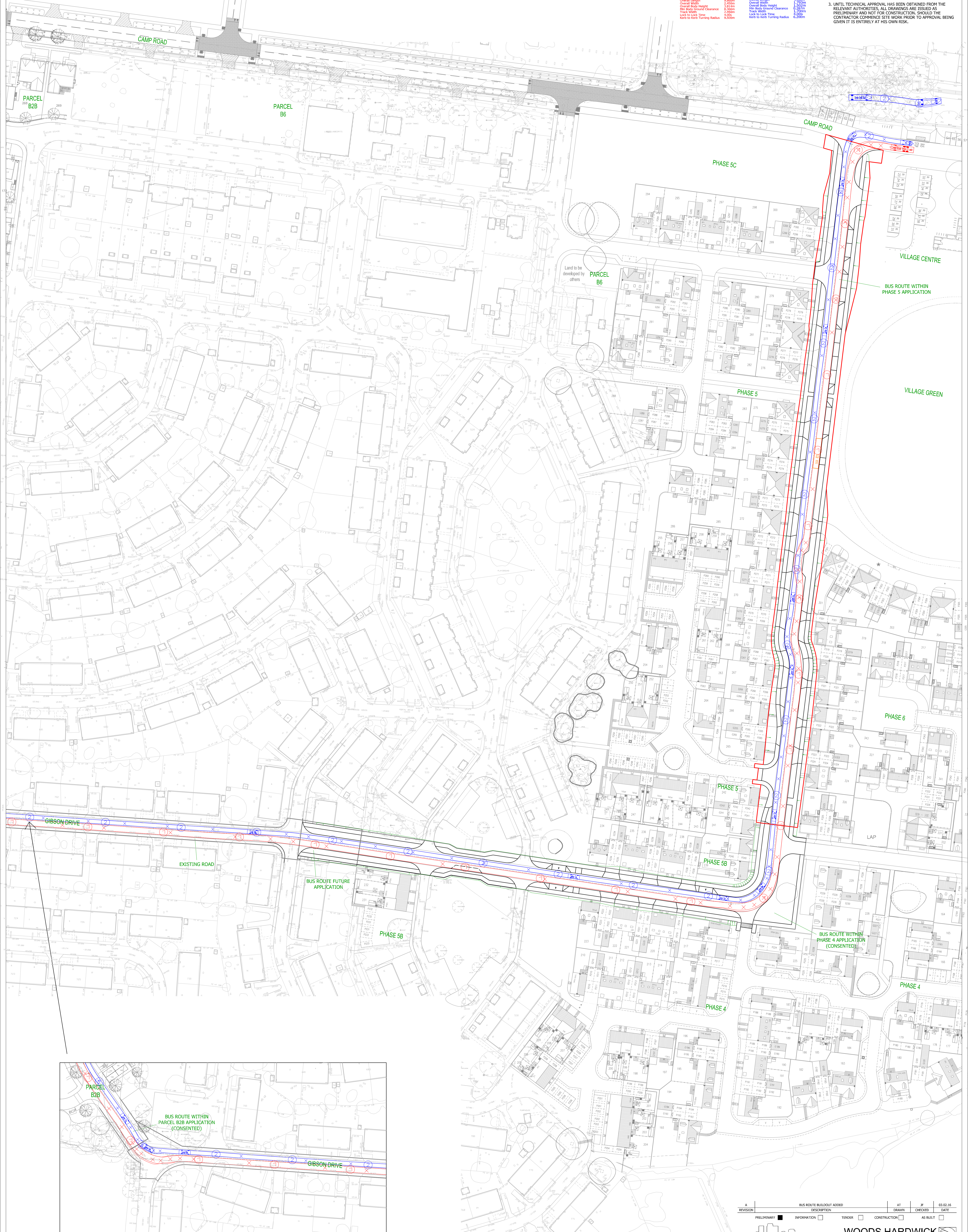

REVISION	DESCRIPTION	AT	BY	DATE
A	BUS ROUTE BUILDOUT ADDED			03.02.16

**WOODS HARDWICK**  
ARCHITECTS, ENGINEERS AND DEVELOPMENT CONSULTANTS

TITLE: UPPER HEYFORD RMA2 BUS ROUTE  
DETAILS: REFUSE TRACKING

SCALE: A0-1:500 DATE: JANUARY 2016 DRAWN: AT CHK: JF

15-17 COLCHESTER ROAD, BISHOP CADDISBURY, LEICESTER, LE19 1RQ  
TEL: 01533 440000 FAX: 01533 440001  
WWW.WOODSHARDWICK.COM

HEYF-5-762 A