

- Contractors must check all dimensions on site. Only figured dimensions are to be worked from. Discrepancies must be reported to the Architect or Engineer before proceeding. © This drawing is copyright
- Reproduced from OS Sitemap © by permission of Ordnance Survey® on behalf of The Controller of Her Majesty's Stationary Office. © Crown copyright 2008. All rights reserved. Licence number 100007126.

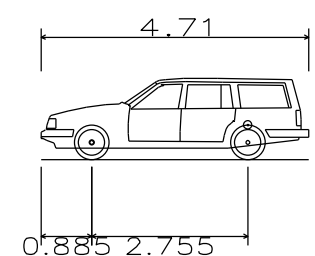

Estate Car (2006)
 Overall Length 4.710m
 Overall Width 1.804m
 Overall Body Height 1.442m
 Min Body Ground Clearance 0.207m
 Max Track Width 1.756m
 Lock to Lock Time 4.00s
 Kerb to Kerb Turning Radius 5.950m

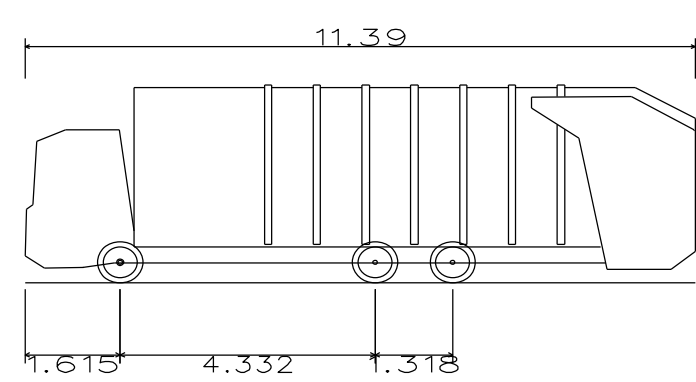

OL-23W 6x2 RS
 Overall Length 11.390m
 Overall Width 2.530m
 Overall Body Height 2.699m
 Min Body Ground Clearance 0.251m
 Track Width 2.00m
 Lock to Lock Time 7.00s
 Kerb to Kerb Turning Radius 7.500m

Revision	Description	Drawn	Checked	Date
B	Estate car tracking added to drive on parcel B1	AT	JF	14.07.14
A	Latest architects layout shown	AT	JF	07.07.14

Preliminary Information Tender Construction As Built

Woods Hardwick
 Architects, Engineers and Development Consultants

15-17 Goldington Road
 Bedford
 MK40 3NH
 United Kingdom
 T. +44 (0)1234 268862
 F. +44 (0)1234 253034
 mail@woods-hardwick.com
 www.woods-hardwick.com

Title: UPPER HEYFORD PARCELS B1 AND B2a
 Details: TRACKING LAYOUT
 Scale: A1-1:500 Date: DECEMBER 2013 Drawn: AT Chk: JF