

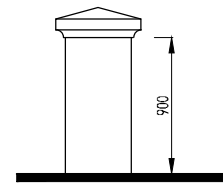

REVISION/S:

- A. 2016-05-03. Timber access gate description changed to 1800mm high timber matchboard access gate and retractable bollard added. PVA



900mm High Pier

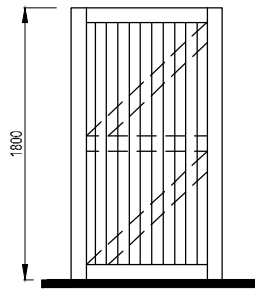

1800mm High Timber Matchboard Access Gate

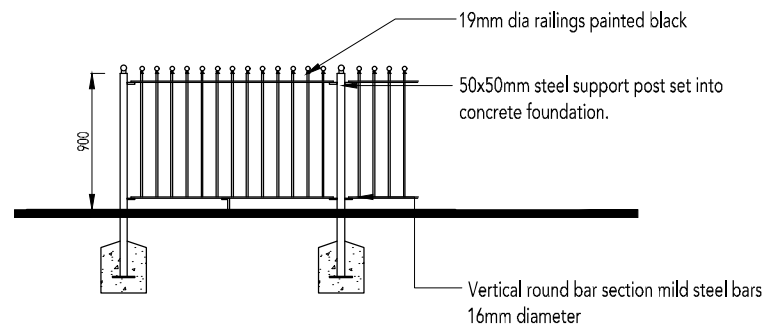

900mm High Estate Railings

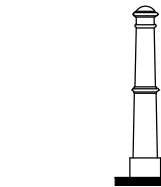

Retractable Metal Bollard

PLEASE NOTE:

MATERIALS TO SCREEN WALLS & MASONRY PIERS TO BE INDICATED ON MATERIALS LAYOUT DRG NO: 0521-PH5-108.

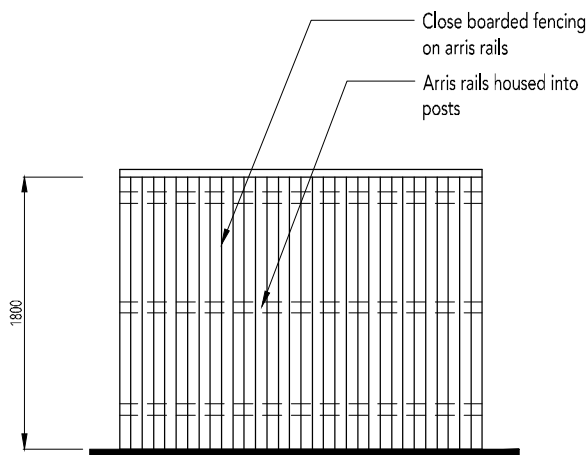

1800mm High Close Board Fence

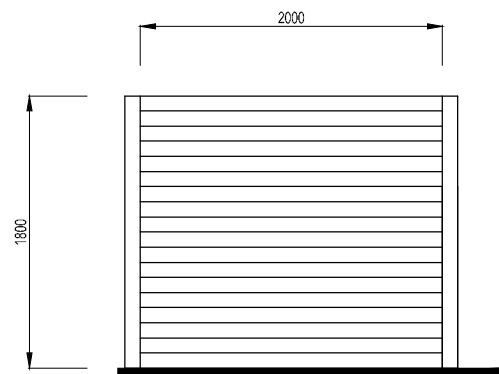

1800mm High Plot Division Panel Fence

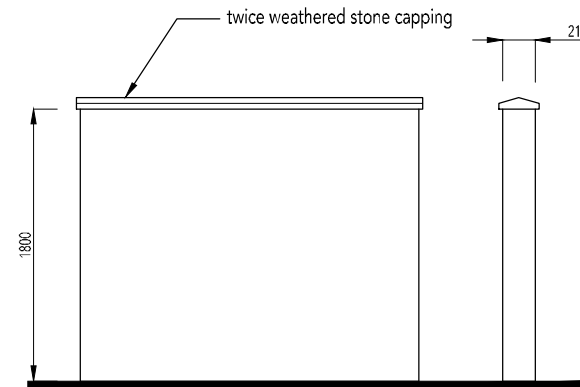

1800mm High Screen Wall

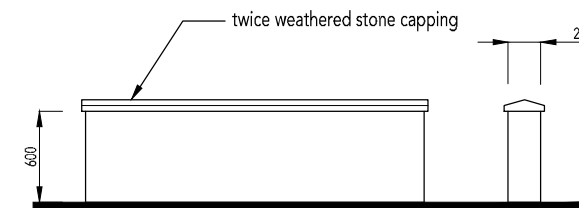

600mm High Screen Wall

