

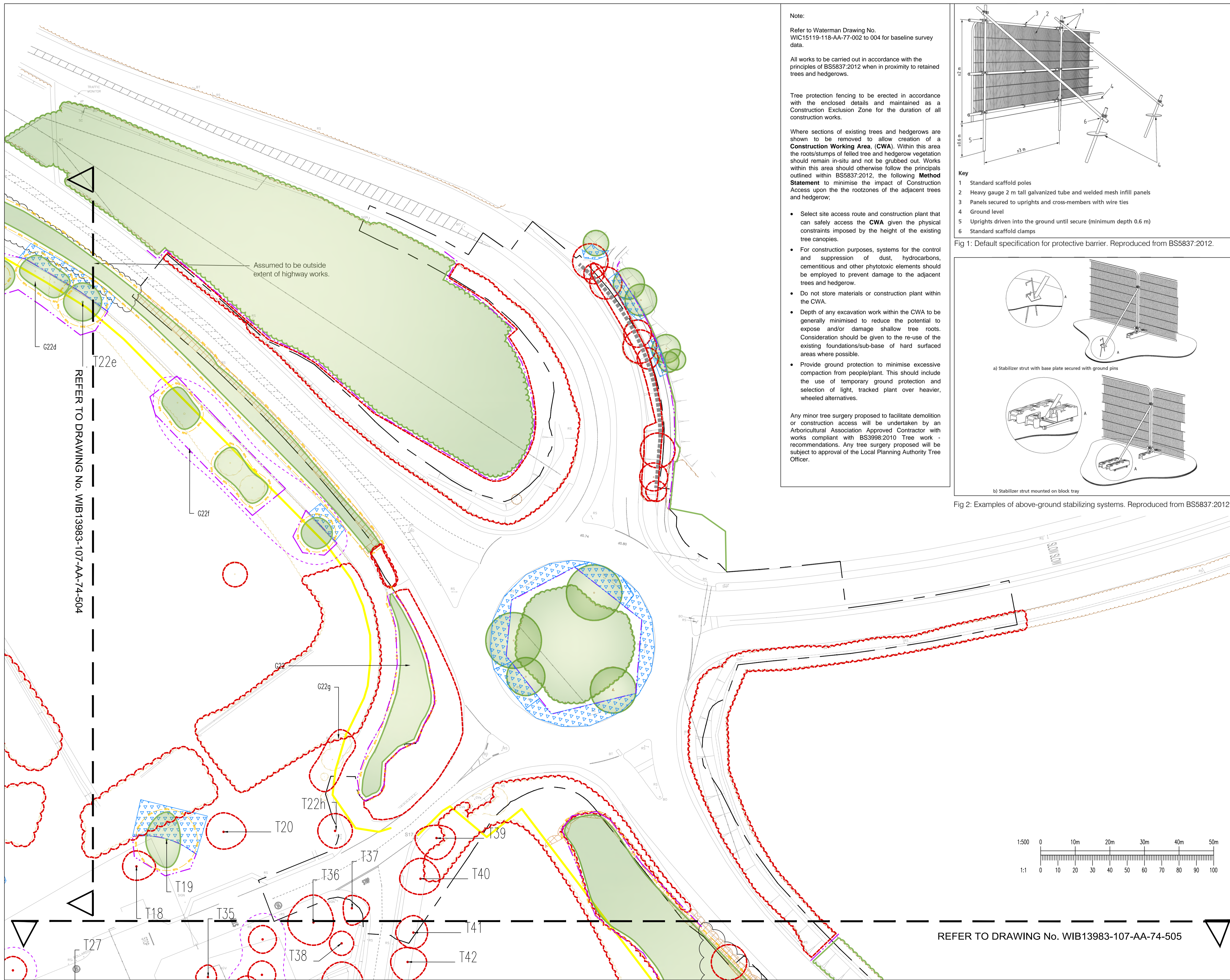

Drawing 3: LTA 1 Tree and Habitat Protection Plan Sheets 1 of 12, Waterman Drawings
WIB13983-107-AA-74-503 to -514



Note:
 Refer to Waterman Drawing No. WIC15119-118-AA-77-002 to 004 for baseline survey data.

All works to be carried out in accordance with the principles of BS5837:2012 when in proximity to retained trees and hedgerows.

Tree protection fencing to be erected in accordance with the enclosed details and maintained as a Construction Exclusion Zone for the duration of all construction works.

Where sections of existing trees and hedgerows are shown to be removed to allow creation of a **Construction Working Area (CWA)**. Within this area the roots/stumps of felled tree and hedgerow vegetation should remain in-situ and not be grubbed out. Works within this area should otherwise follow the principals outlined within BS5837:2012, the following **Method Statement** to minimise the impact of Construction Access upon the the rootzones of the adjacent trees and hedgerow;

- Select site access route and construction plant that can safely access the **CWA** given the physical constraints imposed by the height of the existing tree canopies.
- For construction purposes, systems for the control and suppression of dust, hydrocarbons, cementitious and other phytotoxic elements should be employed to prevent damage to the adjacent trees and hedgerow.
- Do not store materials or construction plant within the CWA.
- Depth of any excavation work within the CWA to be generally minimised to reduce the potential to expose and/or damage shallow tree roots. Consideration should be given to the re-use of the existing foundations/sub-base of hard surfaced areas where possible.
- Provide ground protection to minimise excessive compaction from people/plant. This should include the use of temporary ground protection and selection of light, tracked plant over heavier, wheeled alternatives.

Any minor tree surgery proposed to facilitate demolition or construction access will be undertaken by an Arboricultural Association Approved Contractor with works compliant with BS3998:2010 Tree work - recommendations. Any tree surgery proposed will be subject to approval of the Local Planning Authority Tree Officer.

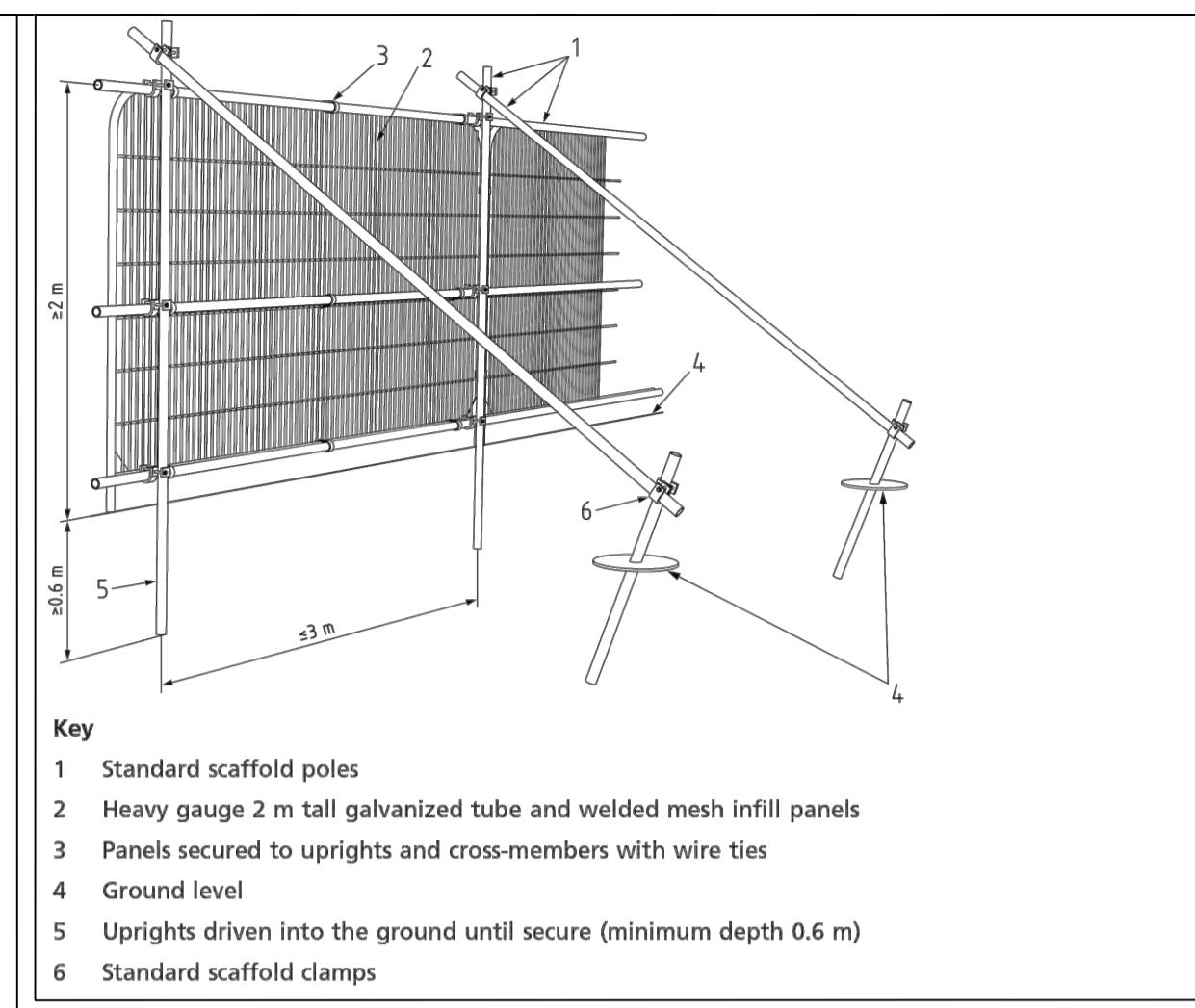

Fig 1: Default specification for protective barrier. Reproduced from BS5837:2012.

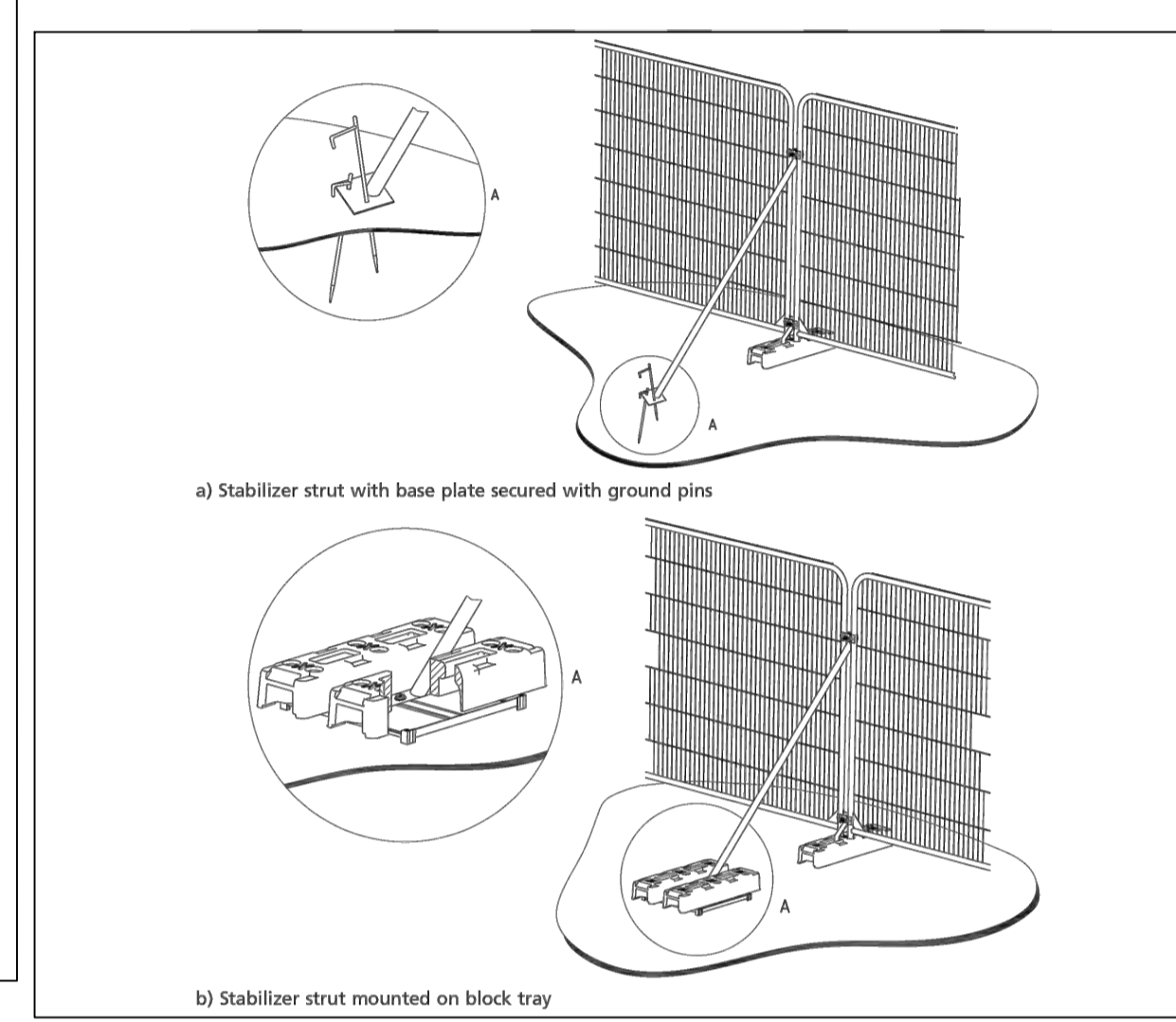

Fig 2: Examples of above-ground stabilizing systems. Reproduced from BS5837:2012.

	LTA 1 BOUNDARY
	LTA 2 BOUNDARY
	RODNEY HOUSE ROUNDABOUT HIGHWAYS WORKS BOUNDARY
	TEMPORARY EXCLUSION AMPHIBIAN FENCING FOR GREAT CRESTED NEWTS
	ONE WAY FENCING FOR GREAT CRESTED NEWTS
	TREES, GROUPS OR HEDGES TO BE RETAINED
	SCRUB & WOODY VEGETATION AS RECORDED BY TOPOGRAPHICAL SURVEY WITHIN LTA 1 TO BE RETAINED
	TREES, GROUPS OR HEDGES TO BE REMOVED
	SCRUB & WOODY VEGETATION AS RECORDED BY TOPOGRAPHICAL SURVEY WITHIN LTA 1 TO BE REMOVED
	ROOT PROTECTION AREAS (RPA)
	PROTECTION FENCING Refer to detail (Fig 1 and Fig 2)
	CONSTRUCTION WORKING AREA Refer to Landscape Specification for details.
	INDICATIVE EXTENT OF GROUPED FEATURE

Rev	Date	Description	By
D	11:03:16	UPDATED TO SUIT HIGHWAYS LAYOUT AMENDMENTS	RSM
C	23:02:16	UPDATED TO SUIT PROPOSED ROUNDABOUT WORKS	DD
B	05:01:16	HIGHWAYS BOUNDARY SHOWN. UPDATED TO TENDER STATUS.	LB
A	22:12:15	UPDATED TO SUIT PROPOSED HIGHWAYS WORKS	LB

Amendments

Project **GRAVEN HILL, BICESTER**

Title **LTA 1
TREE AND HABITAT PROTECTION PLAN
(RODNEY HOUSE ROUNDABOUT)
SHEET 1 OF 12**

Client **Graven Hill Village Development Company Limited**

Merchants House Wapping Road Bristol BS1 4RW
 1 0117 937 8200
 mail@watermangroup.com www.watermangroup.com

Drawing Status				
TENDER				
Designed by	DD	Checked by	TA	Project No
Drawn by	DD	Date	Nov 2015	WIB13983
Scales @ A1 work to figured dimensions only	1:500 @A1		Work Order No	107
Publisher	Zone	Category	Number	Revision
WIB	AA	74	503	D

REFER TO DRAWING No. WIB13983-107-AA-74-504

REFER TO DRAWING No. WIB13983-107-AA-74-505

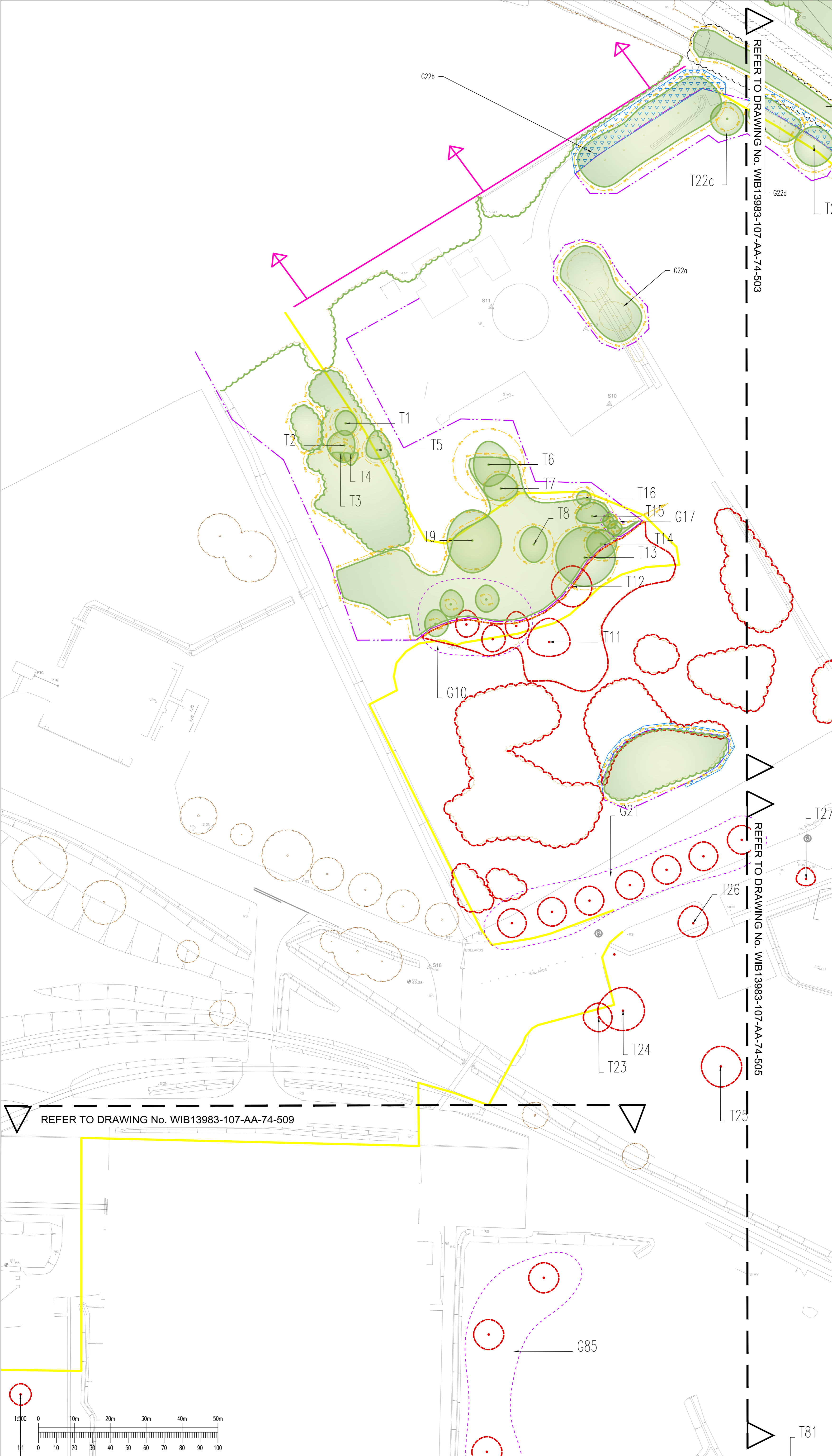

- LTA 1 BOUNDARY
- LTA 2 BOUNDARY
- TEMPORARY EXCLUSION AMPHIBIAN FENCING FOR GREAT CRESTED NEWTS
- ONE WAY FENCING FOR GREAT CRESTED NEWTS
- TREES, GROUPS OR HEDGES TO BE RETAINED
- TREES, GROUPS OR HEDGES TO BE REMOVED
- ROOT PROTECTION AREAS (RPA)
- PROTECTION FENCING
Refer to detail (Fig 1 and Fig 2) on Drawing No: WIB13983-107-AA-74-503
- CONSTRUCTION WORKING AREA
Refer to Landscape Specification for details.
- INDICATIVE EXTENT OF GROUPED FEATURE

Note:

Refer to Waterman Drawing No. WIC15119-118-AA-77-002 to 004 for baseline survey data.

All works to be carried out in accordance with the principles of BS5837:2012 when in proximity to retained trees and hedgerows.

Tree protection fencing to be erected in accordance with the enclosed details and maintained as a Construction Exclusion Zone for the duration of all construction works.

Refer to notes on Drawing No: WIB13983-107-AA-74-503 for further detail.

Rev	Date	Description	By
A	11.03.16	UPDATED TO SUIT HIGHWAYS LAYOUT AMENDMENTS	RSM

Amendments

Project GRAVEN HILL, BICESTER

Title LTA 1
TREE AND HABITAT PROTECTION PLAN
(Sheet 2 of 12)

Client Graven Hill Village Development Company

Merchants House Wapping Road Bristol BS1 4RW
t 0117 937 8200
mail@watermangroup.com www.watermangroup.com

Drawing Status TENDER

Designed by	RA	Checked by	TA	Project No	WIB13983
Drawn by	DD	Date	February 2016	Work Order No	107
Scales @ A1		work to figured dimensions only 1:500 @A1			
Publisher	Zone	Category	Number	Revision	
WIB	AA	74	504		

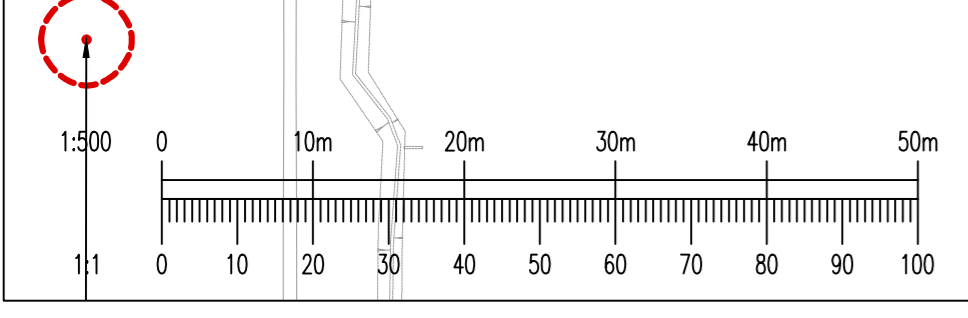

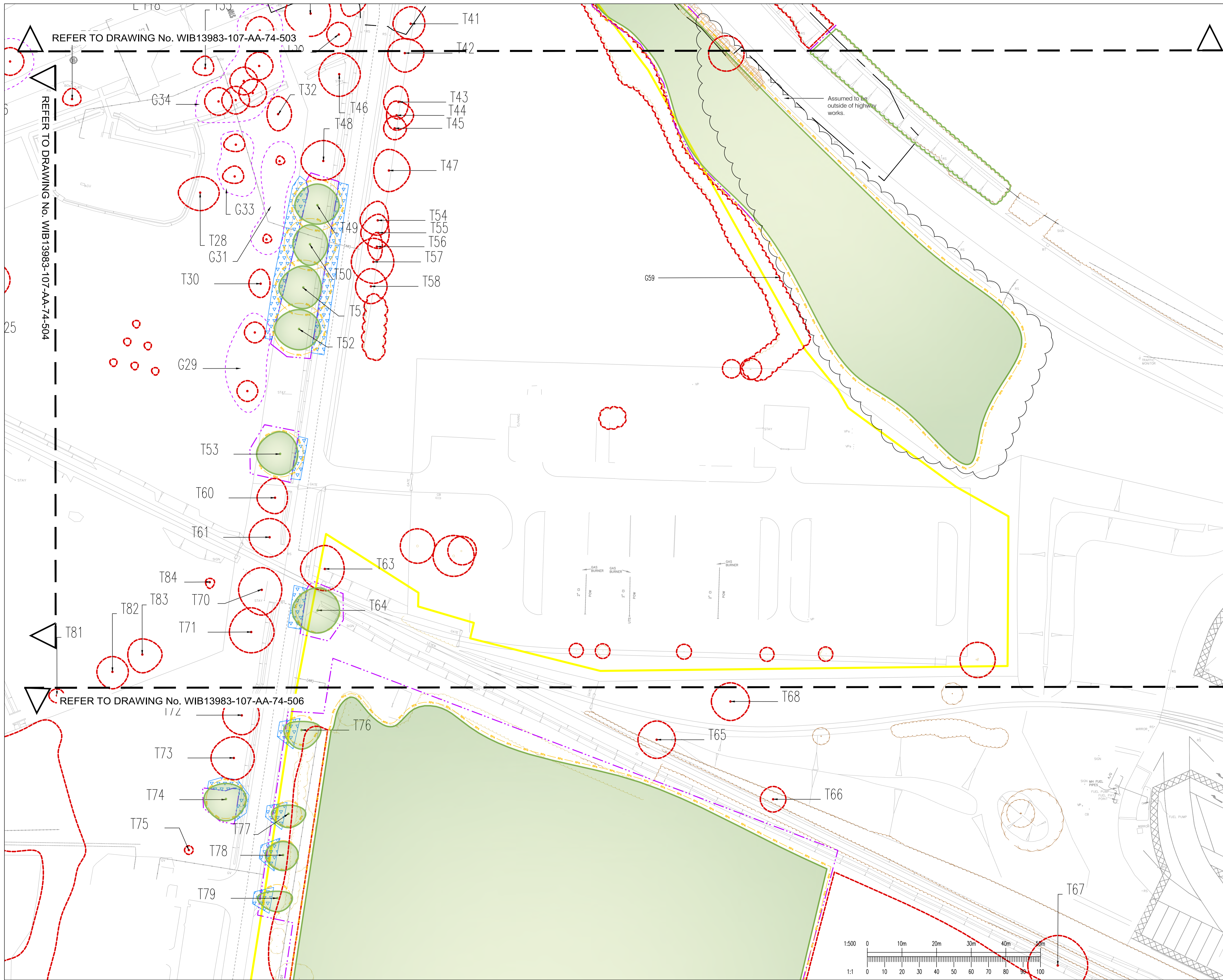









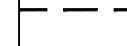



REFER TO DRAWING No. WIB13983-107-AA-74-503

REFER TO DRAWING No. WIB13983-107-AA-74-504

REFER TO DRAWING No. WIB13983-107-AA-74-506

-  LTA 1 BOUNDARY
-  LTA 2 BOUNDARY
-  RODNEY HOUSE ROUNDABOUT HIGHWAYS WORKS BOUNDARY
-  TEMPORARY EXCLUSION AMPHIBIAN FENCING FOR GREAT CRESTED NEWTS
-  ONE WAY FENCING FOR GREAT CRESTED NEWTS
-  TREES, GROUPS OR HEDGES TO BE RETAINED
-  SCRUB & WOODY VEGETATION AS RECORDED BY TOPOGRAPHICAL SURVEY WITHIN LTA 1 TO BE RETAINED
-  TREES, GROUPS OR HEDGES TO BE REMOVED
-  SCRUB & WOODY VEGETATION AS RECORDED BY TOPOGRAPHICAL SURVEY WITHIN LTA 1 TO BE REMOVED
-  ROOT PROTECTION AREAS (RPA)
-  PROTECTION FENCING Refer to detail (Fig 1 and Fig 2) on Drawing No: WIB13983-107-AA-74-503
-  CONSTRUCTION WORKING AREA Refer to Landscape Specification for details.
-  INDICATIVE EXTENT OF GROUPED FEATURE

Note:
 Refer to Waterman Drawing No. WIC15119-118-AA-77-002 to 004 for baseline survey data.
 All works to be carried out in accordance with the principles of BS5837:2012 when in proximity to retained trees and hedgerows.
 Tree protection fencing to be erected in accordance with the enclosed details and maintained as a Construction Exclusion Zone for the duration of all construction works.
 Refer to notes on Drawing No. WIB13983-107-AA-74-503 for further detail.

Rev	Date	Description	By
A	11.03.16	UPDATED TO SUIT HIGHWAYS LAYOUT AMENDMENTS	RSM

Amendments
GRAVEN HILL, BICESTER
 Title
LTA 1
TREE AND HABITAT PROTECTION PLAN
 (Sheet 3 of 12)

Client

 Graven Hill Village Development Company

 Merchants House Wapping Road Bristol BS1 4RW
 1 0117 937 8200
 mail@watermangroup.com www.watermangroup.com

Drawing Status				
TENDER				
Designed by	RA	Checked by	TA	Project No
Drawn by	DD	Date	February 2016	WIB13983
Scalcs @ A1	work to figured dimensions only		1:500 @A1	Work Order No
				107
Publisher	Zone	Category	Number	Revision
WIB	AA	74	505	A

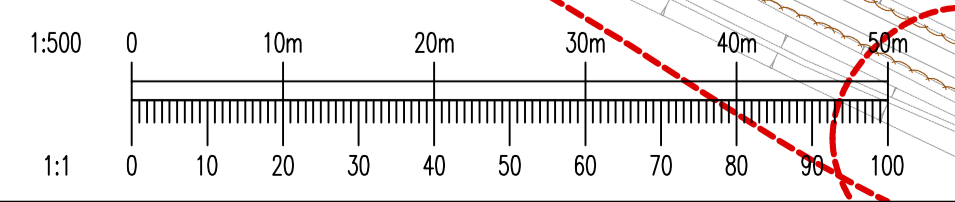



Legend

- LTA 1 BOUNDARY
- LTA 2 BOUNDARY
- TEMPORARY EXCLUSION AMPHIBIAN FENCING FOR GREAT CRESTED NEWTS
- ONE WAY FENCING FOR GREAT CRESTED NEWTS
- TREES, GROUPS OR HEDGES TO BE RETAINED
- SCRUB & WOODY VEGETATION AS RECORDED BY TOPOGRAPHICAL SURVEY WITHIN LTA 1 TO BE RETAINED
- TREES, GROUPS OR HEDGES TO BE REMOVED
- SCRUB & WOODY VEGETATION AS RECORDED BY TOPOGRAPHICAL SURVEY WITHIN LTA 1 TO BE REMOVED
- ROOT PROTECTION AREAS (RPA)
- PROTECTION FENCING
Refer to detail (Fig 1 and Fig 2) on Drawing No: WIB13983-107-AA-74-503
- CONSTRUCTION WORKING AREA
Refer to Landscape Specification for details.
- INDICATIVE EXTENT OF GROUPED FEATURE

Note:
 Refer to Waterman Drawing No. WIC15119-118-AA-77-002 to 004 for baseline survey data.
 All works to be carried out in accordance with the principles of BS5837:2012 when in proximity to retained trees and hedgerows.
 Tree protection fencing to be erected in accordance with the enclosed details and maintained as a Construction Exclusion Zone for the duration of all construction works.
 Refer to notes on Drawing No: WIB13983-107-AA-74-503 for further detail.

Rev	Date	Description	By
A	11.03.16	UPDATED TO SUIT HIGHWAYS LAYOUT AMENDMENTS	RSM

Amendments

Project
GRAVEN HILL, BICESTER

Title
LTA 1
TREE AND HABITAT PROTECTION PLAN
(Sheet 4 of 12)

Client



Graven Hill Village Development Company



Merchants House Wapping Road Bristol BS1 4RW
 1 0117 937 8200
 mail@watermangroup.com www.watermangroup.com

Drawing Status

TENDER		Project No	WIB13983
Designed by	RA	Checked by	TA
Drawn by	DD	Date	February 2016
Scale	1:500 @A1	Work Order No	107
Scalable	work to figured dimensions only	Number	506
Revision		Zone	AA
		Category	74
		Number	506
		Revision	A

REFER TO DRAWING No. WIB13983-107-AA-74-503

REFER TO DRAWING No. WIB13983-107-AA-74-509

Cut back overhanging branches to allow for the construction of parking spaces.

Woodland (W80) to be thinned out by 50% removing suppressed and weaker trees.

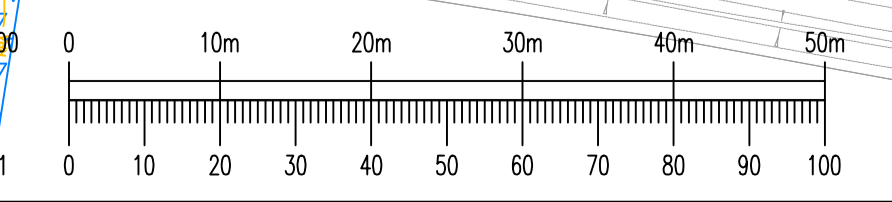

REFER TO DRAWING No. WIB13983-107-AA-74-513

REFER TO DRAWING No. WIB13983-107-AA-74-510

REFER TO DRAWING No. WIB13983-107-AA-74-507

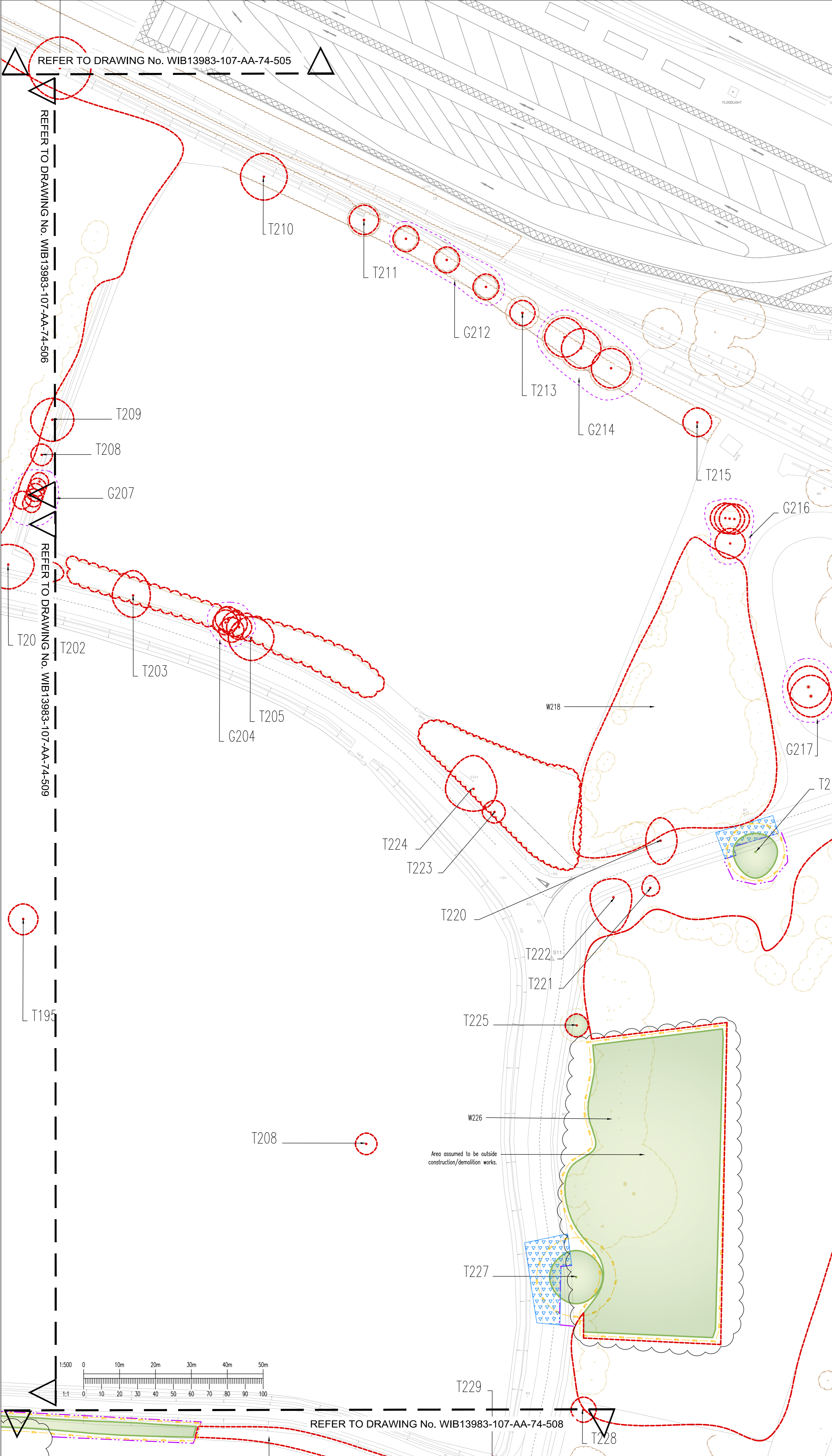

- LTA 1 BOUNDARY
- LTA 2 BOUNDARY
- TEMPORARY EXCLUSION AMPHIBIAN FENCING FOR GREAT CRESTED NEWTS
- ONE WAY FENCING FOR GREAT CRESTED NEWTS
- TREES, GROUPS OR HEDGES TO BE RETAINED
- SCRUB & WOODY VEGETATION AS RECORDED BY TOPOGRAPHICAL SURVEY WITHIN LTA 1 TO BE RETAINED
- TREES, GROUPS OR HEDGES TO BE REMOVED
- SCRUB & WOODY VEGETATION AS RECORDED BY TOPOGRAPHICAL SURVEY WITHIN LTA 1 TO BE REMOVED
- ROOT PROTECTION AREAS (RPA)
- PROTECTION FENCING Refer to detail (Fig 1 and Fig 2) on Drawing No: WIB13983-107-AA-74-503
- CONSTRUCTION WORKING AREA Refer to Landscape Specification for details.
- INDICATIVE EXTENT OF GROUPED FEATURE

Note:
 Refer to Waterman Drawing No. WIC15119-118-AA-77-002 to 004 for baseline survey data.
 All works to be carried out in accordance with the principles of BS5837:2012 when in proximity to retained trees and hedgerows.
 Tree protection fencing to be erected in accordance with the enclosed details and maintained as a Construction Exclusion Zone for the duration of all construction works.
 Refer to notes on Drawing No: WIB13983-107-AA-74-503 for further detail.

Rev	Date	Description	By
A	11.03.16	UPDATED TO SUIT HIGHWAYS LAYOUT AMENDMENTS	RSM

Amendments
Project GRAVEN HILL, BICESTER
Title LTA 1 TREE AND HABITAT PROTECTION PLAN (Sheet 5 of 12)
Client Graven Hill Village Development Company

Merchants House Wapping Road Bristol BS1 4RW
 t 0117 937 8200
 mail@watermangroup.com www.watermangroup.com
Drawing Status TENDER

Designed by	RA	Checked by	TA	Project No.	WIB13983
Drawn by	DD	Date	February 2016	Work Order No.	107
Scales @ A1		work to figured dimensions only 1:500 @A1			
Publisher	Zone	Category	Number	Revision	
WIB	AA	74	507	A	

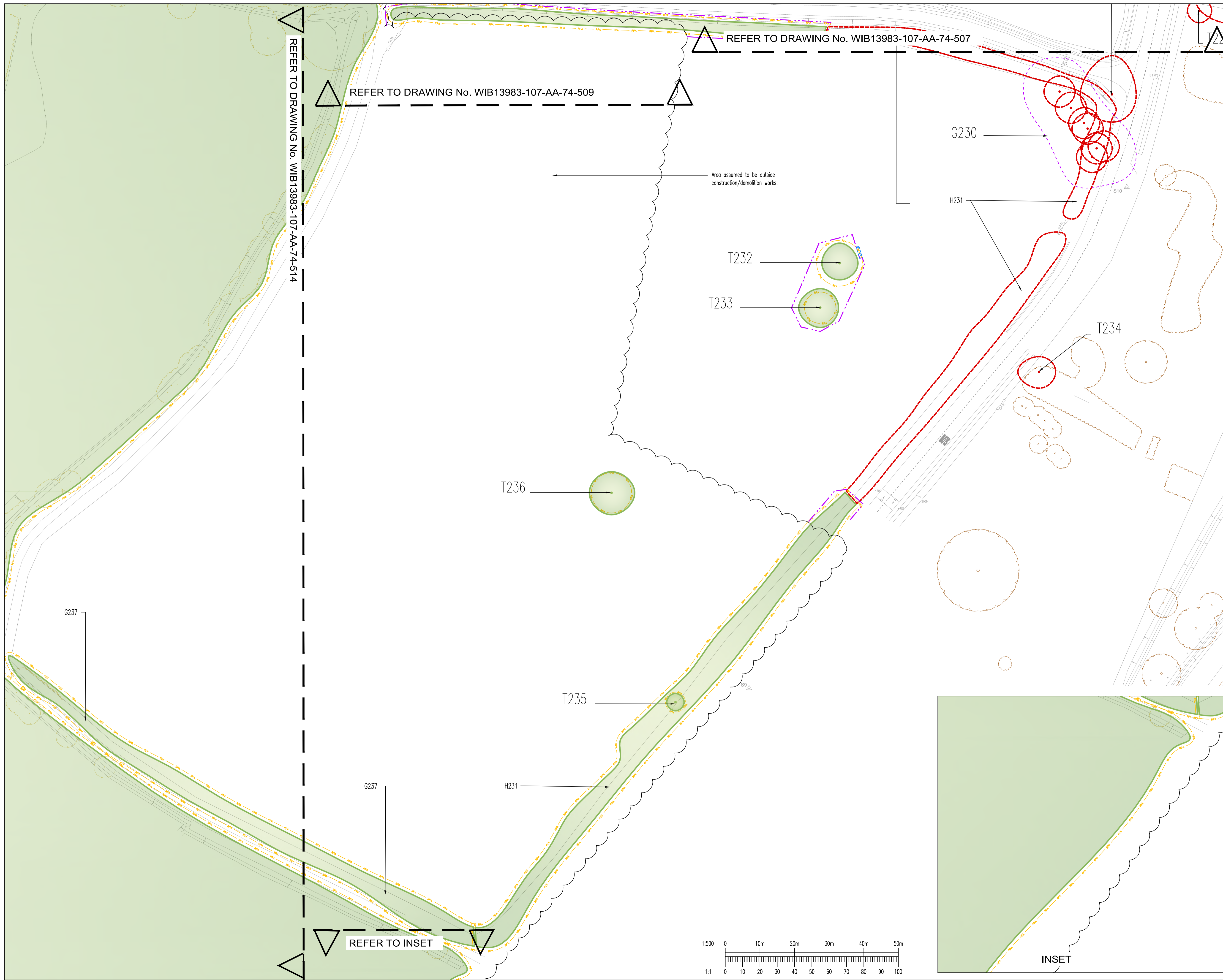

- LTA 1 BOUNDARY
- LTA 2 BOUNDARY
- TEMPORARY EXCLUSION AMPHIBIAN FENCING FOR GREAT CRESTED NEWTS
- ONE WAY FENCING FOR GREAT CRESTED NEWTS
- TREES, GROUPS OR HEDGES TO BE RETAINED
- SCRUB & WOODY VEGETATION AS RECORDED BY TOPOGRAPHICAL SURVEY WITHIN LTA 1 TO BE RETAINED
- TREES, GROUPS OR HEDGES TO BE REMOVED
- SCRUB & WOODY VEGETATION AS RECORDED BY TOPOGRAPHICAL SURVEY WITHIN LTA 1 TO BE REMOVED
- ROOT PROTECTION AREAS (RPA)
- PROTECTION FENCING
Refer to detail (Fig 1 and Fig 2) on Drawing No: WIB13983-107-AA-74-503
- CONSTRUCTION WORKING AREA
Refer to Landscape Specification for details.
- INDICATIVE EXTENT OF GROUPED FEATURE

Note:
 Refer to Waterman Drawing No. WIC15119-118-AA-77-002 to 004 for baseline survey data.
 All works to be carried out in accordance with the principles of BS5837:2012 when in proximity to retained trees and hedgerows.
 Tree protection fencing to be erected in accordance with the enclosed details and maintained as a Construction Exclusion Zone for the duration of all construction works.
 Refer to notes on Drawing No: WIB13983-107-AA-74-503 for further detail.

Rev	Date	Description	By
A	11.03.16	UPDATED TO SUIT HIGHWAYS LAYOUT AMENDMENTS	RSM

Project: **GRAVEN HILL, BICESTER**
 Title: **LTA 1 TREE AND HABITAT PROTECTION PLAN (Sheet 6 of 12)**



Drawing Status: TENDER				
Designed by: RA	Checked by: TA	Project No: WIB13983		
Drawn by: DD	Date: February 2016	Work Order No: 107		
Scales @ A1 work to figured dimensions only: 1:500 @A1				
Publisher: WIB	Zone: AA	Category: 74	Number: 508	Revision: A

