

This drawing should not be scaled. Dimensions to be verified on site. Any discrepancies should be referred to the Engineer prior to work being put in hand.  
 This drawing is the property of Waterman Infrastructure & Environment Limited, and the drawing is issued on the condition that it is not copied, reproduced, retained or disclosed to any unauthorised person, either wholly or in part without the consent in writing of Waterman Infrastructure & Environment Limited.  
 Pedkrets Way, Celia Street, London SE1 9QG. T 020 7928 7888. F 03333 444 501

**GENERAL NOTES**

1. THIS DRAWING IS TO BE READ IN CONJUNCTION WITH ALL ENGINEERS, ARCHITECTS OR OTHER RELEVANT DRAWINGS AND SPECIFICATIONS.
2. ALL DIMENSIONS AND LEVELS ARE TO BE CHECKED ON SITE BY THE CONTRACTOR PRIOR TO PREPARING ANY WORKING DRAWINGS OR COMMENCING ON SITE.
3. THE CONTRACTOR MUST ENSURE AND WILL BE HELD RESPONSIBLE FOR THE OVERALL STABILITY OF THE BUILDING/STRUCTURE/EXCAVATION AT ALL STAGES OF THE WORK.
4. ALL WORK BY THE CONTRACTOR MUST BE CARRIED OUT IN SUCH A WAY THAT ALL REQUIREMENTS UNDER THE HEALTH AND SAFETY AT WORK ACT ARE SATISFIED.
5. ALL WORK IS TO BE CARRIED OUT IN COMPLIANCE WITH THE REQUIREMENTS OF THE RELEVANT STATUTORY AUTHORITIES AND REGULATIONS.

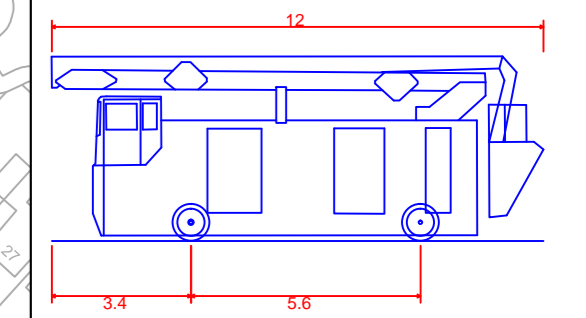

Aerial Platform/ Turntable Ladder/ Special Appliance  
 Overall Length 12.00m  
 Overall Width 2.50m  
 Overall Body Height 4.50m  
 Min Body Ground Clearance 0.150m  
 Track Width 2.50m  
 Lock to Lock Time 4.00s  
 Kerb to Kerb Turning Radius 13.75m

**KEY**



PROPOSED GRANITE SETTS  
 OVERRUN STRIP



Proposed Overrun Area  
 150mm x 150mm granite setts  
 laid on 25mm sand bedding on  
 150mm thick Class 2 concrete  
 foundation laid on 150mm thick  
 type 1 sub base and 600mm  
 thick type #2 capping

Proposed Overrun Area  
 150mm x 150mm granite setts  
 laid on 25mm sand bedding on  
 150mm thick Class 2 concrete  
 foundation laid on 150mm thick  
 type 1 sub base and 600mm  
 thick type #2 capping

SCALE 1:500

SCALE 1:500

SCALE 1:500

Rev	Date	Description	By
002	20.01.16	GRANITE SETTS OVERRUN AREA ADDED	AG
001	06.10.15	ISSUED FOR APPROVAL	AJ
003	06.10.15	TRACKING AMENDED TO SET UPDATED LAYOUT	AG
002	05.10.15	CONTRACTOR SITE LAYOUT UPDATED	AG
001	18.08.15	ISSUED AS PRELIMINARY	AG

**Project**  
 GRAVEN HILL, BICESTER

**Title**  
 FIRE TENDER  
 SWEEP PATH ANALYSIS

**Client**  
 GRAVEN HILL VILLAGE DEVELOPMENT COMPANY LIMITED



Approval				
Designed by	Checked by	Date	Project No.	Revision
AG	AJ	18.08.15	CIV 15119	
Scale @ A0	Scale @ A3	Scale @ A4	Scale @ A5	Scale @ A6
1:1000	1:1000	1:1000	1:1000	1:1000
Author	Zone	Category	Number	Revision
C	SA	90	0811	C02

