

This drawing should not be scaled. Dimensions to be verified on site. Any discrepancies should be referred to the Engineer prior to work being put in hand.  
 This drawing is the property of Waterman Infrastructure & Environment Limited, and the drawing is issued on the condition that it is not copied, reproduced, retained or disclosed to any unauthorised person, either wholly or in part without the consent in writing of Waterman Infrastructure & Environment Limited.  
 PedKovits Wharf, Celia Street, London SE1 9QG. T 020 7928 7888. F 03333 444 501

**GENERAL NOTES**

1. THIS DRAWING IS TO BE READ IN CONJUNCTION WITH ALL ENGINEERS, ARCHITECTS OR OTHER RELEVANT DRAWINGS AND SPECIFICATIONS.
2. ALL DIMENSIONS AND LEVELS ARE TO BE CHECKED ON SITE BY THE CONTRACTOR PRIOR TO PREPARING ANY WORKING DRAWINGS OR COMMENCING ON SITE.
3. THE CONTRACTOR MUST ENSURE AND WILL BE HELD RESPONSIBLE FOR THE OVERALL STABILITY OF THE BUILDING/STRUCTURE/EXCAVATION AT ALL STAGES OF THE WORK.
4. ALL WORK BY THE CONTRACTOR MUST BE CARRIED OUT IN SUCH A WAY THAT ALL REQUIREMENTS UNDER THE HEALTH AND SAFETY AT WORK ACT ARE SATISFIED.
5. ALL WORK IS TO BE CARRIED OUT IN COMPLIANCE WITH THE REQUIREMENTS OF THE RELEVANT STATUTORY AUTHORITIES AND REGULATIONS.

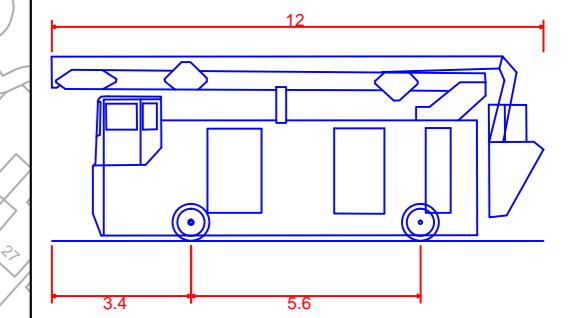

**Aerial Platform/ Turntable Ladder/ Special Appliance**  
 Overall Length 12.000m  
 Overall Width 2.550m  
 Overall Body Height 4.500m  
 Min Body Ground Clearance 0.150m  
 Track Width 2.550m  
 Lock to Lock Time 4.00s  
 Kerb to Kerb Turning Radius 13.750m

**KEY**

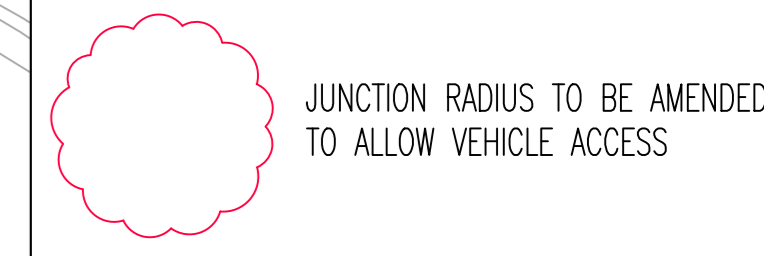

| Rev | Date     | Description                             | By |
|-----|----------|---|----|
| C01 | 06/10/15 | ISSUED FOR APPROVAL                     | AJ |
| A03 | 08/10/15 | TRACKING AMENDED TO SITE UPDATED LAYOUT | AG |
| A02 | 05/10/15 | CONTRACTOR SITE LAYOUT UPDATED          | AG |
| A01 | 18/08/15 | ISSUED AS PRELIMINARY                   | AG |

**Project**  
GRAVEN HILL, BICESTER

**Title**  
FIRE TENDER  
SWEEP PATH ANALYSIS

**Client**  
GRAVEN HILL VILLAGE DEVELOPMENT COMPANY LIMITED



| FOR APPROVAL |              |              |              |              |
|--------------|--------------|--------------|--------------|--------------|
| Designed by  | Checked by   | Date         | Project No   | Revision     |
| AG           | AJ           | 18.08.15     | CIV 15119    |              |
| Scale: If A0 | Scale: If A0 | Scale: If A0 | Scale: If A0 | Scale: If A0 |
| 1:1000       | 1:1000       | 1:1000       | 1:1000       | 1:1000       |
| Author       | Zone         | Category     | Number       | Revision     |
| C            | SA           | 90           | 0811         | C01          |

