

Priority over oncoming vehicles

DIAG 811

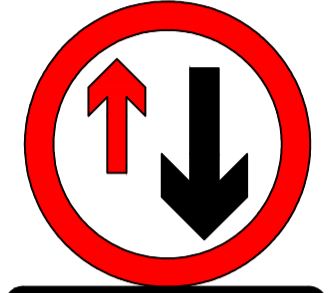

Give way to oncoming vehicles

DIAG 615

KEY

— CONCRETE JERSEY BARRIER



- - - EXISTING BRIDLEWAY FENCE

— INDICATIVE PROPOSED BRIDLEWAY FENCE

■ AREA TO BE KEPT CLEAR FOR VISIBILITY PURPOSES

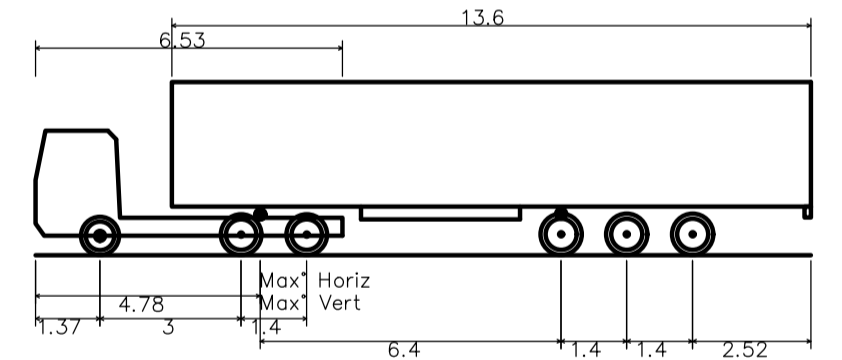

Articulated Vehicle (16.5m)	16.500m
Overall Length	16.500m
Overall Width	2.550m
Overall Body Height	3.681m
Min Body Ground Clearance	0.411m
Max Track Width	2.500m
Lock to lock time	6.00s
Kerb to Kerb Turning Radius	6.530m

A	CHANGES TO BARRIER LENGTH AND COST	04/06/18	JC	PR	-
Mark	Revision	Date	Drawn	Chkd	Appd

SCALING NOTE: Do not scale from this drawing. If in doubt, ask.
UTILITIES NOTE: The position of any existing public or private sewers, utility services, plant or apparatus shown on this drawing is believed to be correct, but no warranty to this is expressed or implied. Other such plant or apparatus may also be present but not shown. The Contractor is therefore advised to undertake their own investigation where the presence of any existing sewers, services, plant or apparatus may affect their operations.

Drawing Issue Status: **FINAL**

**HEYFORD PARK
WESTERN AIRFIELD
ROAD LAYOUT PREFERRED OPTION**

Client
**DORCHESTER
GROUP**



Date of 1st Issue	Designed	Drawn
24/05/18	JC	JC
A2 Scale	Checked	Approved
1:1250	DH	-

Offices throughout the UK and Europe
www.peterbrett.com
© Peter Brett Associates LLP
READING
Tel: 01189 500 761

Drawing Number	Revision
39304/5501/SK47	A