

Gg Verge Detail - Green Roof
Type 8 - Bekstone

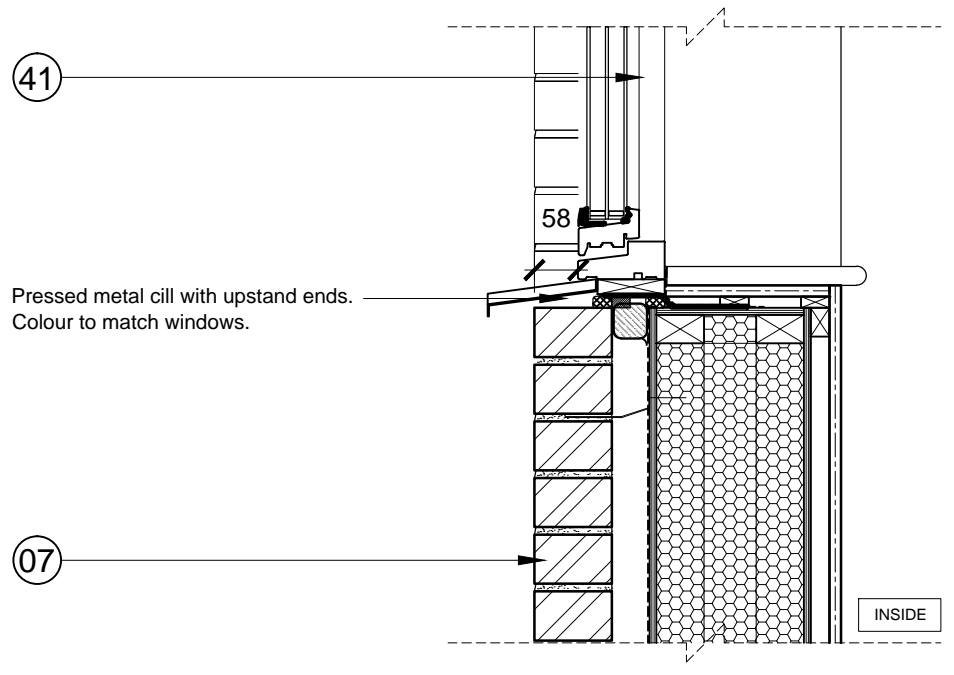

Kk Window Detail - Cill
Type 7 - Brickwork

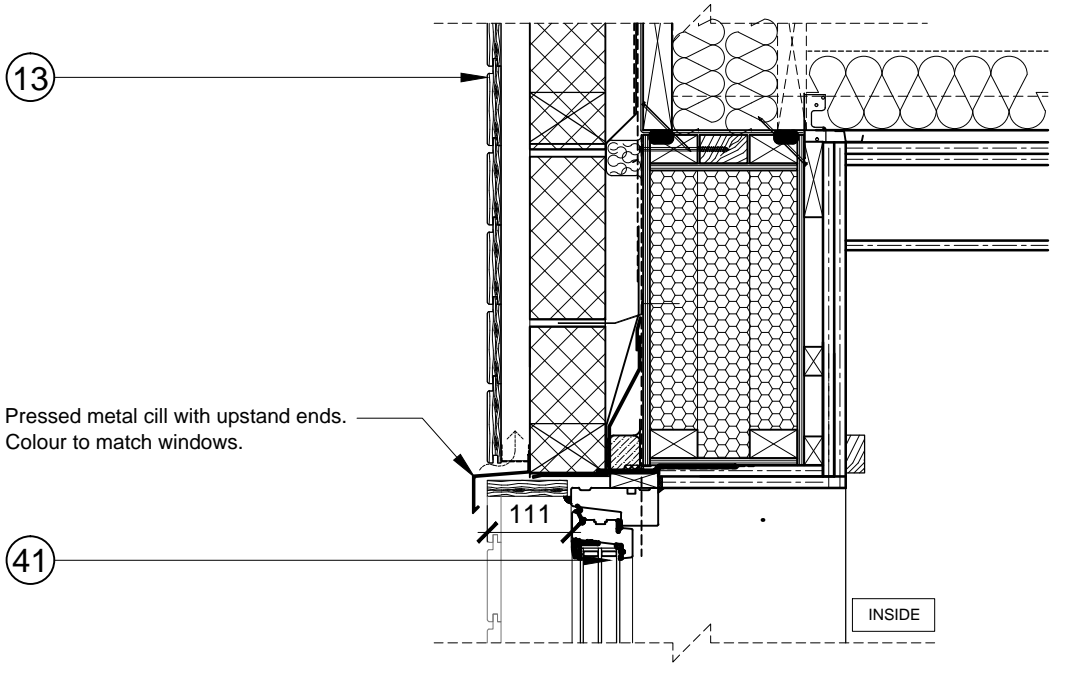

Oo Window Head Detail
Type 7 - Horizontal Timber Cladding

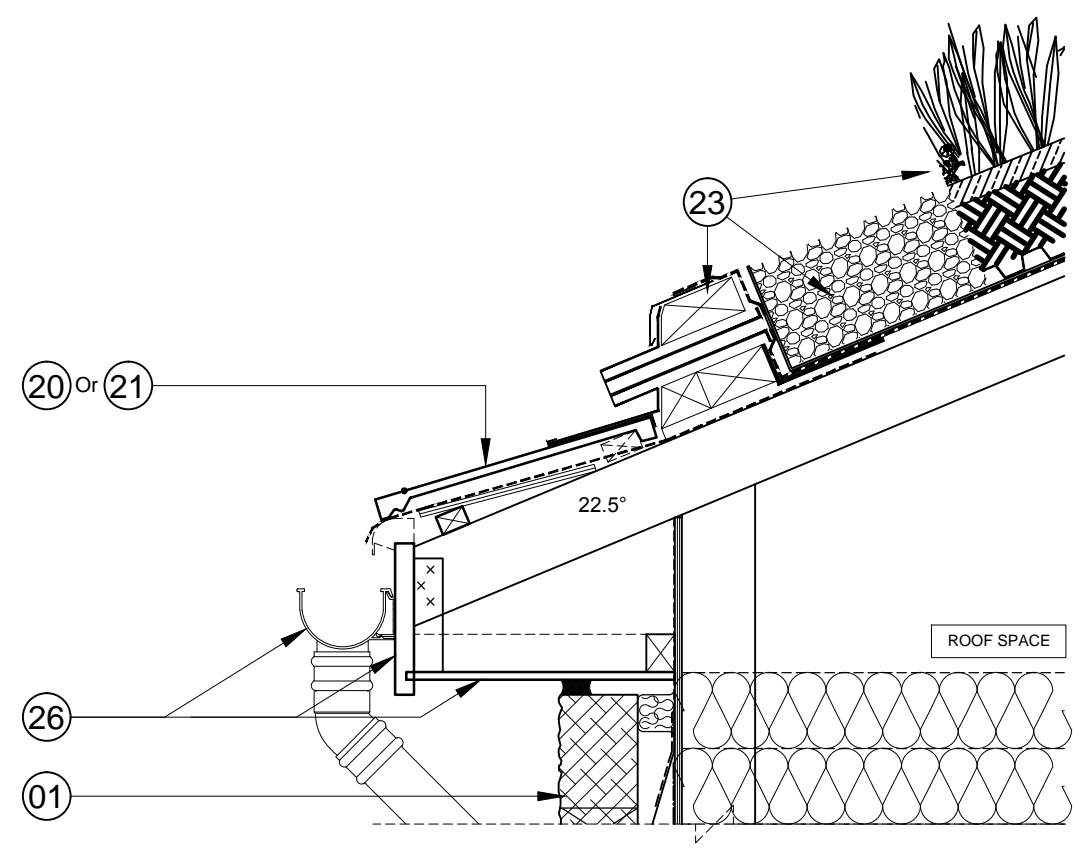

Hh Eaves Detail - Green Roof
Type 8 - Bekstone

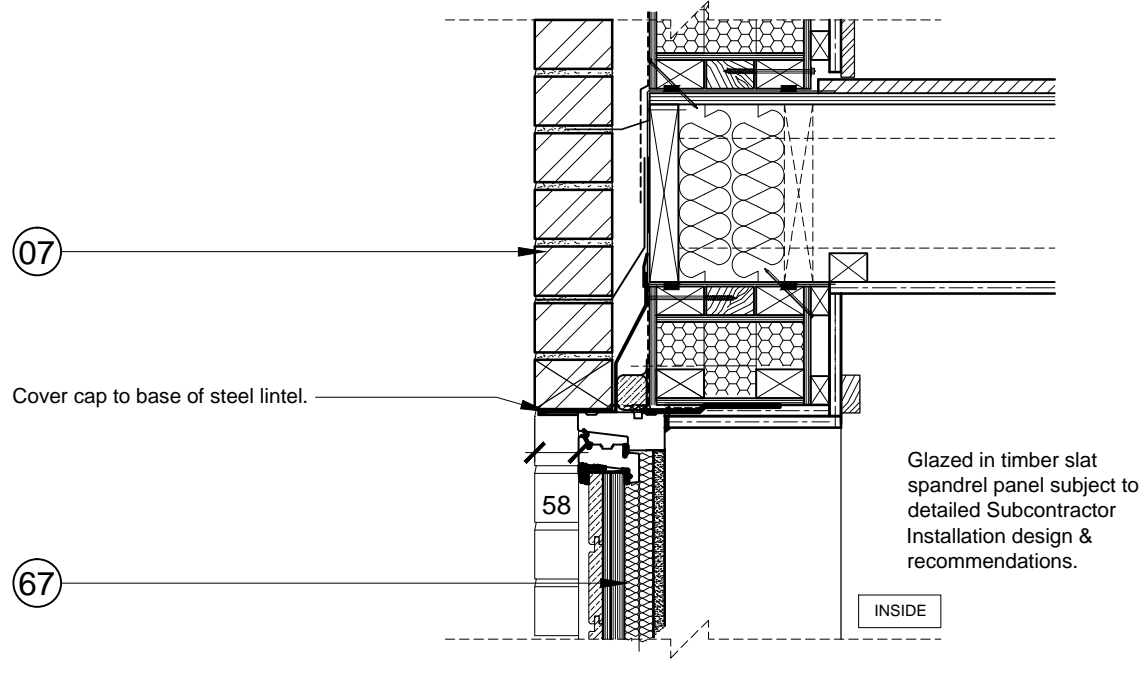

Ll Window Head Detail - Timber Spandrel
Type 7 - Brickwork

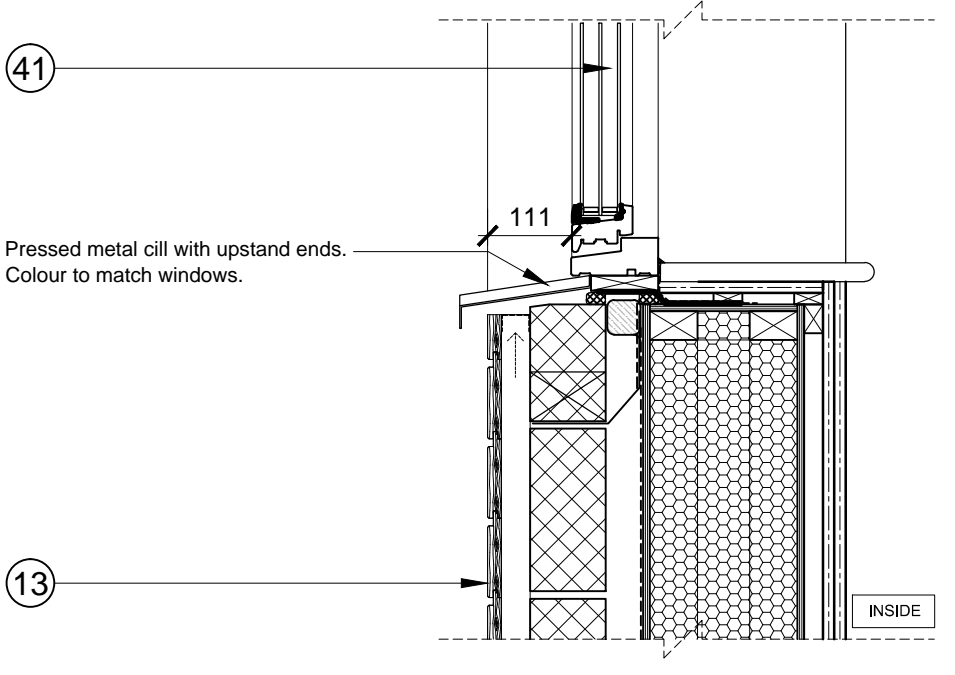

Pp Window Detail - Cill
Type 7 - Horizontal Timber Cladding

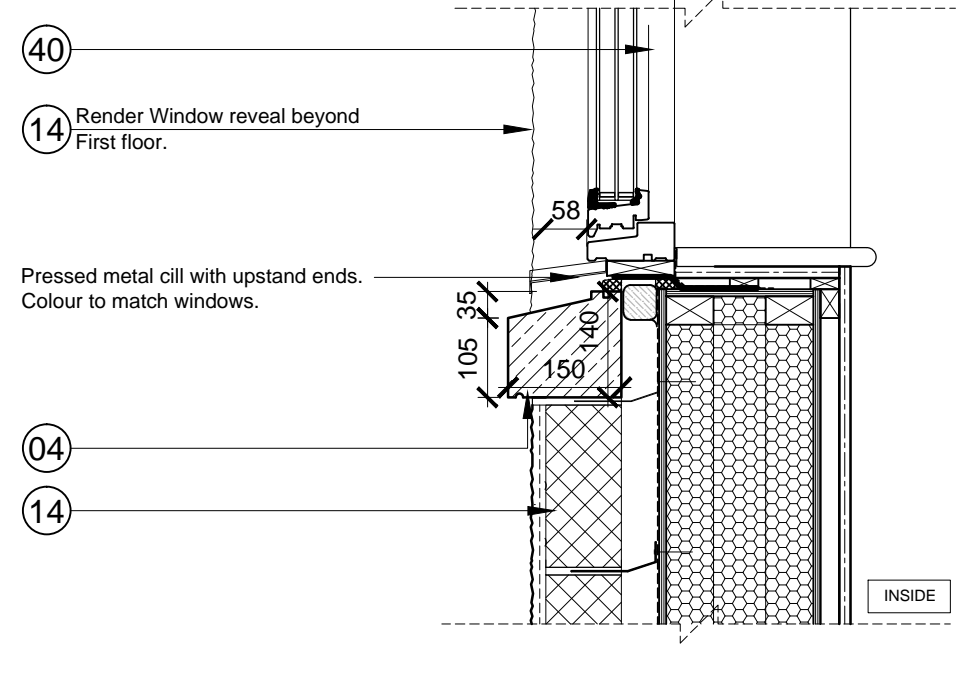

Ii Window Detail - Stone Cill
Type 1 - Render

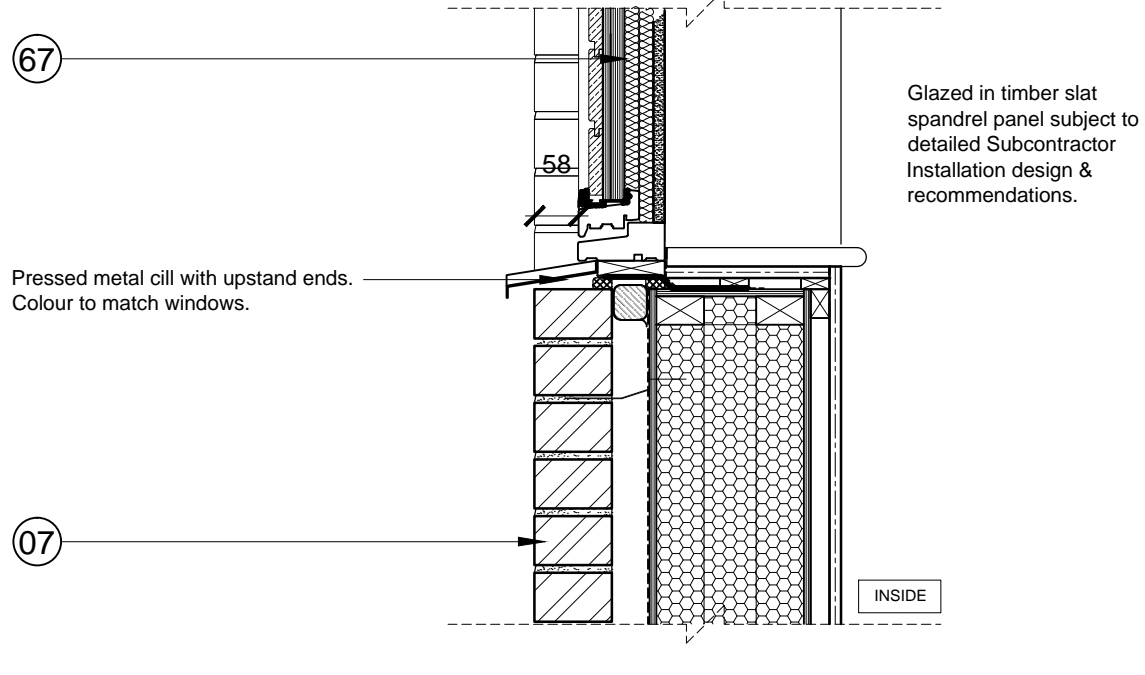

Mm Window Cill Detail - Timber Spandrel
Type 7 - Brickwork

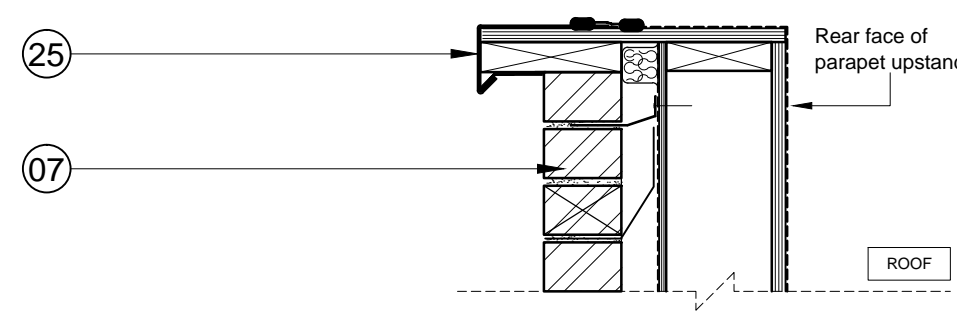

Jj Roof Parapet Detail
Type 7 - Brickwork

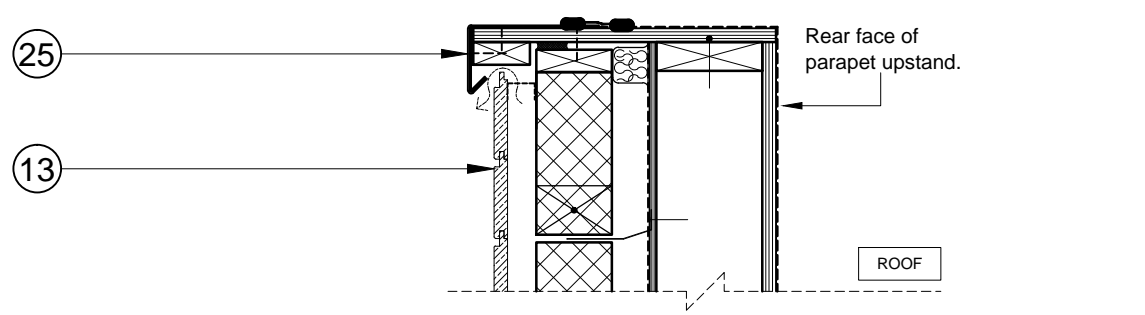

Jj Roof Parapet Detail
Type 7 - Horizontal Timber Cladding

The contractor is responsible for checking dimensions, tolerances and references. Any discrepancy to be verified with the Architect before proceeding with the works. Where an item is covered by drawings to different scales the larger scale drawing is to be worked to.
Do not scale drawing. Figured dimensions to be worked to in all cases.
CDM REGULATIONS 2015. All current drawings and specifications for the project must be read in conjunction with the Designer's Hazard and Environment Assessment Record
All intellectual property rights reserved.

- KEY**
- 01 Coursed stonework [Bekstone 'Natural light weathered' (tumbled); laid in random course heights - no jumpers]
 - 02 Reconstituted stone corbel unit [colour: Oolite]
 - 03 Projecting reconstituted stone string course [colour: Oolite] to divide Bekstone below from render above.
 - 04 Reconstituted stone [colour: Oolite] heads with drip detail and stooled cill
 - 07 Face brickwork - Ibstock 'Capital Multi Stock'; laid stretcher bond with natural colour bucket handle mortar joints.
 - 09 Brickwork window heads & cant brick cills; type / colour: to match face brickwork
 - 10 Brickwork corbel; type / colour: to match face brickwork
 - 11 Clipped verge detail. 2No. courses face brickwork laid stretcher bond with natural colour bucket handle mortar joints; brick type / colour: Ibstock 'Capital Multi Stock'.
 - 13 Horizontal timber cladding [Thermowood; with natural untreated finish]
 - 14 Through colour render; colour: Ivory (by K Rend or similar)
 - 16 Reconstituted stone cill [colour: Oolite]
 - 17 Vertical timber cladding [Thermowood; with natural untreated finish]
 - 20 Marley 'Rivendale' composite slate and ridge tile
 - 21 Bradstone Cotswold roof tile and ridge tile
 - 23 Roof designated for meadow grass [Bauder Green Roof or similar]
 - 25 PPC aluminium coping; colour: Grey (RAL 7015)
 - 26 UPVC gutters & down pipes; colour: black. Fascia & soffit board; colour: White (Types 1&8); Grey - RAL 7015 (Type 3 & E)
 - 27 Clipped verge detail
 - 40 High performance triple glazed timber window (Rational Aura or similar) design to match house type; colour: White
 - 41 High performance triple glazed timber window (Rational Aura or similar) design to match house type; colour: Grey (RAL 7015)
 - 67 Spandrel Panel: Horizontal timber cladding [Thermowood; with natural untreated finish]
 - 80 Proprietary dry fix roof verge system shown indicatively. Subject to roof tile Supplier/Manufacturer installation details & recommendations.

General Notes:

- * Key text above based on S96a Elevation Dwg series: AA2699(2)-2100 to 2126, with supplementary info added for products.
- * Refer to S96a Elevations for any colour identification where noted.
- * Timber Roof / Wall / Floor Panels / Linings + internal finishes ETC are all indicative & subject to detailed design.
- * Any dimensions shown indicate intended design; Subject to subcontractor/supplier installation design & recommendations.
- * To be read in conjunction with external materials schedule doc: AA2699C(2)_06-01_010

Rev	Date	Description	Dwn	Ckd
A	24.05.2016	Window reveal depths amended to suit installation design. Issued for Condition 15 Discharge & Planning approval.	MEF	RS
-	05.02.2016	Issued for Condition 15 Discharge & Planning approval.	MEF	RS

BICESTER ECO TOWN - PHASE 2
CONDITION 15
DETAILS - SHEET 3

AA2699C(2) 2512 **REV A**
PLANNING
Drawn MEF Checked RS Date JAN 2016 Scale @ A1 1:10