

NOTES

1. CONTRACTORS MUST CHECK ALL DIMENSIONS ON SITE. ONLY FIGURED DIMENSIONS ARE TO BE WORKED FROM. DISCREPANCIES MUST BE REPORTED TO THE ARCHITECT OR ENGINEER BEFORE PROCEEDING. © THIS DRAWING IS COPYRIGHT.
2. REPRODUCED FROM OS SITEMAP © BY PERMISSION OF ORDNANCE SURVEY® ON BEHALF OF THE CONTROLLER OF HER MAJESTY'S STATIONERY OFFICE. © CROWN COPYRIGHT 2008. ALL RIGHTS RESERVED. LICENCE NUMBER 100007126.
3. UNTIL TECHNICAL APPROVAL HAS BEEN OBTAINED FROM THE RELEVANT AUTHORITIES, ALL DRAWINGS ARE ISSUED AS PRELIMINARY AND NOT FOR CONSTRUCTION. SHOULD THE CONTRACTOR COMMENCE SITE WORK PRIOR TO APPROVAL BEING GIVEN IT IS ENTIRELY AT HIS OWN RISK.

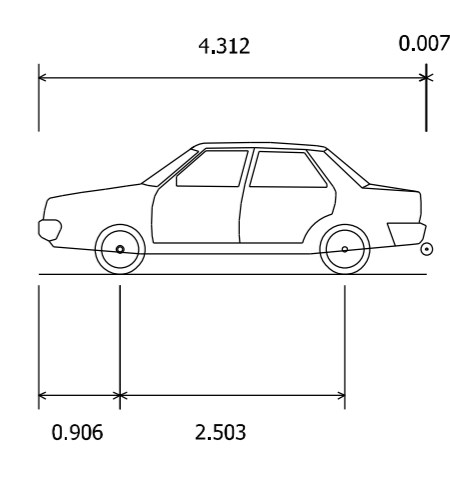

Medium Sized Car
 Overall Length 4.319m
 Overall Width 1.686m
 Overall Body Height 1.466m
 Min Body Ground Clearance 0.228m
 Max Track Width 1.591m
 Lock to Lock Time 4.00s
 Kerb to Kerb Turning Radius 5.042m

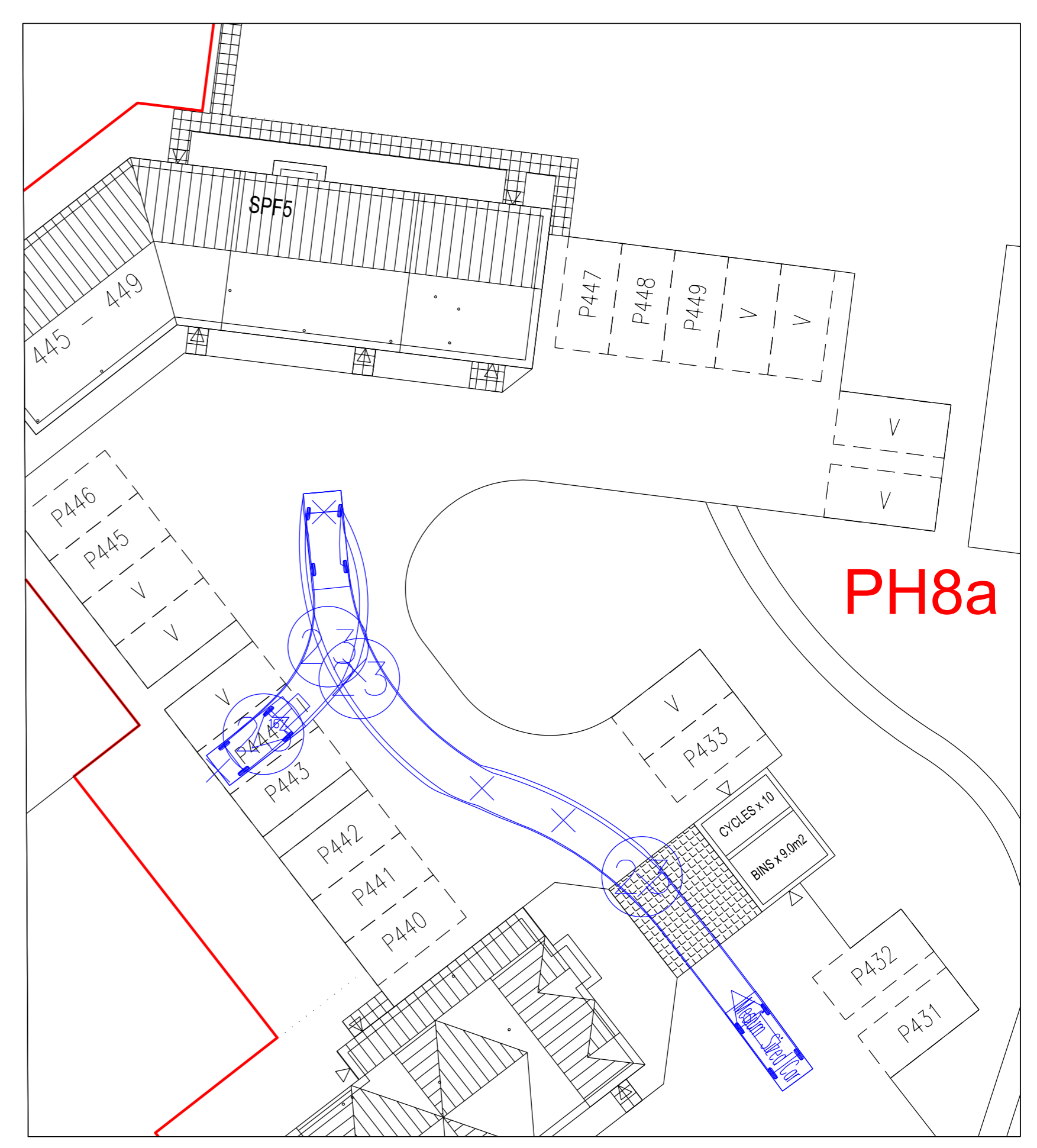
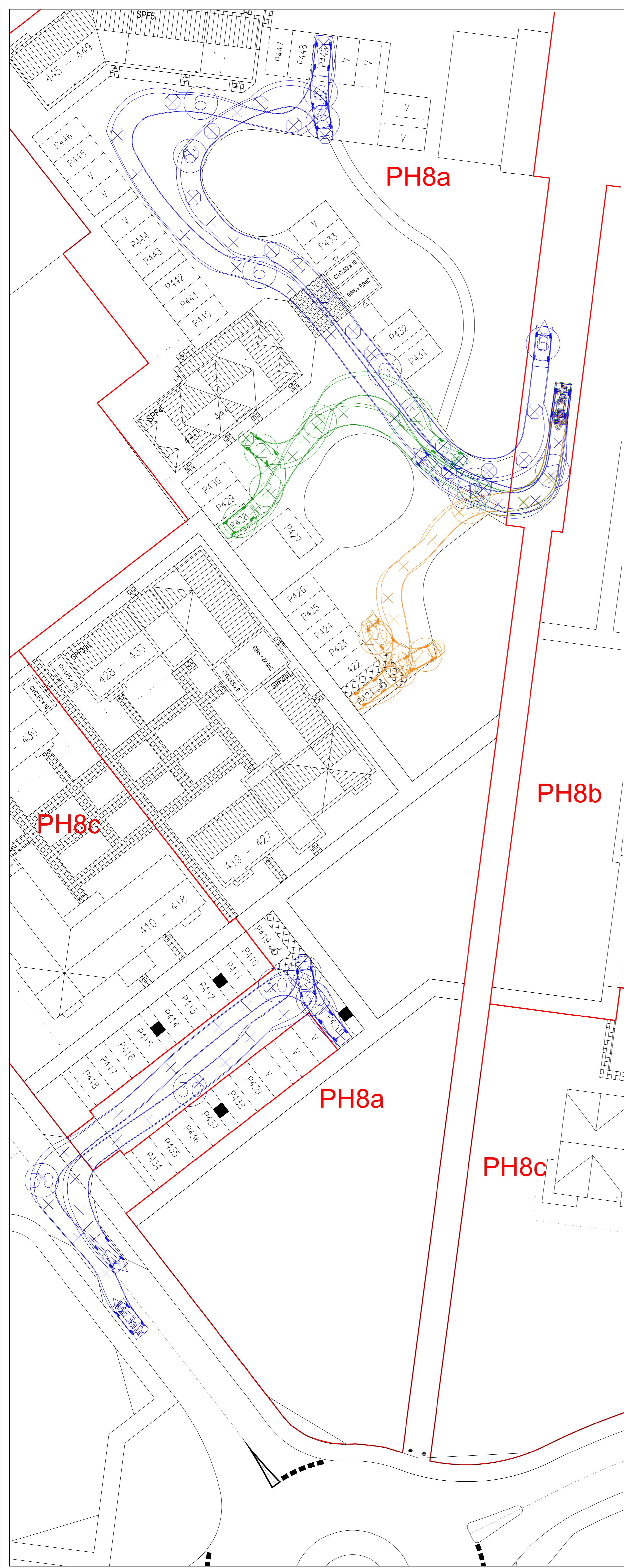

SUBJECT TO DETAILED DESIGN

UNTIL TECHNICAL APPROVAL HAS BEEN OBTAINED FROM THE RELEVANT AUTHORITIES, ALL DRAWINGS ARE ISSUED AS PRELIMINARY AND NOT FOR CONSTRUCTION. SHOULD THE CONTRACTOR COMMENCE SITE WORK PRIOR TO APPROVAL BEING GIVEN IT IS ENTIRELY AT HIS OWN RISK.

REVISION	DESCRIPTION	DRAWN	CHECKED	DATE
C	UPDATED TO SUIT LATEST LAYOUT AND SUB PARCEL DIVISIONS	AT	JF	05.03.18
B	LATEST SITE LAYOUT INDICATED	AT	JF	15.03.16
A	UPDATED TO SUIT LATEST SITE LAYOUT	AT	JF	27.01.16

PRELIMINARY INFORMATION TENDER CONSTRUCTION AS BUILT

WOODS HARDWICK
 ARCHITECTS, ENGINEERS AND DEVELOPMENT CONSULTANTS

TITLE: UPPER HEYFORD PARCEL D2b (PHASE 8)
 DETAILS: TRACKING

15-17 GOLDINGTON ROAD
 BEDFORD MK40 3RN
 UNITED KINGDOM
 T. +44 (0)1234 268862
 F. +44 (0)1234 353034
 MAIL@WOODSHARDWICK.COM
 WWW.WOODSHARDWICK.COM