

Client:
Richborough Estates & Lone Star Land

Project:
Heyford Park

Project No:
T19562
Report Title:
Transport Assessment

Prepared by: ML
Authorised by: JP
Rev:
Date: 15/12/2021

Hub Transport Planning Ltd
Radclyffe House
66/68 Hagley Road
Edgbaston
Birmingham
West Midlands B16 8PF
T. 0121 454 5530



TABLE OF CONTENTS

1.0	INTRODUCTION	1
2.0	POLICY REVIEW	2
3.0	BACKGROUND INFORMATION AND SUSTAINABILITY	6
4.0	SITE ACCESS	13
5.0	TRAFFIC GENERATION, DISTRIBUTION AND ASSIGNMENT	14
6.0	TRAFFIC IMPACT AND ASSESSMENT	15
7.0	SUMMARY AND CONCLUSION	26

FIGURES

1.1	Site Location Plan
3.1 & 3.2	2031 Reference Case Traffic Flows – Northern Junctions
3.3 & 3.4	2031 Reference Case Traffic Flows – Southern Junctions
3.5 & 5.6	2031 Reference Case + Development Traffic Flows – Northern Junctions
3.7 & 3.8	2031 Reference Case + Development Traffic Flows – Southern Junctions
3.9	Local Facilities Plan
3.10	Walk Distances Plan
3.11	Cycle Distance Plan

DRAWINGS

T19562.001 rev A	Site Access Junction with Visibility Splays and Crossing
T19562.002	Site Access Junction Swept Path Analysis 01

APPENDICES

Appendix A	Traffic Modelling Data (Bicester SATURN Model)
Appendix B	OCC Accident Data
Appendix C	Junction Impact Assessment
Appendix D	Junctions 10 Output – Site Access/Camp Road
Appendix E	LinSig Output – Camp Road/Chilgrove Drive
Appendix F	LinSig Output – Camp Road/Chilgrove Drive with Crossing
Appendix G	LinSig Output – B430/Unnamed Road
Appendix H	LinSig Output – B430/B4030 Middleton Stoney
Appendix I	Junctions 10 Output – B430/A4065
Appendix J	Junctions 10 Output – B4030/Unnamed Road
Appendix K	Junctions 10 Output – Camp Road/Kirklington Road
Appendix L	Junctions 10 Output – Camp Road/Somerton Road
Appendix M	Junctions 10 Output – A4260/Somerton Road/N Aston Road
Appendix N	Junctions 10 Output – A4095/Port Way

1.0 Introduction

Background

- 1.1 Hub Transport Planning Ltd has been commissioned by Richborough Estates and Lone Star Land to provide transport advice for a proposed residential development on land north of Camp Road, Heyford Park.
- 1.2 The application is for the erection of up to 230 dwellings, creation of a new vehicular access from Camp Road and all associated works; however, it should be noted that for the purpose of this report, we have considered a development of 250 dwellings to provide a robust assessment of the impacts, but which also allows for potential changes to the future housing density/mix at reserved matter stage.
- 1.3 The site location is shown on **Figure 1.1**.

Structure of the Report

- 1.4 This report is intended to determine the relevant highway issues and indicate potential solutions, with reference to the impact of the proposed development site off Camp Road, Heyford Park.
- 1.5 A Scoping Report has been submitted to Oxfordshire County Council (OCC) Transport Development Control (TDC) as the Local Highway Authority for comment. This Transport assessment (TA) reflects the technical and geographical scope agreed during pre-application discussions with the authority.
- 1.6 Following this introduction, the report is set out as follows:
 - Section 2.0 – Policy Review;
 - Section 3.0 – Background Information and Sustainability;
 - Section 4.0 – Site Access;
 - Section 5.0 – Traffic Generation, Distribution and Assignment;
 - Section 6.0 – Traffic Impact and Assessment;
 - Section 7.0 – Summary and Conclusion.

Limitations of the Report

- 1.7 This report has been undertaken at the request of Richborough Estates and Lone Star Land, thus should not be entrusted to any third party without written permission from Hub Transport Planning Ltd. However, should any information contained within this report be used by any unauthorised third party, it is done so entirely at their own risk and shall not be the responsibility of Hub Transport Planning Ltd.
- 1.8 This report has been compiled using data from several external sources (such as TRICS, traffic count data and public transport information); these sources are considered to be trustworthy and therefore the data provided is considered to be accurate and relevant at the time of preparing this report.

2.0 Policy Review

Introduction

2.1 This section summarises the relevant transport policy documents against which the development proposals are considered at a national, regional, and local level. The most relevant policy documents relating to this study are detailed below:

- National Planning Policy Framework (July 2021)
- Connecting Oxfordshire: Local Transport Plan 2015 to 2031
- The Cherwell Local Plan 2011 – 2031 (Adopted July 2015)

National Policy

2.2 The latest National Planning Policy Framework (NPPF) was published in July 2021 and sets out the Government's planning policies and how these are expected to be applied.

2.3 In relation to transport, the NPPF states at paragraph 105 that:

'The planning system should actively manage patterns of growth in support of these objectives. Significant development should be focused on locations which are or can be made sustainable, through limiting the need to travel and offering a genuine choice of transport modes. This can help to reduce congestion and emissions, and improve air quality and public health. However, opportunities to maximise sustainable transport solutions will vary between urban and rural areas, and this should be taken into account in both plan-making and decision-making.'

2.4 When considering the effects the development may have on the local transport network, the NPPF states that:

'In assessing sites that may be allocated for development plans, or specific applications for development, it should be ensured that:

a) appropriate opportunities to promote sustainable transport modes can be – or have been – taken up, given the type of development and its location;

b) safe and suitable access to the site can be achieved for all users;

c) the design of streets, parking areas, other transport elements and the content of associated standards reflects current national guidance, including the National Design Guide and the National Model Design Code; and

d) any significant impacts from the development on the transport network (in terms of capacity and congestion) or on highway safety, can be cost effectively mitigated to an acceptable degree.

Development should only be prevented or refused on highways grounds if there would be an unacceptable impact on highway safety, or the residual cumulative impacts on the road network would be severe.'

2.5 The NPPF further advises that:

‘Within this context, applications for development should:

- a) give priority first to pedestrian and cycle movements, both within the scheme and with neighbouring areas; and second – so far as possible – to facilitating access to high quality public transport, with layouts that maximise the catchment area for bus or other public transport services, and appropriate facilities that encourage public transport use;*
- b) address the needs of people with disabilities and reduced mobility in relation to all modes of transport;*
- c) create places that are safe, secure and attractive – which minimise the scope for conflicts between pedestrians, cyclists and vehicles, avoid unnecessary street clutter, and respond to local character and design standards;*
- d) allow for the efficient delivery of goods, and access by service and emergency vehicles; and*
- e) be designed to enable charging of plug-in and other ultra-low emission vehicles in safe, accessible and convenient locations.’*

2.6 In relation to parking policy the NPPF states that:

‘If setting local parking standards for residential and non-residential development, policies should take into account:

- a) the accessibility of the development;*
- b) the type, mix and use of development;*
- c) the availability of and opportunities for public transport;*
- d) local car ownership levels; and*
- e) the need to ensure an adequate provision of spaces for charging plug-in and other ultra-low emission vehicles.’*

Connecting Oxfordshire: Local Transport Plan 2015 to 2031

2.7 The Oxfordshire Local Transport Plan (LTP) sets out the County Council’s proposals for transport provision across the county.

2.8 The LTP contains several overarching policies that transport provision has a role in helping to achieve:

- *“Create a world class economy for Oxfordshire;*
- *Have healthy and thriving communities;*
- *Look after our environment and respond to the threat of climate change; and,*
- *Reduce inequalities and break the cycle of deprivation.”*

2.9 The following more specific goals are identified:

“Goal 1 - Supporting growth and economic vitality

- *Maintain and improve transport connections to support economic growth and vitality across the county;*

- *Make most effective use of all available transport capacity through innovative management of the network;*
- *Increase journey time reliability and minimise end-to-end public transport journey times on main routes; and*
- *Develop a high quality, innovative and resilient integrated transport system that is attractive to customers and generates inward investment.*

Goal 2 - Reducing Emissions

- *Minimise the need to travel;*
- *Reduce the proportion of journeys made by private car by making the use of public transport, walking and cycling more attractive;*
- *Influence the location and layout of development to maximise the use and value of existing and planned sustainable transport investment; and*
- *Reduce per capita carbon emissions from transport in Oxfordshire in line with UK Government targets.*

Goals 3, 4, 5 - Improving quality of life

- *Mitigate and wherever possible enhance the impacts of transport on the local built, historic and natural environment; and*
- *Improve public health and wellbeing by increasing levels of walking and cycling, reducing transport emissions, reducing casualties, and enabling inclusive access to jobs, education, training and services.”*

2.10 Various relevant policies are indicated throughout the document and certain relevant policies are included below:

- *“Policy 01: Oxfordshire County Council will work to ensure that the transport network supports sustainable economic and housing growth in the county, whilst protecting and where possible enhancing its environmental and heritage assets, and supporting the health and wellbeing of its residents.*
- *Policy 02: Oxfordshire County Council will manage and, where appropriate, develop the county’s road network to reduce congestion and minimise disruption and delays, prioritising strategic routes.*
- *Policy 03 Oxfordshire County Council will support measures and innovation that make more efficient use of transport network capacity by reducing the proportion of single occupancy car journeys and encouraging a greater proportion of journeys to be made on foot, by bicycle, and/or by public transport.*
- *Policy 07 Oxfordshire County Council will work with operators and other partners to enhance the network of high quality, integrated public transport services, interchanges, and supporting infrastructure, and will support the development of quality Bus Partnerships and Rail Partnerships, where appropriate.*
- *Policy 08 Oxfordshire County Council will work with partners towards the introduction and use of smart, integrated payment solutions for a range of transport modes.*
- *Policy 9 Oxfordshire County Council will work with the rail industry to enhance the rail network in Oxfordshire and connections to it, where this supports the county’s objectives for economic growth.*
- *Policy 18 Oxfordshire County Council will help reduce the need to travel by improving internet and mobile connectivity and other initiatives that enable people to work at or close to home.*

- *Policy 19 Oxfordshire County Council will encourage the use of modes of travel associated with healthy and active lifestyles.*
- *Policy 20 Oxfordshire County Council will carry out targeted safety improvements on walking and cycling routes to school, to encourage active travel and reduce pressure on school bus transport.*
- *Policy 22 Oxfordshire County Council will promote the use of low or zero emission transport, including electric vehicles and associated infrastructure where appropriate.*
- *Policy 26 Oxfordshire County Council will aim to record, protect, maintain and improve the public rights of way network so that users are able to understand and enjoy their rights in a safe and responsible way.*
- *Policy 30 Oxfordshire County Council will identify those parts of the highway network where significant numbers of accidents occur, and propose solutions to prevent accidents.*
- *Policy 34 Oxfordshire County Council will require the layout and design of new developments to proactively encourage walking and cycling, especially for local trips, and allow developments to be served by frequent, reliable and efficient public transport.”*

The Cherwell Local Plan 2011 – 2031

- 2.11 The Cherwell Local Plan sets out the proposals to promote the District by supporting the local economy and communities to the year 2031.
- 2.12 The Local Plan addresses transport and builds on the themes addressed in Connecting Oxfordshire. Policy SLE 4 highlights this:

“The Council will support the implementation of the proposals in the Movement Strategies and the Local Transport Plan to deliver key connections, to support modal shift and to support more sustainable locations for employment and housing growth.

We will support key transport proposals including:

- *Transport Improvements at Banbury, Bicester and the Former RAF Upper Heyford in accordance with the County Council’s Local Transport Plan and Movements Strategies*
- *Projects associated with East-West rail including new stations at Bicester Town and Water Eaton*
- *Rail freight associated development at Graven Hill, Bicester*
- *Improvements to M40 junctions.*

Consultations on options for new link and relief roads at Bicester and Banbury will be undertaken through the Local Transport Plan (LTP) review process. Routes identified following strategic options appraisal work for LTP4 will be confirmed by the County Council and will be incorporated into Local Plan Part 2.

New development in the District will be required to provide financial and/or in-kind contributions to mitigate the transport impact of development.

All development where reasonable to do so, should facilitate the use of sustainable modes of transport to make the fullest possible use of public transport, walking and cycling. Encouragement will be given to solutions which support reductions in greenhouse gas emissions and reduce congestion. Development which is not suitable for the roads that serve the development and which have a severe traffic impact will not be supported.”

3.0 Background Information and Sustainability

Site Location and Highway Network

- 3.1 The site is located on the eastern edge of Upper Heyford and borders the approved Heyford Park sustainable urban extension (SUE) on the former RAF airfield site.
- 3.2 The site is bounded by Camp Road to the south, Chilgrove Drive to the east, proposed commercial development area and bridleway of the Heyford Park development to the north, and a rural track to the west with the proposed Pye Homes development beyond.
- 3.3 Camp Road runs along the southern site frontage, from which the site will take access; Camp Road is the main through road for Upper Heyford, connecting the settlement with the wider highway network. It is subject to a 30mph speed limit and currently c.6.0m in width.
- 3.4 At present, footways are provided on both sides of the Camp Road carriageway west from Larsen Road; these continue into the settlement with dropped kerb and tactile paving crossing points across junctions. There are no footways along the site frontage at present.
- 3.5 The Camp Road/Chilgrove Drive junction to the east of the site is to be upgraded and changed into a signalised staggered junction as part of the Heyford Park SUE development. This involves the realignment of Chilgrove Drive to the east and realignment of the bridleway across Camp Road, as well as the incorporation of pedestrian, cyclist, and equestrian facilities at the junction crossings.
- 3.6 A new 1.5m footway is also proposed along the southern side of Camp Road up to a new zebra crossing facility adjacent to the southwest corner of the development site (as per Woods Hardwick drawing 16871-SK380 rev B).
- 3.7 Camp Road connects westwards to the B4030 beyond the settlement limits at Lower Heyford, then to the A4260 at Hopcrofts Holt c.6.4km from the site. East of the site, Camp Road connects to the B430 to the east and southeast of the site.
- 3.8 The B430 links northeast of the site onto the M40 at junction 10, whilst the B430/B4030 junction at Middleton Stoney provides further connection to the local urban areas of Bicester and Oxford.

Traffic Data

- 3.9 To provide a comprehensive assessment of the potential traffic impact of the proposed residential development, the Bicester SATURN Model has been run for the 2031 reference case, with and without proposed development traffic.
- 3.10 This provides turning movements at 26 local junctions, including the site access junction, these are as follows:
 - M40 Junction 10 (Padbury junction A43)
 - M40 Junction 10 (Cherwell Services junction A43)
 - M40 Junction 10 (Ardley junction A43/B430)
 - A43/B4100 roundabout

- A34 Northbound Slip Roads (B430)
 - A34 Southbound Slip Road (B430)
 - B430/Unnamed Road junction
 - B430/B4030 (Middleton Stoney) junction
 - A4095/B430 junction
 - A4095/B4030 junction
 - B4030/Unnamed Road junction
 - Camp Road/Kirklington Road junction
 - Camp Road/Somerton Road junction
 - B4030/Port Way junction
 - B4030/Station Road junction
 - A4260/Somerton Road junction
 - A4260/B4030 (Hopcrofts Holt) junction
 - A4260/Unnamed Road junction
 - A4230/Banbury Road/Unnamed Road junction
 - A4260/B4027 junction
 - A4095/Port Way junction
 - A4095/Bletchington Road junction
 - A4095/B4027 (Enslow east) junction
 - A4095/B4027 (Enslow west) junction
 - Camp Road/Chilgrove Drive signal junction
 - Site Access/Camp Road priority junction
- 3.11 The model outputs showing turning movements at these junctions for the AM peak, PM peak, and Inter Peak have been provided and included as **Appendix A**.
- 3.12 Traffic flow diagrams showing the 2031 reference case scenario without the proposed development and then with the proposed development are shown in **Figure 3.1 to 3.8**.

Highway Safety

- 3.13 To establish road safety conditions on the highway network in the vicinity of the site, Personal Injury Accident (PIA) data has been obtained from OCC and is included as **Appendix B**; the search area incorporates Upper/Lower Heyford, Heyford Park, Middleton Stoney and the B430/B4030 route.
- 3.14 The data from OCC provided covers the most recent five-and-a-half-year period available (01/01/2016 – 31/08/2021). A total of 20 PIAs have occurred in the search area, 13 classified as slight, six as serious and one fatal.

3.15 A summary of the accident data for the search area is included in Table 1.

Table 1 – Heyford Park PIAs

Location	Severity				Casualty Type	
	Slight	Serious	Fatal	Total	Pedestrian	Cyclist
Junctions						
B4030/Port Way	1	-	-	1	-	-
B4030/South Street	1	-	-	1	-	-
B4030/Park Farm Access	1	-	-	1	-	-
B4030/B430	-	1	-	1	-	-
B4030/Camp Road	3	-	-	3	-	1
Camp Road/Izzard Road	-	1	-	1	-	-
Camp Road/Kirtlington Road	-	1	-	1	-	1
Links						
Camp Road	4	1	-	5	1	-
Station Road	1	-	-	1	1	-
B4030	1	2	-	3	1	-
Port Way	-	-	1	1	-	-
B430	1	-	-	1	-	-
TOTAL	13	6	1	20	3	2

- 3.16 Two PIAs involved cyclists, one serious and one slight. Whilst three PIAs involved pedestrians, two were slight and one serious.
- 3.17 Camp Road passes south of the proposed site and west through the centre of Heyford Park. Along this route there have been a total of five accidents, two of which were slight, and three were serious. One of the serious accidents occurred at the Camp Road/Izzard Road junction, with another serious PIA occurring at the Camp Road/Kirklington Road junction.
- 3.18 Two slight PIAs have occurred along the Unnamed Road between Camp Road and the B4030, neither occurred at any junction.
- 3.19 Southeast of the site, at the Camp Road/B4030 junction, there have been 3 slight accidents, one of which involved a cyclist.
- 3.20 Along the B4030 south of Heyford Park there have been three accidents not at a junction, one of which was a serious accident. Two other PIAs occurred along this route at the Park Farm Access and at the B4030/South Street junction, both classified as slight.
- 3.21 There has also been one slight accident on the B430 not at junction, as well as one serious accident at the B430/Unnamed Road.
- 3.22 There has been one fatal accident in the vicinity of the site, on Port Way south of the B4030. The collision was a head on collision between two cars, due to a loss of concentration from one or both drivers.
- 3.23 The junction with the highest frequency of accidents is the B4030/Camp Road junction which only has 0.6 accidents per annum; the remaining junctions have just a single accident across the five-year period.
- 3.24 In respect of severity, it should also be noted that four of the six serious injury accidents were single vehicle incidents, and there is no indication in the accident description that any of the causation factors related to the highway network being defective in terms of design.

- 3.25 The causation factors were generally related to driver error, with one of the incidents relating to alcohol impairment being very likely; the pedestrian injury was caused by a child running into the road from behind a line of slow-moving traffic.
- 3.26 In addition, it should be noted that there are a number of mitigations schemes proposed for the highway network, including the signalisation of a number of priority junctions and HGV weight restrictions on the B4030.
- 3.27 Whilst all PIAs are regrettable, the analysis does not identify any specific accident patterns across the highway network in vicinity of the site; in addition, the number of accidents is not unusual given the level of traffic flow within the area.

Sustainable Transport

- 3.28 It is generally accepted that walking and cycling provide important alternatives to the car and should also be encouraged to form part of longer trips via public transport. Indeed, it is noteworthy that the Institute of highways and Transportation (IHT) has prepared several guidance documents that provide advice with respect to the provision of sustainable travel in conjunction with new developments. The suggested walking distances to common facilities is presented in **Table 2** below.

Table 2 – Suggested Walking Distances (IHT Guidelines)

	Town Centre (m)	Commuting/Schools/ Sightseeing (m)	Elsewhere
Desirable	200	500	400
Acceptable	400	1000	800
Preferred Maximum	800	2000	1200

- 3.29 In addition to the IHT guidance, Manual for Streets (MfS) states that ‘walkable neighbourhoods’ are typically characterised by having a range of facilities within 10 minutes (up to about 800m) walking distance of residential areas which residents may access comfortably on foot.
- 3.30 MfS also states that the 800m walking distance is not an upper limit and references the former PPG13 guidance in respect of walking replacing short car trips, particularly those under 2km.
- 3.31 The National Travel Survey (NTS) 2020, highlights the average cycle trip for 2019 was 6.1km (assuming a 10mph cycle speed).
- 3.32 In addition to the above, it is pertinent to note that the NTS (published in August 2020), which provides a summary of results of travel survey data for 2019, reports that the average walk trip distance is 1.36km.
- 3.33 As such, it is reasonable to assume that the average person will walk between 800m and 2.0km to a defined destination (such as local facilities), whilst also being mindful of the 1.36km average walk distance.
- 3.34 The following sections consider the opportunities for sustainable travel that are available in the vicinity of the site.

Local Facilities

- 3.35 Due to the neighbouring Heyford Park sustainable urban extension. Significant facilities, including employment opportunities, will start to appear across the area as the site undergoes development.

- 3.36 However, the current local facilities in the area are shown on **Figure 3.9** and include a pre-school, a secondary school (Heyford Park School), a Sainsbury’s Local foodstore, a dental clinic, a bicycle repair shop and an innovation centre.
- 3.37 The local facilities listed above are all within a 1.2km walking distance of the site and therefore accord with preferred maximum IHT walking distance guidance, as well as the average walk distance of 1.36km and upper limit of 2.0km indicated in MfS.

Table 3 – Local Facilities

Facility	Distance
Heyford Park School	800m
Sainsbury’s Local	850m
Heyford Bike Service & Repair/Spokes Coffee	900m
Heyford Smiles Dental Clinic	900m
Heyford Park Innovation Centre	1200m
Heyford Park Community Centre/Shop	1200m
Heyford Park Chapel	1250m
Heyford Park Gym	1700m
Heyford Park Nursery	1700m

- 3.38 The facilities indicated in **Table 3** demonstrate that the site is situated within a comfortable walking distance of local facilities for new residents of the development site, with the significant employment area to the north also being within a 1 to 2km walking/cycling distance.
- 3.39 A plan of the local area showing 800m, 1.2km, and 2.0km walk distances from the site can be seen in **Figure 3.10**; these are the walk distances set out in the IHT guidance.

Pedestrian Accessibility

- 3.40 There are existing PROWs around the site at present. There is currently a bridleway along Chilgrove Drive to the east of the proposed site, passing over the existing junction to the south. The closest pedestrian footway to the site starts adjacent to Camp Road on the south side, from Larsen Road, running all the way through the Heyford Park development site and into Upper Heyford village.
- 3.41 The site will deliver pedestrian access internally along the southern edge of the site, separated from Camp Road by the existing hedgerow. The footway will then join to Camp Road and to a pedestrian crossing just west of the access junction into the site.
- 3.42 Pedestrian connections are proposed east of the site onto Chilgrove Drive, which will become a bridleway as part of the wider Heyford Park development. These will also connect the site northwards into the Heyford Park development.

Cycle Accessibility

- 3.43 There are currently no dedicated cycle routes in the local area, the closest National Cycle Network (NCN) route is NCN 5 which connects Reading to Bangor through Oxford, approximately 8km west of the proposed site.

- 3.44 The neighbouring Heyford Park development will deliver both off and on-road cycle routes running along Camp Road. These will afford greater accessibility for people to use cycling as a form of transportation in the local area. The proposed downgrade of Chilgrove Drive to form a bridleway (with motor traffic being redirected to the east along a new road) and the crossing provision at the new signalised junction further enhances the local connectivity.
- 3.45 It is considered that a mix of on and off-road cycling provision is appropriate across the area and will ensure that cycling is a viable alternative for a number of short trips, including for education, leisure and commuting purposes.
- 3.46 A plan of the local area showing the 5.0km cycling distance around the site can be seen in **Figure 3.11**.

Bus Accessibility

- 3.47 The nearest bus stop to the site is located on Camp Road c.500m from the centre of the site, both stops currently are flagpole bus stops.
- 3.48 The neighbouring Pye Homes site directly to the west of the site has proposed delivery of a new bus stop within their Section 106 agreement, however it is noted that bus services will eventually use the realigned Chilgrove Drive access road into the wider Heyford Park site, rather than Camp Road.
- 3.49 Therefore, the proposed development will also deliver new bus stop provision on the access road adjacent to Chilgrove Drive for residents, as highlighted in OCCs pre-app response to the scope for this TA report. This will either be via Section 278 (if the new access road is complete), or via Section 106 agreement.

Table 4 – Local Bus Services

Service No.	Route	Frequency (approx.)		
		Mon-Fri	Sat	Sun
250	Upper Heyford • Bicester	60 mins	60 mins	-

- 3.50 The journey time to Bicester takes approximately 15 to 20 minutes and runs from just after 6am in the morning until just before 8pm in the evening, Monday to Saturday.
- 3.51 OCC has indicated that contributions will be required towards the public transport strategy for Heyford Park.
- 3.52 There are currently plans to improve the frequency and hours of operation of the 250 bus service, such that it can deliver up to a 15-minute frequency in the future, with financial contributions to be secured from development site at a rate of £1,051 per dwelling.
- 3.53 Based on the 250 dwellings assessed in this report, this will result in a total contribution of £262,750 towards the public transport strategy for the Heyford Park area.

Rail Accessibility

- 3.54 The nearest rail station to the site is Heyford Station approximately 4.5km southwest of the site, located in Lower Heyford. Additionally, Bicester North and Bicester Village rail stations are both approximately 9km southeast of the site.
- 3.55 Great Western Railways operate the line from Heyford Station which runs from Banbury to Didcot Parkway via Oxford. Services are provided approximately every 90-120 minutes with reduced services on Sundays. From

Oxford, there are onward direct connections to London Paddington. The journey time from Heyford to Banbury is approximately 18 minutes and to Oxford is approximately 16 minutes. Heyford train station is an unstaffed station, with 28 car parking spaces as well as 4 cycle parking spaces with CCTV coverage.

- 3.56 Bicester Village Station provides a service between London Marylebone and Oxford approximately every 30 minutes, whilst Bicester North provides a service between London Marylebone and Banbury approximately every 60 minutes and a service between London Marylebone and Birmingham Snow Hill approximately every 60 minutes.
- 3.57 Bicester Village and Bicester North stations are easily accessible via the 250 bus service, taking approximately 25 minutes (including the walking time from the relevant stops).

Summary

- 3.58 The above review demonstrates that the site is accessible by a variety of modes of transport that have the potential to reduce reliance upon the private car.
- 3.59 It is therefore considered that residents suitable alternatives for travel and that the proposals therefore accord with the guiding principles of the NPPF.

4.0 Site Access

Vehicular Access Strategy

- 4.1 Vehicular access to the site is proposed north off Camp Road, along the southern frontage of the site.
- 4.2 The proposed site access junction will take the form of a new priority T-junction with Camp Road and is shown on **Drawing T19562.001 rev A**; footway provision on the western side is 2.0m in width, with shared footway/cycleway provision on the eastern side at 3.0m width.
- 4.3 The site access has been agreed in principle with OCC, subject to capacity analysis.
- 4.4 Visibility at the junction is provided in accordance with the prevailing speed limit of 30mph, with 2.4m x 59m splays in both directions, in line with MfS standards.
- 4.5 The proposal for the signalisation of the Chilgrove Drive junction to the east will ensure that westbound traffic speeds are controlled as traffic negotiates the new layout.
- 4.6 The site access drawing shows the traffic-calming feature along Camp Road that has been agreed as part of the wider Heyford Park development, which proposes a zebra crossing and carriageway narrowing to 3.7m.
- 4.7 As part of the site access junction layout, the narrowing is proposed to be moved slightly; this has also been agreed in principle with OCC.
- 4.8 The swept path analysis for the site access is provided in **Drawing T19562.002**. This demonstrates that the arrangement can accommodate a large refuse vehicle accessing the site once a week.

Pedestrian/Cycle Access Strategy

- 4.9 The pedestrian and cycle route provision runs eastward within the site towards the proposed signal junction, separated from the carriageway by existing hedgerow.
- 4.10 The 2.0m footway on the western side of the site access continues along Camp Road before tying into existing infrastructure.
- 4.11 The zebra crossing proposed at the narrowing will connect to new footway/cycleway provision on the southern side of Camp Road which continues eastward towards the bridleway.
- 4.12 Further pedestrian and cycle links are to be provided from within the site onto the rearranged bridleway connection on Chilgrove Drive to the east, and these are shown on the illustrative masterplan; therefore, connections will be provided to the pedestrian/cycle network associated with the wider Heyford Park development.

Internal Road Layout

- 4.13 The internal road network for the site will be designed in line with OCC's Residential Road Design Guide and the principles set out in Manual for Streets, providing a 5.5m carriageway width for the primary route through the development, reducing to 4.8m carriageway width/6.0m shared surface provision to provide access along the residential access streets.

5.0 Traffic Generation, Distribution and Assignment

Traffic Generation

- 5.1 The traffic generation for the proposed development has utilised the agreed trip rates from the wider Heyford Park TA, these have been agreed with OCC.
- 5.2 The resulting forecast trip generation of the site is presented in **Table 5**.

Table 5 – TRICS Vehicle Trip Rates – 250 Dwellings

Peak Period	Trip Rate (per Dwelling)		Trips (250 Dwellings)		Total
	In	Out	In	Out	
AM	0.147	0.452	37	113	150
PM	0.319	0.165	80	41	121

NB: AM peak is 08:00-09:00 and PM peak is 17:00-18:00; trips have been rounded.

- 5.3 **Table 5** indicates that the proposed development is forecast to result in 150 two-way vehicle movements during the AM peak hour and 121 two-way vehicle movements during the PM peak hour.
- 5.4 This is equivalent to between two and three additional two-way vehicle movements per minute on the local highway network during any given peak hour.

Distribution and Assignment

- 5.5 The traffic distribution and assignment for the proposed development has been derived using the approved SATURN Model, which we commissioned Tetra Tech to update to incorporate the development site.
- 5.6 The modelling methodology uses the 2031 Kingsmere Update with Heyford Park scenario (created in September 2021) as the Reference Case model.
- 5.7 This includes the Heyford Park development (Policy Villages 5 in Cherwell Local Plan) and its associated highway mitigation works (which were agreed with OCC in September 2021).
- 5.8 The junctions included within the model outputs are set out in paragraph 3.10.
- 5.9 The 2031 With Development scenario has been developed using the Reference Case scenario, with the creation of a new zone for the proposed development.
- 5.10 The Variable Demand Model (VDM) has then been updated to include the new zone and subsequently run, with manual adjustments then made by Tetra Tech to ensure that the vehicles trips associated with the new zone match those set out in **Table 5** above.
- 5.11 The VDM output matrices were then checked and assigned to the model, with the turning movements subsequently extracted for the 2031 With Development scenario so that junction impact and capacity analysis can be undertaken.
- 5.12 The analysis is set out in **Section 6.0**.

6.0 Traffic Impact and Assessment

Introduction

6.1 This section sets out the results of the junction impact analysis and junction modelling undertaken to assess the impact of the proposed development across the local highway network.

Traffic Impacts

6.2 An initial impact assessment has been completed in respect of the junction data provided for the 25 junctions within the Bicester SATURN model.

6.3 The results of the impact assessment are provided as **Appendix C** to this report.

6.4 The assessment demonstrates that across the vast majority of the highway network, the development traffic is negligible.

6.5 At the M40 junctions, the junction impacts range from 0.10% to 0.55% in the morning and evening peak hours; as such, it is not considered necessary to undertake any further analysis at these locations.

6.6 Across the remainder of the local highway network, the development traffic impacts are largely negligible with 14 of the junctions showing impacts below 1.0% in both peak hours.

6.7 At the remaining eight junctions, the development traffic junction impacts range from 1.0% to 6.0%, with approach arm impacts generally in a similar range except for a few junctions where they exceed 10.0%.

6.8 Overall, the impacts fall within what would be expected to be normal daily variation in traffic flows through those junctions.

6.9 However, in addition to the Camp Road site access junction assessment, we consider that the following junctions merit detailed analysis for the reasons highlighted, to understand the impacts of the development and identify any further mitigation that might be necessary:

- Junction 7 – B4030/Unnamed Road junction – c.6.0% AM peak impact along an approach arm;
- Junction 8 – B430/B4030 (Middleton Stoney) junction – c.2.0 to 2.5% AM and PM peak impact along an approach arm, however this junction has known capacity issues;
- Junction 9 – A4095/B430 junction – c.6.0% PM peak impact along an approach arm;
- Junction 11 – B430/Unnamed Road (New signalised arrangement) – c.38.0% and 17.0% AM and PM peak impacts along an approach arm, in addition to c.5.0% junction impacts overall in both peak periods;
- Junction 12 – Camp Road/Kirklington Road junction – c.4.0% and 6.0% AM and PM peak impacts along an approach arm, in addition to c.3.0% junction impacts overall in both peak periods;
- Junction 13 – Camp Road/Somerton Road junction – c.5.5% and 4.0% AM and PM peak impacts along an approach arm, in additional to c.3.0% junction impacts overall in both peak periods;
- Junction 16 – A4260/Somerton Road/N Aston Road junction – c.5.5% and 3.5% AM and PM peak impacts along an approach arm;
- Junction 21 – A4095/Port Way junction – c.5.0% AM peak impact along an approach arm.

- Junction 25 – Camp Road/Chilgrove Drive (New signalised staggered arrangement) – c.12.0% and 10.5% AM and PM peak impacts along an approach arm, in addition to c.6.0% junction impacts overall in both peak periods.
- 6.10 Aside from the Camp Road site access junction (as it only exists in the development scenario), the capacity assessments have been carried out for the following traffic scenarios:
- 2031 Reference Case;
 - 2031 Reference Case + Development.

Proposed Camp Road Site Access Junction

- 6.11 The proposed Camp Road site access junction has been assessed using the PICADY module of the Junctions 10 software package.
- 6.12 The summary results are set out in **Table 6** below, with the full PICADY outputs included as **Appendix D**.

Table 6 – Site Access Junction – PICADY Analysis

Approach	AM Peak 08:00-09:00			PM Peak 17:00-18:00		
	RFC	Queue	Delay (s)	RFC	Queue	Delay (s)
2031 Reference Case + Development						
Site Access	0.29	0	12	0.09	0	8
Camp Road RT	0.07	0	6	0.13	0	5

- 6.13 **Table 6** demonstrates that the proposed site access junction is forecast to operate well within capacity in the future year of 2031, with minimal queues and delays at both the site access and along Camp Road.

Highway Network Junction Capacity Assessments

Methodology

- 6.14 All priority junctions assessed have been modelled using the PICADY module of the Junctions 10 software.
- 6.15 All signalised junctions have been modelled using the LinSig 3 junction software; all queues are robustly shown as mean max queues (PCUs).

Camp Road/Chilgrove Drive (New signalised staggered arrangement)

- 6.16 The revised Camp Road/Chilgrove Drive signalised junction has been approved as part of the wider Heyford Park SUE development.
- 6.17 As such the geometries and signal timings have been taken from the TA and subsequent addendums; whilst we are proposing a minor increase in the length of the right-turn lane, the previous modelling is retained to provide a robust assessment (it is worth noting that there are few right-turners in any case, thus it makes a negligible difference either way).
- 6.18 A summary of the results for the assessment of the Camp Road/Chilgrove Drive junction arrangement to the east of the development is provided in **Table 7**, with the full output results included in **Appendix E**.

- 6.19 The junction has been modelled using a 75 second cycle for the peak hours.
- 6.20 It should be noted that it is likely that the junctions would be run using a MOVA system which provides additional capacity benefits compared to the fixed cycle times assessed in this report.

Table 7 – Camp Road/Chilgrove Drive – LinSig Summary Results

Approach	AM Peak 08:00-09:00			PM Peak 17:00-18:00		
	Sat (%)	Queue	Delay (s)	Sat (%)	Queue	Delay (s)
2031 Reference Case						
Unnamed Road (E)	76.9	6	28	48.7	2	39
Unnamed Road (S)	53.0	6	18	46.6	3	20
Camp Road	75.5	12	28	22.1	3	14
Chilgrove Drive	77.0	8	45	51.7	6	10
Internal (WB) Left	3.3	0	26	6.0	1	14
Internal (WB) Ahead	10.5	1	16	13.9	1	8
Internal (EB) Left	33.5	5	7	45.8	4	34
Internal (EB) Ahead	45.4	6	14	45.8	2	22
Cycle Time (s)	75			75		
PRC (%)	16.8			74.1		
Delay (PCU/Hr)	18.00			10.54		
2031 Reference Case + Development						
Unnamed Road (E)	81.0	7	31	51.6	2	38
Unnamed Road (S)	59.3	7	21	41.1	3	14
Camp Road	76.4	14	25	33.0	4	20
Chilgrove Drive	81.3	8	48	51.9	6	10
Internal (WB) Left	3.0	0	15	8.2	1	29
Internal (WB) Ahead	10.4	1	14	21.9	2	15
Internal (EB) Left	33.9	0	5	45.8	4	40
Internal (EB) Ahead	48.7	1	14	50.3	3	17
Cycle Time (s)	75			75		
PRC (%)	10.7			73.3		
Delay (PCU/Hr)	19.66			11.06		

- 6.21 **Table 7** demonstrates that the committed signal scheme and realignment would operate well within capacity during the AM and PM peak periods for the 2031 reference case scenario, including with the additional development traffic on the network.
- 6.22 The junction arrangement shows a Pegasus Crossing across the western arm of the junction on Camp Road; however, this has not been included within the initial junction modelling due to its forecast infrequent use.
- 6.23 That said, to ensure a robust test of the junction, sensitivity analysis has been carried out including a crossing phase and resulting all red phase for the traffic approaches at the junction .

- 6.24 With the crossing included, the junction has been modelled using a 110 second cycle time for each of the peak hours; it should also be noted that the crossing is modelled as being called every cycle, thus is considered to be an exceptionally robust test.
- 6.25 A summary of the results for the assessment of the new Camp Road/Chilgrove Drive junction arrangement with Pegasus Crossing included is provided in **Table 8**, with the full output results included in **Appendix F**.

Table 8 – Camp Road/Chilgrove Drive with Crossing – LinSig Summary Results

Approach	AM Peak 08:00-09:00			PM Peak 17:00-18:00		
	Sat (%)	Queue	Delay (s)	Sat (%)	Queue	Delay (s)
2031 Reference Case						
Unnamed Road (E)	72.8	8	31	50.3	3	51
Unnamed Road (S)	77.7	13	46	49.7	5	30
Camp Road	76.3	18	37	31.6	5	30
Chilgrove Drive	76.3	11	54	50.7	8	11
Internal (WB) Left	3.3	0	14	8.6	1	21
Internal (WB) Ahead	10.6	2	22	19.8	4	42
Internal (EB) Left	31.8	9	9	44.8	2	21
Internal (EB) Ahead	43.2	8	17	44.8	7	42
Cycle Time (s)	110			110		
PRC (%)	15.9			77.4		
Delay (PCU/Hr)	25.38			14.83		
2031 Reference Case + Development						
Unnamed Road (E)	74.6	9	31	50.7	3	49
Unnamed Road (S)	82.4	14	50	51.0	7	27
Camp Road	83.6	21	41	39.8	6	35
Chilgrove Drive	78.7	11	57	51.0	8	11
Internal (WB) Left	3.2	0	13	9.8	1	25
Internal (WB) Ahead	11.3	2	22	26.5	5	33
Internal (EB) Left	32.4	10	8	44.8	6	29
Internal (EB) Ahead	46.6	10	18	49.1	8	64
Cycle Time (s)	110			110		
PRC (%)	7.7			76.4		
Delay (PCU/Hr)	28.73			17.66		

- 6.26 **Table 8** demonstrates that if the crossing phase is implemented into the modelling, the signal junction is still forecast to operate well within capacity during the AM and PM peak periods for the 2031 reference case scenario and with additional development traffic on the network.
- 6.27 On the basis of the above, no further mitigation is required at this junction.

B430/Unnamed Road (New signalised layout)

- 6.28 The signalisation of the current B430/Unnamed Road priority T-junction is a committed scheme from the wider Heyford Park SUE development. The geometries and signal timings have been taken from the TA and subsequent addendums for that site.
- 6.29 A summary of the results for the assessment of the B430/Unnamed Road junction signalisation to the east of the development is provided in **Table 9**, with the full output results included in **Appendix G**.
- 6.30 The junction has been modelled using a 90 second cycle for the peak hours.
- 6.31 It should be noted that it is likely that the junctions would be run using a MOVA system which provides additional capacity benefits compared to the fixed cycle times assessed in this report.

Table 9 – B430/Unnamed Road Signalisation – LinSig Summary Results

Approach	AM Peak 08:00-09:00			PM Peak 17:00-18:00		
	Sat (%)	Queue	Delay (s)	Sat (%)	Queue	Delay (s)
2031 Reference Case						
B430 (N)	87.8	19	34	70.7	14	29
B430 (S)	72.7	4	76	64.8	8	40
Unnamed Road	88.4	20	29	71.9	10	19
Cycle Time (s)	90			90		
PRC (%)	1.8			25.1		
Delay (PCU/Hr)	20.76			13.90		
2031 Reference Case + Development						
B430 (N)	91.4	22	42	71.3	14	30
B430 (S)	70.5	4	73	69.0	8	44
Unnamed Road	90.0	22	30	72.7	11	18
Cycle Time (s)	90			90		
PRC (%)	-1.6			23.8		
Delay (PCU/Hr)	23.50			14.47		

- 6.32 **Table 9** demonstrates that in the 2031 reference case scenario, the committed signal scheme would operate well within capacity for the PM peak period, while in the AM peak period the junction is approaching capacity.
- 6.33 The addition of the development traffic to the 2031 reference case results in an overall decrease in the PRC of the junction and, in the morning peak hour, indicates a marginally negative PRC.
- 6.34 However, the relative change in queues and delays at the junction during both peak hours is negligible.
- 6.35 It should also be noted that in terms of traffic impact percentage, the development traffic would have an overall junction impact of 2.26% in the AM peak hour and 1.22% in the PM peak hour; and in addition to this, the use of a MOVA controller would provide an additional capacity benefit to the junction that cannot be modelled within a fixed LinSig cycle.

6.36 On the basis of the analysis, no further mitigation is required at this junction.

B430/B4030 (Middleton Stoney) junction

6.37 The geometry and signal timings for the existing signalised staggered junction within the centre of Middleton Stoney have been taken from the Heyford Park SUE TA and subsequent addendums as it was formally assessed as part of that application, with an approved mitigation scheme.

6.38 A summary of the results is provided in **Table 10**, with the full output results included in **Appendix H**.

6.39 The junction has been modelled using a 120 second double-cycle for the peak hours.

6.40 It should be noted that it is likely that the junctions would be run using a MOVA system which provides additional capacity benefits compared to the fixed cycle times assessed in this report.

Table 10 – B430/B4030 (Middleton Stoney) Junction with Mitigation – LinSig Summary Results

Approach	AM Peak 08:00-09:00			PM Peak 17:00-18:00		
	Sat (%)	Queue	Delay (s)	Sat (%)	Queue	Delay (s)
2031 Reference Case						
B4030 Bicester Road	149.8	126	712	147.3	121	688
B430 Oxford Road	52.5	5	20	195.8	186	983
B4030 Heyford Road	30.4	1	75	31.3	1	75
B430 Ardley Road	154.9	285	751	120.6	121	381
Cycle Time (s)	120			120		
PRC (%)	-72.2			-117.6		
Delay (PCU/Hr)	388.88			398.90		
2031 Reference Case + Development						
B4030 Bicester Road	153.4	130	744	146.1	118	678
B430 Oxford Road	52.5	5	20	191.7	186	957
B4030 Heyford Road	30.4	1	75	31.3	1	75
B430 Ardley Road	154.4	288	746	121.1	123	389
Cycle Time (s)	120			120		
PRC (%)	-71.6			-113.0		
Delay (PCU/Hr)	394.75			398.58		

6.41 **Table 10** demonstrates that the committed mitigation scheme to the existing signal junction will operate well over capacity during the AM and PM peak periods.

6.42 The addition of the development traffic to the 2031 reference case scenario results in a slight improvement to the PRC of the junction for both the AM and PM peak hours; this is essentially due to the reassignment effects within the Bicester SATURN model.

6.43 During the AM peak hour, Bicester Road is forecast to experience a slight increase in queuing and delays while Ardley Road is forecast to experience a slight increase in queuing but a slight decrease in delays.

- 6.44 During the PM peak hour, Bicester Road is forecast to experience a slight decrease in both queuing and delays while Ardley Road is forecast to experience a slight increase in queuing and delays.
- 6.45 It is clear from the results that the impact of the additional development traffic at the junction is negligible; as such, no further mitigation is required at this junction.

A4095/B430 junction

- 6.46 A summary of the results for the capacity assessment of the A4095/B430 priority junction to the southeast of the development is provided in **Table 11**, with full output and results included in **Appendix I**.
- 6.47 Following observations of the current junction operation, with the alignment of the approaches to the junction (specifically the minor arms lining up for cross movements), the junction has been modelled as a crossroads junction with two-lanes.
- 6.48 This is because cross movements from the A4095 (W) to the A4095 (E), and vice-versa, are undertaken in a single movement, despite the very slight stagger.
- 6.49 The modelling is therefore considered to be representative of the observed junction operation.

Table 11 – A4095/B430 Staggered Priority Junction – PICADY Analysis

Approach	AM Peak 08:00-09:00			PM Peak 17:00-18:00		
	RFC	Queue	Delay (s)	RFC	Queue	Delay (s)
2031 Reference Case						
A4095 (W) Left/Ahead	0.59	2	16	0.78	3	33
A4095 (W) Right/Ahead	0.34	1	11	0.39	1	13
B430 (S)	0.00	0	7	0.05	0	6
A4095 (E) Left/Ahead	0.39	1	17	0.51	1	23
A4095 (E) Right/Ahead	0.54	1	29	0.44	1	20
B430 (N)	0.07	0	6	0.05	0	6
2031 Reference Case + Development						
A4095 (W) Left/Ahead	0.59	2	17	0.77	3	33
A4095 (W) Right/Ahead	0.35	1	11	0.39	1	13
B430 (S)	0.00	0	7	0.05	0	6
A4095 (E) Left/Ahead	0.39	1	17	0.56	1	25
A4095 (E) Right/Ahead	0.56	1	30	0.50	1	24
B430 (N)	0.07	0	6	0.05	0	7

- 6.50 **Table 11** demonstrates that in the 2031 future year scenario, the addition of the development traffic flow through the junction results in a negligible change to the queuing and delays across all arms of the junction.
- 6.51 As such, it is considered that the impact of the proposed development is negligible and no mitigation is required.

B4030/Unnamed Road Junction

- 6.52 A summary of the results for the capacity assessment of the B4030/Unnamed Road priority junction to the southeast of the development is provided in **Table 12**, with full output and results included as **Appendix J**.
- 6.53 The Bicester SATURN model includes this junction with its current layout; therefore, whilst it is noted that proposals are being considered in respect of changing the priority at the junction alongside the provision of a southbound bus gate to the southern arm, it has been modelled within this report as per the existing junction arrangements.

Table 12 – B4030/Unnamed Road Priority Junction (Existing Arrangement) – PICADY Analysis

Approach	AM Peak 08:00-09:00			PM Peak 17:00-18:00		
	RFC	Queue	Delay (s)	RFC	Queue	Delay (s)
2031 Reference Case						
Unnamed Road (LT)	0.01	0	8	0.01	0	7
Unnamed Road (RT)	0.07	0	10	0.13	0	10
B4030	0.71	3	16	0.60	2	12
2031 Reference Case + Development						
Unnamed Road (LT)	0.01	0	8	0.01	0	8
Unnamed Road (RT)	0.12	0	10	0.15	0	10
B4030	0.74	3	18	0.65	2	13

- 6.54 **Table 12** demonstrates that the existing junction will operate within capacity in the 2031 Reference Case scenario and that the addition of the development traffic at the junction results in a negligible change in queuing and delays across all arms.
- 6.55 As such, it is considered that the impact of the proposed development is negligible, and no mitigation is required.

Camp Road/Kirklington Road Junction

- 6.56 A summary of the results for the capacity assessment of the Camp Road/Kirklington Road priority junction to the west of the development is provided in **Table 13**, with full output and results included in **Appendix K**.

Table 13 – Camp Road/Kirklington Road Priority Junction – PICADY Analysis

Approach	AM Peak 08:00-09:00			PM Peak 17:00-18:00		
	RFC	Queue	Delay (s)	RFC	Queue	Delay (s)
2031 Reference Case						
Kirklington Road	0.16	0	11	0.27	0	12
Camp Road	0.00	0	0	0.00	0	0
2031 Reference Case + Development						
Kirklington Road	0.16	0	11	0.27	0	12
Camp Road	0.00	0	0	0.00	0	0

- 6.57 **Table 13** demonstrates that the existing junction will operate well within capacity in the 2031 Reference Case scenario, with minimal queues and delays, and that the addition of the development traffic at the junction results in no change in queuing or delays.
- 6.58 As such, it is considered that the impact of the proposed development is negligible, and no mitigation is required.

Camp Road/Somerton Road Junction

- 6.59 A summary of the results for the capacity assessment of the Camp Road/Somerton Road priority junction to the west of the development is provided in **Table 14**, with full output and results included in **Appendix L**.

Table 14 – Camp Road/Somerton Road Priority Junction – PICADY Analysis

Approach	AM Peak 08:00-09:00			PM Peak 17:00-18:00		
	RFC	Queue	Delay (s)	RFC	Queue	Delay (s)
2031 Reference Case						
Camp Road	0.48	1	14	0.41	1	12
Somerton Road	0.13	0	7	0.12	0	6
2031 Reference Case + Development						
Camp Road	0.51	1	15	0.43	1	12
Somerton Road	0.13	0	7	0.13	0	6

- 6.60 **Table 14** demonstrates that the existing junction will operate well within capacity in the 2031 Reference Case scenario, with minimal queues and delays, and that the addition of the development traffic at the junction results in a negligible change in queuing and delays.
- 6.61 As such, it is considered that the impact of the proposed development is negligible, and no mitigation is required.

A4260/Somerton Road/N Aston Road Crossroads Junction

- 6.62 A summary of the results for the capacity assessment of the A4260/Somerton Road/N Aston Road crossroads junction to the northwest of the development is provided in **Table 15**, with full output and results included in **Appendix M**.
- 6.63 It should be noted that, based on observations of the operation of the junction during peak hours, the minor road approaches to the junction have been modelled with a flare of 0.5 PCUs; this is due to the fact that if a left-turning vehicle is waiting at the give-way line on either side of the A4260, a right-turning vehicle can sit alongside it.
- 6.64 However, if either the right-turning vehicle, or two left-turning vehicles approach first, then the flare is not available.
- 6.65 As such, our observations suggest that the 1.0 PCU flare at each minor arm approach operates effectively around 50% of the time; hence a flare of 0.5 PCUs for each approach.

Table 15 – A4260/Somerton Road/N Aston Road Staggered Priority Junction – PICADY Analysis

Approach	AM Peak 08:00-09:00			PM Peak 17:00-18:00		
	RFC	Queue	Delay (s)	RFC	Queue	Delay (s)
2031 Reference Case						
N Aston Road LT	0.25	0	28	0.24	0	35
N Aston Road RT	0.24	0	26	0.23	0	35
A4260 (N)	0.00	0	6	0.02	0	9
Somerton Road LT	1.43	13	606	0.20	0	23
Somerton Road RT	1.41	11	597	0.50	1	41
A4260 (S)	0.08	0	13	0.03	0	7
2031 Reference Case + Development						
N Aston Road LT	0.25	0	28	0.26	0	36
N Aston Road RT	0.24	0	26	0.24	0	37
A4260 (N)	0.00	0	6	0.02	0	9
Somerton Road LT	1.56	14	694	0.21	0	24
Somerton Road RT	1.54	14	678	0.52	1	43
A4260 (S)	0.08	0	13	0.03	0	7

- 6.66 **Table 15** demonstrates that during the 2031 future year scenarios the Somerton Road approach arm is operating beyond capacity during the AM peak hour, but well within capacity during the PM peak hour.
- 6.67 An RFC of 1.41 and 1.43 in the AM peak hour is beyond the modelling capabilities of the Junctions 10 software and, as such, results should be treated with a significant degree of caution.
- 6.68 The addition of the development traffic flows through the junction result in a very minor change to the queuing and delays at the junction.
- 6.69 This is the case even taking into account the fact that the junction is operating beyond the modelling capabilities of the software.
- 6.70 In respect of the additional traffic passing through the junction, in the AM peak hour there are just seven additional PCUs added to the Somerton Road approach arm as a result of the development traffic.
- 6.71 On the basis of the above, it is considered that the impact of the proposed development is negligible, and no mitigation is required.

A4095/Port Way Junction

- 6.72 A summary of the results for the capacity assessment of the A4095/Port Way priority junction to the south of the development is provided in **Table 16**, with full output and results included in **Appendix N**.

Table 16 – A4095/Port Way Priority Junction – PICADY Analysis

Approach	AM Peak 08:00-09:00			PM Peak 17:00-18:00		
	RFC	Queue	Delay (s)	RFC	Queue	Delay (s)
2031 Reference Case						
A4095 (E) LT	0.29	0	9	0.42	1	10
A4095 (E) RT	0.15	0	15	0.18	0	16
A4095 (S)	0.67	2	19	0.78	4	23
2031 Reference Case + Development						
A4095 (E) LT	0.29	0	9	0.41	1	10
A4095 (E) RT	0.15	0	15	0.18	0	16
A4095 (S)	0.68	2	20	0.78	4	23

- 6.73 **Table 16** demonstrates that during the 2031 future year scenarios the junctions operates within capacity with limited minimal queuing and delays across all arms.
- 6.74 The addition of the development traffic flows through the junction result in a negligible change to the operation of the junction and, as such, no mitigation is required.

Analysis Summary

- 6.75 The analysis summarised above demonstrates that for the 2031 Reference Case scenario, many of the junctions across the local highway network are operating well within capacity, whilst some are either approaching capacity (or are over capacity) even with the proposed mitigation schemes modelled.
- 6.76 However, the analysis also demonstrates that the addition of development traffic to the 2031 reference case at the junctions assessed is considered to have a negligible impact on their operation.
- 6.77 This 2031 Reference Case + Development scenario has considered all proposed mitigation schemes included within the Reference Case model.
- 6.78 In respect of the proposed site access junction, the priority T-junction with Camp Road is shown to operate well within capacity in both peak hours, with negligible queues and delays.

7.0 Summary and Conclusion

Summary

- 7.1 Hub Transport Planning Ltd has been commissioned by Richborough Estates and Lone Star Land to provide transport advice for a proposed residential development on land north of Camp Road, Heyford Park.
- 7.2 The application is for the erection of up to 230 dwellings, creation of a new vehicular access from Camp Road and all associated works; however, it should be noted that for the purpose of this report, we have considered a development of 250 dwellings to provide a robust assessment of the impacts, but which also allows for potential changes to the future housing density/mix at reserved matter stage.
- 7.3 The site is in a suitable location in transport terms, with existing local facilities located within Heyford Park and many others to be implemented as part of the greater Heyford Park SUE development. These current and planned facilities include retail and employment buildings, medical centre, and new school, as well as others.
- 7.4 All local facilities across Heyford Park are located within a comfortable walking and cycling distance with sustainable transport routes are present; the proposed development will deliver pedestrian and cycle connectivity from Camp Road as well as from Chilgrove Drive.
- 7.5 The site benefits from being near to bus stops on Camp Road, served by a regular bus service for the urban areas of Bicester and Oxford. Heyford Rail Station is also accessible from the site, allowing multi-modal connections to be made onward to national destinations.
- 7.6 A review of PIA data obtained from Oxfordshire County Council indicates that a total of 20 PIAs have occurred with the Heyford Park search area including five along Camp Road through Heyford Park. However, following subsequent analysis of the accidents and causation factors, the volume and pattern of accidents recorded in the area does not give any undue cause for concern.
- 7.7 Safe and suitable access to the site will be provided via a new priority T-junction with Camp Road, with visibility splays are available in line with relevant design guidance to both the east and west of the access junction.
- 7.8 The development is forecast to generate up to 150 two-way vehicle trips during any peak hour, this equates to an additional two to three additional vehicles on the local highway network every minute.
- 7.9 The impact of the proposed development traffic has been assessed across the surrounding highway network using the Bicester SATURN model, as agreed with OCC.
- 7.10 Capacity analysis for the 2031 Reference Case + Development scenario demonstrates that the additional development traffic will not have a material impact across the local highway network; this includes junctions with approved mitigation schemes (agreed as part of the wider Heyford Park development site).
- 7.11 In addition to the above, the proposed development will have a negligible impact on the M40 junctions to the northeast of the site.
- 7.12 A Travel Plan (TP) has also been prepared which sets out measures and initiatives to promote sustainable travel to and from the site.

Conclusion

- 7.13 The National Planning Policy Framework (NPPF) states that opportunities to promote sustainable transport modes should be taken up and that safe and suitable access to the site should be achievable for all users.
- 7.14 The development is located to make use of existing infrastructure and services and is suitable in transport terms; it will promote the use of sustainable modes of transport, and the site provides safe and suitable access for all users.
- 7.15 Bearing the above in mind, the NPPF states that:
- 'Development should only be prevented or refused on highways grounds if there would be an unacceptable impact on highway safety, or the residual cumulative impacts on the road network would be severe.'*
- 7.16 The assessment work undertaken and detailed in this report demonstrates that, in NPPF terms, the development will not have a severe impact on the operation of the local highway network or an unacceptable impact on highway safety.
- 7.17 It is therefore concluded that the proposals accord with national, regional, and local transport related policies and as such, it is considered that there are no reasons why the proposals should be resisted on traffic or transportation grounds.

T19562
Heyford Park



Figures

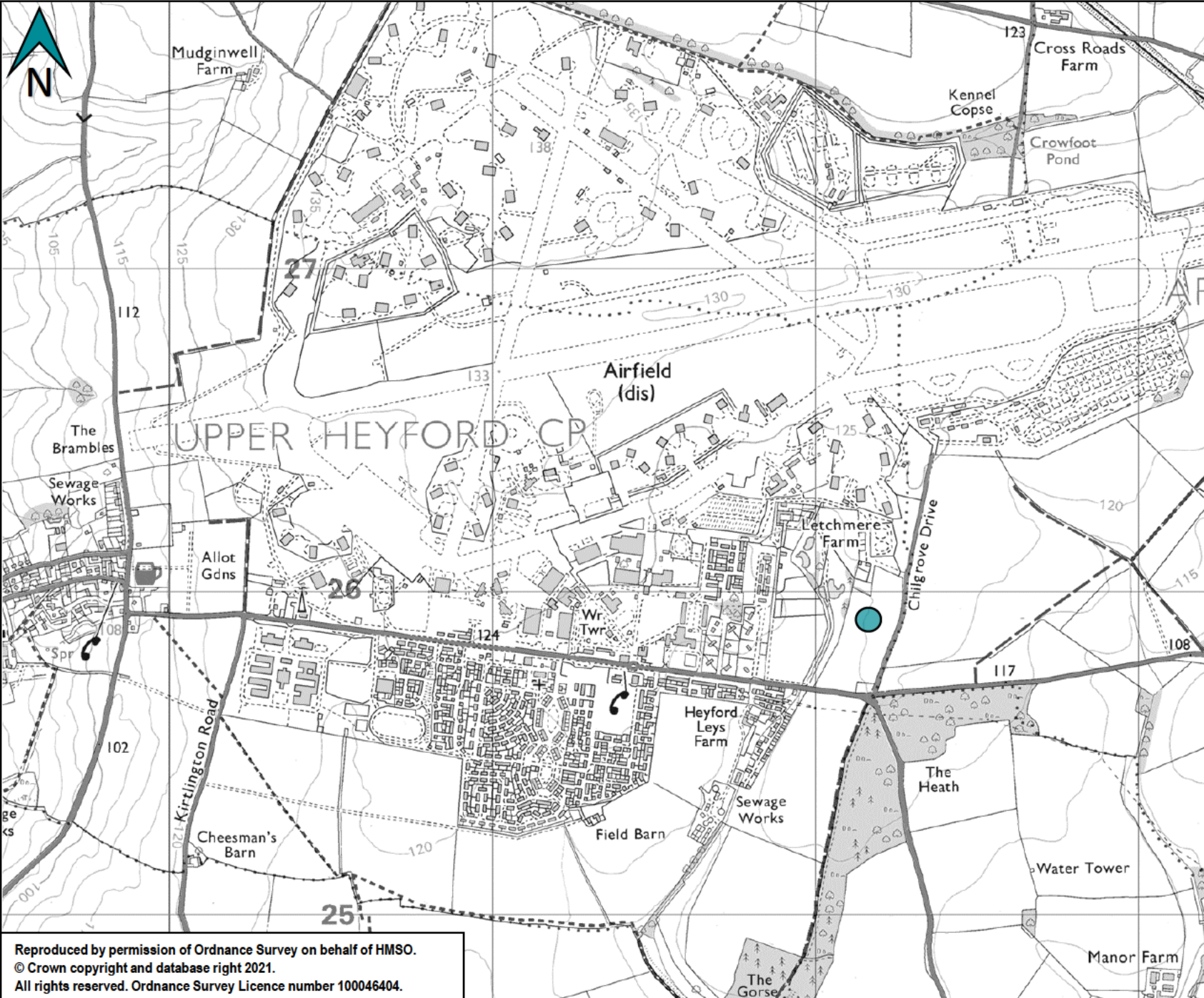

Legend
 Site



Not to Scale
 Heyford Park
Figure 1.1 – Site Location

Reproduced by permission of Ordnance Survey on behalf of HMSO.
 © Crown copyright and database right 2021.
 All rights reserved. Ordnance Survey Licence number 100046404.

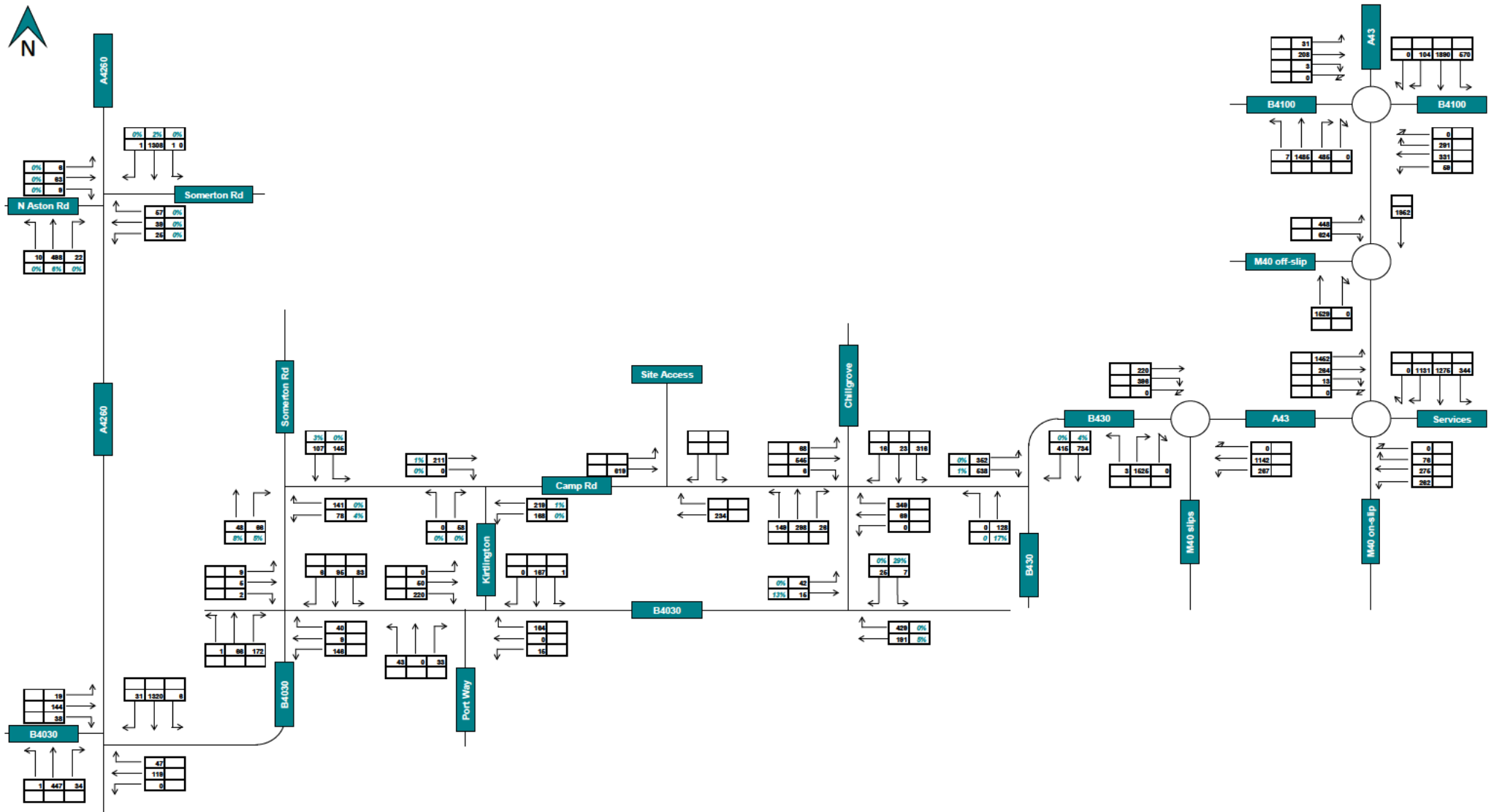

123	PCUs
123	HGV %

	T19562
	Camp Road, Heyford Park
	Figure 3.1
	2031 Reference Case - Northern Junctions AM Peak Hour 08:00 - 09:00

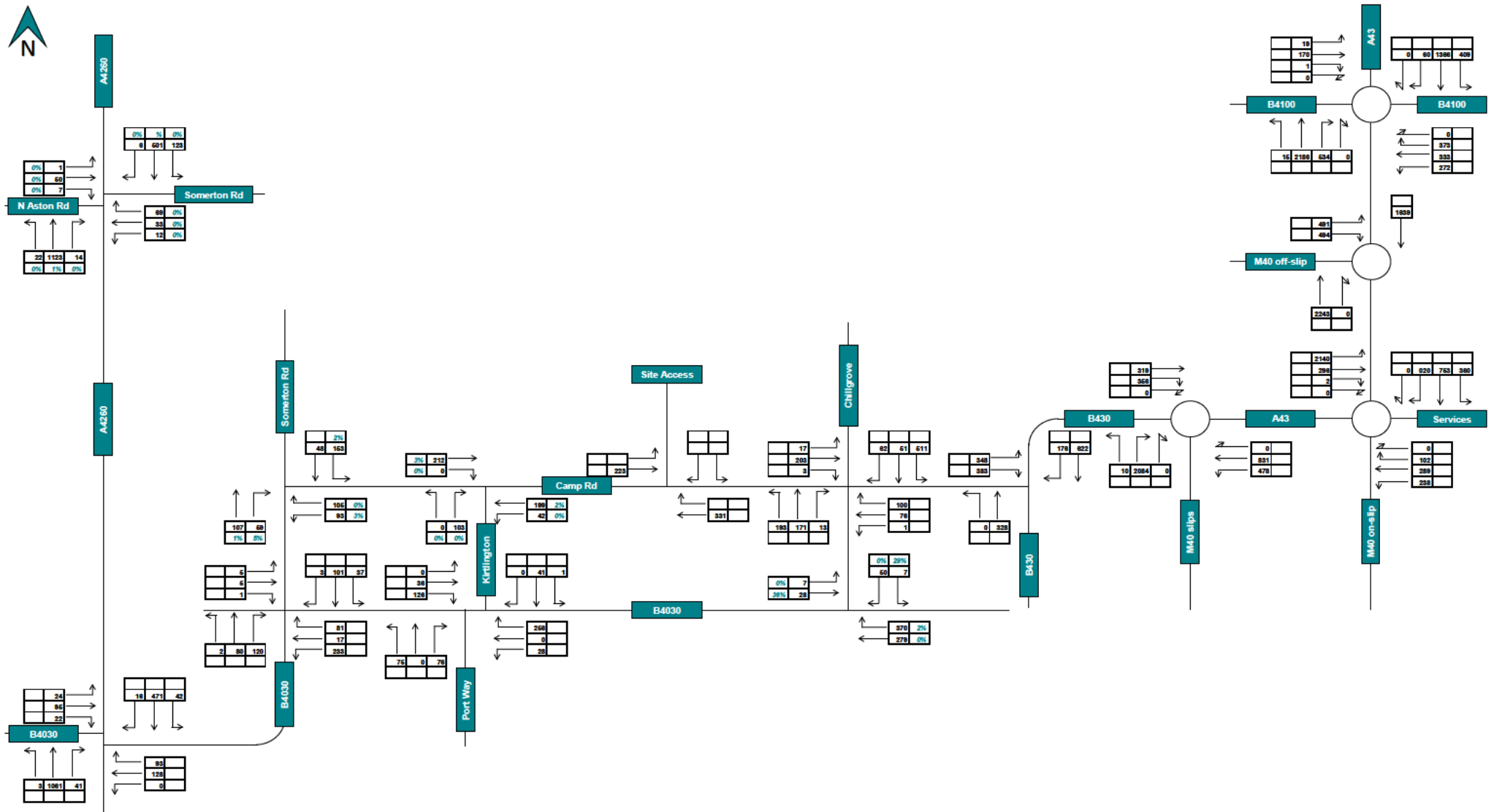

123	PCUs
123	HGV %

 <small>TRANSPORT PLANNING LTD</small>	T19562
	Camp Road, Heyford Park
	Figure 3.2
	2031 Reference Case - Northern Junctions PM Peak Hour 17:00 - 18:00

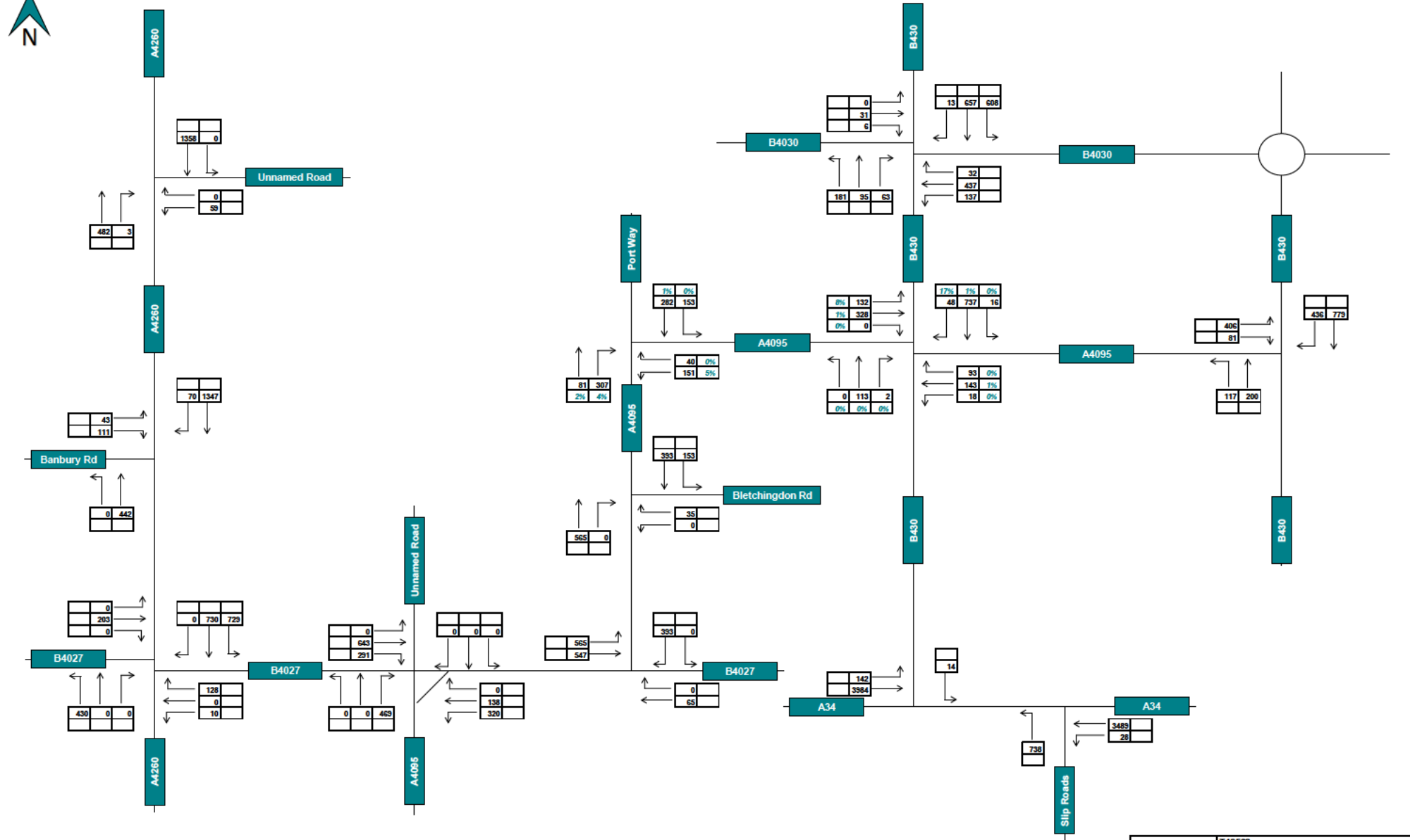

123	PCUs
123	HGV %

T19562
Camp Road, Heyford Park
 Figure 3.3
 2031 Reference Case - Southern Junctions
 AM Peak Hour: 08:00 - 09:00

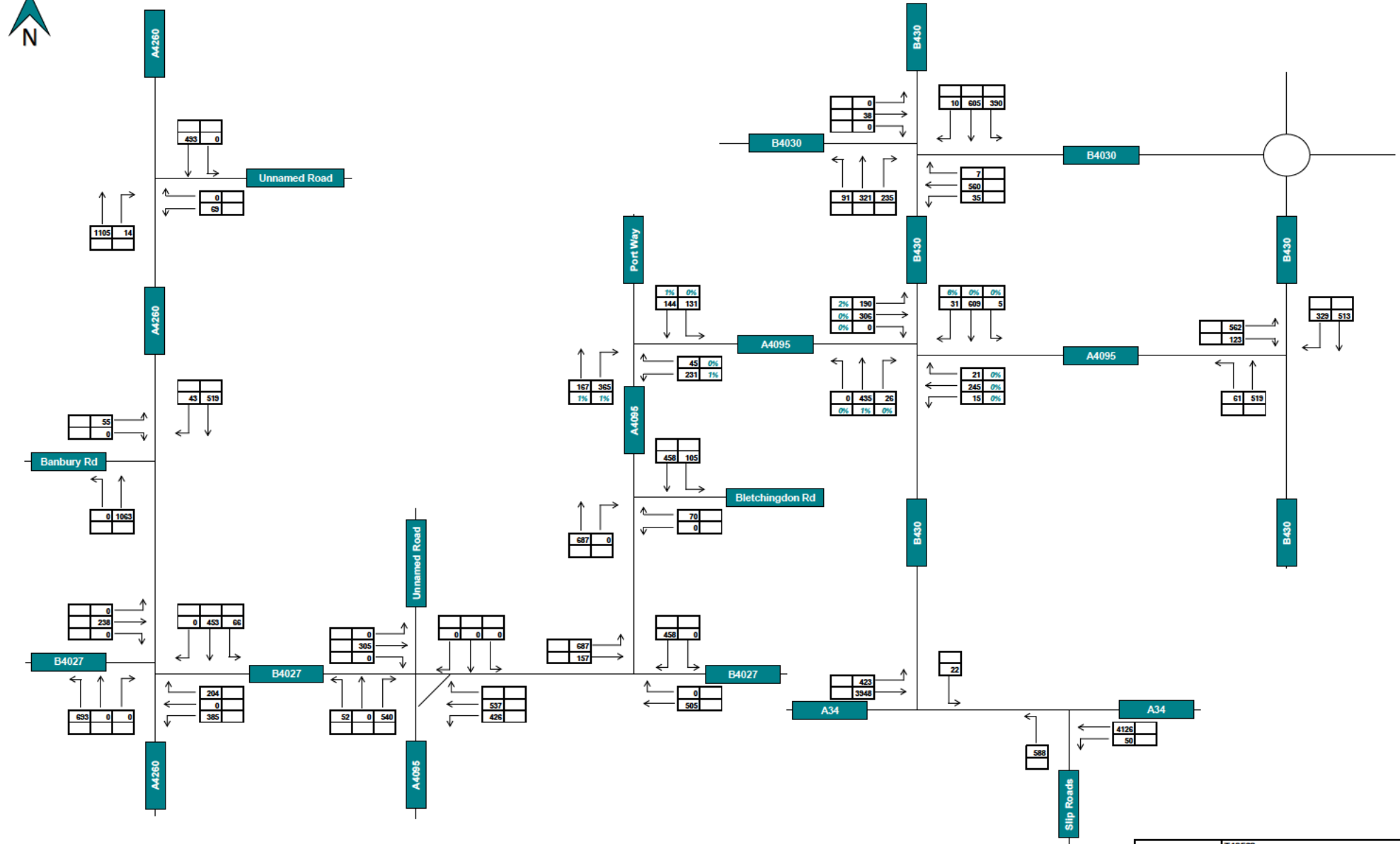

123	PCUs
123	HGV %

T19562
Camp Road, Heyford Park
 Figure 3.4
 2031 Reference Case - Southern Junctions
 PM Peak Hour: 17:00 - 18:00

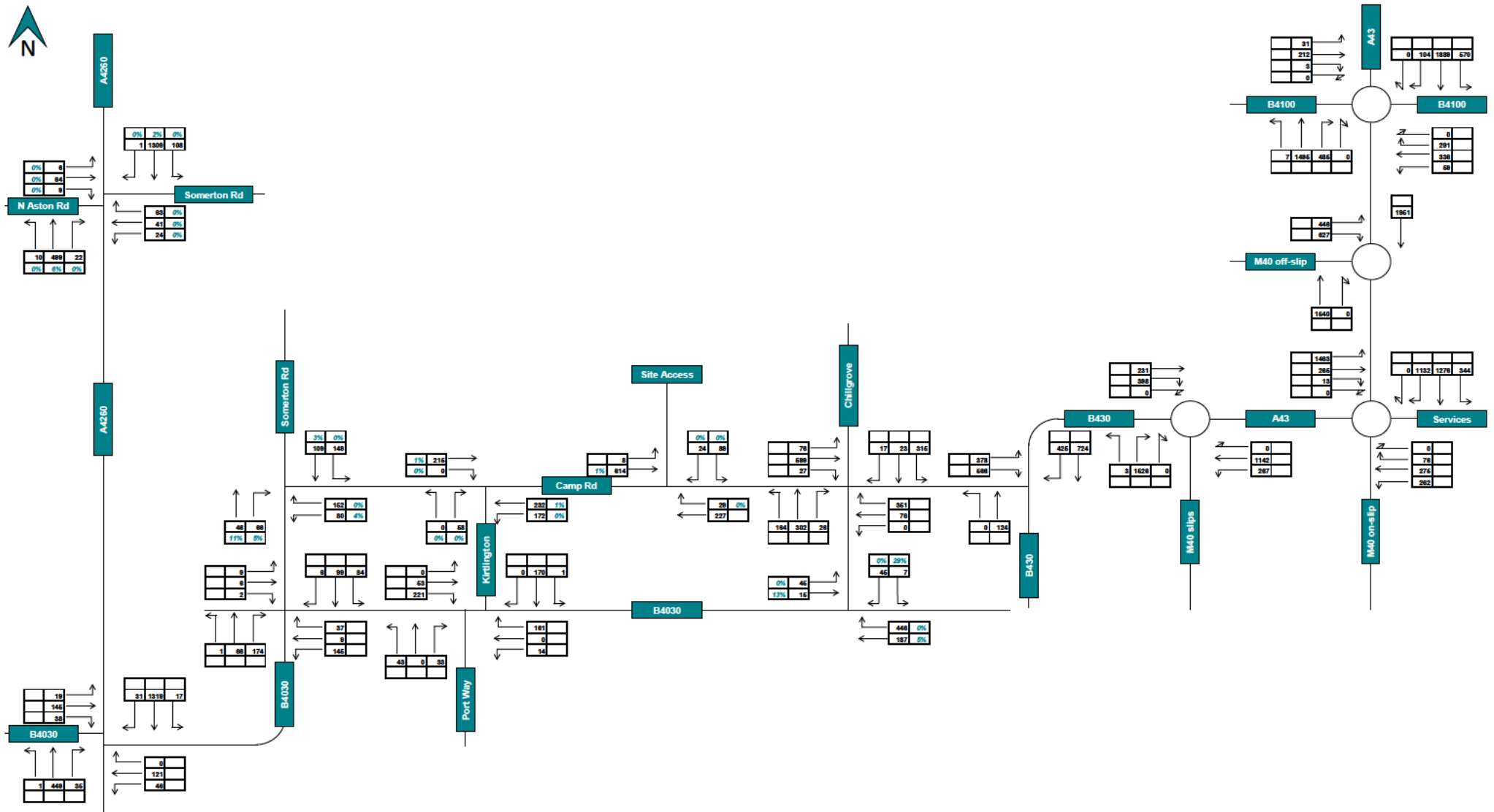

123	PCUs
123	HGV %

	T19562
	Camp Road, Heyford Park
	Figure 3.5
	2031 with Development - Northern Junctions AM Peak Hour 08:00 - 09:00

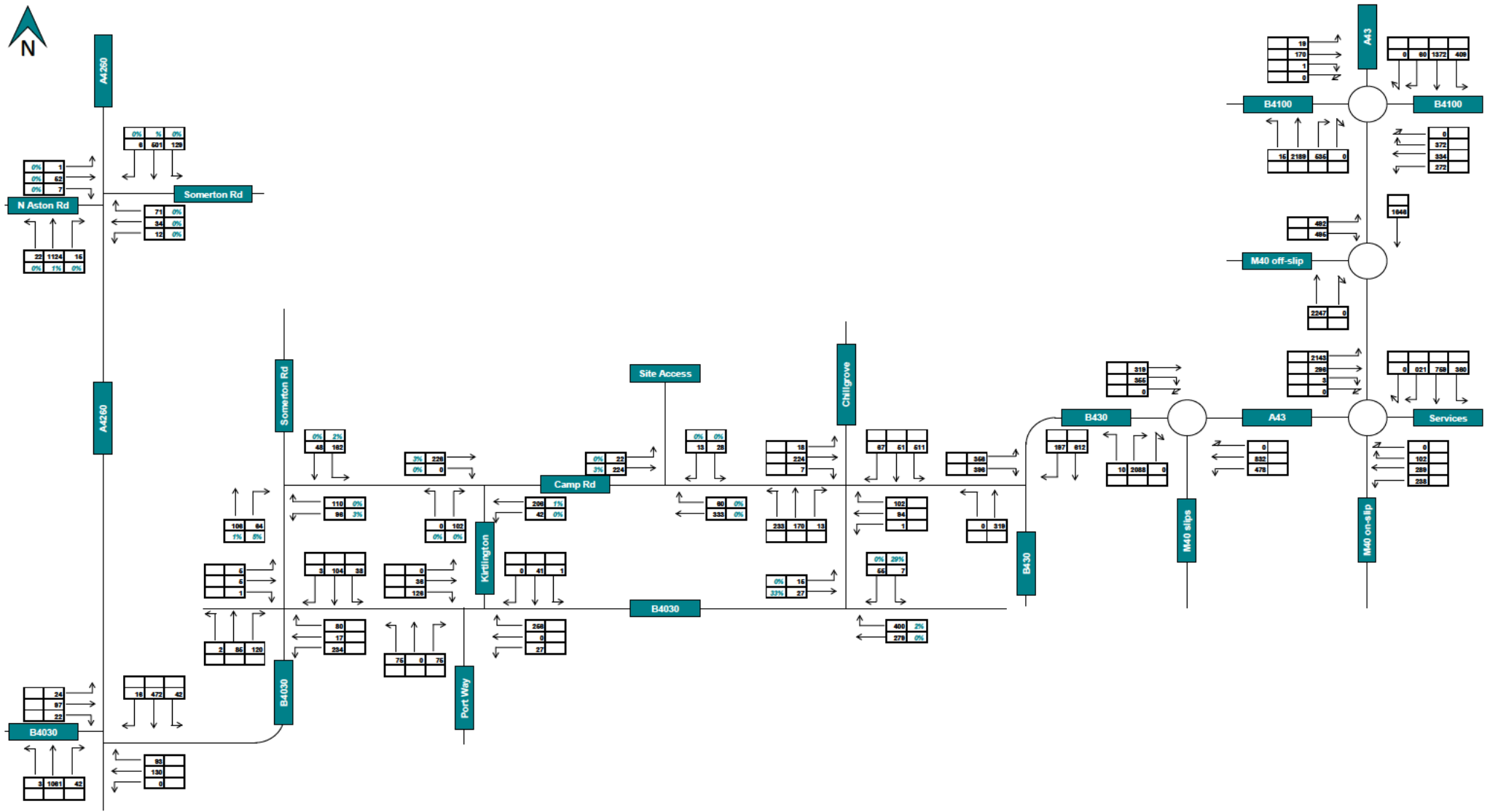

123	PCUs
123	HGV %

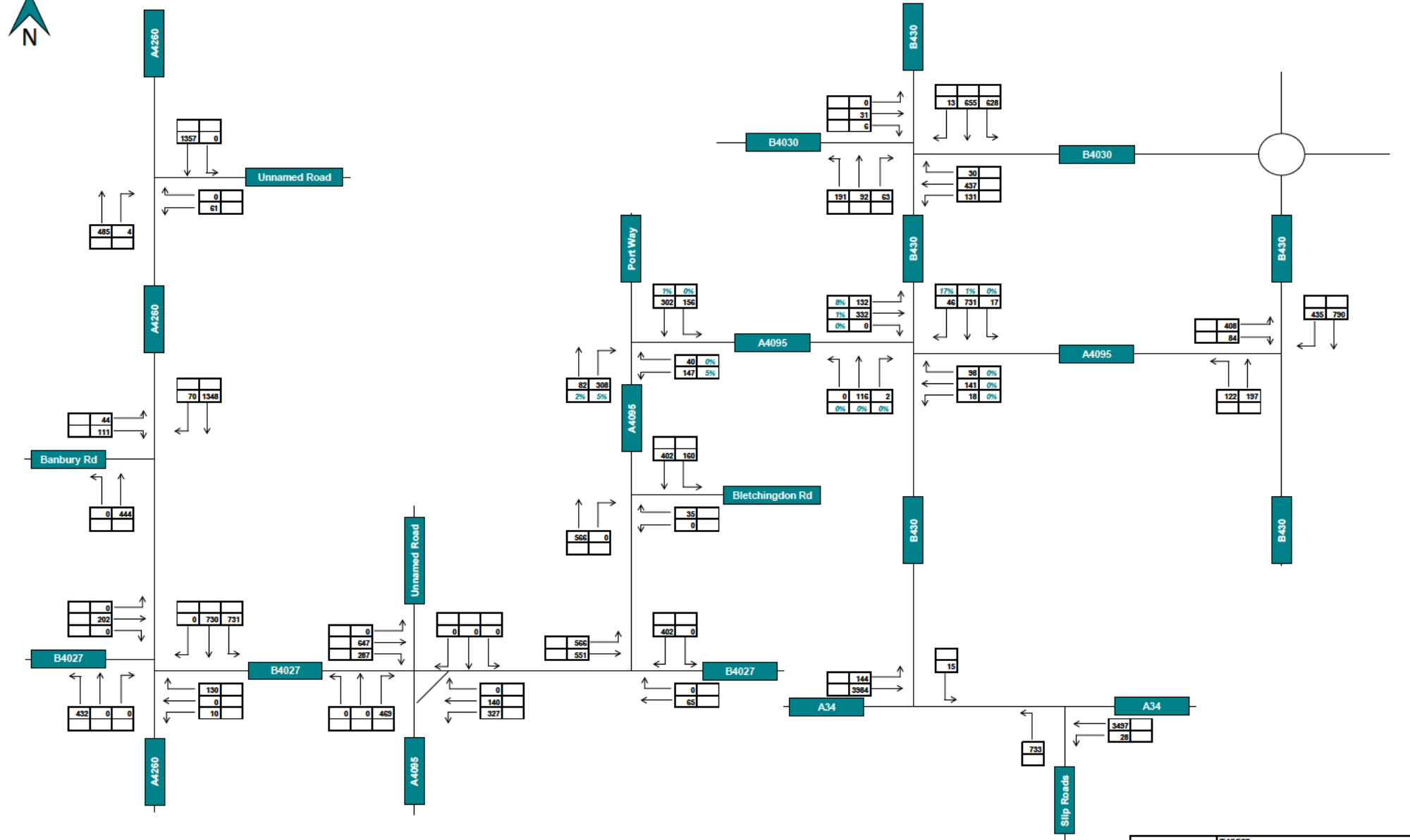

123	PCUs
123	HGV %



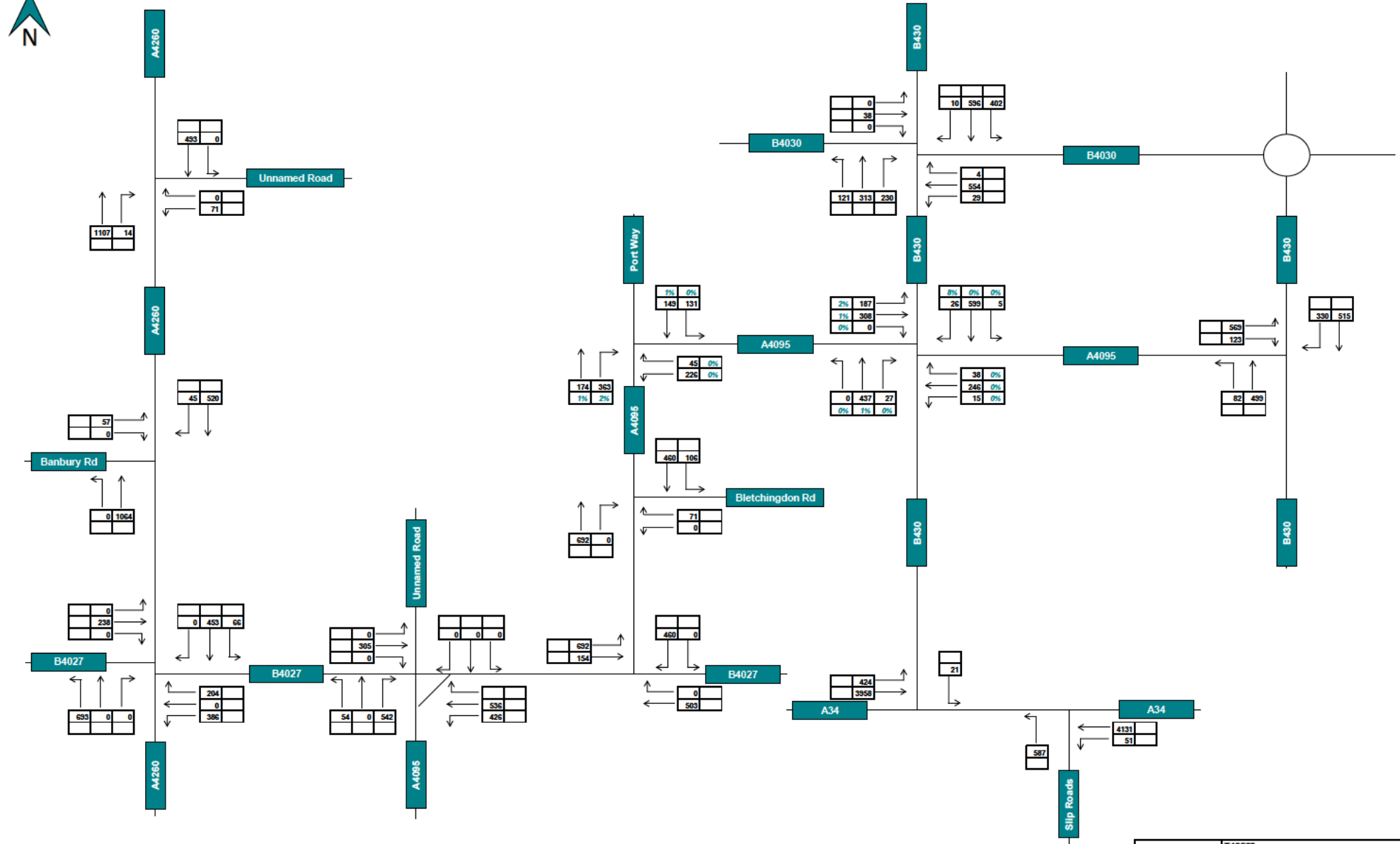





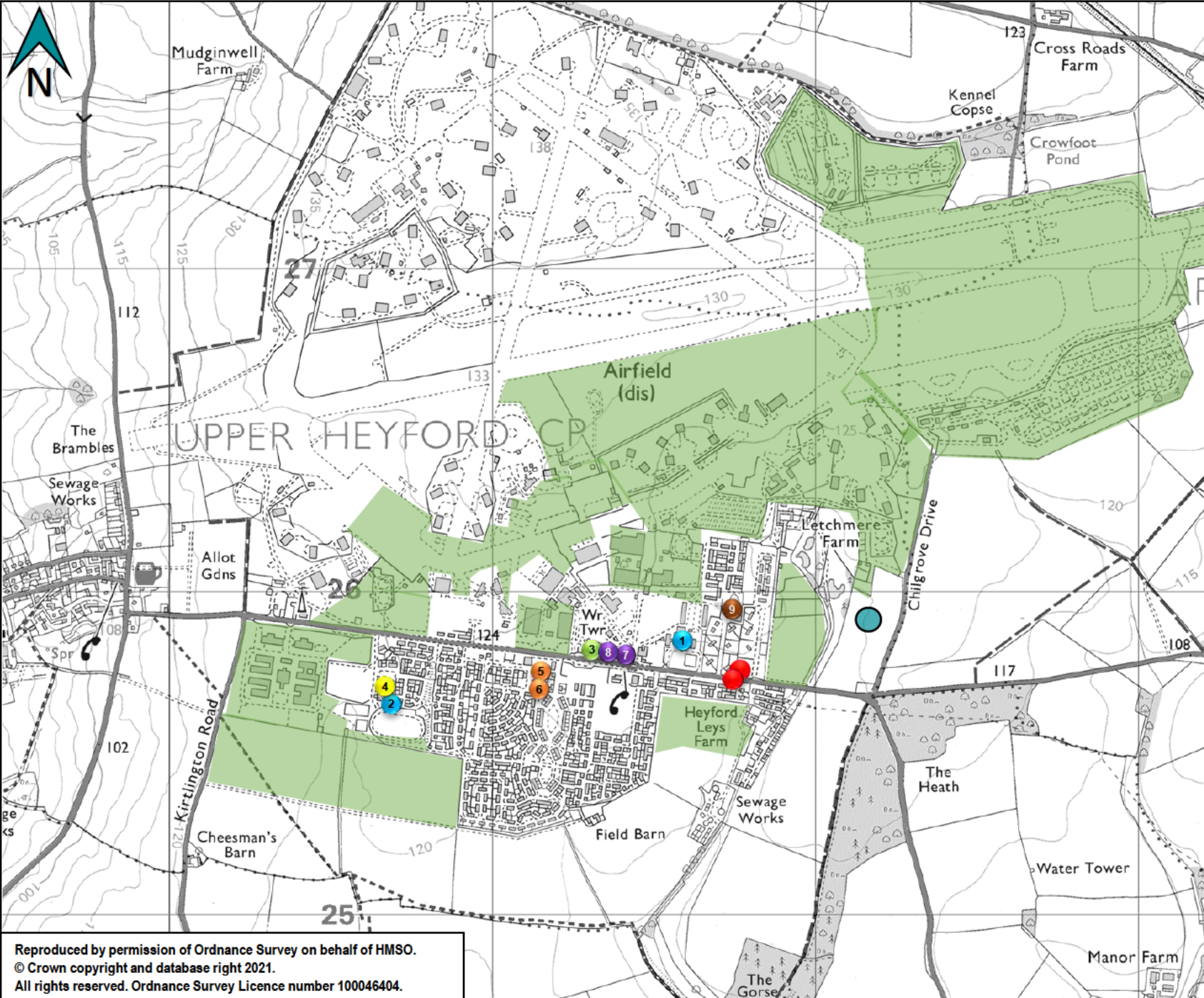



T19562
Camp Road, Heyford Park
 Figure 3.7
 2031 with Development - Southern Junctions
 AM Peak Hour: 08:00 - 09:00



123	PCUs
123	HGV %

T19562
Camp Road, Heyford Park
Figure 3.8
2031 with Development - Southern Junctions
PM Peak Hour: 17:00 - 18:00



- Legend**
-  Site
 -  Heyford Park Employment/Residential Development
 -  Bus Stop
 -  Heyford Park School
 -  Heyford Park Nursery
 -  Heyford Smiles Dental Clinic
 -  Heyford Park Gym
 -  Heyford Park Community Centre/Shop
 -  Heyford Park Chapel
 -  Sainsbury's Local
 -  Heyford Bike Service & Repair/Spokes Coffee
 -  Heyford Park Innovation Centre



Reproduced by permission of Ordnance Survey on behalf of HMSO.
 © Crown copyright and database right 2021.
 All rights reserved. Ordnance Survey Licence number 100046404.

Not to Scale
 Heyford Park
Figure 3.9 – Local Facilities

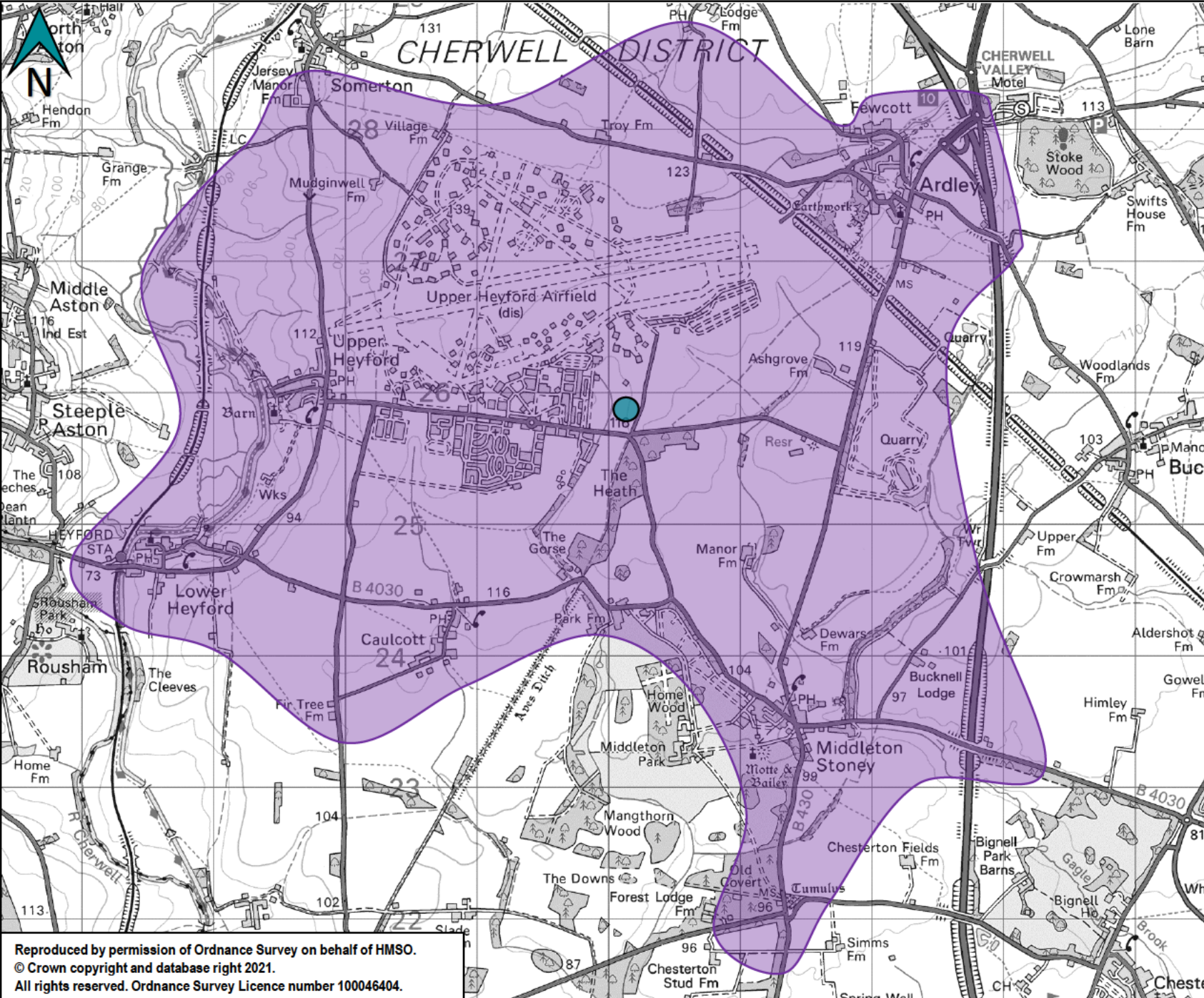

Legend

- Site
- 5.0km Cycle Distance

Reproduced by permission of Ordnance Survey on behalf of HMSO.
 © Crown copyright and database right 2021.
 All rights reserved. Ordnance Survey Licence number 100046404.



Not to Scale
 Heyford Park
 Figure 3.11 – Cycle Distance

T19562
Heyford Park



Drawings

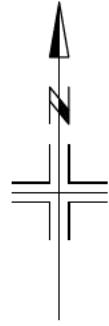

NEW FOOTWAY TO CONNECT TO PROPOSED BUS STOP ADJACENT TO PYE HOMES DEVELOPMENT

WHERE REQUIRED, EXISTING HEDGEROW TO BE REPLACED BY NEW SPECIES RICH HEDGEROW BEHIND 2.4M X 59M VISIBILITY SPLAYS

CARRIAGEWAY AND FOOTWAY TO TIE INTO PROPOSED TRAFFIC-CALMING SCHEME (ZEBRA CROSSING TO BE MOVED 6.0M EAST)

CARRIAGEWAY AND SHARED FOOTWAY/CYCLEWAY TO TIE INTO PROPOSED SIGNALS SCHEME AT CHILGROVE DRIVE WITH MINOR FLARE INCREASE

1:1250

1. THIS DRAWING IS NOT TO BE SCALED FOR CONSTRUCTION PURPOSES.
2. THE CONTRACTOR SHALL CHECK ALL DIMENSIONS AND LEVELS ON SITE.

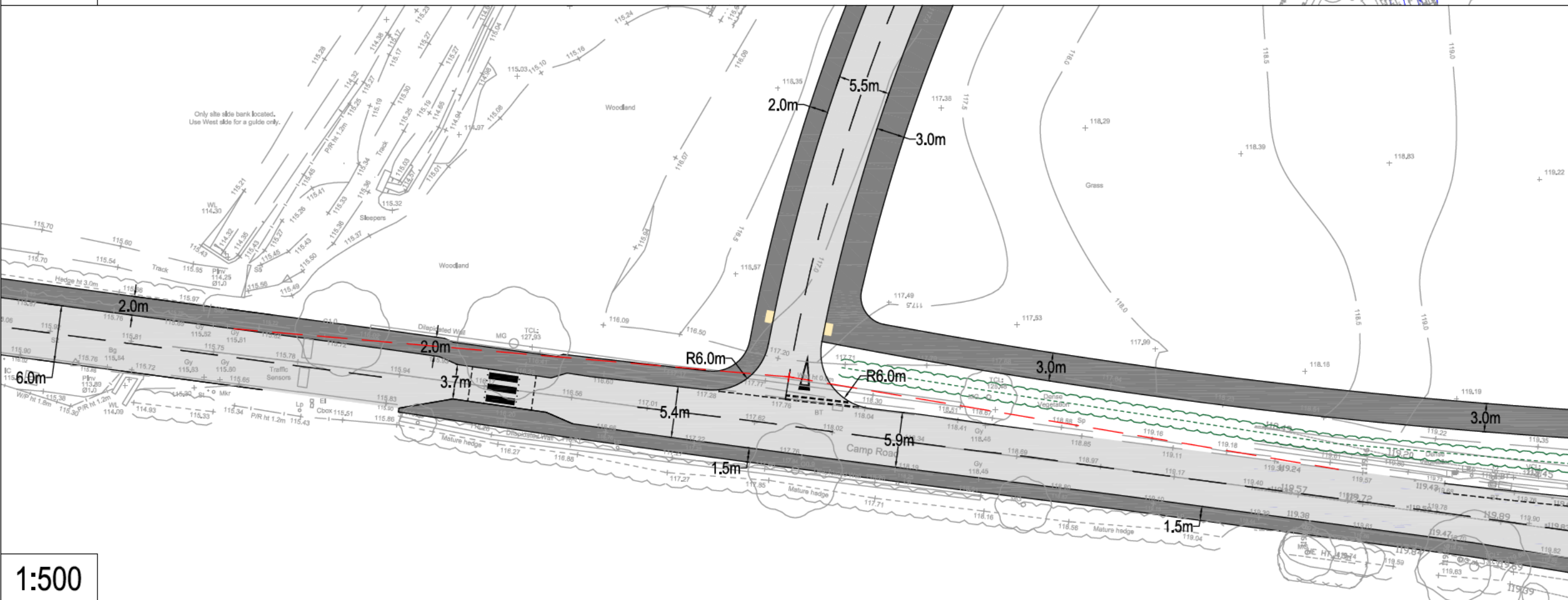

1:500

A	MINOR JUNCTION AMENDMENTS	15.12.21	JP	GM
REV	DESCRIPTION	DATE	BY	AUTH



Hub Transport Planning Ltd
Radclyffe House
66/68 Hagley Road
Edgbaston
Birmingham
West Midlands
B16 8PF
T: 0121 454 5530

CLIENT
RICHBOROUGH ESTATES & LONE STAR LAND

PROJECT
HEYFORD PARK

TITLE
SITE ACCESS JUNCTION WITH VISIBILITY SPLAYS AND CROSSING

DRAWN	AUTHORISED	SCALE	SHEET SIZE	DATE
JP	GM	AS SHOWN	A3	25.10.21

PROJECT NO.	DRAWING NO.	REV
T19562	001	A

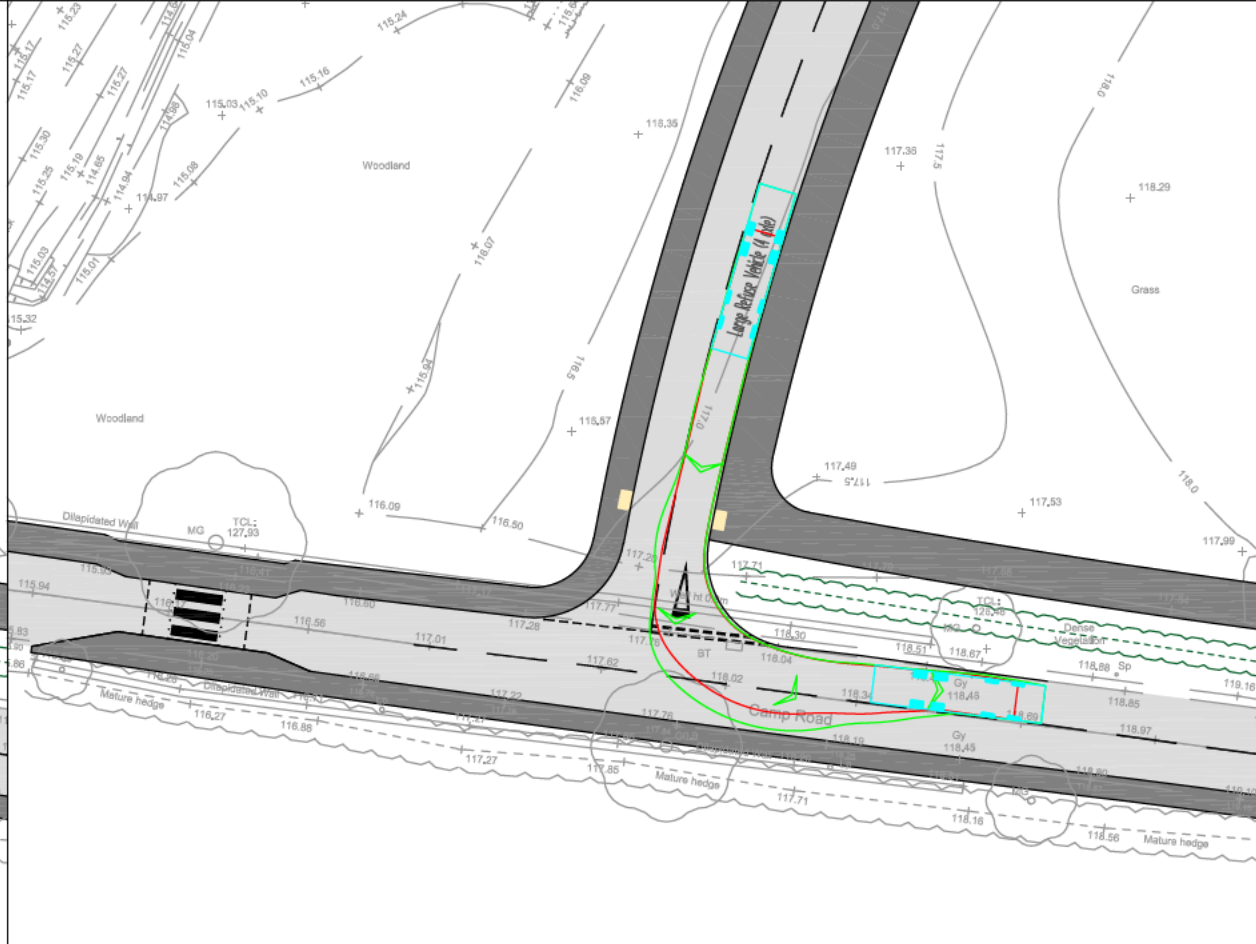
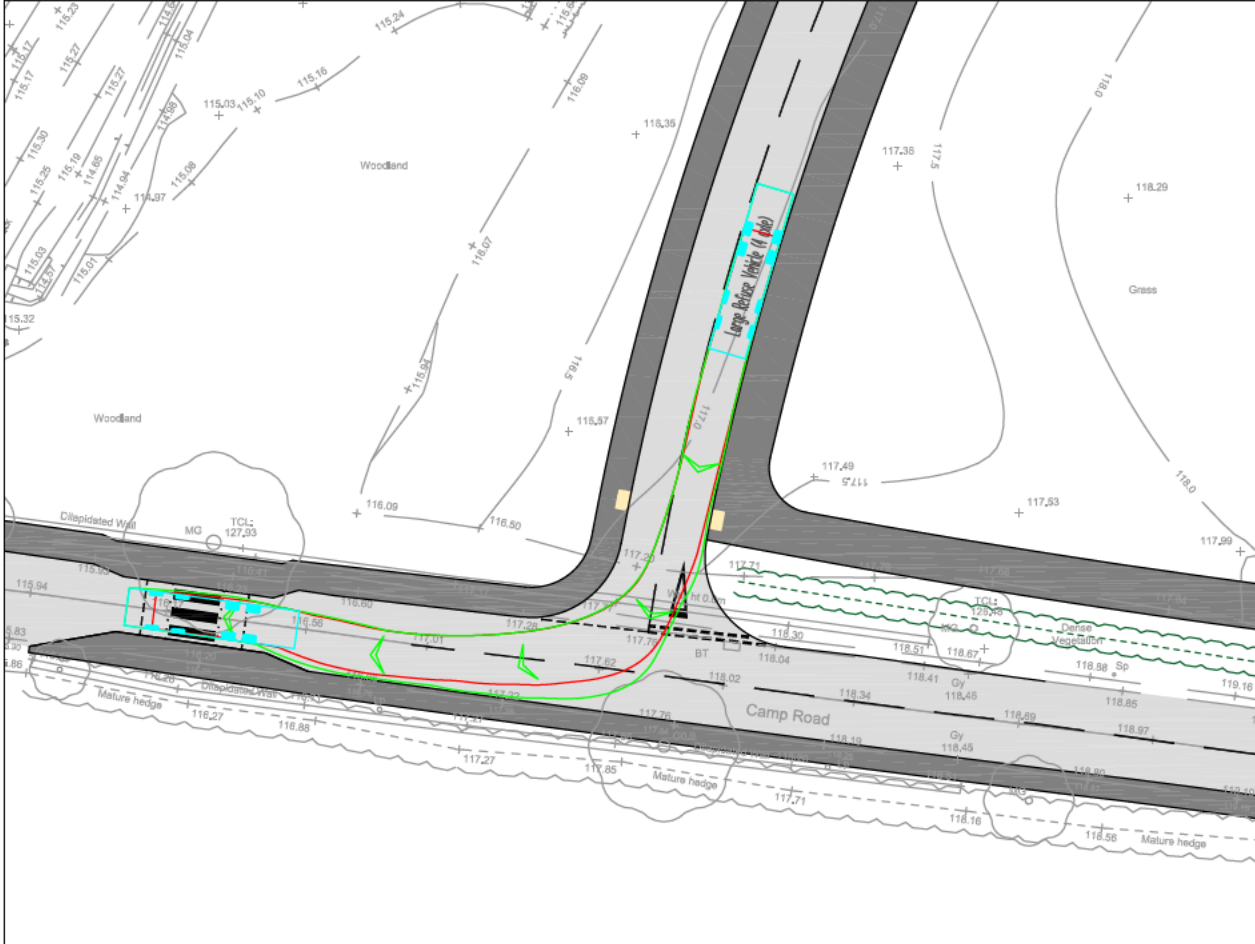
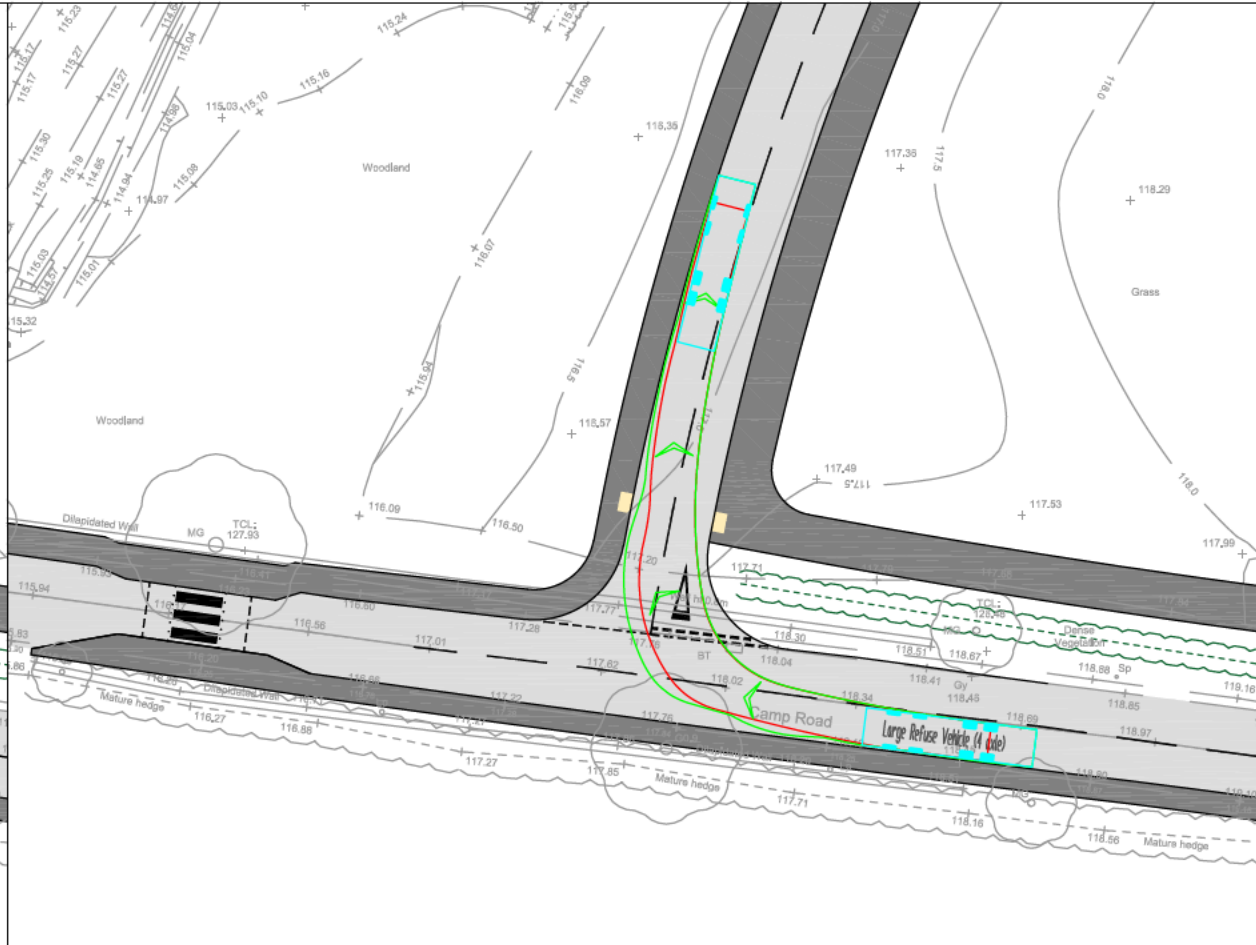
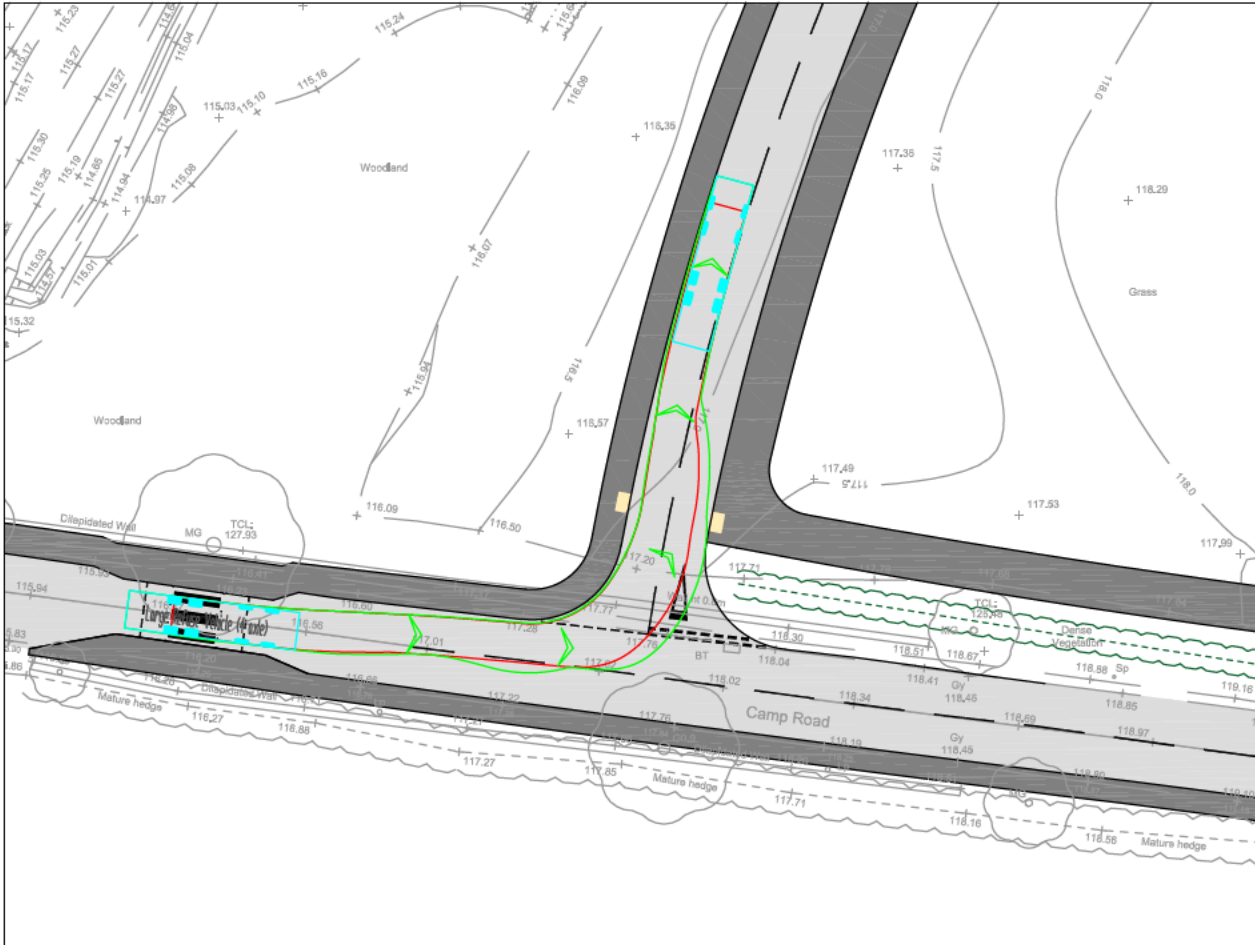

1. THIS DRAWING IS NOT TO BE SCALED FOR CONSTRUCTION PURPOSES.
2. THE CONTRACTOR SHALL CHECK ALL DIMENSIONS AND LEVELS ON SITE.

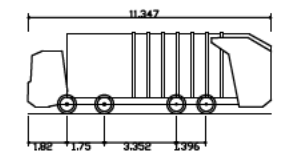

Large Refuse Vehicle (4 axle)
 Overall Length 11.347m
 Overall Width 3.352m
 Overall Body Height 3.751m
 Min Body Ground Clearance 0.304m
 Track Width 2.500m
 Lock to lock time 6.00s
 Wall to Wall Turning Radius 11.350m

REV	DESCRIPTION	DATE	BY	AUTH
-----	-------------	------	----	------



Hub Transport Planning Ltd
 Raddlyffe House
 66/68 Hagley Road
 Edgbaston
 Birmingham
 West Midlands
 B16 8PF
 T : 0121 454 5530

CLIENT
RICHBOROUGH ESTATES & LONE STAR LAND

PROJECT
HEYFORD PARK

TITLE
**SITE ACCESS JUNCTION
 SWEEP PATH ANALYSIS 01**

DRAWN JP	AUTHORISED GM	SCALE 1:500	SHEET SIZE A3	DATE 25.10.21
PROJECT NO. T19562		DRAWING NO. 002		REV -

T19562
Heyford Park



Appendix A

Traffic Modelling Data (Bicester SATURN Model)

A099211-05 Bicester Transport Model
2031_Upper_Heyford_Park_RC_TurningMovements.xlsx

Summary of Spreadsheet

Uses model text file dumps and cordon matrices to produce turning movements for junctions of interest.

Original Author Sacha Pearson

Summary of Worksheets

Sheet Name	Brief Explanation
Jn_Locations	Shows location and reference of each junction
Turning_Movements	Single Node Junctions: Turning movements identified by three nodes, with the corresponding demand turning flow then read from the raw data outputted from Saturn. Complex Junctions: Cordon matrices created and data output using MX. Note: Where turning movements are calculated using the cordon matrices, bus flows have been added manually.

Insert more rows as required...

Check log

Date	Initials	Description
27/10/2021	SP	Spreadsheet created.
27/10/2021	SP	Data extracted from model.
28/10/2021	SP	Spreadsheet populated with turning movements.
28/10/2021	SP	Turning movement data checked against P1X.
05/11/2021	SP	Camp Road / Chilgrove Drive (Junction 25) data added and checked

Insert more rows as required...

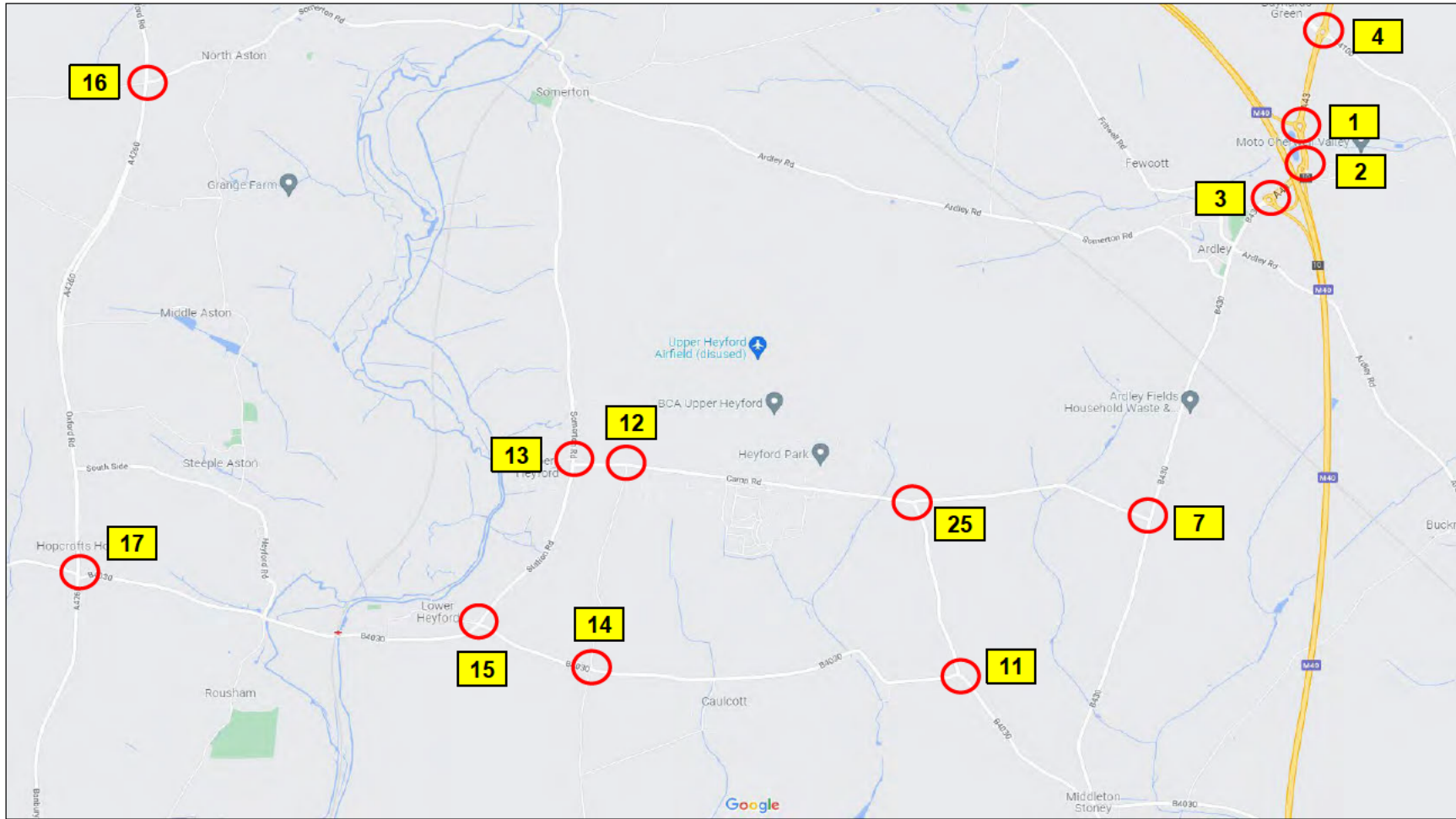

1	M40 Junction 10 (Padbury junction)
2	M40 Junction 10 (Cherwell junction)
3	M40 Junction 10 (Arley junction)
4	A43 / B4100 (Baynards Green) roundabout
5	A34 Northbound Slip Roads / B430 junction
6	A34 Southbound Slip Roads / B430 junction
7	B430 / Unnamed Road junction
8	B430 / B4030 (Middletton Stoney) junction

9	A4095 / B430 junction
10	A4095 / B4030 junction
11	B4030 / Unnamed Road junction
12	Camp Road / Kirklington Road junction
13	Camp Road / Somerton Road junction
14	B4030 / Port Way junction
15	B4030 / Station Road junction
16	A4260 / Somerton Road junction

17	A4260 / B4030 (Hopcrofts Holt) junction
18	A4260 / Unnamed Road junction
19	A4260 / Banbury Road / Unnamed Road junction
20	A4260 / B4027 junction
21	A4095 / Portway junction
22	A4095 / Bletchington Road junction
23	A4095 / B4027 junction
24	A4095 / B4027 junction
25	Camp Road / Chilgrove Drive ssignal junction

Junction Location Plan (Sheet 1)

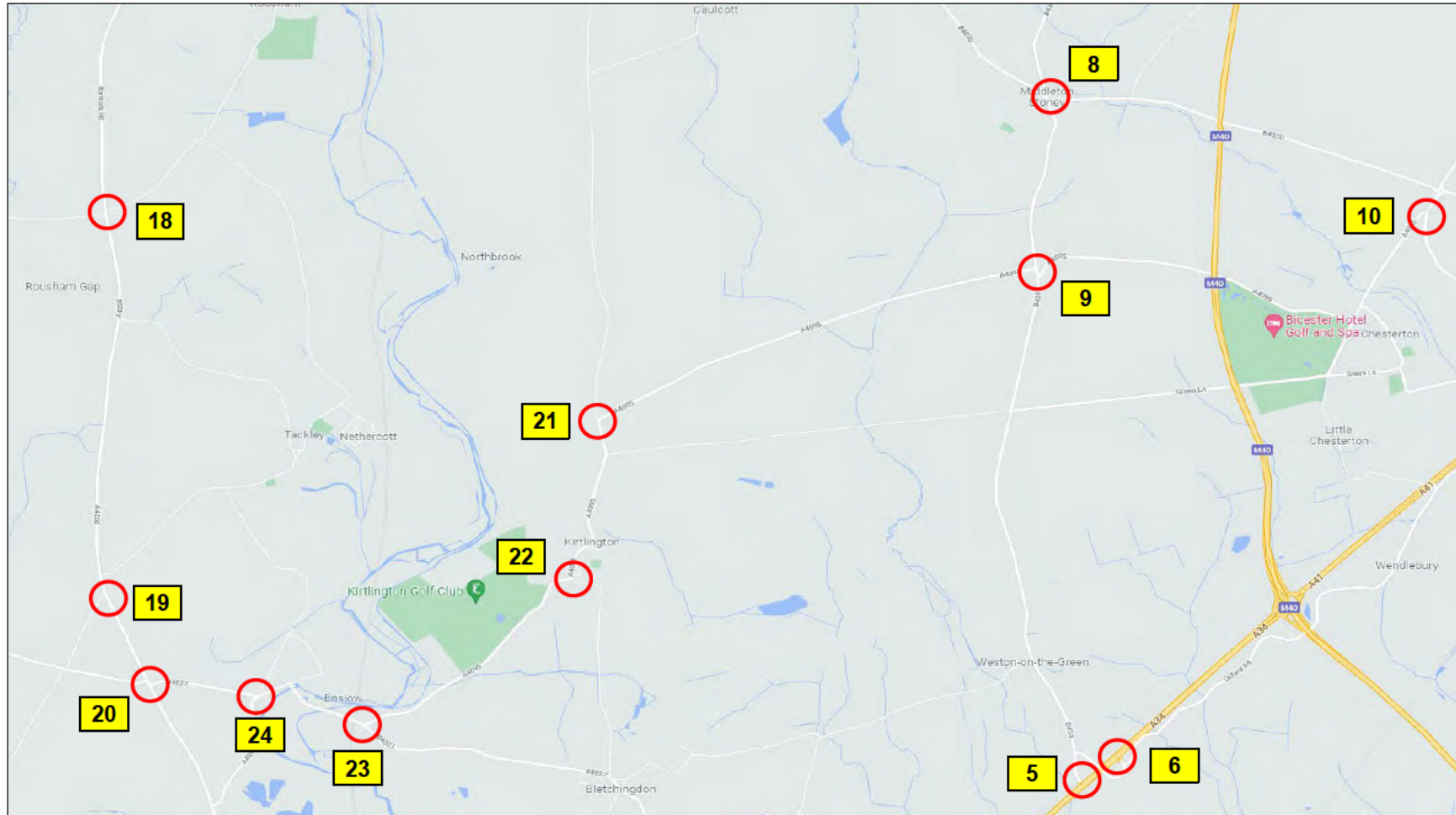

1	M40 Junction 10 (Padbury junction)
2	M40 Junction 10 (Cherwell junction)
3	M40 Junction 10 (Ardley junction)
4	A43 / B4100 (Baynards Green) roundabout
5	A34 Northbound Slip Roads / B430 junction
6	A34 Southbound Slip Roads / B430 junction
7	B430 / Unnamed Road junction
8	B430 / B4030 (Middleton Stony) junction

9	A4095 / B430 junction
10	A4095 / B4030 (Vendee Drive) junction
11	B4030 / Unnamed Road junction
12	Camp Road / Kirtlington Road junction
13	Camp Road / Somerton Road junction
14	B4030 / Port Way junction
15	B4030 / Station Road junction
16	A4260 / Somerton Road junction

17	A4260 / B4030 (Hopcrofts Holt) junction
18	A4260 / Unnamed Road junction
19	A4260 / Banbury Road / Unnamed Road junction
20	A4260 / B4027 junction
21	A4095 / Portway junction
22	A4095 / Bletchington Road junction
23	A4095 / B4027 junction
24	A4095 / B4027 junction
25	Camp Road / Chilgrove Drive signal junction

Junction Location Plan (Sheet 2)

A099211-05 Bicester Transport Model
2031_Upper_Heyford_Park_with_Development_TurningMovements.xlsx

Summary of Spreadsheet

Uses model text file dumps and cordon matrices to produce turning movements for junctions of interest.

Original Author Sacha Pearson

Summary of Worksheets

Sheet Name	Brief Explanation
Jn_Locations	Shows location and reference of each junction
Turning_Movements	Single Node Junctions: Turning movements identified by three nodes, with the corresponding demand turning flow then read from the raw data outputted from Saturn. Complex Junctions: Cordon matrices created and data output using MX. Note: Where turning movements are calculated using the cordon matrices, bus flows have been added manually.

Insert more rows as required...

Check log

Date	Initials	Description
04/11/2021	SP	Spreadsheet created.
05/11/2021	SP	Data extracted from model.
05/11/2021	SP	Spreadsheet populated with turning movements.
06/11/2021	SP	Turning movement data checked against P1X.

Insert more rows as required...



1	M40 Junction 10 (Padbury junction)
2	M40 Junction 10 (Cherwell junction)
3	M40 Junction 10 (Ardley junction)
4	A43 / B4100 (Baynards Green) roundabout
5	A34 Northbound Slip Roads / B430 junction
6	A34 Southbound Slip Roads / B430 junction
7	B430 / Unnamed Road junction
8	B430 / B4030 (Middletton Stoney) junction

9	A4095 / B430 junction
10	A4095 / B4030 junction
11	B4030 / Unnamed Road junction
12	Camp Road / Kirklington Road junction
13	Camp Road / Somerton Road junction
14	B4030 / Port Way junction
15	B4030 / Station Road junction
16	A4260 / Somerton Road junction
17	A4260 / B4030 (Hopcrofts Holt) junction

18	A4260 / Unnamed Road junction
19	A4260 / Banbury Road / Unnamed Road junction
20	A4260 / B4027 junction
21	A4095 / Portway junction
22	A4095 / Bletchington Road junction
23	A4095 / B4027 junction
24	A4095 / B4027 junction
25	Camp Road / Chilgrove Drive signal junction
26	Site Access / Camp Road priority junction

Junction Location Plan (Sheet 1)

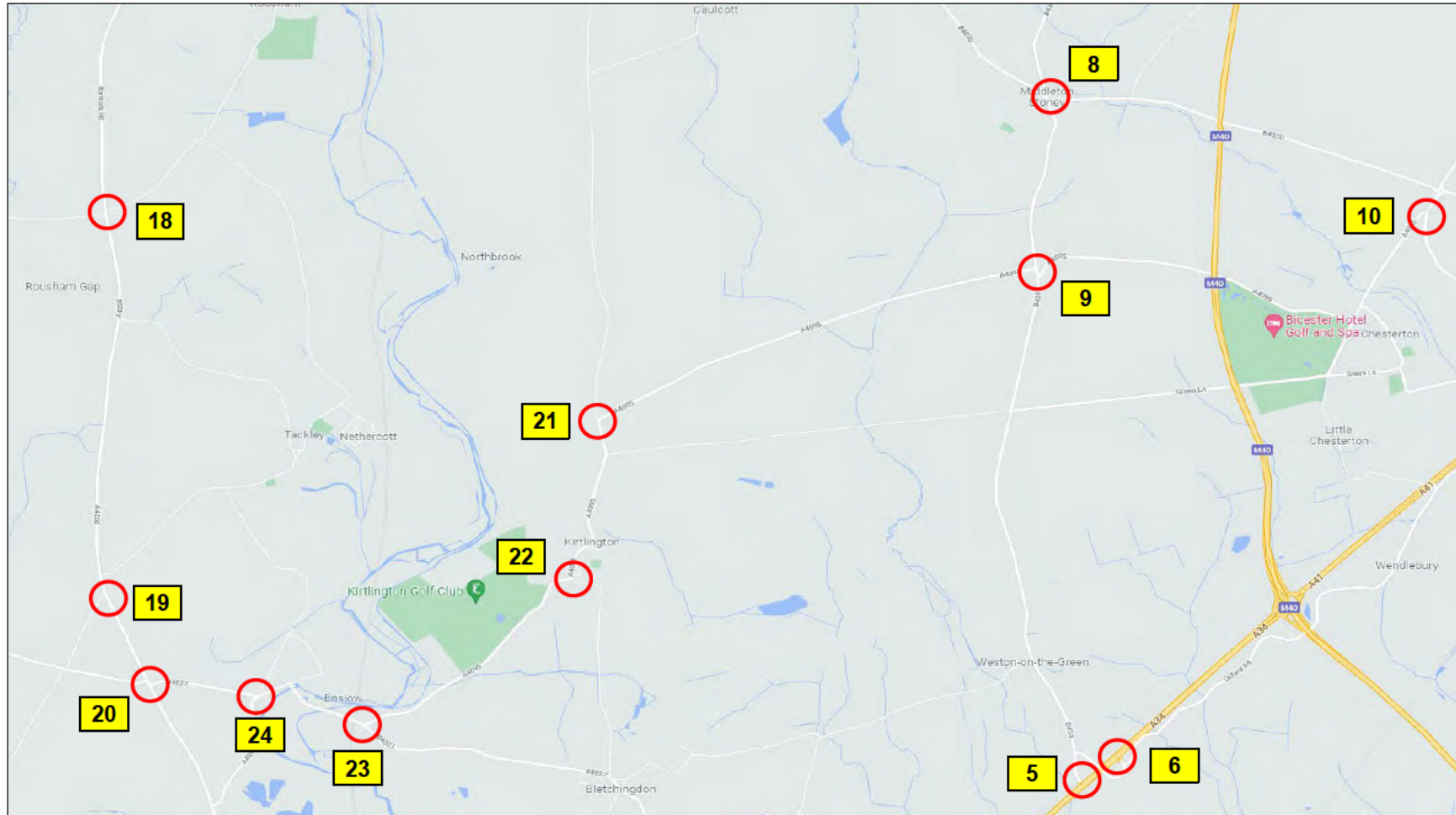

1	M40 Junction 10 (Padbury junction)
2	M40 Junction 10 (Cherwell junction)
3	M40 Junction 10 (Ardley junction)
4	A43 / B4100 (Baynards Green) roundabout
5	A34 Northbound Slip Roads / B430 junction
6	A34 Southbound Slip Roads / B430 junction
7	B430 / Unnamed Road junction
8	B430 / B4030 (Middleton Stoney) junction

9	A4095 / B430 junction
10	A4095 / B4030 (Vendee Drive) junction
11	B4030 / Unnamed Road junction
12	Camp Road / Kirklington Road junction
13	Camp Road / Somerton Road junction
14	B4030 / Port Way junction
15	B4030 / Station Road junction
16	A4260 / Somerton Road junction
17	A4260 / B4030 (Hopcrofts Holt) junction

18	A4260 / Unnamed Road junction
19	A4260 / Banbury Road / Unnamed Road junction
20	A4260 / B4027 junction
21	A4095 / Portway junction
22	A4095 / Bletchington Road junction
23	A4095 / B4027 junction
24	A4095 / B4027 junction
25	Camp Road / Chilgrove Drive signal junction
26	Site Access / Camp Road priority junction

Junction Location Plan (Sheet 2)

T19562
Heyford Park



Appendix B

OCC Accident Data

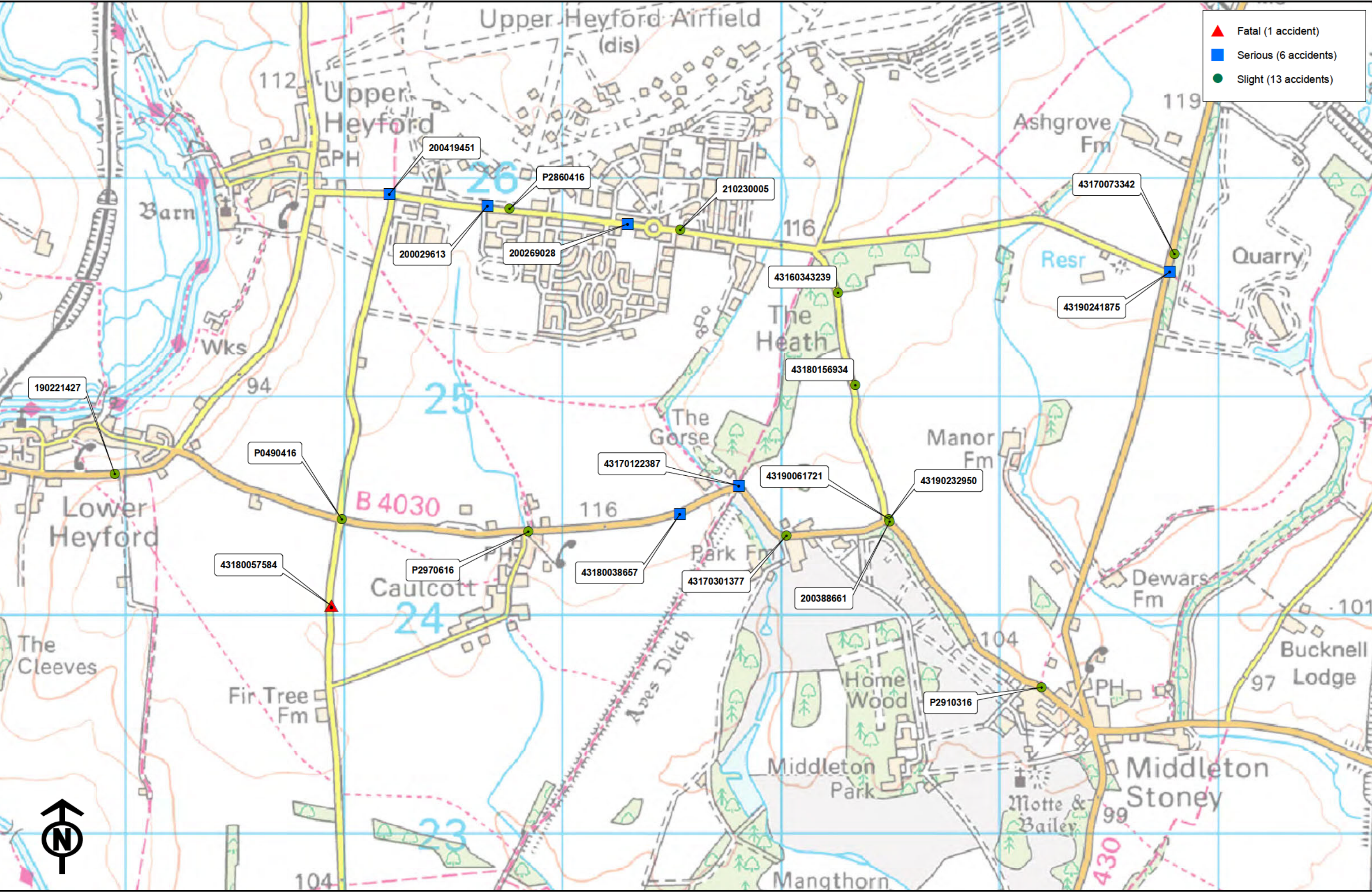



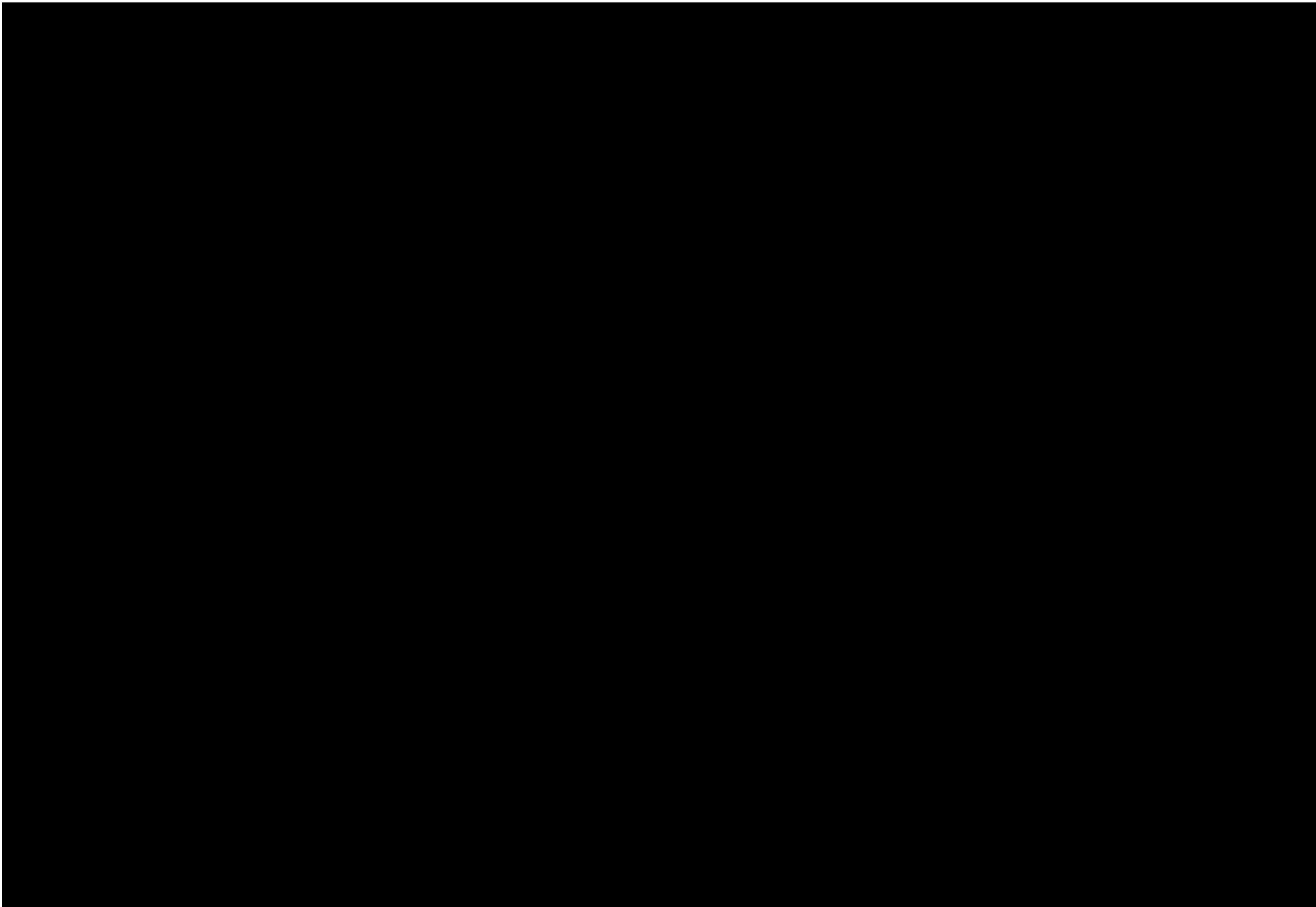

[REDACTED]

[REDACTED]

[REDACTED]

[REDACTED]

[REDACTED]

[REDACTED]

[REDACTED]

[REDACTED]

[REDACTED]

[REDACTED]

[REDACTED]

[REDACTED]

[REDACTED]

[REDACTED]

[REDACTED]

[REDACTED]

[REDACTED]

[REDACTED]

[REDACTED]

[REDACTED]

[REDACTED]

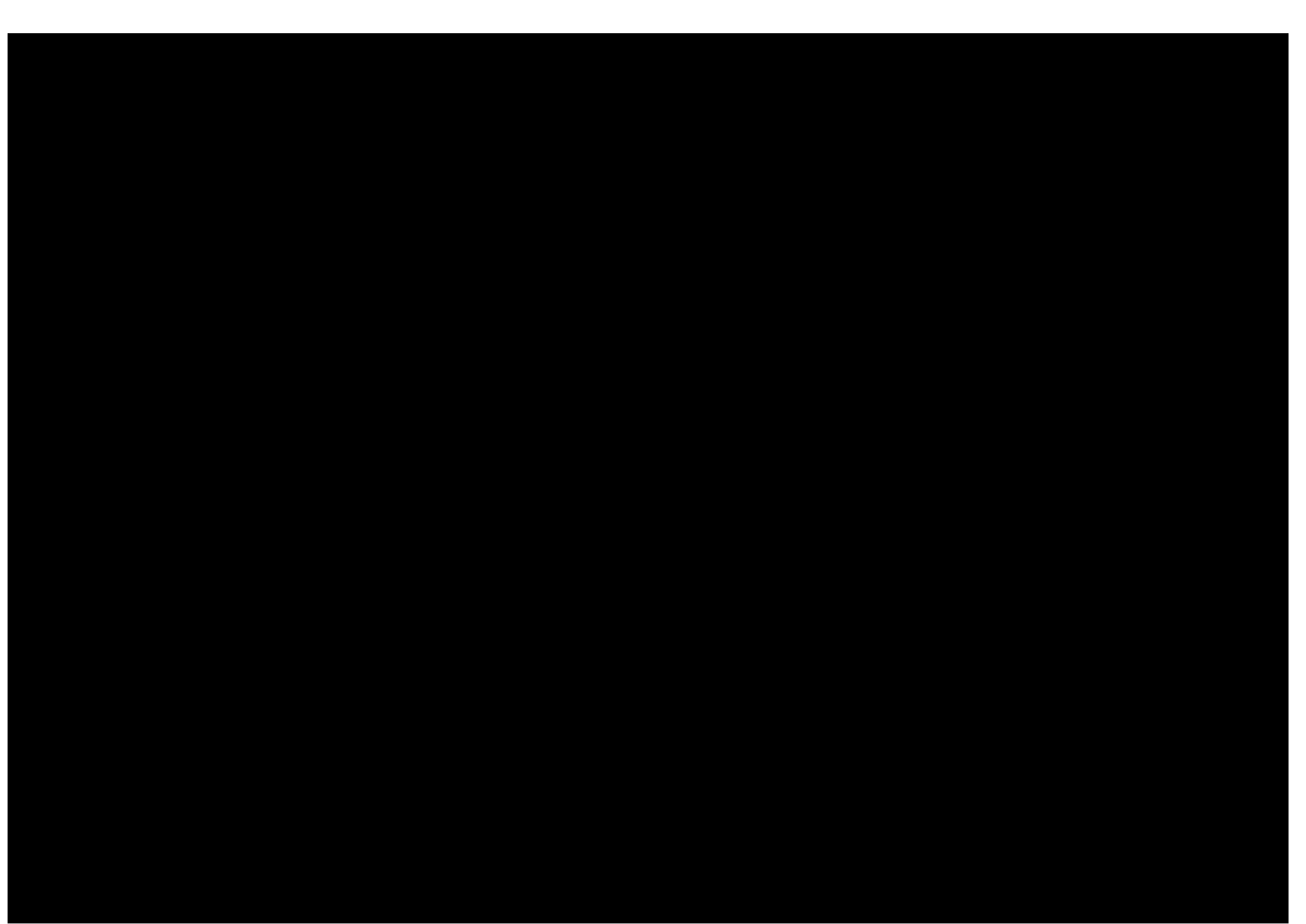

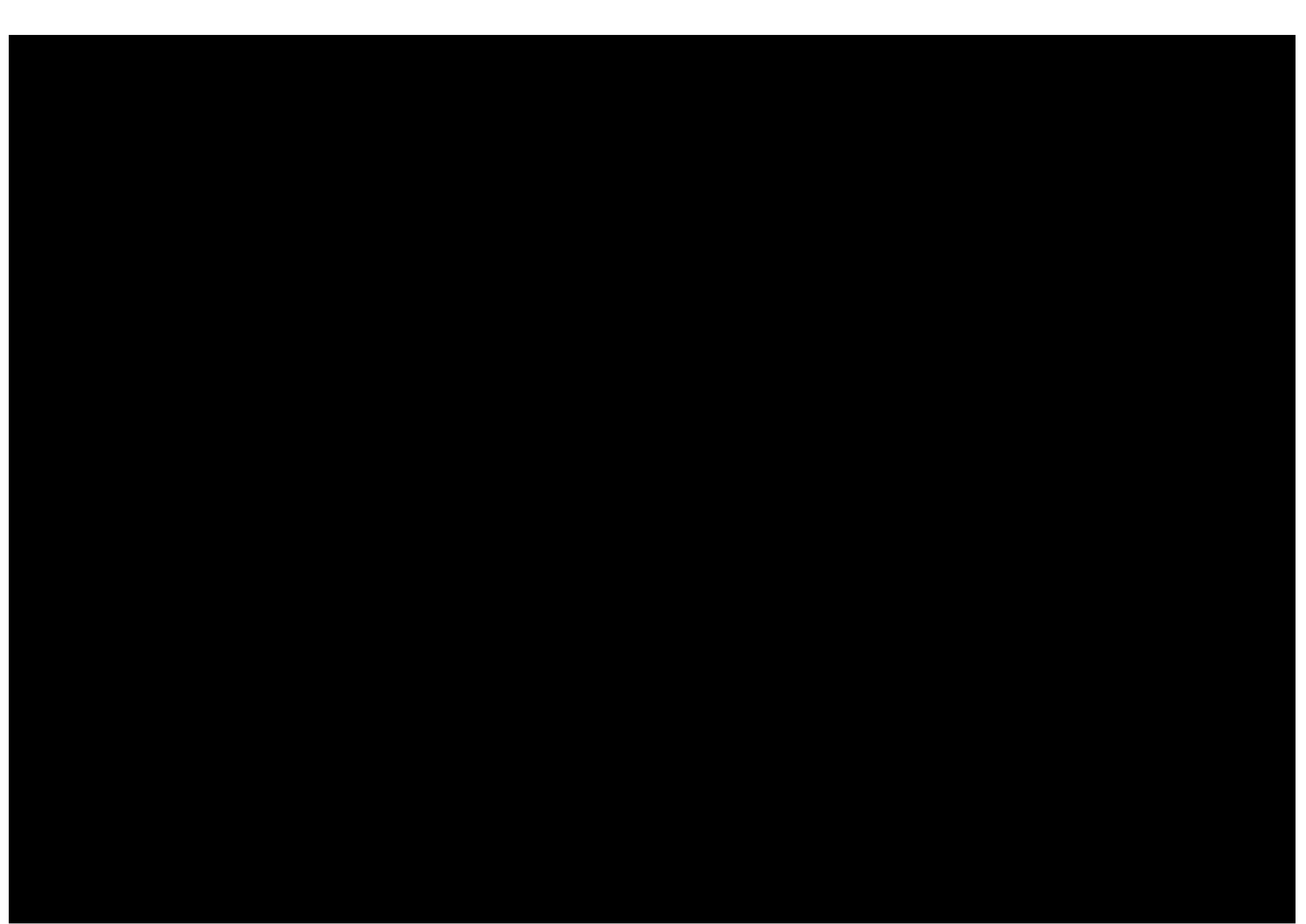

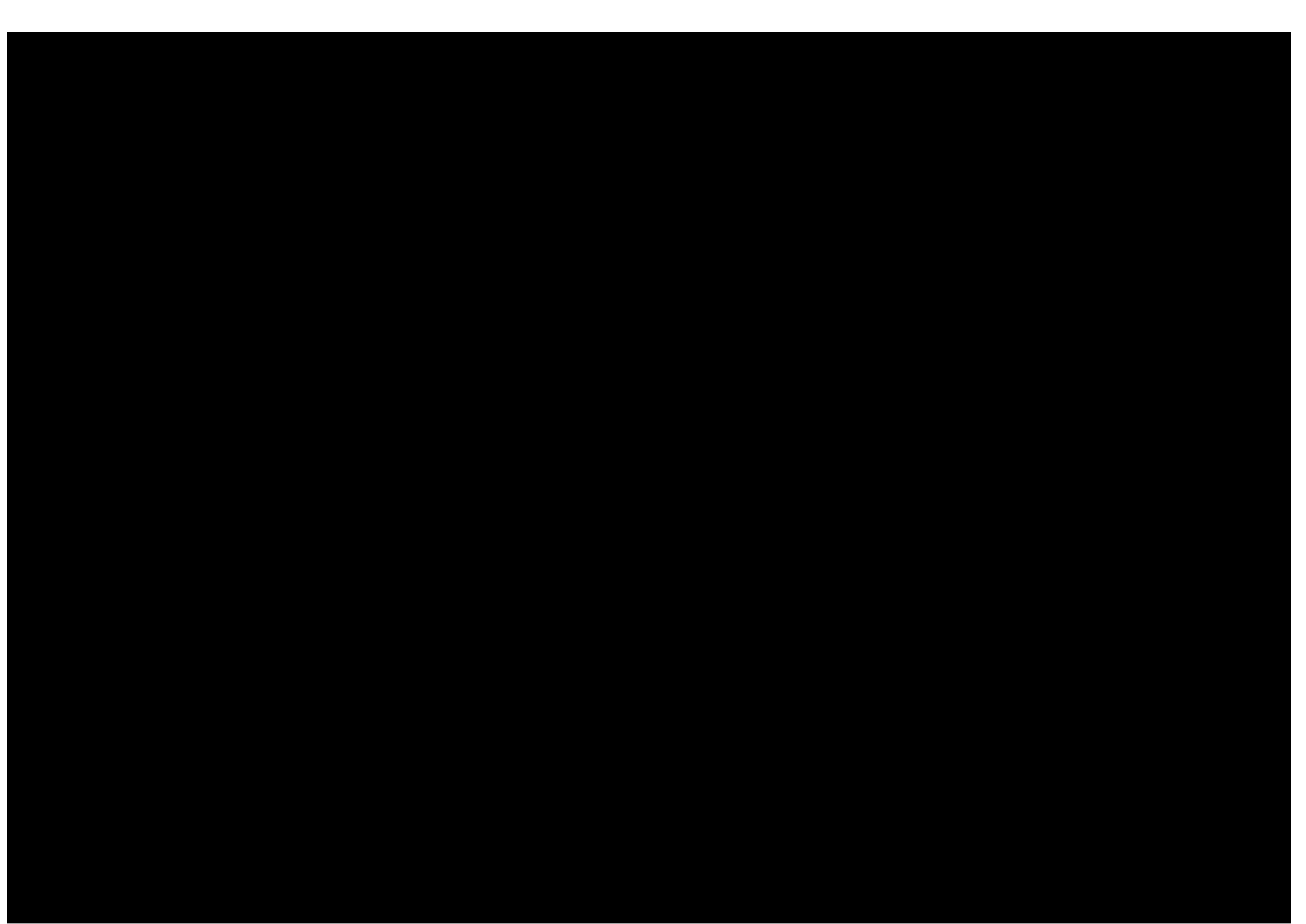

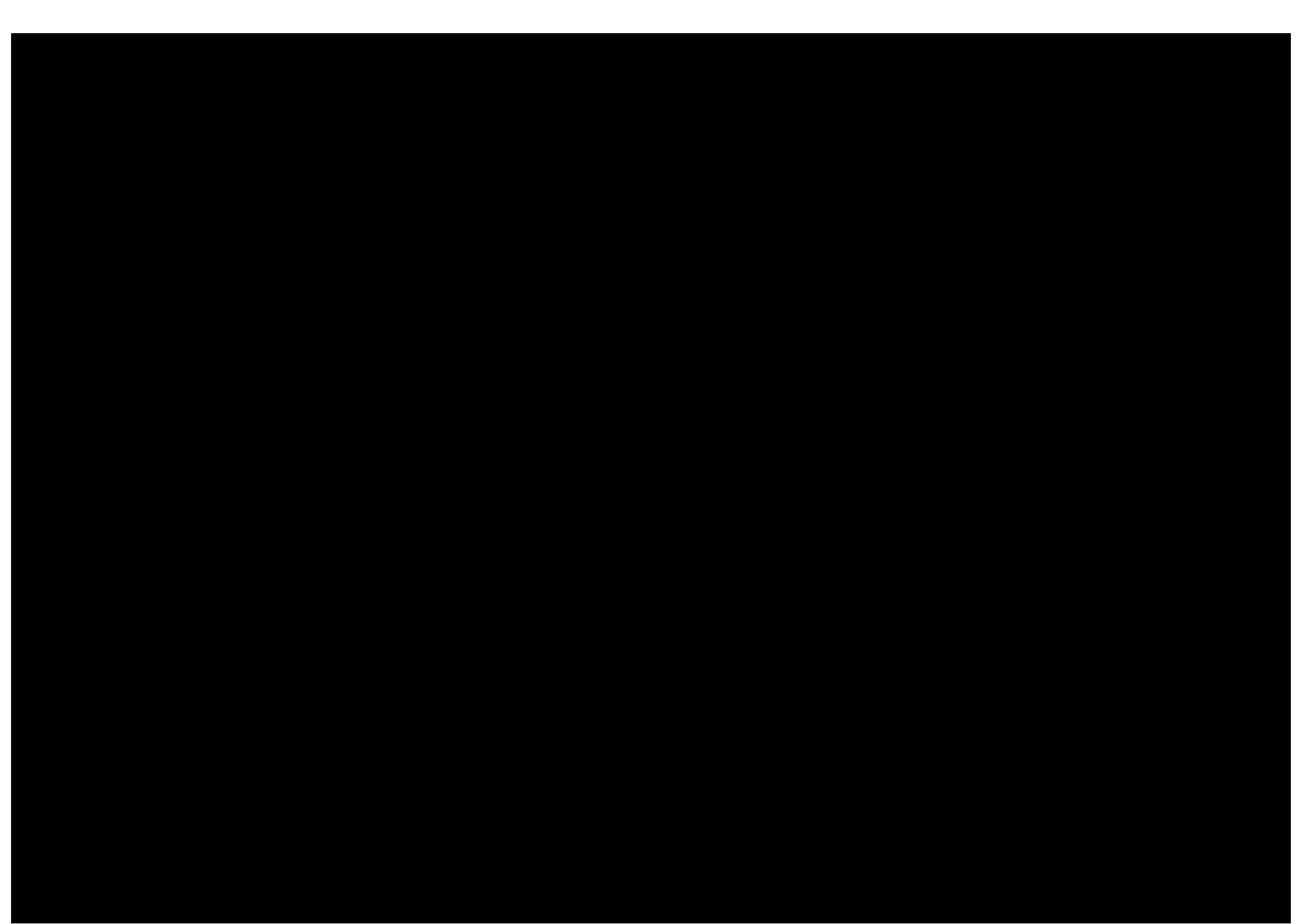

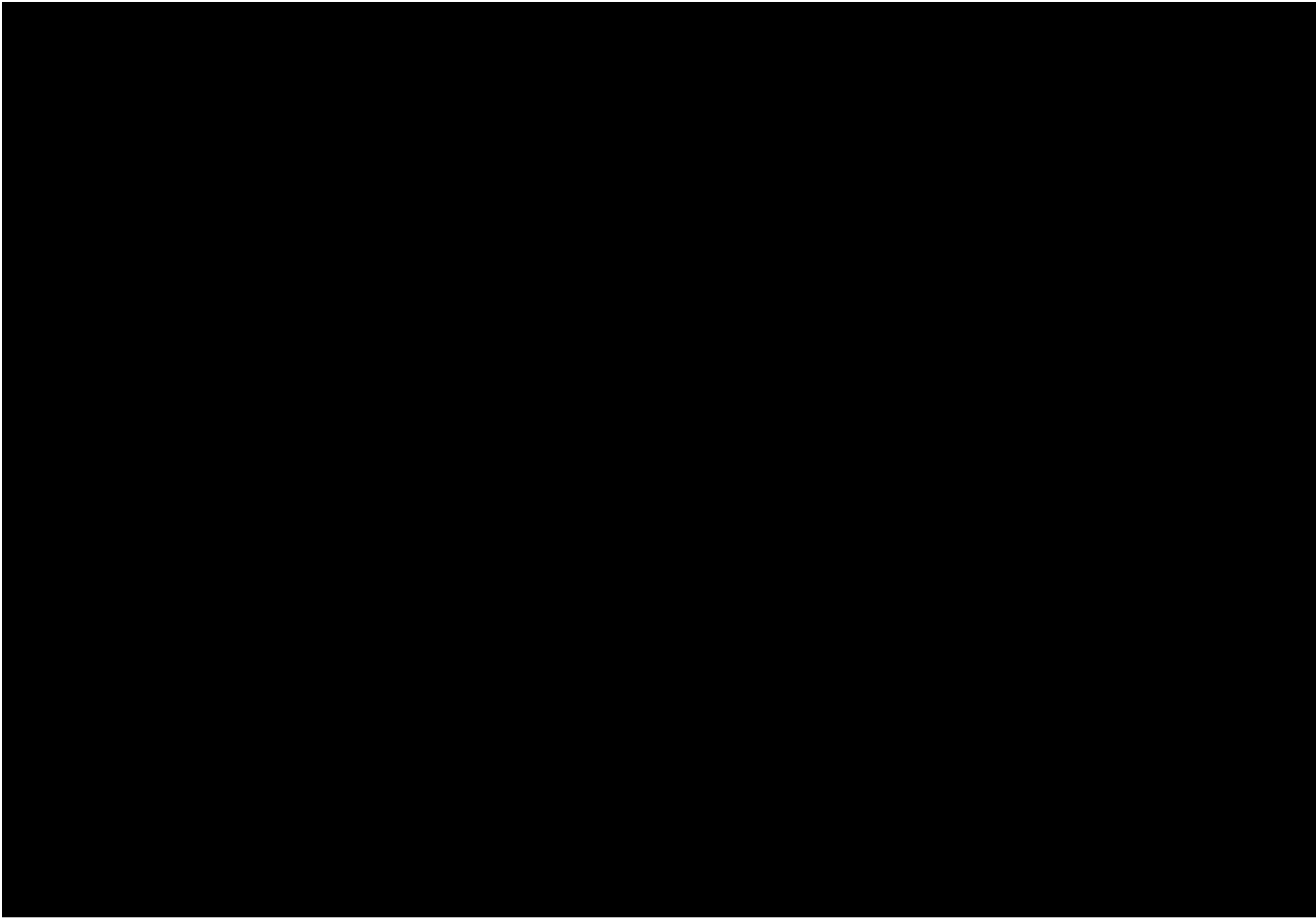

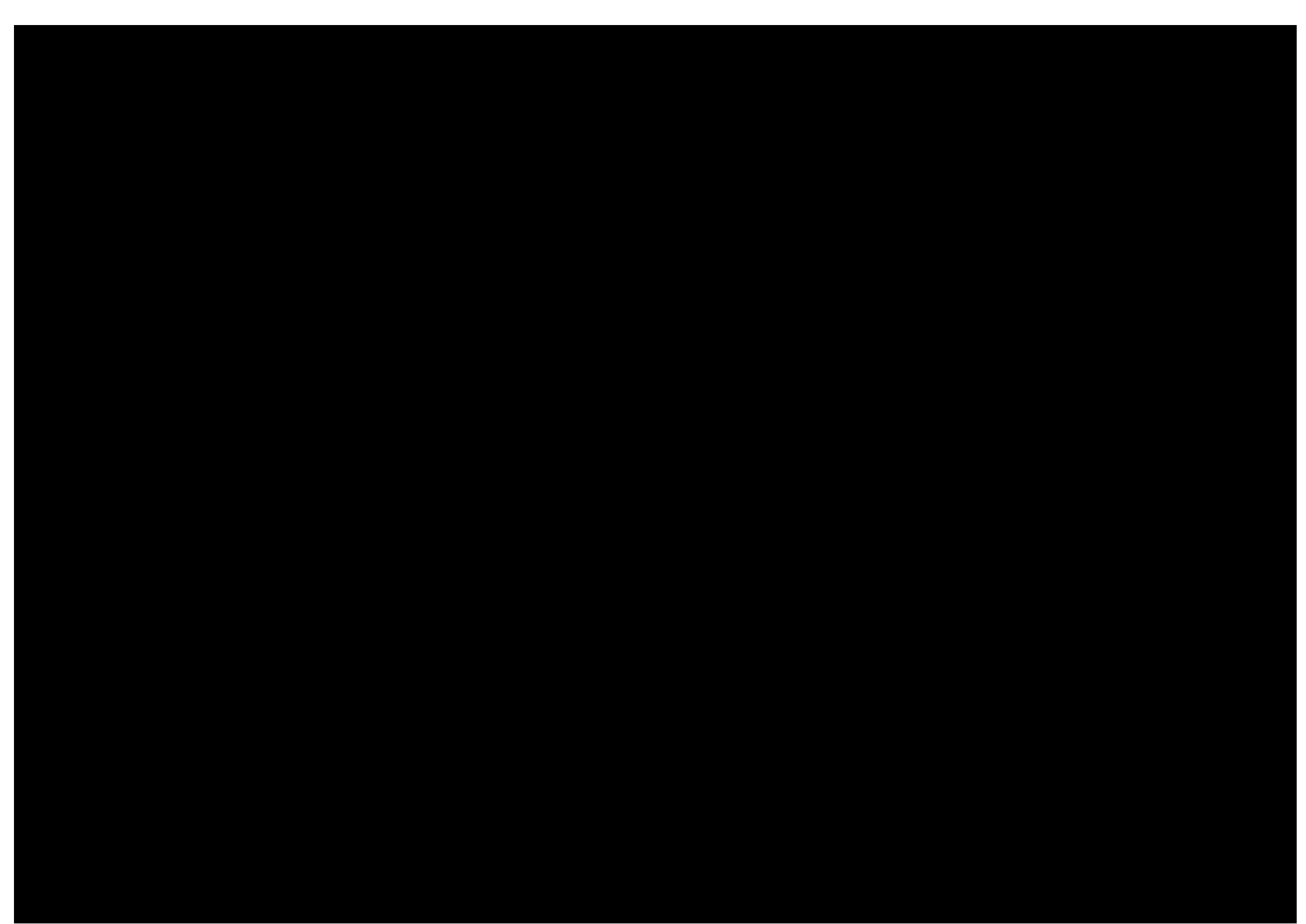

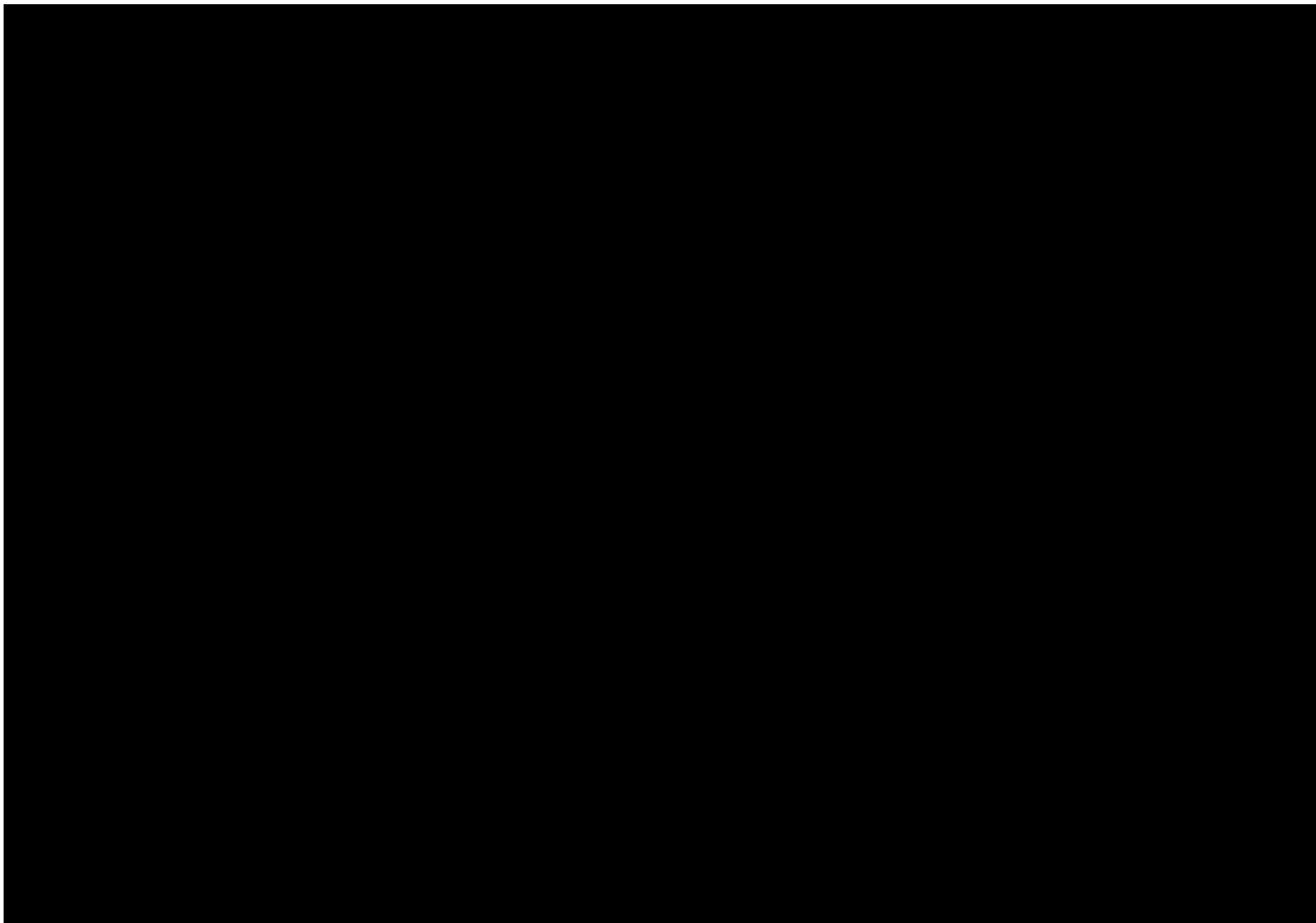



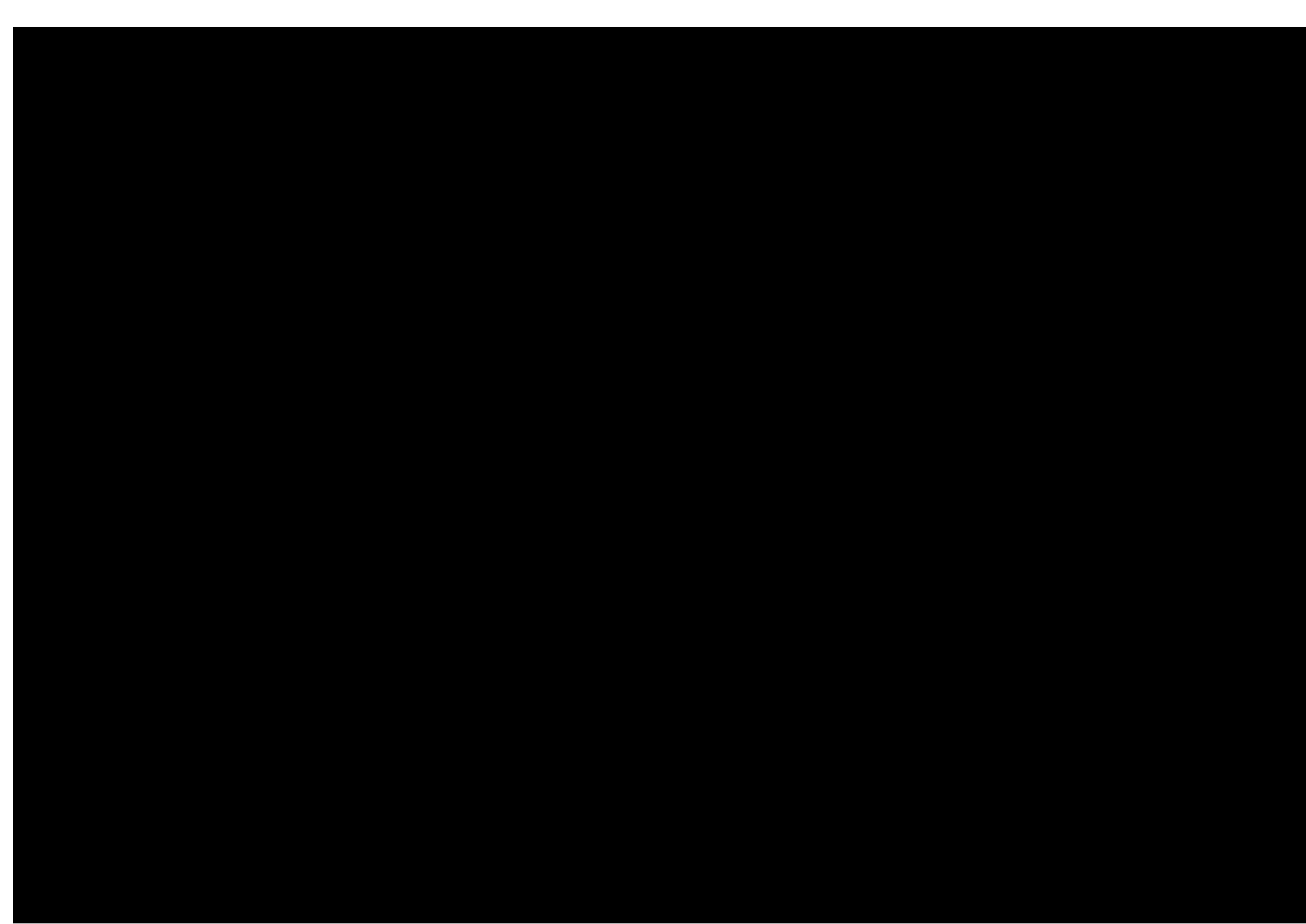

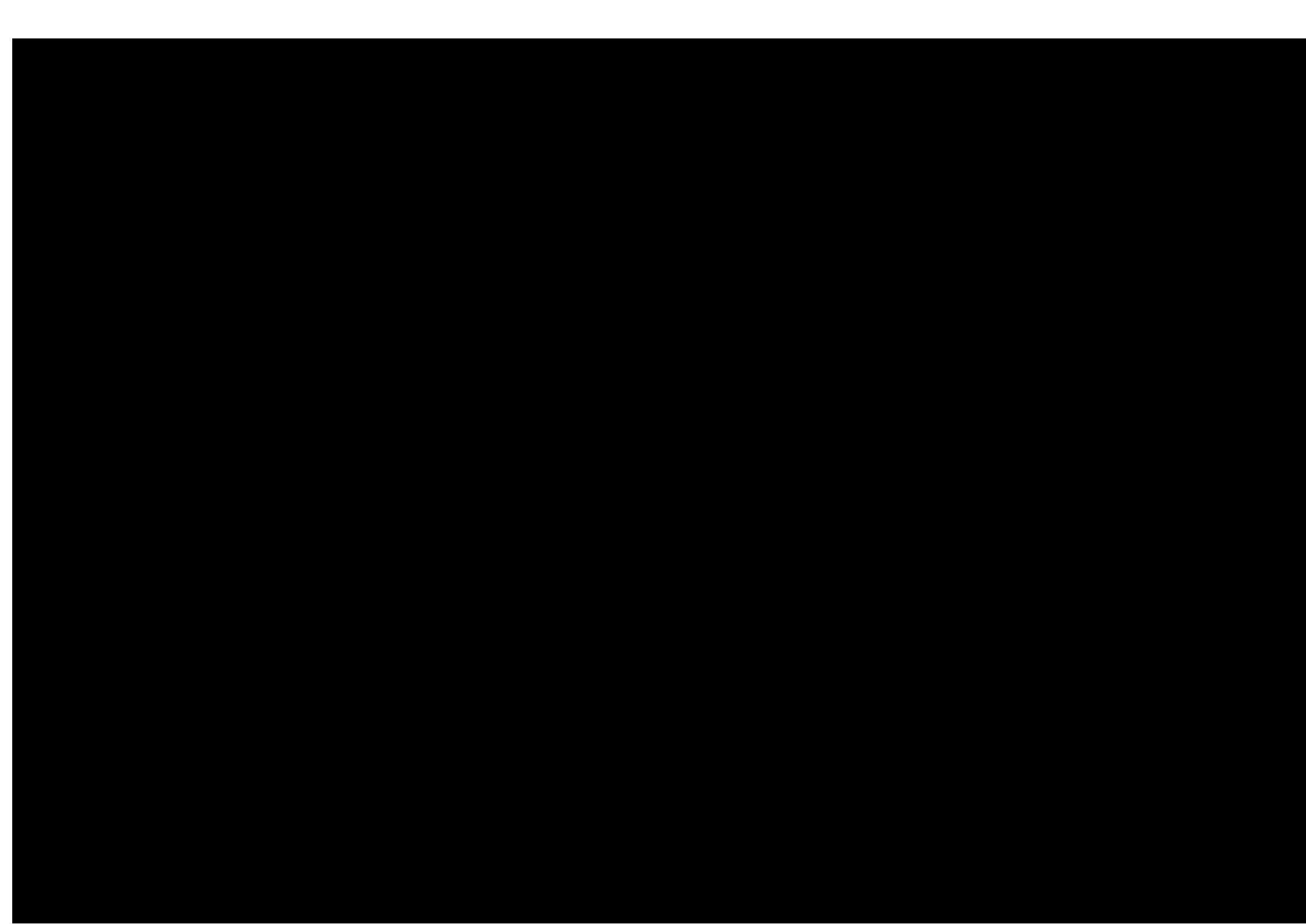

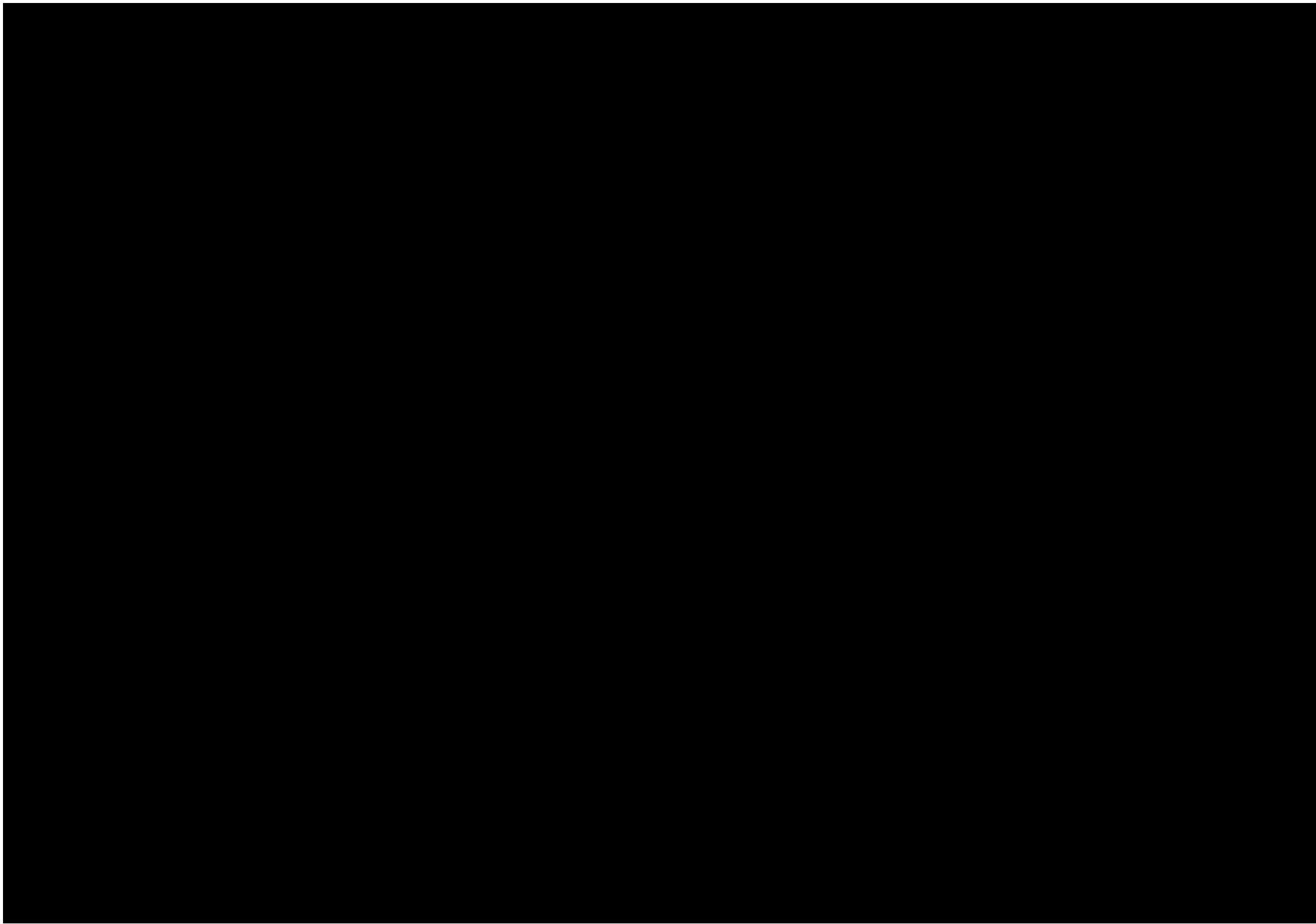

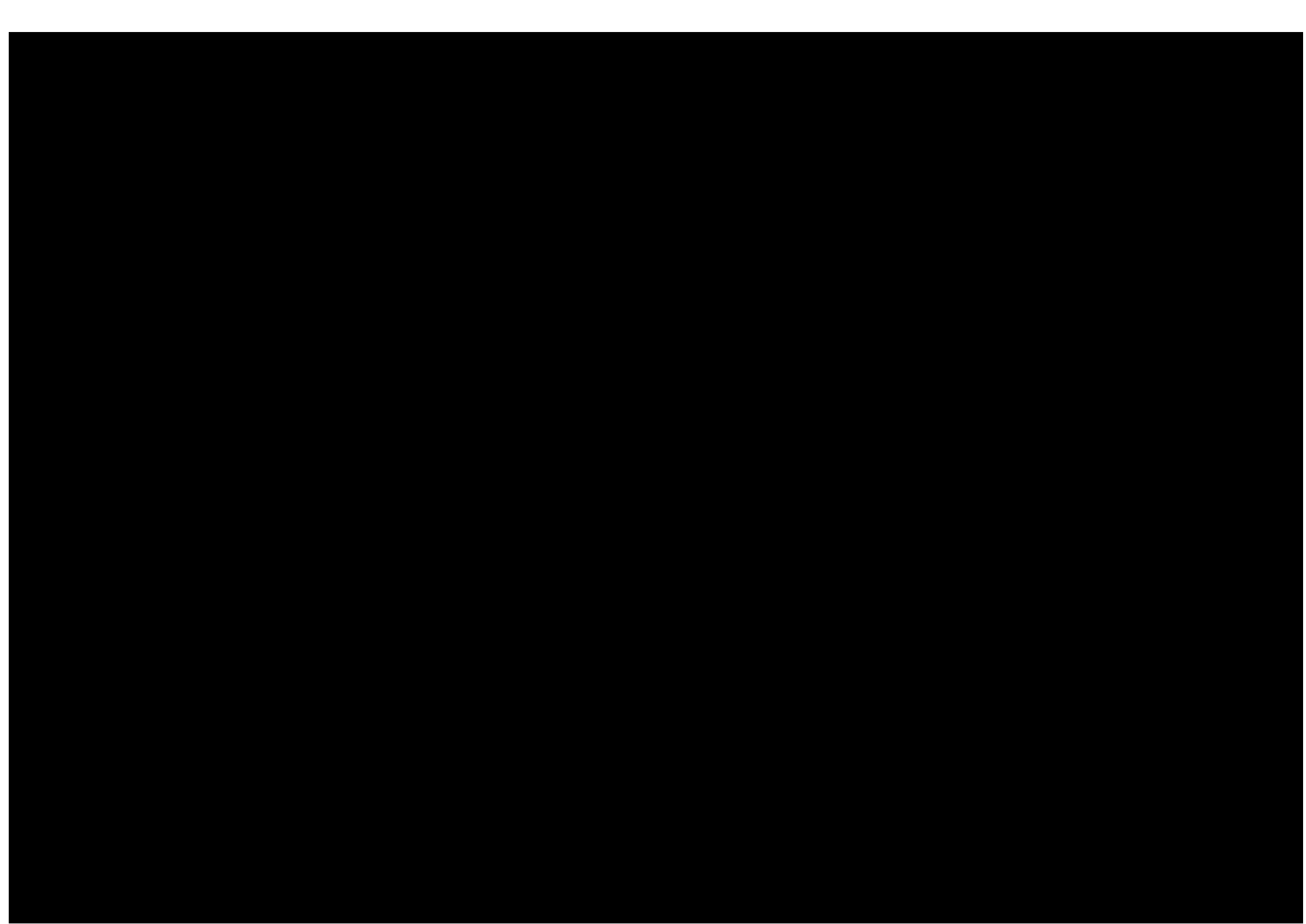

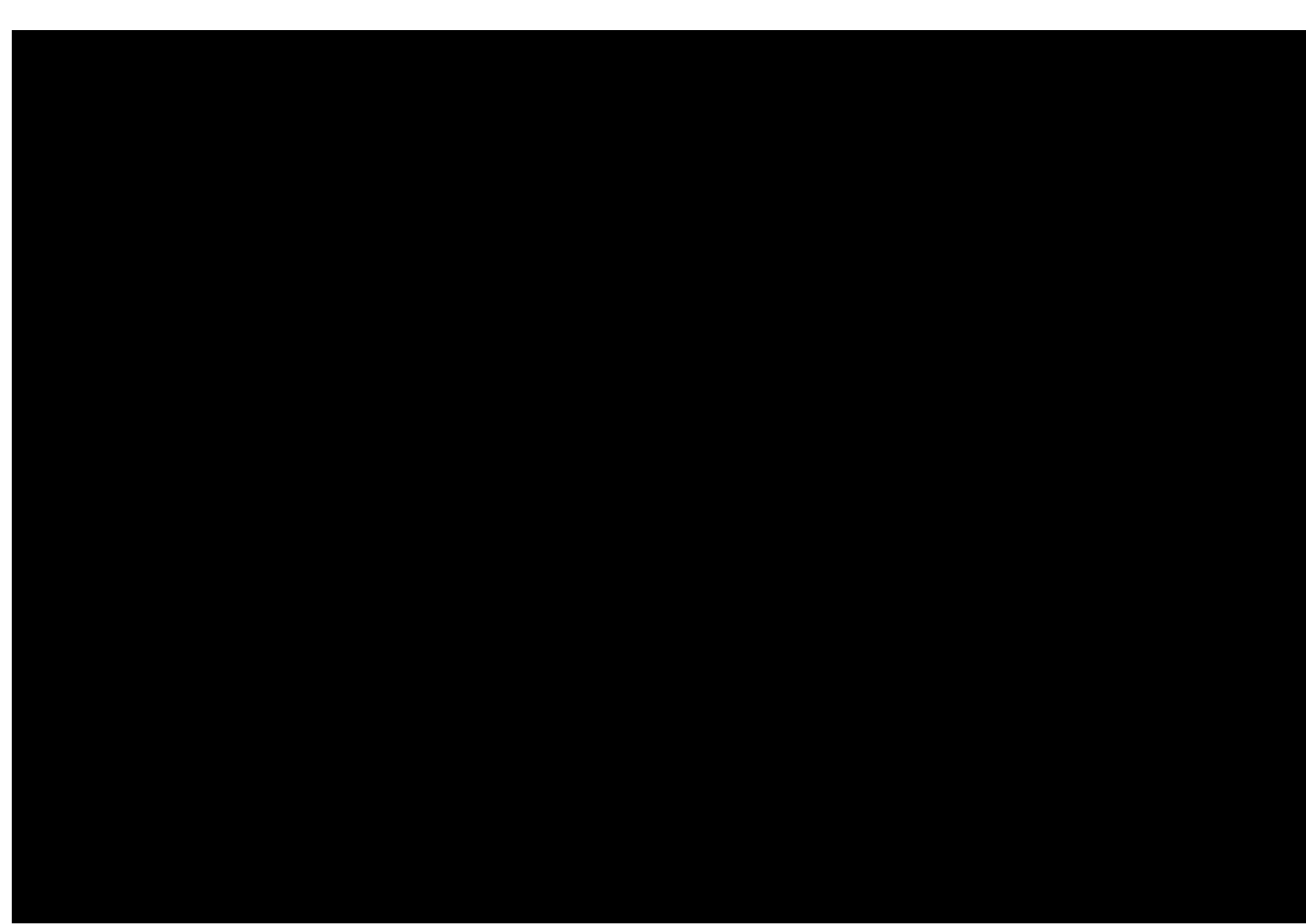

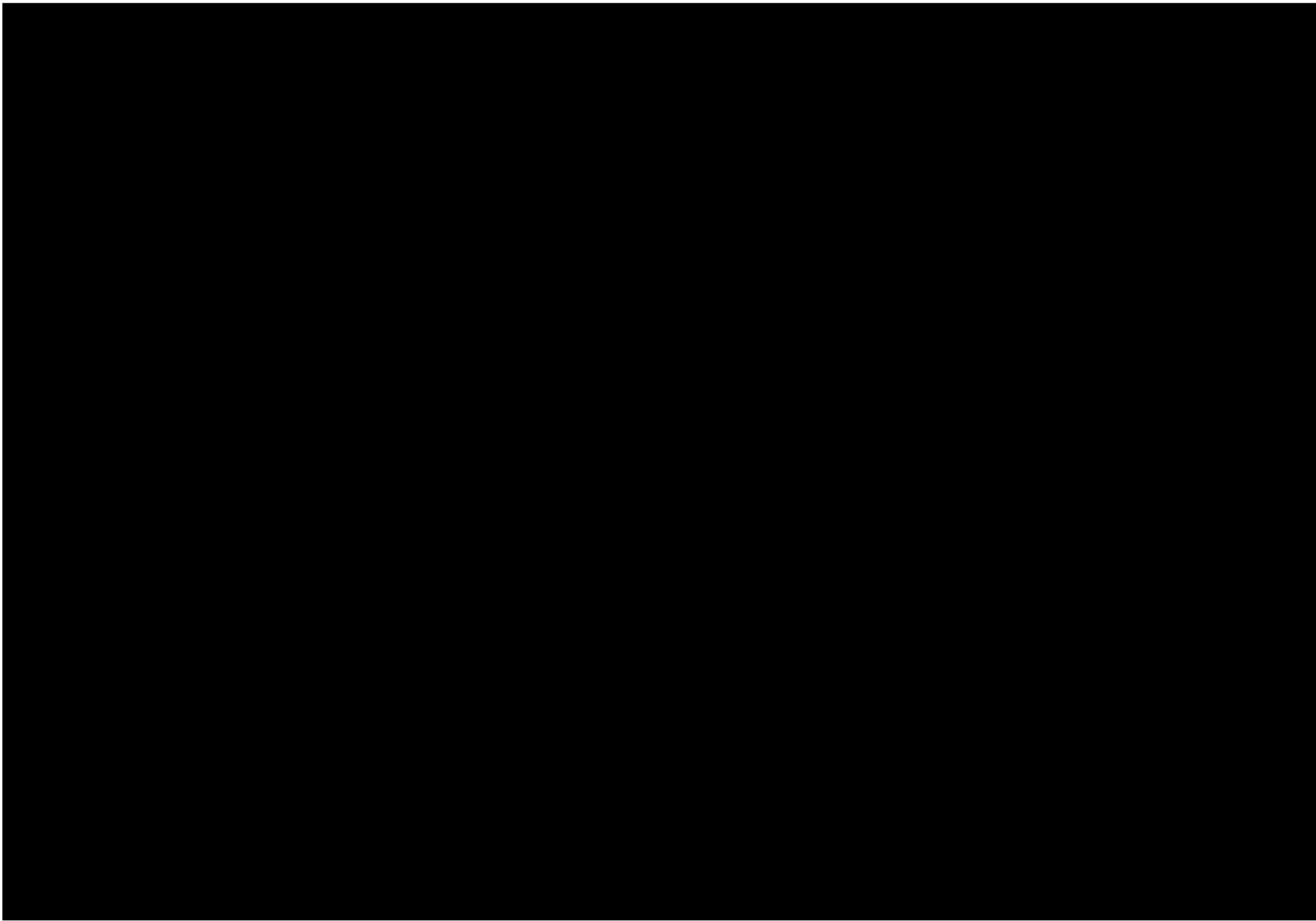

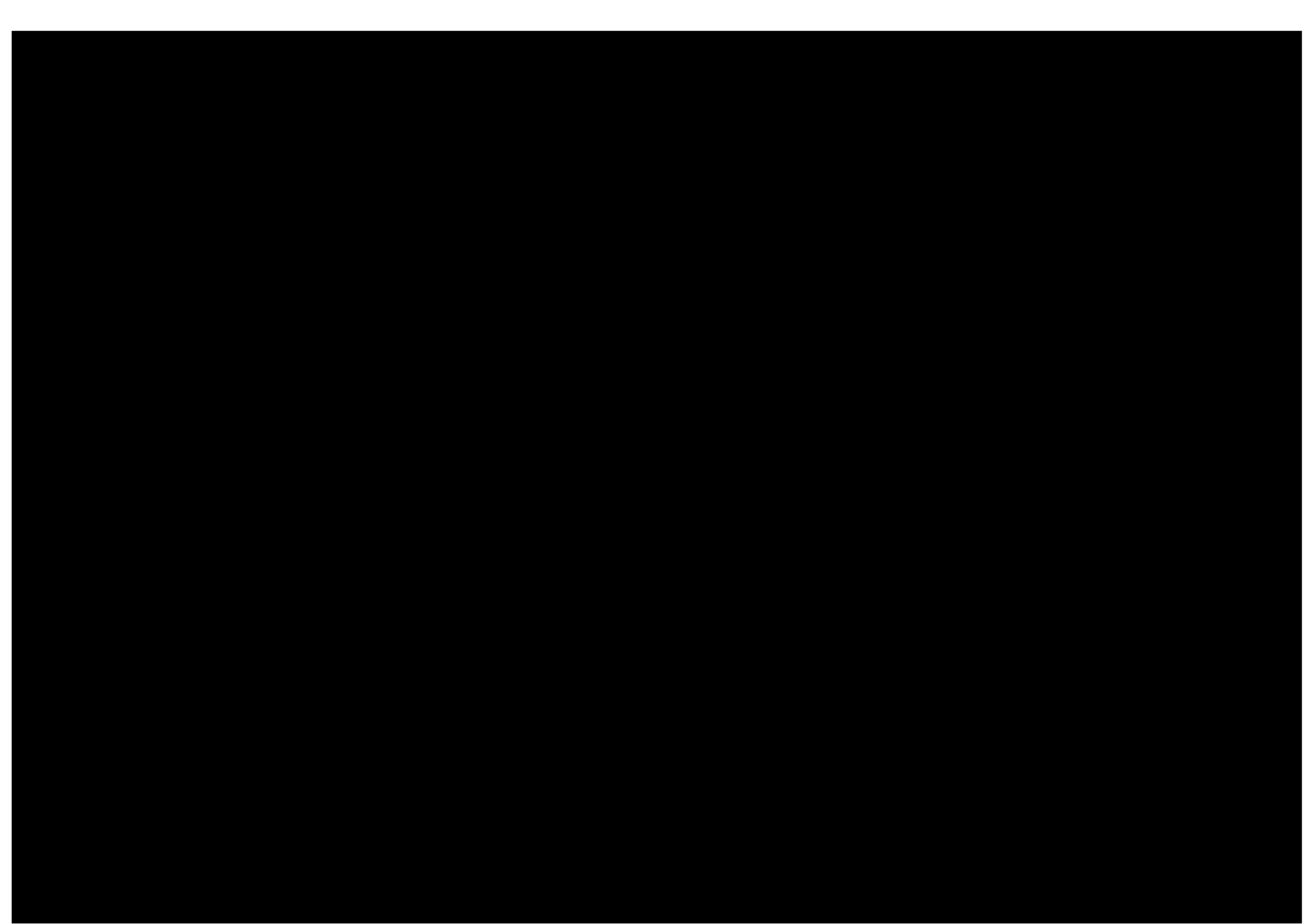



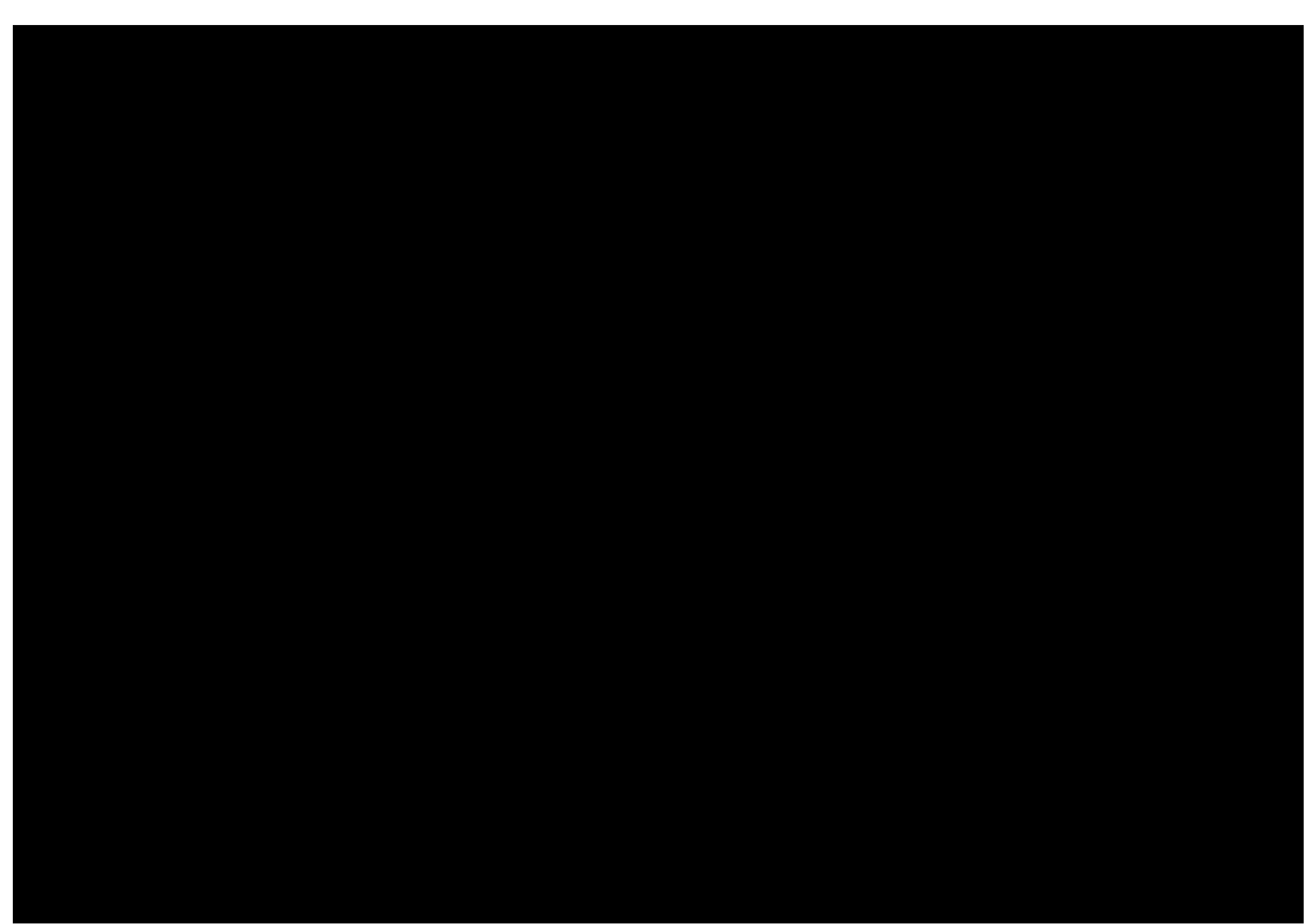

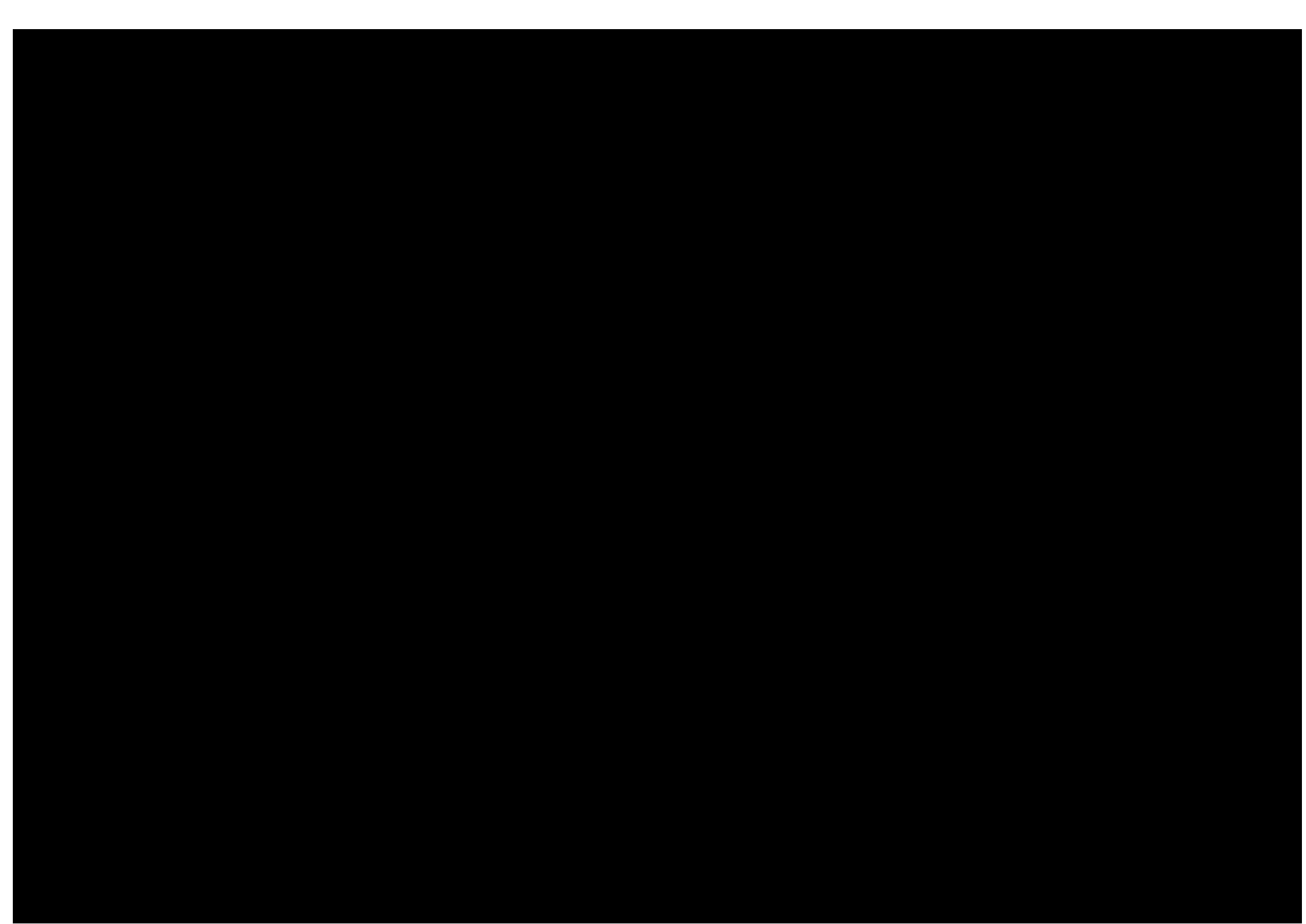



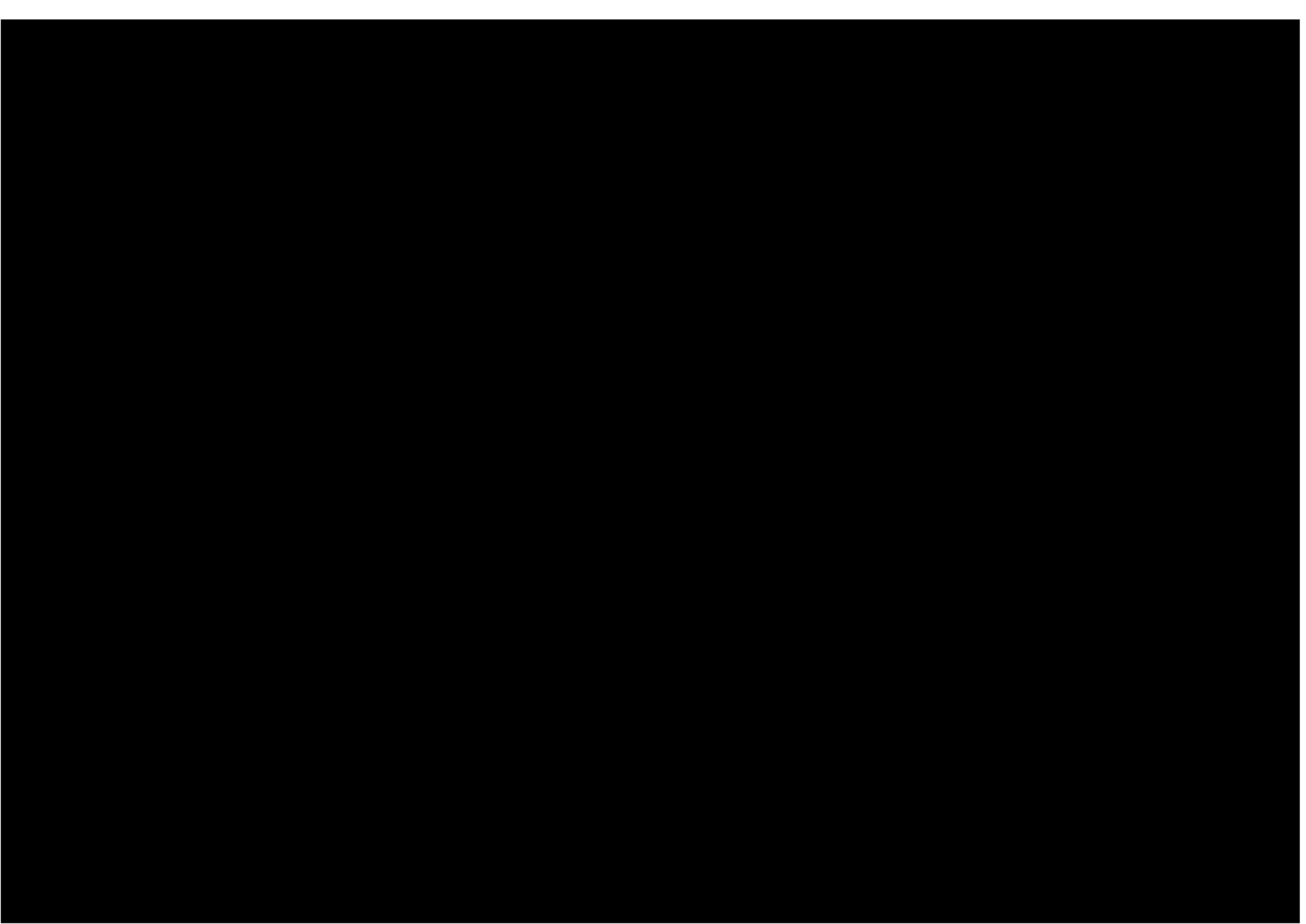

Accidents between dates 01/01/2016 and 31/08/2021 (68) months
 Selection: Notes:
 Selected using Manual Selection

Thursday 24/03/2016 Time 1750 Slight at B4030 APPROX 300M NW OF J/W B430 MIDDLETON STONEY
 E: 453192 N: 223667 Junction Detail: 0 Control
 Raining without high winds Road surface Wet/Damp Daylight
 Vehicle Reference 1 Car Moving from SE to N Going ahead other
 Casualty Reference 1 Age 28 Female Driver/rider Severity Slight Injured by vehicle 1
 Vehicle Reference 2 Car Moving from N to SE Going ahead other

Wednesday 06/04/2016 Time 1641 Slight at B4030 J/W PORT WAY LOWER HEYFORD
 E: 449989 N: 224437 Junction Detail: 3 Control 4
 Fine without high winds Road surface Dry Daylight
 Vehicle Reference 1 Car Moving from S to N Stopping
 Casualty Reference: 1 Age: 21 Female Driver/rider Severity: Slight Injured by vehicle: 1
 Casualty Reference: 3 Age: 18 Male Passenger Severity: Slight Injured by vehicle: 1
 Vehicle Reference 2 Car Moving from E to W Going ahead other
 Casualty Reference: 2 Age: 44 Female Driver/rider Severity: Slight Injured by vehicle: 2

Wednesday 27/04/2016 Time 1645 Slight at CAMP ROAD APPROX 175M W OF RBT J/W DACEY DRIVE UPPER HEYFORD
 E: 450757 N: 225856 Junction Detail: 0 Control
 Fine without high winds Road surface Dry Daylight
 Vehicle Reference 1 Car Moving from W to E Going ahead other
 Casualty Reference: 1 Age: 34 Female Driver/rider Severity: Slight Injured by vehicle: 1

Accidents between dates 01/01/2016 and 31/08/2021 (68) months

Selection: Notes:

Selected using Manual Selection

Wednesday 22/06/2016 Time 1238 Slight at B4030 AT EXIT FROM EXIT FROM LAYBY OPPOSITE CAULCOTT VILLAGE TURN (SOUTH ST) LOWE
 E: 450842 N: 224378 Junction Detail: 3 Control 4
 Fine without high winds Road surface Dry Daylight
 Vehicle Reference 1 Car Moving from N to S Starting
 Vehicle Reference 2 Car Moving from W to E Going ahead other
 Casualty Reference 1 Age 53 Female Driver/rider Severity Slight Injured by vehicle 2

Wednesday 30/11/2016 Time 1935 Slight at CAMP ROAD AT BEND APPROX 230M SE OF J/W ROAD TO ARDLEY MIDDLETON STONEY
 E: 452261 N: 225473 Junction Detail: 0 Control
 Fine without high winds Road surface Frost/Ice Darkness: no street lighting
 Vehicle Reference 1 Car Moving from N to S Going ahead right bend
 Casualty Reference: 1 Age: 20 Female Passenger Severity: Slight Injured by vehicle: 1

Monday 06/02/2017 Time 1715 Slight at B430 80M N OF J/W HEYFORD ROAD ARDLEY
 E: 453800 N: 225650 Junction Detail: 0 Control
 Raining without high winds Road surface Wet/Damp Darkness no street lighting
 Vehicle Reference 1 Car Moving from S to N Overtaking moving vehicle O/S
 Casualty Reference: 1 Age: 54 Male Driver/rider Severity: Slight Injured by vehicle: 1
 Vehicle Reference 2 Car Moving from S to N Going ahead other

Accidents between dates 01/01/2016 and 31/08/2021 (68) months

Selection: Notes:

Selected using Manual Selection

Sunday	16/04/2017	Time	2007	Serious	at	B4030 AT BEND APPROX 75M E OF ACCESS TO LIME HOLLOW	UPPER HEYFORD
E: 451807	N: 224591	Junction Detail:	0	Control			
Fine without high winds		Road surface	Dry			Daylight	
Vehicle Reference 1	Car					Moving from SE to S	Going ahead left bend
Casualty Reference	1	Age	34	Male		Driver/rider	Severity Serious Injured by vehicle 1
Friday	29/09/2017	Time	0545	Slight	at	B4030 AT BEND BY ACCESS OT PARK FARM	MIDDLETON STONEY
E: 452025	N: 224361	Junction Detail:	0	Control			
Other		Road surface	Wet/Damp			Darkness: no street lighting	
Vehicle Reference 1	Car					Moving from N to E	Going ahead left bend
Casualty Reference:	1	Age:	17	Female		Driver/rider	Severity: Slight Injured by vehicle: 1
Tuesday	20/02/2018	Time	0843	Fatal	at	PORTWAY APPROX 400M S OF J/W B4030	LOWER HEYFORD
E: 449941	N: 224041	Junction Detail:	0	Control			
Fine without high winds		Road surface	Wet/Damp			Daylight	
Vehicle Reference 1	Car					Moving from S to N	Going ahead other
Casualty Reference:	1	Age:	37	Female		Driver/rider	Severity: Fatal Injured by vehicle: 1
Vehicle Reference 2	Car					Moving from N to S	Going ahead other
Casualty Reference:	2	Age:	45	Female		Driver/rider	Severity: Slight Injured by vehicle: 2
Casualty Reference:	3	Age:	6	Female		Passenger	Severity: Slight Injured by vehicle: 2

Accidents between dates 01/01/2016 and 31/08/2021 (68) months

Selection: Notes:

Selected using Manual Selection

Thursday 24/05/2018 Time 1209 Slight at CAMP RD APPROX 650M N OF J/W B4030 UPPER HEYFORD
 E: 452340 N: 225049 Junction Detail: 0 Control
 Fine without high winds Road surface Wet/Damp Daylight
 Vehicle Reference 1 Car Moving from S to N Going ahead left bend
 Casualty Reference 1 Age 37 Male Driver/rider Severity Slight Injured by vehicle 1

Thursday 13/12/2018 Time 0802 Serious at B4030 AT BEND 750M E OF J/W SOUTH STREET CAULCOT LOWER HEYFORD
 E: 451537 N: 224461 Junction Detail: 0 Control
 Fine without high winds Road surface Frost/Ice Daylight
 Vehicle Reference 1 Motor Cycle over 50 cc and up to 125cc Moving from W to NE Going ahead left bend
 Casualty Reference: 1 Age: 25 Male Driver/rider Severity: Serious Injured by vehicle: 1

Monday 25/02/2019 Time 1715 Slight at B4030 J/W CAMP ROAD MIDDLETON STONEY
 E: 452495 N: 224437 Junction Detail: 3 Control 4
 Fine without high winds Road surface Dry Daylight
 Vehicle Reference 1 Car Moving from N to S Waiting to turn left
 Casualty Reference: 1 Age: 26 Male Driver/rider Severity: Slight Injured by vehicle: 1
 Vehicle Reference 2 Car Moving from N to S Going ahead but held up

Accidents between dates 01/01/2016 and 31/08/2021 (68) months

Selection: Notes:

Selected using Manual Selection

Friday 19/07/2019 Time 1715 Slight at B4030 STATION RD APPROX 320M E OF J/W THE LANE LOWER HEYFORD
E: 448950 N: 224644 Junction Detail: 0 Control
Raining without high winds Road surface Wet/Damp Daylight
Vehicle Reference 1 Car Moving from E to W Going ahead other
Casualty Reference 1 Age 20 Male Pedestrian Severity Slight Injured by vehicle 1

Tuesday 23/07/2019 Time 1728 Slight at B4030 J/W CAMP ROAD MIDDLETON STONEY
E: 452494 N: 224435 Junction Detail: 3 Control 4
Fine without high winds Road surface Dry Daylight
Vehicle Reference 1 Car Moving from N to S Going ahead other
Vehicle Reference 2 Car Moving from N to S Waiting to turn left
Casualty Reference: 1 Age: 31 Female Driver/rider Severity: Slight Injured by vehicle: 2

Tuesday 06/08/2019 Time 1609 Serious at B430 J/W HEYFORD ROAD ARDLEY
E: 453780 N: 225569 Junction Detail: 3 Control 4
Fine without high winds Road surface Dry Daylight
Vehicle Reference 1 Goods 7.5 tonnes mgw and over Moving from W to S Turning right
Vehicle Reference 2 Motor Cycle over 50 cc and up to 125cc Moving from S to N Overtaking moving vehicle O/S
Casualty Reference: 1 Age: 36 Male Driver/rider Severity: Serious Injured by vehicle: 2
Vehicle Reference 3 Goods 7.5 tonnes mgw and over Moving from S to W Turning left

Accidents between dates 01/01/2016 and 31/08/2021 (68) months
 Selection: Notes:
 Selected using Manual Selection

Wednesday 08/01/2020 Time 0743 Serious at CAMP ROADBY J/W IZZARD ROAD UPPER HEYFORD
 E: 450656 N: 225871 Junction Detail: 3 Control 4
 Fine without high winds Road surface Wet/Damp Daylight
 Vehicle Reference 1 Car Moving from W to E Going ahead other
 Casualty Reference 1 Age 11 Female Pedestrian Severity Serious Injured by vehicle 1

Thursday 27/08/2020 Time 2029 Serious at CAMP ROAD APPROX 200M W OF J/W WELLINGTON ROAD UPPER HEYFORD
 E: 451298 N: 225788 Junction Detail: 0 Control
 Fine without high winds Road surface Wet/Damp Daylight
 Vehicle Reference 1 Car Moving from E to W Going ahead other
 Casualty Reference: 1 Age: 22 Male Driver/rider Severity: Serious Injured by vehicle: 1

Sunday 22/11/2020 Time 1133 Slight at B4030 MIDDLETON STONEY J/W CAMP ROAD MIDDLETON STONEY
 E: 452497 N: 224424 Junction Detail: 3 Control 4
 Fine without high winds Road surface Dry Daylight
 Vehicle Reference 1 Car Moving from N to SE Turning left
 Vehicle Reference 2 Pedal Cycle Moving from W to SE Going ahead right bend
 Casualty Reference: 1 Age: 32 Male Driver/rider Severity: Slight Injured by vehicle: 2

Accidents between dates 01/01/2016 and 31/08/2021 (68) months

Selection: Notes:

Selected using Manual Selection

Friday 11/12/2020 Time 1240 Serious at CAMP ROAD AT TRAFFIC CALMING NARROWING 20M W OF KIRTLINGTON ROAD UPPER HEYFORD
 E: 450207 N: 225925 Junction Detail: 0 Control
 Fine without high winds Road surface Wet/Damp Daylight
 Vehicle Reference 1 Car Moving from W to E Going ahead other
 Vehicle Reference 2 Pedal Cycle Moving from E to W Going ahead other
 Casualty Reference 1 Age 39 Male Driver/rider Severity Serious Injured by vehicle 2

Thursday 27/05/2021 Time 1549 Slight at CAMP ROAD J/W HEYFORD FREE SCHOOL ENTRANCE UPPER HEYFORD
 E: 451538 N: 225760 Junction Detail: 3 Control 4
 Fine without high winds Road surface Dry Daylight
 Vehicle Reference 1 Car Moving from W to E Going ahead other
 Casualty Reference: 1 Age: 11 Male Pedestrian Severity: Slight Injured by vehicle: 1

T19562
Heyford Park



Appendix C

Junction Impact Assessment

T19562**Upper Heyford - Junction Impact Assessment****Junction 1 - A43/M40 J10 Southbound off slip**

Approach	2031 Ref. Case		2031 With Dev Difference			
	AM	PM	AM		PM	
			Flow	% Impact	Flow	% Impact
A43 (N)	1952	1639	-1	-0.05%	7	0.43%
A43 (S)	1529	2243	11	0.71%	4	0.18%
slip	1072	985	1	0.09%	2	0.20%
TOTAL	4553	4867	11	0.24%	13	0.27%

Junction 2 - A43/M40 J10 (Services and on slip)

Approach	2031 Ref. Case		2031 With Dev Difference			
	AM	PM	AM		PM	
			Flow	% Impact	Flow	% Impact
A43 (N)	2750	2133	2	0.07%	7	0.33%
Services	613	629	0	0.00%	0	0.00%
A43 (W)	1729	2438	12	0.69%	4	0.16%
TOTAL	5092	5200	14	0.27%	11	0.21%

Junction 3 - A43/M40 J10 (slips)/B430

Approach	2031 Ref. Case		2031 With Dev Difference			
	AM	PM	AM		PM	
			Flow	% Impact	Flow	% Impact
A43 (E)	1409	1309	0	0.00%	1	0.08%
slips	509	2094	1	0.20%	4	0.19%
B430	616	675	13	2.07%	-1	-0.15%
TOTAL	2534	4078	14	0.55%	4	0.10%

Junction 4 - A43/B4100

Approach	2031 Ref. Case		2031 With Dev Difference			
	AM	PM	AM		PM	
			Flow	% Impact	Flow	% Impact
A43 (N)	2564	1835	-1	-0.04%	6	0.33%
B4100 (E)	681	978	5	0.73%	0	0.00%
A43 (S)	1977	2735	10	0.50%	4	0.15%
A4100 (W)	242	190	4	1.63%	0	0.00%
TOTAL	5464	5738	18	0.33%	10	0.17%

Junction 5 - A34/B430 Northbound slips

Approach	2031 Ref. Case		2031 With Dev Difference			
	AM	PM	AM		PM	
			Flow	% Impact	Flow	% Impact
A34 (SW)	4126	4371	2	0.05%	11	0.25%
B430	14	22	1	6.67%	-1	-4.76%
TOTAL	4140	4393	3	0.07%	10	0.23%

Junction 6 - A34/B430 Southbound slips

Approach	2031 Ref. Case		2031 With Dev Difference			
	AM	PM	AM		PM	
			Flow	% Impact	Flow	% Impact
A34 (NE)	3517	4176	8	0.23%	6	0.14%
B430	738	588	-5	-0.68%	-1	-0.17%
TOTAL	4255	4764	3	0.07%	5	0.10%

Junction 7 - B430/unnamed road

Approach	2031 Ref. Case		2031 With Dev Difference			
	AM	PM	AM		PM	
			Flow	% Impact	Flow	% Impact
B430 (N)	1149	798	0	0.00%	11	1.36%
B430 (S)	128	328	-4	-3.23%	-9	-2.82%
unnamed rd	890	731	54	5.72%	21	2.79%
TOTAL	2167	1857	50	2.26%	23	1.22%

Junction 8 - B430/B4030

Approach	2031 Ref. Case		2031 With Dev Difference			
	AM	PM	AM		PM	
			Flow	% Impact	Flow	% Impact
B430 (N)	1278	1005	18	1.39%	3	0.30%
B4030 (E)	606	602	-8	-1.34%	-15	-2.56%
B430 (S)	339	647	7	2.02%	17	2.56%
B4030 (W)	37	38	0	0.00%	0	0.00%
TOTAL	2260	2292	17	0.75%	5	0.22%

Junction 9 - A4095/B430

Approach	2031 Ref. Case		2031 With Dev Difference			
	AM	PM	AM		PM	
			Flow	% Impact	Flow	% Impact
B430 (N)	801	645	-7	-0.88%	-15	-2.38%
A4095 (E)	254	281	3	1.17%	18	6.02%
B430 (S)	115	461	3	2.54%	3	0.65%
A4095 (W)	460	496	4	0.86%	-1	-0.20%
TOTAL	1630	1883	3	0.18%	5	0.26%

Junction 10 - A4095/B430

Approach	2031 Ref. Case		2031 With Dev Difference			
	AM	PM	AM		PM	
			Flow	% Impact	Flow	% Impact
B430 (N)	1215	842	10	0.82%	3	0.36%
B430 (S)	317	580	2	0.63%	1	0.17%
A4095	487	685	5	1.02%	7	1.01%
TOTAL	2019	2107	17	0.83%	11	0.52%

Junction 11 - B4030/Unnamed rd

Approach	2031 Ref. Case		2031 With Dev Difference			
	AM	PM	AM		PM	
			Flow	% Impact	Flow	% Impact
Unnamed rd	32	57	20	38.46%	5	8.06%
B4030 (SE)	620	649	13	2.05%	30	4.42%
B4030 (W)	57	35	3	5.00%	7	16.67%
TOTAL	709	741	36	4.83%	42	5.36%

Junction 12 - Camp Rd/Kirklington Rd

Approach	2031 Ref. Case		2031 With Dev Difference			
	AM	PM	AM		PM	
			Flow	% Impact	Flow	% Impact
Camp Rd (E)	387	241	17	4.21%	7	1.78%
Kirklington Rd	58	103	0	0.00%	-1	-0.98%
Camp Rd (W)	211	212	4	1.86%	14	6.19%
TOTAL	656	556	21	3.10%	20	3.47%

Junction 13 - Camp Rd/Somerton Rd

Approach	2031 Ref. Case		2031 With Dev Difference			
	AM	PM	AM		PM	
			Flow	% Impact	Flow	% Impact
Somerton Rd (N)	252	201	6	2.33%	9	3.45%
Camp Rd	219	198	13	5.60%	8	3.88%
Somerton Rd (S)	114	166	0	0.00%	4	2.35%
TOTAL	585	565	19	3.15%	21	3.58%

Junction 14 - B4030/Port Way

Approach	2031 Ref. Case		2031 With Dev Difference			
	AM	PM	AM		PM	
			Flow	% Impact	Flow	% Impact
Port Way (N)	168	42	3	1.75%	0	0.00%
B4030 (E)	179	284	-4	-2.29%	-1	-0.35%
Port Way (S)	76	151	0	0.00%	-1	-0.67%
B4030 (W)	270	162	4	1.46%	0	0.00%
TOTAL	693	639	3	0.43%	-2	-0.31%

Junction 15 - B4030/Station Rd/Freehold St

Approach	2031 Ref. Case		2031 With Dev Difference			
	AM	PM	AM		PM	
			Flow	% Impact	Flow	% Impact
Station Rd	184	141	5	2.65%	4	2.76%
B4030 (E)	195	331	-4	-2.09%	0	0.00%
B4030 (S)	239	202	2	0.83%	5	2.42%
Freehold St	26	11	1	3.70%	0	0.00%
TOTAL	644	685	4	0.62%	9	1.30%

Junction 16 - A4260/Somerton Rd/N Aston Rd

Approach	2031 Ref. Case		2031 With Dev Difference			
	AM	PM	AM		PM	
			Flow	% Impact	Flow	% Impact
A4260 (N)	1419	630	-3	-0.21%	6	0.94%
Somerton Rd	121	114	7	5.47%	3	2.56%
A4260 (S)	530	1159	1	0.19%	2	0.17%
N Aston Rd	78	58	1	1.27%	2	3.33%
TOTAL	2148	1961	6	0.28%	13	0.66%

Junction 17 - A4260/B4030

Approach	2031 Ref. Case		2031 With Dev Difference			
	AM	PM	AM		PM	
			Flow	% Impact	Flow	% Impact
A4260 (N)	1367	529	0	0.00%	1	0.19%
B4030 (E)	166	221	1	0.60%	2	0.90%
A4260 (S)	482	1105	3	0.62%	1	0.09%
B4030 (W)	201	141	1	0.50%	2	1.40%
TOTAL	2216	1996	5	0.23%	6	0.30%

Junction 18 - A4260/Unnamed road

Approach	2031 Ref. Case		2031 With Dev Difference			
	AM	PM	AM		PM	
			Flow	% Impact	Flow	% Impact
A4260 (N)	1358	493	-1	-0.07%	0	0.00%
Unnamed rd	59	69	2	3.28%	2	2.82%
A4260 (S)	485	1119	4	0.82%	2	0.18%
TOTAL	1902	1681	5	0.26%	4	0.24%

Junction 19 - A4260/Banbury Rd

Approach	2031 Ref. Case		2031 With Dev Difference			
	AM	PM	AM		PM	
			Flow	% Impact	Flow	% Impact
A4260 (N)	1417	562	1	0.07%	3	0.21%
A4260 (S)	442	1063	2	0.45%	2	0.19%
Banbury Rd	154	55	1	0.65%	1	1.79%
TOTAL	2013	1680	4	0.20%	6	0.36%

Junction 20 - A4260/B4027

Approach	2031 Ref. Case		2031 With Dev Difference			
	AM	PM	AM		PM	
			Flow	% Impact	Flow	% Impact
A4260 (N)	1459	519	2	0.14%	0	0.00%
B4027 (E)	138	589	2	1.43%	1	0.17%
A4260 (S)	430	693	2	0.46%	0	0.00%
B4027 (W)	203	238	-1	-0.50%	0	0.00%
TOTAL	2230	2039	5	0.22%	1	0.05%

Junction 21 - A4095/Port Way

Approach	2031 Ref. Case		2031 With Dev Difference			
	AM	PM	AM		PM	
			Flow	% Impact	Flow	% Impact
Port Way	435	275	23	5.02%	5	1.14%
A4095 (E)	191	276	-4	-2.14%	-5	-1.85%
A4095 (S)	388	532	2	0.51%	5	0.93%
TOTAL	1014	1083	21	2.03%	5	0.46%

Junction 22 - A4095/Bletchingdon Road

Approach	2031 Ref. Case		2031 With Dev Difference			
	AM	PM	AM		PM	
			Flow	% Impact	Flow	% Impact
A4095 (N)	546	563	16	2.85%	3	0.55%
Bletchingdon Rd	35	70	0	0.00%	1	1.41%
A4095 (SW)	565	687	1	0.18%	5	0.72%
TOTAL	1146	1320	17	1.46%	9	0.68%

Junction 23 - A4095/B4027

Approach	2031 Ref. Case		2031 With Dev Difference			
	AM	PM	AM		PM	
			Flow	% Impact	Flow	% Impact
A4095 (N)	393	458	9	2.24%	2	0.51%
B4027 (E)	65	505	0	0.00%	-2	-0.40%
A4095 (W)	1112	844	0	0.00%	2	0.24%
TOTAL	1570	1807	9	0.57%	2	0.11%

Junction 24 - A4095/B4027/unnamed rd

Approach	2031 Ref. Case		2031 With Dev Difference			
	AM	PM	AM		PM	
			Flow	% Impact	Flow	% Impact
A4095 (E)	458	963	9	1.93%	-1	-0.22%
A4095 (S)	469	592	0	0.00%	4	0.67%
B4027 (W)	934	305	0	0.00%	0	0.00%
TOTAL	1861	1860	9	0.48%	3	0.16%

Junction 25 - Camp Rd/Chilgrove Dr/Unnamed rd

Approach	2031 Ref. Case		2031 With Dev Difference			
	AM	PM	AM		PM	
			Flow	% Impact	Flow	% Impact
Chilgrove Dr	355	624	0	0.00%	5	0.79%
unnamed rd (E)	418	177	9	2.11%	20	10.15%
Camp Rd (S)	473	377	19	3.86%	39	9.38%
Camp Rd (W)	619	223	83	11.82%	26	10.44%
TOTAL	1865	1401	111	5.62%	90	6.04%

T19562
Heyford Park



Appendix D

Junctions 10 Output – Site Access/Camp Road

Junctions 10
PICADY 10 - Priority Intersection Module
Version: 10.0.2.1574 © Copyright TRL Software Limited, 2021
For sales and distribution information, program advice and maintenance, contact TRL Software: +44 (0)1344 379777 software@trl.co.uk trlsoftware.com
The users of this computer program for the solution of an engineering problem are in no way relieved of their responsibility for the correctness of the solution

Filename: T19562 - Site Access-Camp Road.j10
Path: C:\Users\JamesParker\Hub Transport Planning Ltd\Hub Transport Planning - General\Projects\T19562 Heyford Park\Junction Assessments\Picady
Report generation date: 17/12/2021 10:46:58

- »2031 + Development, AM
- »2031 + Development, PM

Summary of junction performance

	AM					PM				
	Set ID	Queue (PCU)	Delay (s)	RFC	LOS	Set ID	Queue (PCU)	Delay (s)	RFC	LOS
2031 + Development										
Stream B-AC	D1	0.4	11.66	0.29	B	D2	0.1	7.83	0.09	A
Stream C-AB		0.1	5.52	0.07	A		0.2	4.74	0.13	A

There are warnings associated with one or more model runs - see the 'Data Errors and Warnings' tables for each Analysis or Demand Set.

Values shown are the highest values encountered over all time segments. Delay is the maximum value of average delay per arriving vehicle.

File summary

File Description

Title	Site Access/Camp Road
Location	Heyford Park
Site number	
Date	19/11/2021
Version	
Status	(new file)
Identifier	
Client	Richborough Estates
Jobnumber	T19562
Enumerator	HUBTRANSPORTPLANNING\MaxLaw
Description	

Units

Distance units	Speed units	Traffic units input	Traffic units results	Flow units	Average delay units	Total delay units	Rate of delay units
m	kph	PCU	PCU	perHour	s	-Min	perMin

Analysis Options

Vehicle length (m)	Calculate Queue Percentiles	Calculate detailed queueing delay	Show lane queues in feet / metres	Show all PICADY stream intercepts	Calculate residual capacity	RFC Threshold	Average Delay threshold (s)	Queue threshold (PCU)	Use iterations with HCM roundabouts	Max number of iterations for roundabouts
5.75						0.85	36.00	20.00		500

Demand Set Summary

ID	Scenario name	Time Period name	Traffic profile type	Start time (HH:mm)	Finish time (HH:mm)	Time segment length (min)	Run automatically
D1	2031 + Development	AM	ONE HOUR	07:45	09:15	15	✓
D2	2031 + Development	PM	ONE HOUR	16:45	18:15	15	✓

Analysis Set Details

ID	Include in report	Network flow scaling factor (%)	Network capacity scaling factor (%)
A1	✓	100.000	100.000

2031 + Development, AM

Data Errors and Warnings

Severity	Area	Item	Description
Warning	Major arm width	Arm C - Major arm geometry	For two-way major roads, please interpret results with caution if the total major carriageway width is less than 8m.

Junction Network

Junctions

Junction	Name	Junction type	Arm A Direction	Arm B Direction	Arm C Direction	Use circulating lanes	Junction Delay (s)	Junction LOS
1	untitled	T-Junction	Two-way	Two-way	Two-way		1.58	A

Junction Network

Driving side	Lighting	Network delay (s)	Network LOS
Left	Normal/unknown	1.58	A

Arms

Arms

Arm	Name	Description	Arm type
A	untitled		Major
B	untitled		Minor
C	untitled		Major

Major Arm Geometry

Arm	Width of carriageway (m)	Has kerbed central reserve	Has right-turn storage	Visibility for right turn (m)	Blocks?	Blocking queue (PCU)
C	6.65			250.0	✓	0.00

Geometries for Arm C are measured opposite Arm B. Geometries for Arm A (if relevant) are measured opposite Arm D.

Minor Arm Geometry

Arm	Minor arm type	Lane width (m)	Visibility to left (m)	Visibility to right (m)
B	One lane	3.25	16	44

Slope / Intercept / Capacity

Priority Intersection Slopes and Intercepts

Stream	Intercept (PCU/hr)	Slope for A-B	Slope for A-C	Slope for C-A	Slope for C-B
B-A	517	0.098	0.242	0.152	0.345
B-C	668	0.104	0.263	-	-
C-B	719	0.283	0.283	-	-

The slopes and intercepts shown above include custom intercept adjustments only.

Streams may be combined, in which case capacity will be adjusted.

Values are shown for the first time segment only; they may differ for subsequent time segments.

Traffic Demand

Demand Set Details

ID	Scenario name	Time Period name	Traffic profile type	Start time (HH:mm)	Finish time (HH:mm)	Time segment length (min)	Run automatically
D1	2031 + Development	AM	ONE HOUR	07:45	09:15	15	✓

Vehicle mix varies over turn	Vehicle mix varies over entry	Vehicle mix source	PCU Factor for a HV (PCU)
✓	✓	HV Percentages	2.00

Demand overview (Traffic)

Arm	Linked arm	Profile type	Use O-D data	Average Demand (PCU/hr)	Scaling Factor (%)
A		ONE HOUR	✓	622	100.000
B		ONE HOUR	✓	113	100.000
C		ONE HOUR	✓	258	100.000

Origin-Destination Data

Demand (PCU/hr)

	To			
	A	B	C	
From	A	0	8	614
	B	24	0	89
	C	227	29	0

Vehicle Mix

Heavy Vehicle Percentages

	To			
	A	B	C	
From	A	0	1	0
	B	0	0	0
	C	0	0	0

Results

Results Summary for whole modelled period

Stream	Max RFC	Max Delay (s)	Max Queue (PCU)	Max LOS	Average Demand (PCU/hr)	Total Junction Arrivals (PCU)
B-AC	0.29	11.66	0.4	B	104	156
C-AB	0.07	5.52	0.1	A	39	58
C-A					198	295
A-B					7	11
A-C					583	845

2031 + Development, PM

Data Errors and Warnings

Severity	Area	Item	Description
Warning	Major arm width	Arm C - Major arm geometry	For two-way major roads, please interpret results with caution if the total major carriageway width is less than 8m.

Junction Network

Junctions

Junction	Name	Junction type	Arm A Direction	Arm B Direction	Arm C Direction	Use circulating lanes	Junction Delay (s)	Junction LOS
1	untitled	T-Junction	Two-way	Two-way	Two-way		1.14	A

Junction Network

Driving side	Lighting	Network delay (s)	Network LOS
Left	Normal/unknown	1.14	A

Traffic Demand

Demand Set Details

ID	Scenario name	Time Period name	Traffic profile type	Start time (HH:mm)	Finish time (HH:mm)	Time segment length (min)	Run automatically
D2	2031 + Development	PM	ONE HOUR	16:45	18:15	15	✓

Vehicle mix varies over turn	Vehicle mix varies over entry	Vehicle mix source	PCU Factor for a HV (PCU)
✓	✓	HV Percentages	2.00

Demand overview (Traffic)

Arm	Linked arm	Profile type	Use O-D data	Average Demand (PCU/hr)	Scaling Factor (%)
A		ONE HOUR	✓	246	100.000
B		ONE HOUR	✓	41	100.000
C		ONE HOUR	✓	393	100.000

Origin-Destination Data

Demand (PCU/hr)

		To		
		A	B	C
From	A	0	22	224
	B	13	0	28
	C	333	60	0

Vehicle Mix

Heavy Vehicle Percentages

		To		
		A	B	C
From	A	0	3	0
	B	0	0	0
	C	0	0	0

Results

Results Summary for whole modelled period

Stream	Max RFC	Max Delay (s)	Max Queue (PCU)	Max LOS	Average Demand (PCU/hr)	Total Junction Arrivals (PCU)
B-AC	0.09	7.83	0.1	A	38	58
C-AB	0.13	4.74	0.2	A	88	131
C-A					273	410
A-B					20	30
A-C					208	308

T19562
Heyford Park



Appendix E

LinSig Output – Camp Road/Chilgrove Drive

Full Input Data And Results

User and Project Details

Project:	Heyford Park
Title:	Camp Road/Chilgrove Drive Signalisation
Location:	
Client:	Richborough Estates
Site Ref(s):	T19562
Date Started:	24/11/2021
Additional detail:	
File name:	T19562 - Camp Road-Chilgrove Drive.lsg3x
Author:	Max law
Company:	Hub Transport Planning Lttd
Address:	Radclyffe House, 66/68 Hagley Road, Edgbaston, Birmingham, West Midlands, B16 8PF

Network Layout Diagram

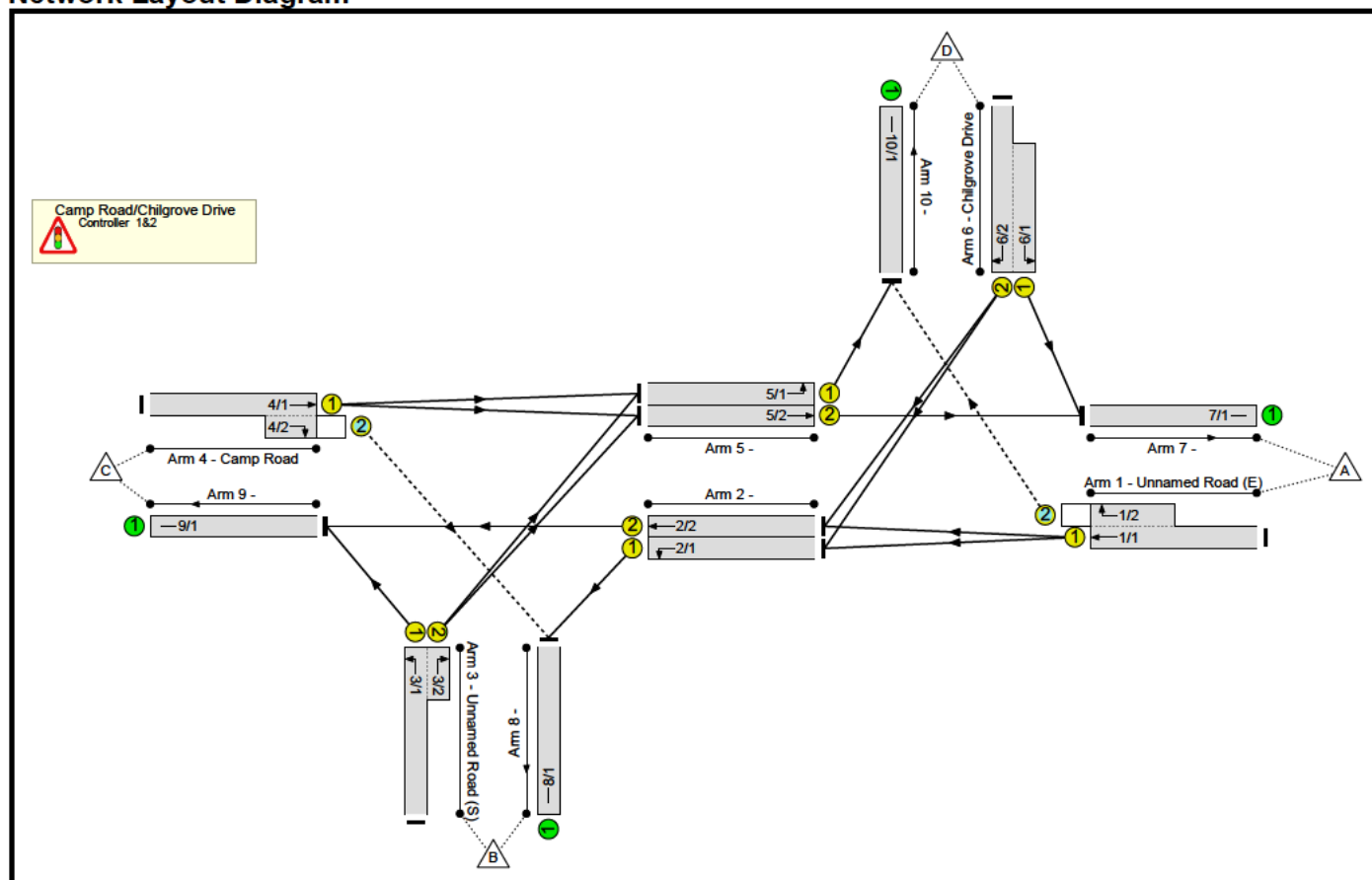

**C1
Phase Diagram**

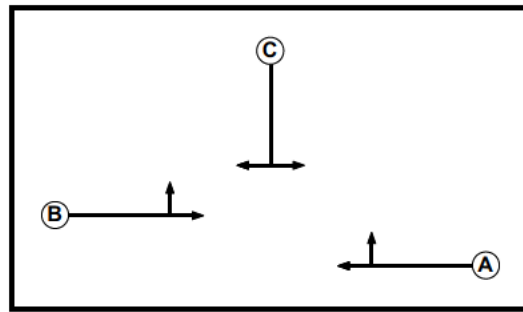

Phase Input Data

Phase Name	Phase Type	Assoc. Phase	Street Min	Cont Min
A	Traffic		7	7
B	Traffic		7	7
C	Traffic		7	7

Phase Intergreens Matrix

		Starting Phase		
		A	B	C
Terminating Phase	A			5
	B			6
	C	6	5	

Phases in Stage

Stage No.	Phases in Stage
1	A B
2	C

Stage Diagram

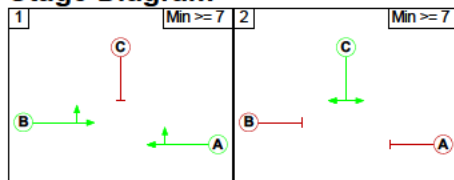

Phase Delays

Term. Stage	Start Stage	Phase	Type	Value	Cont value
There are no Phase Delays defined					

Prohibited Stage Change

		To Stage	
		1	2
From Stage	1		6
	2	6	

**C2
Phase Diagram**

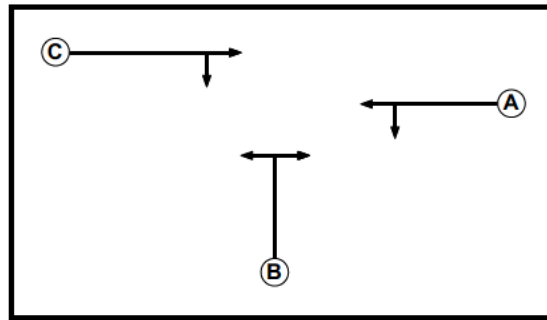

Phase Input Data

Phase Name	Phase Type	Assoc. Phase	Street Min	Cont Min
A	Traffic		7	7
B	Traffic		7	7
C	Traffic		7	7

Phase Intergreens Matrix

		Starting Phase		
		A	B	C
Terminating Phase	A		6	-
	B	6		6
	C	-	6	

Phases in Stage

Stage No.	Phases in Stage
1	A C
2	B

Stage Diagram

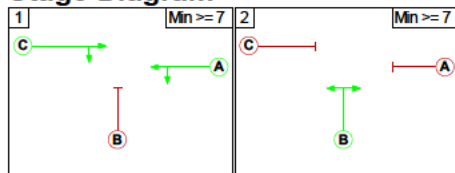

Phase Delays

Term. Stage	Start Stage	Phase	Type	Value	Cont value
There are no Phase Delays defined					

Prohibited Stage Change

		To Stage	
		1	2
From Stage	1		6
	2	6	

Give-Way Lane Input Data

Junction: Camp Road/Chilgrove Drive											
Lane	Movement	Max Flow when Giving Way (PCU/Hr)	Min Flow when Giving Way (PCU/Hr)	Opposing Lane	Opp. Lane Coeff.	Opp. Mvmnts.	Right Turn Storage (PCU)	Non-Blocking Storage (PCU)	RTF	Right Turn Move up (s)	Max Turns in Intergreen (PCU)
1/2 (Unnamed Road (E))	10/1 (Right)	1439	0	5/2	1.09	To 7/1 (Ahead)	2.00	-	0.50	2	2.00
				5/1	1.09	To 10/1 (Left)					
4/2 (Camp Road)	8/1 (Right)	1439	0	2/2	1.09	To 9/1 (Ahead)	2.00	-	0.50	2	2.00
				2/1	1.09	To 8/1 (Left)					

Lane Input Data

Junction: Camp Road/Chilgrove Drive												
Lane	Lane Type	Phases	Start Disp.	End Disp.	Physical Length (PCU)	Sat Flow Type	Def User Saturation Flow (PCU/Hr)	Lane Width (m)	Gradient	Nearside Lane	Turns	Turning Radius (m)
1/1 (Unnamed Road (E))	U	A	2	3	60.0	Geom	-	3.50	0.00	Y	Arm 2 Ahead	Inf
1/2 (Unnamed Road (E))	O	A	2	3	5.7	Geom	-	3.50	0.00	Y	Arm 10 Right	15.00
2/1	U	A	2	3	8.7	Geom	-	3.50	0.00	Y	Arm 8 Left	10.00
2/2	U	A	2	3	8.7	Geom	-	3.50	0.00	Y	Arm 9 Ahead	Inf
3/1 (Unnamed Road (S))	U	B	2	3	60.0	Geom	-	3.50	0.00	Y	Arm 9 Left	10.00
3/2 (Unnamed Road (S))	U	B	2	3	3.5	Geom	-	3.50	0.00	Y	Arm 5 Right	15.00
4/1 (Camp Road)	U	C	2	3	60.0	Geom	-	3.50	0.00	Y	Arm 5 Ahead	Inf
4/2 (Camp Road)	O	C	2	3	3.5	Geom	-	3.50	0.00	Y	Arm 8 Right	15.00
5/1	U	B	2	3	8.7	Geom	-	3.50	0.00	Y	Arm 10 Left	10.00
5/2	U	B	2	3	8.7	Geom	-	3.50	0.00	Y	Arm 7 Ahead	Inf
6/1 (Chilgrove Drive)	U	C	2	3	8.7	Geom	-	3.50	0.00	Y	Arm 7 Left	10.00
6/2 (Chilgrove Drive)	U	C	2	3	60.0	Geom	-	3.50	0.00	Y	Arm 2 Right	15.00
7/1	U		2	3	60.0	Inf	-	-	-	-	-	-
8/1	U		2	3	60.0	Inf	-	-	-	-	-	-
9/1	U		2	3	60.0	Inf	-	-	-	-	-	-
10/1	U		2	3	60.0	Inf	-	-	-	-	-	-

Traffic Flow Groups

Flow Group	Start Time	End Time	Duration	Formula
1: '2031 Reference Case AM'	08:00	09:00	01:00	
2: '2031 Reference Case PM'	17:00	18:00	01:00	
3: '2031 Reference Case + Development AM'	08:00	09:00	01:00	
4: '2031 Reference Case + Development PM'	17:00	18:00	01:00	

Scenario 1: '2031 Reference Case AM' (FG1: '2031 Reference Case AM', Plan 1: 'Network Control Plan 1')

Traffic Flows, Desired

Desired Flow :

	Destination					Tot.
	A	B	C	D		
Origin	A	0	0	69	349	418
	B	26	0	149	298	473
	C	545	6	0	68	619
	D	316	23	16	0	355
	Tot.	887	29	234	715	1865

Traffic Lane Flows

Lane	Scenario 1: 2031 Reference Case AM
Junction: Camp Road/Chilgrove Drive	
1/1 (with short)	418(In) 69(Out)
1/2 (short)	349
2/1	23
2/2	85
3/1 (with short)	473(In) 149(Out)
3/2 (short)	324
4/1 (with short)	619(In) 613(Out)
4/2 (short)	6
5/1	366
5/2	571
6/1 (short)	316
6/2 (with short)	355(In) 39(Out)
7/1	887
8/1	29
9/1	234
10/1	715

Lane Saturation Flows

Junction: Camp Road/Chilgrove Drive								
Lane	Lane Width (m)	Gradient	Nearside Lane	Allowed Turns	Turning Radius (m)	Turning Prop.	Sat Flow (PCU/Hr)	Flared Sat Flow (PCU/Hr)
1/1 (Unnamed Road (E))	3.50	0.00	Y	Arm 2 Ahead	Inf	100.0 %	1965	1965
1/2 (Unnamed Road (E))	3.50	0.00	Y	Arm 10 Right	15.00	100.0 %	1786	1786
2/1	3.50	0.00	Y	Arm 8 Left	10.00	100.0 %	1709	1709
2/2	3.50	0.00	Y	Arm 9 Ahead	Inf	100.0 %	1965	1965
3/1 (Unnamed Road (S))	3.50	0.00	Y	Arm 9 Left	10.00	100.0 %	1709	1709
3/2 (Unnamed Road (S))	3.50	0.00	Y	Arm 5 Right	15.00	100.0 %	1786	1786
4/1 (Camp Road)	3.50	0.00	Y	Arm 5 Ahead	Inf	100.0 %	1965	1965
4/2 (Camp Road)	3.50	0.00	Y	Arm 8 Right	15.00	100.0 %	1786	1786
5/1	3.50	0.00	Y	Arm 10 Left	10.00	100.0 %	1709	1709
5/2	3.50	0.00	Y	Arm 7 Ahead	Inf	100.0 %	1965	1965
6/1 (Chilgrove Drive)	3.50	0.00	Y	Arm 7 Left	10.00	100.0 %	1709	1709
6/2 (Chilgrove Drive)	3.50	0.00	Y	Arm 2 Right	15.00	100.0 %	1786	1786
7/1	Infinite Saturation Flow						Inf	Inf
8/1	Infinite Saturation Flow						Inf	Inf
9/1	Infinite Saturation Flow						Inf	Inf
10/1	Infinite Saturation Flow						Inf	Inf

Scenario 2: '2031 Reference Case PM' (FG2: '2031 Reference Case PM', Plan 1: 'Network Control Plan 1')
Traffic Flows, Desired

Desired Flow :

	Destination					
	A	B	C	D	Tot.	
Origin	A	0	1	76	100	177
	B	13	0	193	171	377
	C	203	3	0	17	223
	D	511	51	62	0	624
	Tot.	727	55	331	288	1401

Traffic Lane Flows

Lane	Scenario 2: 2031 Reference Case PM
Junction: Camp Road/Chilgrove Drive	
1/1 (with short)	177(In) 77(Out)
1/2 (short)	100
2/1	52
2/2	138
3/1 (with short)	377(In) 193(Out)
3/2 (short)	184
4/1 (with short)	223(In) 220(Out)
4/2 (short)	3
5/1	188
5/2	216
6/1 (short)	511
6/2 (with short)	624(In) 113(Out)
7/1	727
8/1	55
9/1	331
10/1	288

Lane Saturation Flows

Junction: Camp Road/Chilgrove Drive								
Lane	Lane Width (m)	Gradient	Nearside Lane	Allowed Turns	Turning Radius (m)	Turning Prop.	Sat Flow (PCU/Hr)	Flared Sat Flow (PCU/Hr)
1/1 (Unnamed Road (E))	3.50	0.00	Y	Arm 2 Ahead	Inf	100.0 %	1965	1965
1/2 (Unnamed Road (E))	3.50	0.00	Y	Arm 10 Right	15.00	100.0 %	1786	1786
2/1	3.50	0.00	Y	Arm 8 Left	10.00	100.0 %	1709	1709
2/2	3.50	0.00	Y	Arm 9 Ahead	Inf	100.0 %	1965	1965
3/1 (Unnamed Road (S))	3.50	0.00	Y	Arm 9 Left	10.00	100.0 %	1709	1709
3/2 (Unnamed Road (S))	3.50	0.00	Y	Arm 5 Right	15.00	100.0 %	1786	1786
4/1 (Camp Road)	3.50	0.00	Y	Arm 5 Ahead	Inf	100.0 %	1965	1965
4/2 (Camp Road)	3.50	0.00	Y	Arm 8 Right	15.00	100.0 %	1786	1786
5/1	3.50	0.00	Y	Arm 10 Left	10.00	100.0 %	1709	1709
5/2	3.50	0.00	Y	Arm 7 Ahead	Inf	100.0 %	1965	1965
6/1 (Chilgrove Drive)	3.50	0.00	Y	Arm 7 Left	10.00	100.0 %	1709	1709
6/2 (Chilgrove Drive)	3.50	0.00	Y	Arm 2 Right	15.00	100.0 %	1786	1786
7/1	Infinite Saturation Flow						Inf	Inf
8/1	Infinite Saturation Flow						Inf	Inf
9/1	Infinite Saturation Flow						Inf	Inf
10/1	Infinite Saturation Flow						Inf	Inf

Scenario 3: '2031 Reference Case + Development AM' (FG3: '2031 Reference Case + Development AM', Plan 1: 'Network Control Plan 1')

Traffic Flows, Desired

Desired Flow :

	Destination					Tot.
	A	B	C	D		
Origin	A	0	0	76	351	427
	B	26	0	164	302	492
	C	599	27	0	76	702
	D	315	23	17	0	355
	Tot.	940	50	257	729	1976

Traffic Lane Flows

Lane	Scenario 3: 2031 Reference Case + Development AM
Junction: Camp Road/Chilgrove Drive	
1/1 (with short)	427(In) 76(Out)
1/2 (short)	351
2/1	23
2/2	93
3/1 (with short)	492(In) 164(Out)
3/2 (short)	328
4/1 (with short)	702(In) 675(Out)
4/2 (short)	27
5/1	378
5/2	625
6/1 (short)	315
6/2 (with short)	355(In) 40(Out)
7/1	940
8/1	50
9/1	257
10/1	729

Lane Saturation Flows

Junction: Camp Road/Chilgrove Drive								
Lane	Lane Width (m)	Gradient	Nearside Lane	Allowed Turns	Turning Radius (m)	Turning Prop.	Sat Flow (PCU/Hr)	Flared Sat Flow (PCU/Hr)
1/1 (Unnamed Road (E))	3.50	0.00	Y	Arm 2 Ahead	Inf	100.0 %	1965	1965
1/2 (Unnamed Road (E))	3.50	0.00	Y	Arm 10 Right	15.00	100.0 %	1786	1786
2/1	3.50	0.00	Y	Arm 8 Left	10.00	100.0 %	1709	1709
2/2	3.50	0.00	Y	Arm 9 Ahead	Inf	100.0 %	1965	1965
3/1 (Unnamed Road (S))	3.50	0.00	Y	Arm 9 Left	10.00	100.0 %	1709	1709
3/2 (Unnamed Road (S))	3.50	0.00	Y	Arm 5 Right	15.00	100.0 %	1786	1786
4/1 (Camp Road)	3.50	0.00	Y	Arm 5 Ahead	Inf	100.0 %	1965	1965
4/2 (Camp Road)	3.50	0.00	Y	Arm 8 Right	15.00	100.0 %	1786	1786
5/1	3.50	0.00	Y	Arm 10 Left	10.00	100.0 %	1709	1709
5/2	3.50	0.00	Y	Arm 7 Ahead	Inf	100.0 %	1965	1965
6/1 (Chilgrove Drive)	3.50	0.00	Y	Arm 7 Left	10.00	100.0 %	1709	1709
6/2 (Chilgrove Drive)	3.50	0.00	Y	Arm 2 Right	15.00	100.0 %	1786	1786
7/1	Infinite Saturation Flow						Inf	Inf
8/1	Infinite Saturation Flow						Inf	Inf
9/1	Infinite Saturation Flow						Inf	Inf
10/1	Infinite Saturation Flow						Inf	Inf

Scenario 4: '2031 Reference Case + Development PM' (FG4: '2031 Reference Case + Development PM', Plan 1: 'Network Control Plan 1')

Traffic Flows, Desired

Desired Flow :

	Destination					Tot.
	A	B	C	D		
Origin	A	0	1	94	102	197
	B	13	0	233	170	416
	C	224	7	0	18	249
	D	511	51	67	0	629
	Tot.	748	59	394	290	1491

Traffic Lane Flows

Lane	Scenario 4: 2031 Reference Case + Development PM
Junction: Camp Road/Chilgrove Drive	
1/1 (with short)	197(In) 95(Out)
1/2 (short)	102
2/1	52
2/2	161
3/1 (with short)	416(In) 233(Out)
3/2 (short)	183
4/1 (with short)	249(In) 242(Out)
4/2 (short)	7
5/1	188
5/2	237
6/1 (short)	511
6/2 (with short)	629(In) 118(Out)
7/1	748
8/1	59
9/1	394
10/1	290

Lane Saturation Flows

Junction: Camp Road/Chilgrove Drive								
Lane	Lane Width (m)	Gradient	Nearside Lane	Allowed Turns	Turning Radius (m)	Turning Prop.	Sat Flow (PCU/Hr)	Flared Sat Flow (PCU/Hr)
1/1 (Unnamed Road (E))	3.50	0.00	Y	Arm 2 Ahead	Inf	100.0 %	1965	1965
1/2 (Unnamed Road (E))	3.50	0.00	Y	Arm 10 Right	15.00	100.0 %	1786	1786
2/1	3.50	0.00	Y	Arm 8 Left	10.00	100.0 %	1709	1709
2/2	3.50	0.00	Y	Arm 9 Ahead	Inf	100.0 %	1965	1965
3/1 (Unnamed Road (S))	3.50	0.00	Y	Arm 9 Left	10.00	100.0 %	1709	1709
3/2 (Unnamed Road (S))	3.50	0.00	Y	Arm 5 Right	15.00	100.0 %	1786	1786
4/1 (Camp Road)	3.50	0.00	Y	Arm 5 Ahead	Inf	100.0 %	1965	1965
4/2 (Camp Road)	3.50	0.00	Y	Arm 8 Right	15.00	100.0 %	1786	1786
5/1	3.50	0.00	Y	Arm 10 Left	10.00	100.0 %	1709	1709
5/2	3.50	0.00	Y	Arm 7 Ahead	Inf	100.0 %	1965	1965
6/1 (Chilgrove Drive)	3.50	0.00	Y	Arm 7 Left	10.00	100.0 %	1709	1709
6/2 (Chilgrove Drive)	3.50	0.00	Y	Arm 2 Right	15.00	100.0 %	1786	1786
7/1	Infinite Saturation Flow						Inf	Inf
8/1	Infinite Saturation Flow						Inf	Inf
9/1	Infinite Saturation Flow						Inf	Inf
10/1	Infinite Saturation Flow						Inf	Inf

Scenario 1: '2031 Reference Case AM' (FG1: '2031 Reference Case AM', Plan 1: 'Network Control Plan 1')
C1

Stage Sequence Diagram

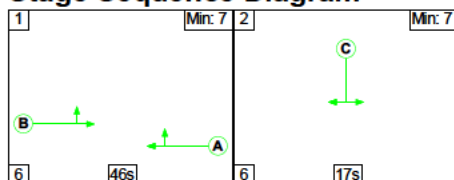

Stage Timings

Stage	1	2
Duration	46	17
Change Point	0	52

Signal Timings Diagram

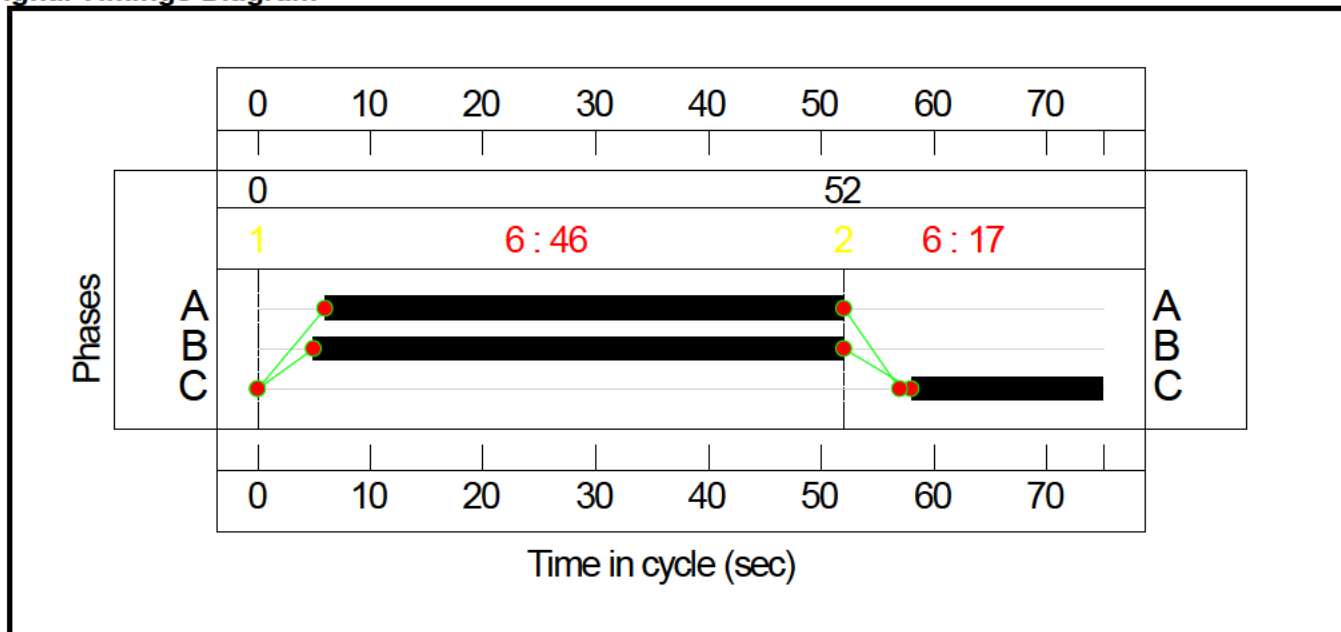

C2 Stage Sequence Diagram

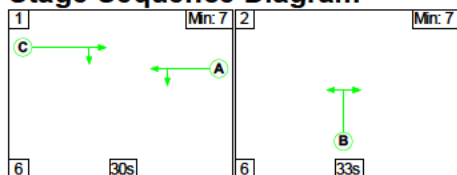

Stage Timings

Stage	1	2
Duration	30	33
Change Point	28	64

Signal Timings Diagram

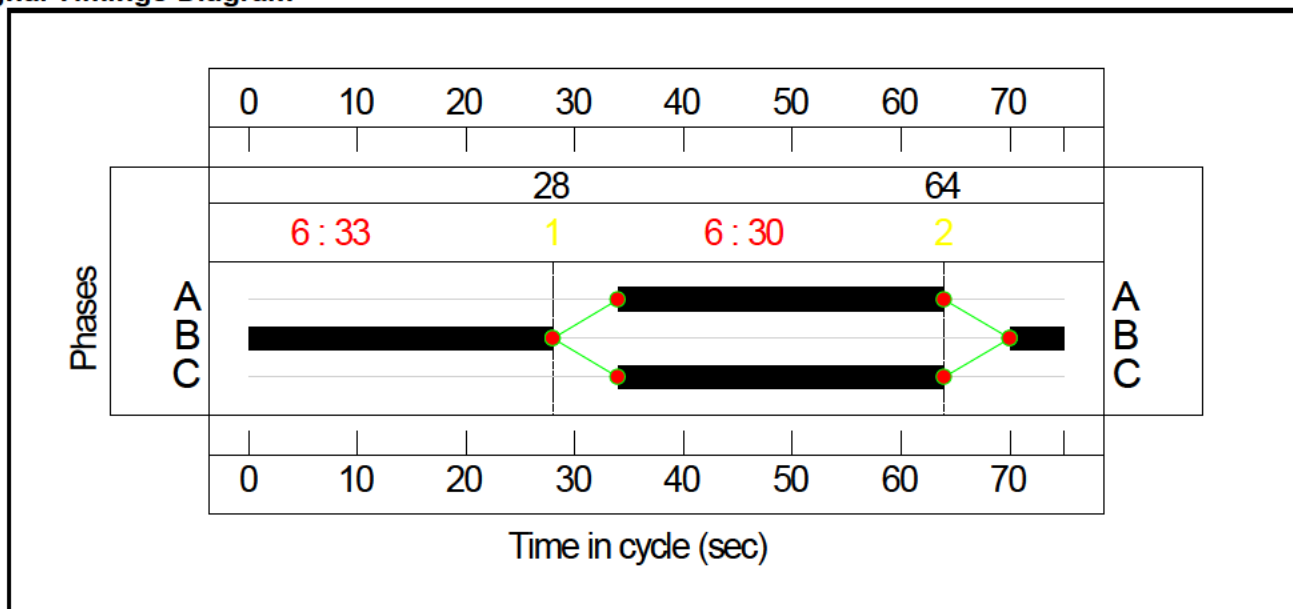

Network Layout Diagram

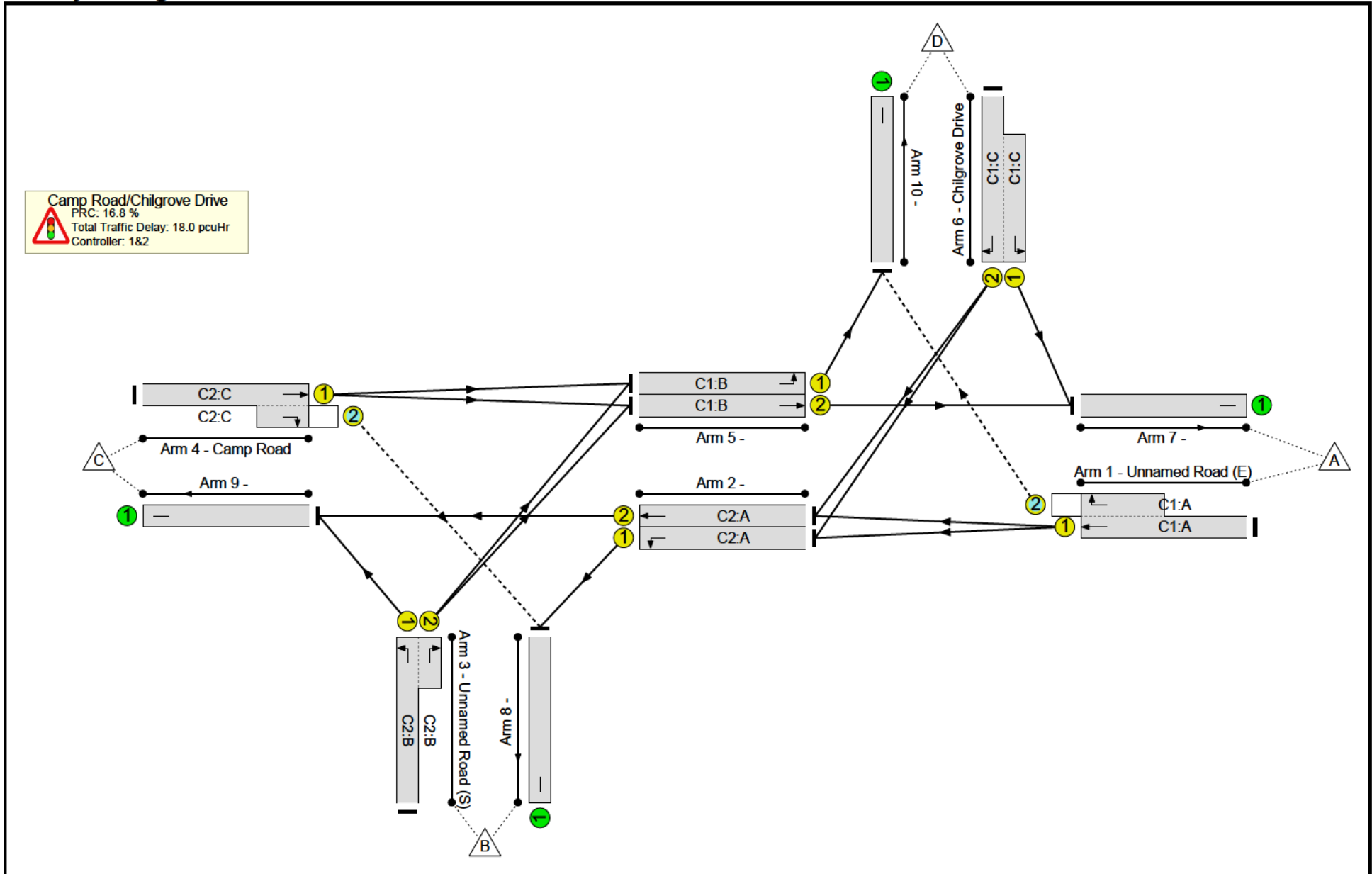

Network Results

Item	Lane Description	Lane Type	Controller Stream	Position In Filtered Route	Full Phase	Arrow Phase	Num Greens	Total Green (s)	Arrow Green (s)	Demand Flow (pcu)	Sat Flow (pcu/Hr)	Capacity (pcu)	Deg Sat (%)
Network: Camp Road/Chilgrove Drive Signalisation	-	-	N/A	-	-		-	-	-	-	-	-	77.0%
Camp Road/Chilgrove Drive	-	-	N/A	-	-		-	-	-	-	-	-	77.0%
1/1+1/2	Unnamed Road (E) Ahead Right	U+O	N/A	N/A	C1:A		1	46	-	418	1965:1786	90+454	76.9 : 76.9%
2/1	Left	U	N/A	N/A	C2:A		1	30	-	23	1709	706	3.3%
2/2	Ahead	U	N/A	N/A	C2:A		1	30	-	85	1965	812	10.5%
3/1+3/2	Unnamed Road (S) Right Left	U	N/A	N/A	C2:B		1	33	-	473	1709:1786	281+612	53.0 : 53.0%
4/1+4/2	Camp Road Ahead Right	U+O	N/A	N/A	C2:C		1	30	-	619	1965:1786	812+8	75.5 : 75.5%
5/1	Left	U	N/A	N/A	C1:B		1	47	-	366	1709	1094	33.5%
5/2	Ahead	U	N/A	N/A	C1:B		1	47	-	571	1965	1258	45.4%
6/2+6/1	Chilgrove Drive Right Left	U	N/A	N/A	C1:C		1	17	-	355	1786:1709	51+410	77.0 : 77.0%
7/1		U	N/A	N/A	-		-	-	-	887	Inf	Inf	0.0%
8/1		U	N/A	N/A	-		-	-	-	29	Inf	Inf	0.0%
9/1		U	N/A	N/A	-		-	-	-	234	Inf	Inf	0.0%
10/1		U	N/A	N/A	-		-	-	-	715	Inf	Inf	0.0%

Item	Arriving (pcu)	Leaving (pcu)	Turners In Gaps (pcu)	Turners When Unopposed (pcu)	Turners In Intergreen (pcu)	Uniform Delay (pcuHr)	Rand + Oversat Delay (pcuHr)	Storage Area Uniform Delay (pcuHr)	Total Delay (pcuHr)	Av. Delay Per PCU (s/pcu)	Max. Back of Uniform Queue (pcu)	Rand + Oversat Queue (pcu)	Mean Max Queue (pcu)																					
Network: Camp Road/Chilgrove Drive Signalisation	-	-	297	0	58	11.3	6.1	0.6	18.0	-	-	-	-																					
Camp Road/Chilgrove Drive	-	-	297	0	58	11.3	6.1	0.6	18.0	-	-	-	-																					
1/1+1/2	418	418	291	0	58	1.0	1.6	0.6	3.2	27.8	4.8	1.6	6.4																					
2/1	23	23	-	-	-	0.1	0.0	-	0.2	25.2	0.3	0.0	0.3																					
2/2	85	85	-	-	-	0.3	0.1	-	0.4	16.2	1.2	0.1	1.2																					
3/1+3/2	473	473	-	-	-	1.8	0.6	-	2.3	17.7	5.0	0.6	5.5																					
4/1+4/2	619	619	6	0	0	3.2	1.5	0.0	4.7	27.6	10.7	1.5	12.2																					
5/1	366	366	-	-	-	0.4	0.3	-	0.7	6.9	5.1	0.3	5.4																					
5/2	571	571	-	-	-	1.8	0.4	-	2.3	14.3	5.8	0.4	6.2																					
6/2+6/1	355	355	-	-	-	2.6	1.6	-	4.2	42.6	6.1	1.6	7.7																					
7/1	887	887	-	-	-	0.0	0.0	-	0.0	0.0	0.0	0.0	0.0																					
8/1	29	29	-	-	-	0.0	0.0	-	0.0	0.0	0.0	0.0	0.0																					
9/1	234	234	-	-	-	0.0	0.0	-	0.0	0.0	0.0	0.0	0.0																					
10/1	715	715	-	-	-	0.0	0.0	-	0.0	0.0	0.0	0.0	0.0																					
<table style="width:100%; border:none;"> <tr> <td style="width:15%;">C1</td> <td style="width:15%;">PRC for Signalled Lanes (%):</td> <td style="width:15%;">16.8</td> <td style="width:15%;">Total Delay for Signalled Lanes (pcuHr):</td> <td style="width:15%;">10.40</td> <td style="width:15%;">Cycle Time (s):</td> <td style="width:15%;">75</td> </tr> <tr> <td>C2</td> <td>PRC for Signalled Lanes (%):</td> <td>19.2</td> <td>Total Delay for Signalled Lanes (pcuHr):</td> <td>7.61</td> <td>Cycle Time (s):</td> <td>75</td> </tr> <tr> <td></td> <td>PRC Over All Lanes (%):</td> <td>16.8</td> <td>Total Delay Over All Lanes(pcuHr):</td> <td>18.00</td> <td></td> <td></td> </tr> </table>														C1	PRC for Signalled Lanes (%):	16.8	Total Delay for Signalled Lanes (pcuHr):	10.40	Cycle Time (s):	75	C2	PRC for Signalled Lanes (%):	19.2	Total Delay for Signalled Lanes (pcuHr):	7.61	Cycle Time (s):	75		PRC Over All Lanes (%):	16.8	Total Delay Over All Lanes(pcuHr):	18.00		
C1	PRC for Signalled Lanes (%):	16.8	Total Delay for Signalled Lanes (pcuHr):	10.40	Cycle Time (s):	75																												
C2	PRC for Signalled Lanes (%):	19.2	Total Delay for Signalled Lanes (pcuHr):	7.61	Cycle Time (s):	75																												
	PRC Over All Lanes (%):	16.8	Total Delay Over All Lanes(pcuHr):	18.00																														

Scenario 2: '2031 Reference Case PM' (FG2: '2031 Reference Case PM', Plan 1: 'Network Control Plan 1')

C1

Stage Sequence Diagram

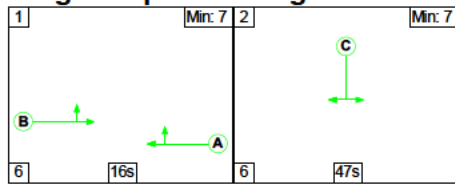

Stage Timings

Stage	1	2
Duration	16	47
Change Point	0	22

Signal Timings Diagram

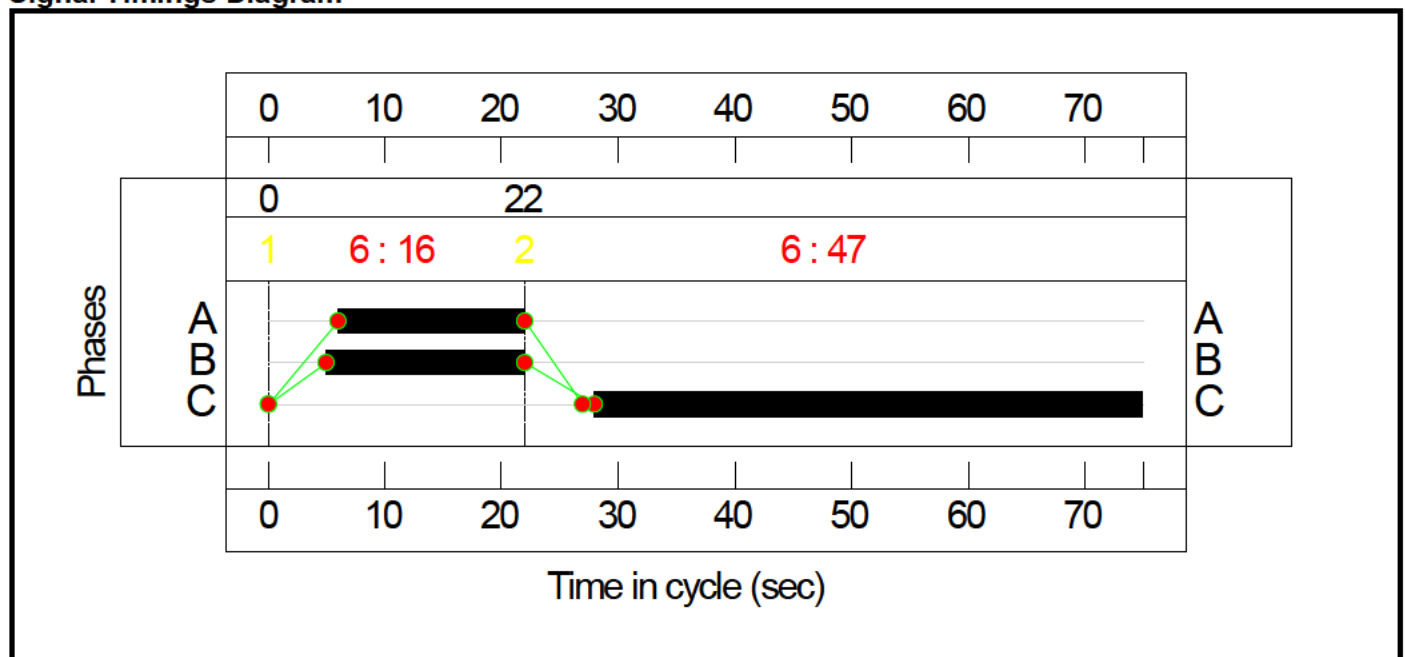

C2

Stage Sequence Diagram

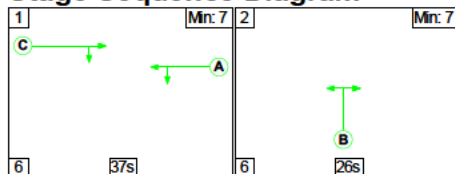

Stage Timings

Stage	1	2
Duration	37	26
Change Point	27	70

Signal Timings Diagram

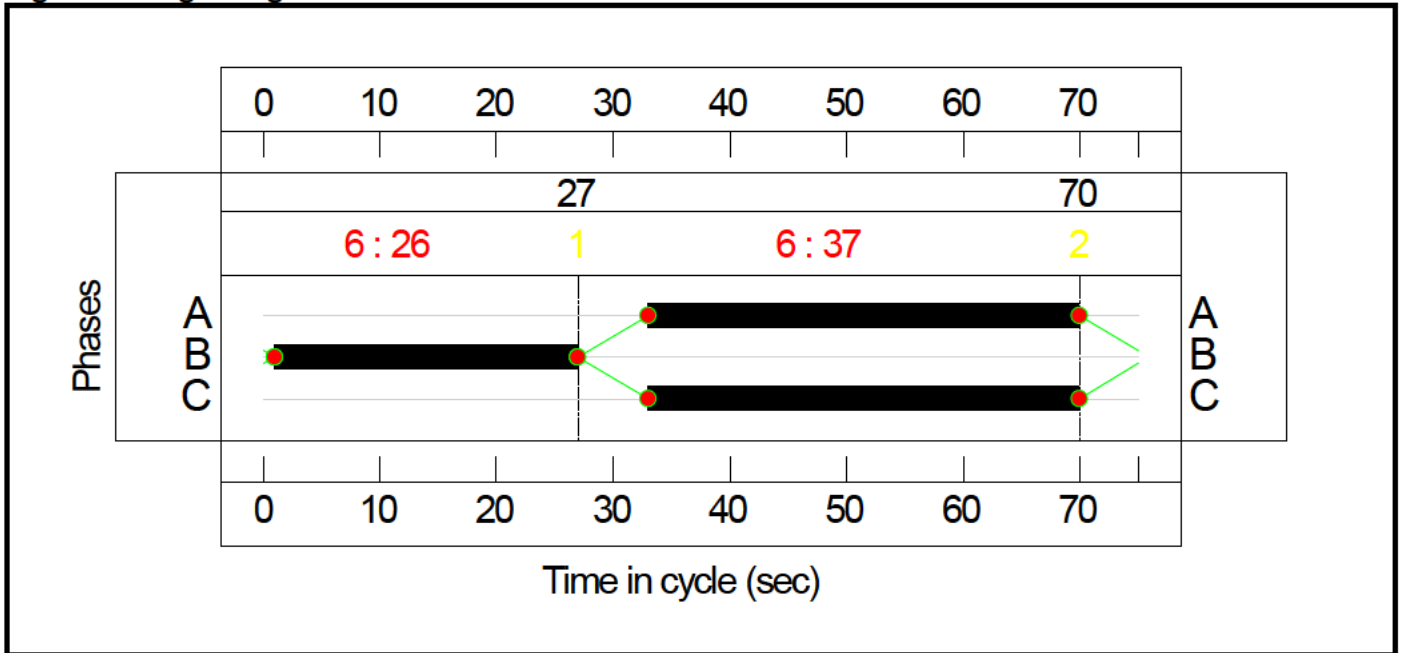

Network Layout Diagram

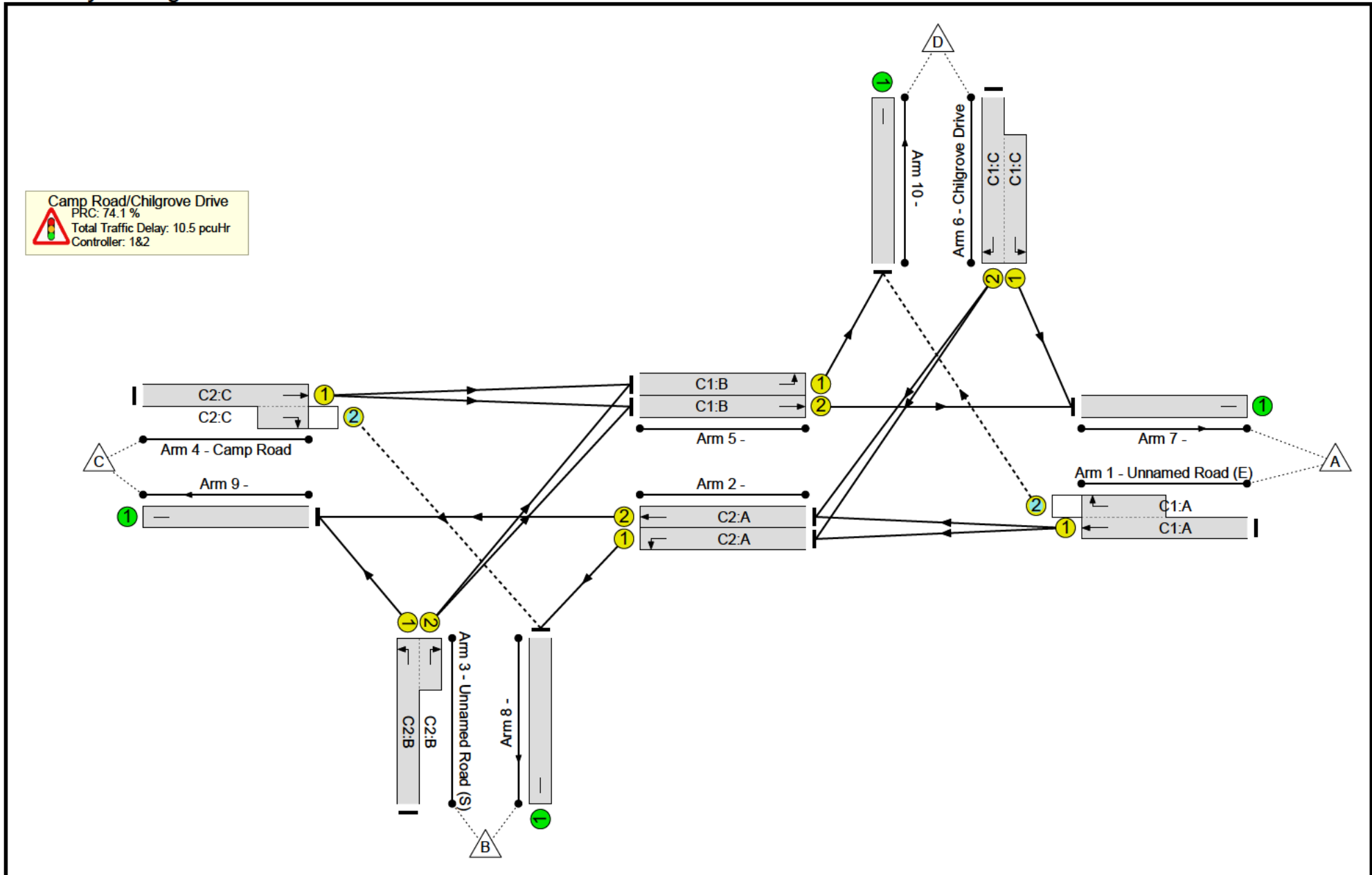

Network Results

Item	Lane Description	Lane Type	Controller Stream	Position In Filtered Route	Full Phase	Arrow Phase	Num Greens	Total Green (s)	Arrow Green (s)	Demand Flow (pcu)	Sat Flow (pcu/Hr)	Capacity (pcu)	Deg Sat (%)
Network: Camp Road/Chilgrove Drive Signalisation	-	-	N/A	-	-		-	-	-	-	-	-	51.7%
Camp Road/Chilgrove Drive	-	-	N/A	-	-		-	-	-	-	-	-	51.7%
1/1+1/2	Unnamed Road (E) Ahead Right	U+O	N/A	N/A	C1:A		1	16	-	177	1965:1786	158+205	48.7 : 48.7%
2/1	Left	U	N/A	N/A	C2:A		1	37	-	52	1709	866	6.0%
2/2	Ahead	U	N/A	N/A	C2:A		1	37	-	138	1965	996	13.9%
3/1+3/2	Unnamed Road (S) Right Left	U	N/A	N/A	C2:B		1	26	-	377	1709:1786	414+395	46.6 : 46.6%
4/1+4/2	Camp Road Ahead Right	U+O	N/A	N/A	C2:C		1	37	-	223	1965:1786	996+14	22.1 : 22.1%
5/1	Left	U	N/A	N/A	C1:B		1	17	-	188	1709	410	45.8%
5/2	Ahead	U	N/A	N/A	C1:B		1	17	-	216	1965	472	45.8%
6/2+6/1	Chilgrove Drive Right Left	U	N/A	N/A	C1:C		1	47	-	624	1786:1709	219+988	51.7 : 51.7%
7/1		U	N/A	N/A	-		-	-	-	727	Inf	Inf	0.0%
8/1		U	N/A	N/A	-		-	-	-	55	Inf	Inf	0.0%
9/1		U	N/A	N/A	-		-	-	-	331	Inf	Inf	0.0%
10/1		U	N/A	N/A	-		-	-	-	288	Inf	Inf	0.0%

Item	Arriving (pcu)	Leaving (pcu)	Turners In Gaps (pcu)	Turners When Unopposed (pcu)	Turners In Intergreen (pcu)	Uniform Delay (pcuHr)	Rand + Oversat Delay (pcuHr)	Storage Area Uniform Delay (pcuHr)	Total Delay (pcuHr)	Av. Delay Per PCU (s/pcu)	Max. Back of Uniform Queue (pcu)	Rand + Oversat Queue (pcu)	Mean Max Queue (pcu)																								
Network: Camp Road/Chilgrove Drive Signalisation	-	-	103	0	0	7.8	2.5	0.2	10.5	-	-	-	-																								
Camp Road/Chilgrove Drive	-	-	103	0	0	7.8	2.5	0.2	10.5	-	-	-	-																								
1/1+1/2	177	177	100	0	0	1.2	0.5	0.2	1.9	37.7	1.7	0.5	2.2																								
2/1	52	52	-	-	-	0.1	0.0	-	0.1	7.4	0.2	0.0	0.2																								
2/2	138	138	-	-	-	0.5	0.1	-	0.6	15.1	2.2	0.1	2.3																								
3/1+3/2	377	377	-	-	-	1.8	0.4	-	2.2	21.4	2.9	0.4	3.3																								
4/1+4/2	223	223	3	0	0	0.6	0.1	0.0	0.8	12.6	2.5	0.1	2.6																								
5/1	188	188	-	-	-	0.5	0.4	-	1.0	18.3	1.1	0.4	1.5																								
5/2	216	216	-	-	-	1.9	0.4	-	2.3	39.0	4.4	0.4	4.9																								
6/2+6/1	624	624	-	-	-	1.1	0.5	-	1.7	9.7	5.4	0.5	5.9																								
7/1	727	727	-	-	-	0.0	0.0	-	0.0	0.0	0.0	0.0	0.0																								
8/1	55	55	-	-	-	0.0	0.0	-	0.0	0.0	0.0	0.0	0.0																								
9/1	331	331	-	-	-	0.0	0.0	-	0.0	0.0	0.0	0.0	0.0																								
10/1	288	288	-	-	-	0.0	0.0	-	0.0	0.0	0.0	0.0	0.0																								
<table style="width:100%; border:none;"> <tr> <td style="width:15%;"></td> <td style="width:10%;">C1</td> <td style="width:15%;">PRC for Signalled Lanes (%):</td> <td style="width:10%;">74.1</td> <td style="width:15%;">Total Delay for Signalled Lanes (pcuHr):</td> <td style="width:10%;">6.83</td> <td style="width:15%;">Cycle Time (s):</td> <td style="width:10%;">75</td> </tr> <tr> <td></td> <td>C2</td> <td>PRC for Signalled Lanes (%):</td> <td>93.1</td> <td>Total Delay for Signalled Lanes (pcuHr):</td> <td>3.71</td> <td>Cycle Time (s):</td> <td>75</td> </tr> <tr> <td></td> <td></td> <td>PRC Over All Lanes (%):</td> <td>74.1</td> <td>Total Delay Over All Lanes(pcuHr):</td> <td>10.54</td> <td></td> <td></td> </tr> </table>															C1	PRC for Signalled Lanes (%):	74.1	Total Delay for Signalled Lanes (pcuHr):	6.83	Cycle Time (s):	75		C2	PRC for Signalled Lanes (%):	93.1	Total Delay for Signalled Lanes (pcuHr):	3.71	Cycle Time (s):	75			PRC Over All Lanes (%):	74.1	Total Delay Over All Lanes(pcuHr):	10.54		
	C1	PRC for Signalled Lanes (%):	74.1	Total Delay for Signalled Lanes (pcuHr):	6.83	Cycle Time (s):	75																														
	C2	PRC for Signalled Lanes (%):	93.1	Total Delay for Signalled Lanes (pcuHr):	3.71	Cycle Time (s):	75																														
		PRC Over All Lanes (%):	74.1	Total Delay Over All Lanes(pcuHr):	10.54																																

Scenario 3: '2031 Reference Case + Development AM' (FG3: '2031 Reference Case + Development AM', Plan 1: 'Network Control Plan 1')

C1

Stage Sequence Diagram

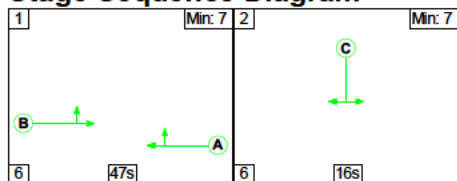

Stage Timings

Stage	1	2
Duration	47	16
Change Point	0	53

Signal Timings Diagram

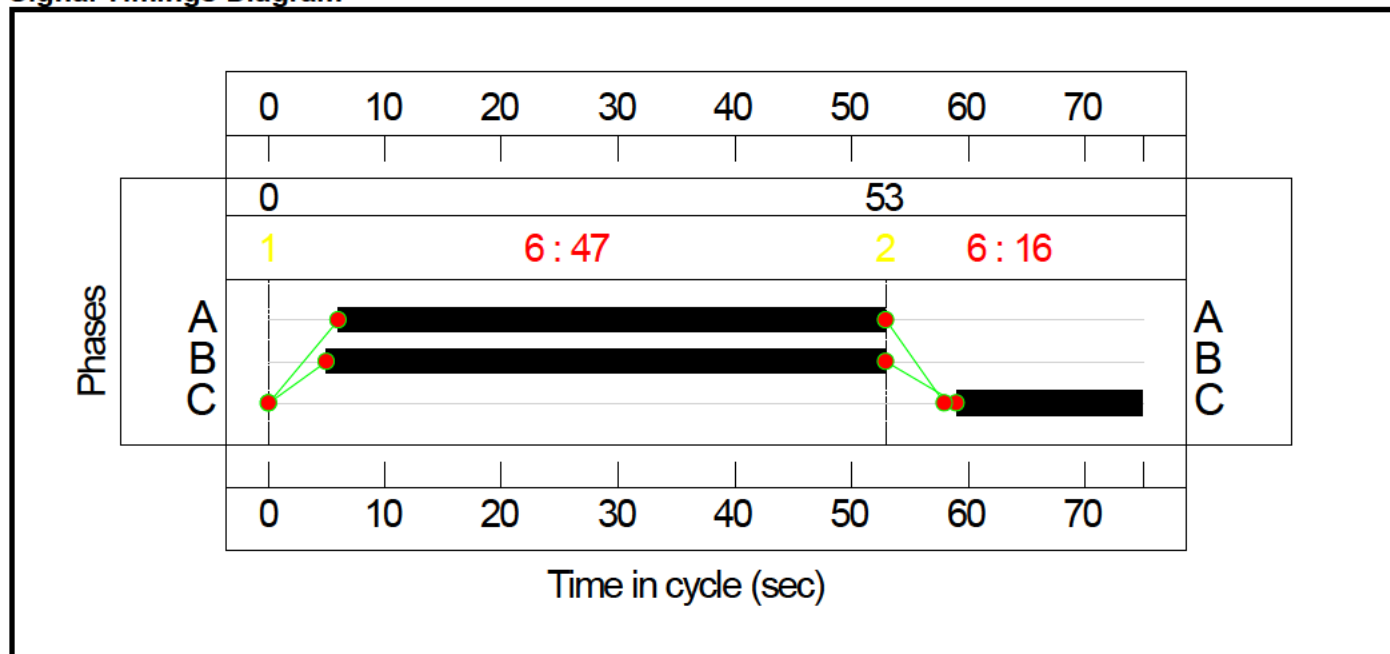

C2

Stage Sequence Diagram

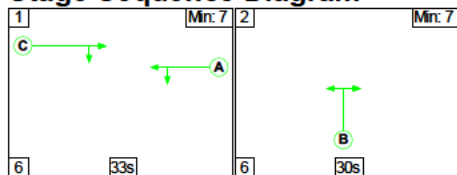

Stage Timings

Stage	1	2
Duration	33	30
Change Point	28	67

Signal Timings Diagram

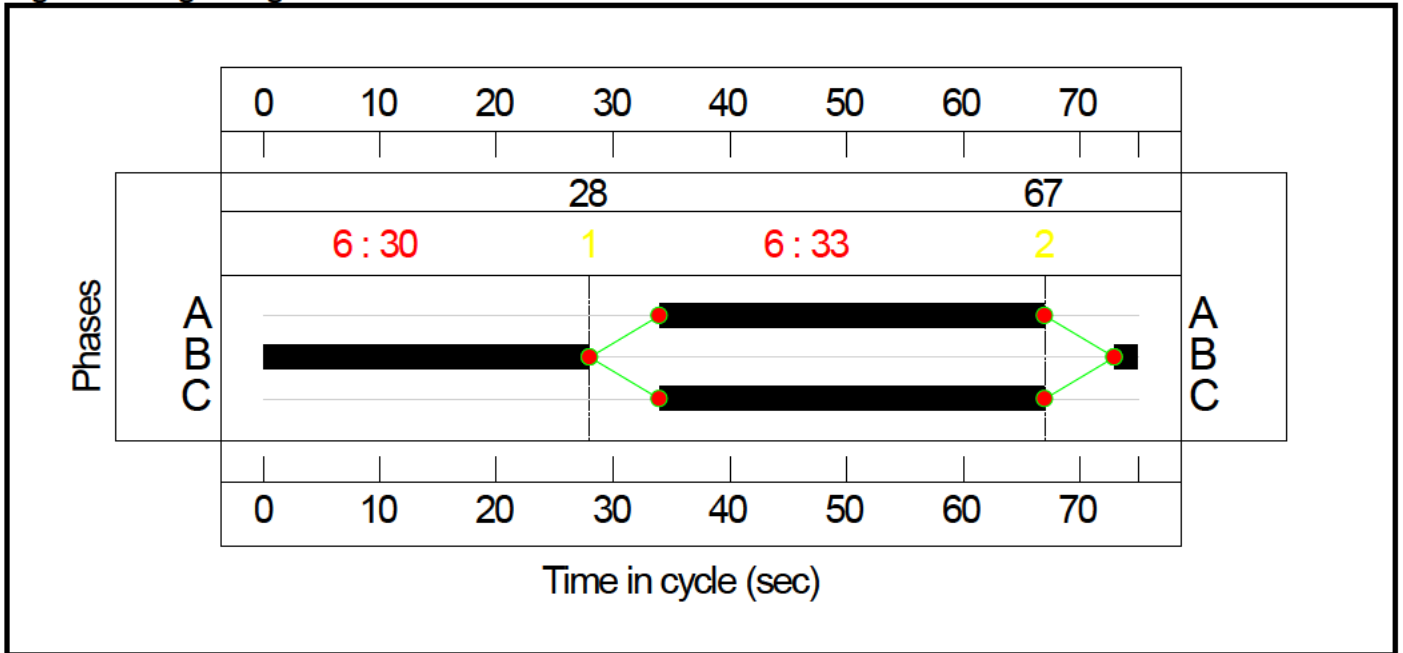

Network Layout Diagram

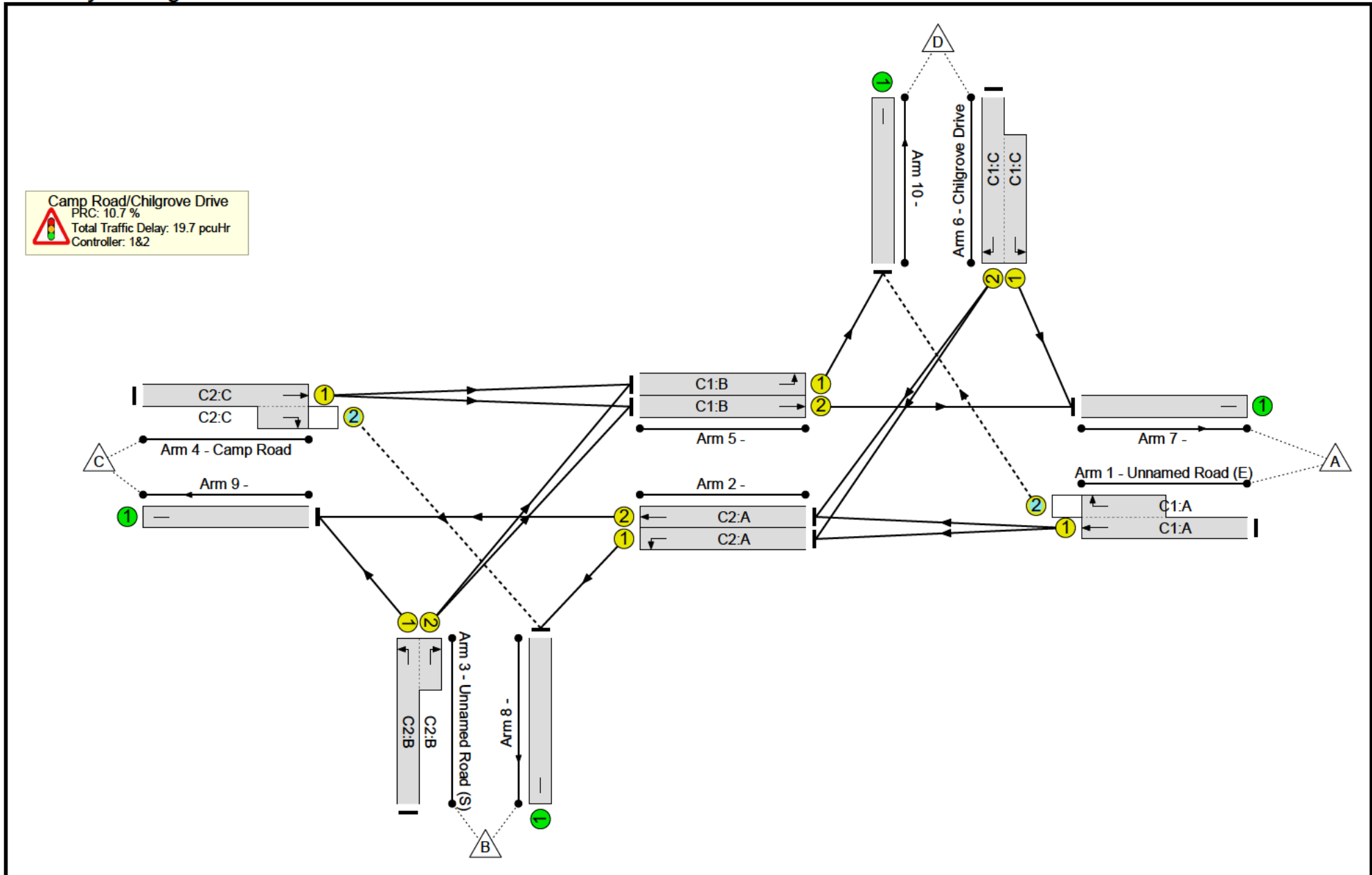

Network Results

Item	Lane Description	Lane Type	Controller Stream	Position In Filtered Route	Full Phase	Arrow Phase	Num Greens	Total Green (s)	Arrow Green (s)	Demand Flow (pcu)	Sat Flow (pcu/Hr)	Capacity (pcu)	Deg Sat (%)
Network: Camp Road/Chilgrove Drive Signalisation	-	-	N/A	-	-		-	-	-	-	-	-	81.3%
Camp Road/Chilgrove Drive	-	-	N/A	-	-		-	-	-	-	-	-	81.3%
1/1+1/2	Unnamed Road (E) Ahead Right	U+O	N/A	N/A	C1:A		1	47	-	427	1965:1786	94+433	81.0 : 81.0%
2/1	Left	U	N/A	N/A	C2:A		1	33	-	23	1709	775	3.0%
2/2	Ahead	U	N/A	N/A	C2:A		1	33	-	93	1965	891	10.4%
3/1+3/2	Unnamed Road (S) Right Left	U	N/A	N/A	C2:B		1	30	-	492	1709:1786	276+553	59.3 : 59.3%
4/1+4/2	Camp Road Ahead Right	U+O	N/A	N/A	C2:C		1	33	-	702	1965:1786	883+35	76.4 : 76.4%
5/1	Left	U	N/A	N/A	C1:B		1	48	-	378	1709	1117	33.9%
5/2	Ahead	U	N/A	N/A	C1:B		1	48	-	625	1965	1284	48.7%
6/2+6/1	Chilgrove Drive Right Left	U	N/A	N/A	C1:C		1	16	-	355	1786:1709	49+387	81.3 : 81.3%
7/1		U	N/A	N/A	-		-	-	-	940	Inf	Inf	0.0%
8/1		U	N/A	N/A	-		-	-	-	50	Inf	Inf	0.0%
9/1		U	N/A	N/A	-		-	-	-	257	Inf	Inf	0.0%
10/1		U	N/A	N/A	-		-	-	-	729	Inf	Inf	0.0%

Scenario 4: '2031 Reference Case + Development PM' (FG4: '2031 Reference Case + Development PM', Plan 1: 'Network Control Plan 1')

C1

Stage Sequence Diagram

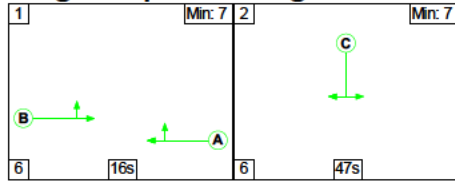

Stage Timings

Stage	1	2
Duration	16	47
Change Point	0	22

Signal Timings Diagram

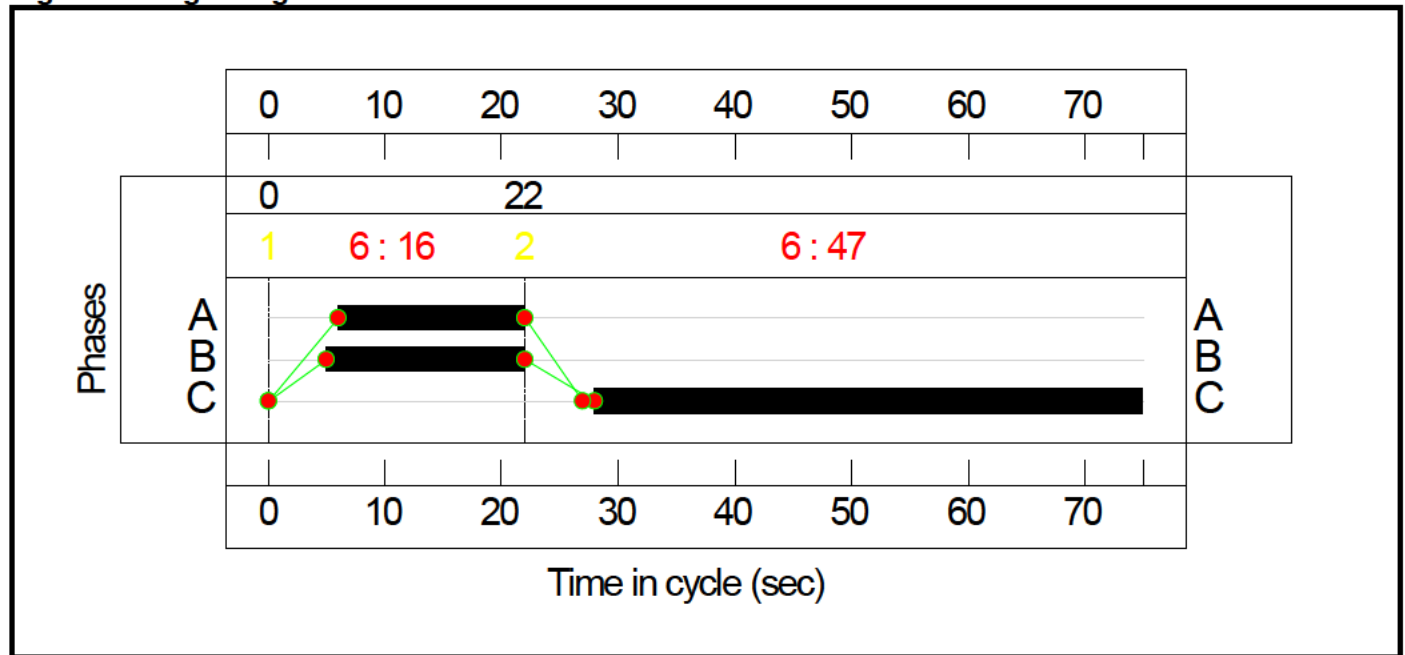

C2

Stage Sequence Diagram

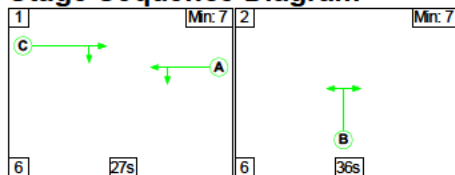

Stage Timings

Stage	1	2
Duration	27	36
Change Point	69	27

Signal Timings Diagram

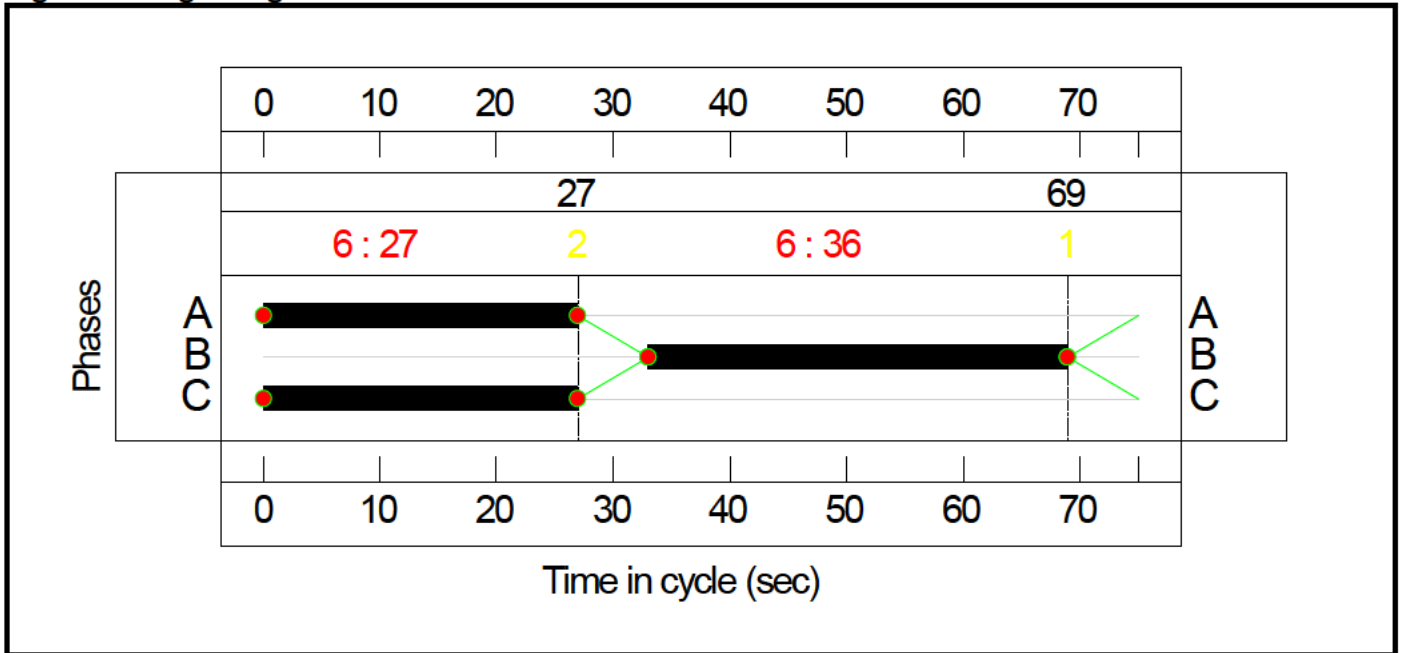

Network Layout Diagram

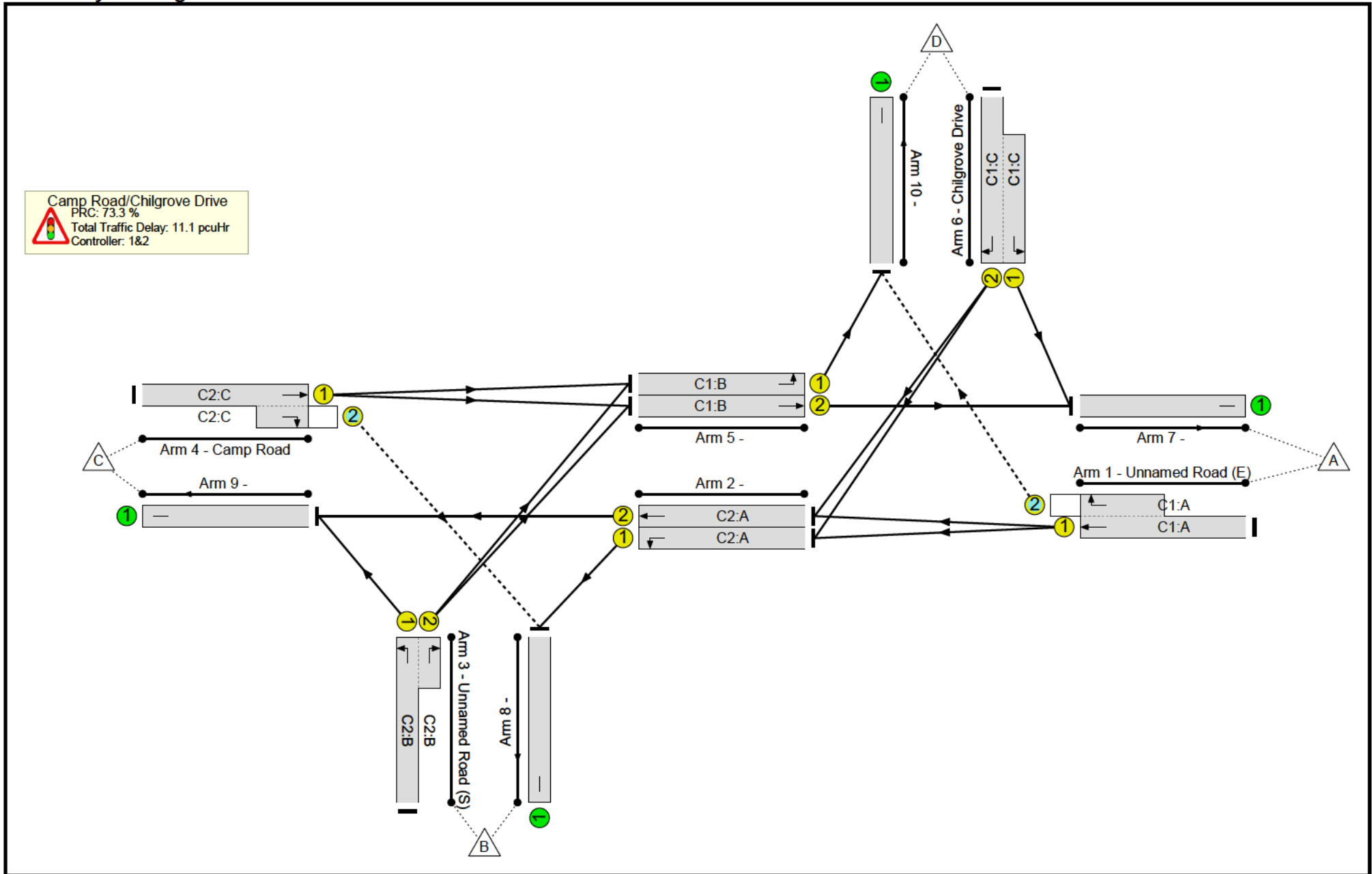

Network Results

Item	Lane Description	Lane Type	Controller Stream	Position In Filtered Route	Full Phase	Arrow Phase	Num Greens	Total Green (s)	Arrow Green (s)	Demand Flow (pcu)	Sat Flow (pcu/Hr)	Capacity (pcu)	Deg Sat (%)
Network: Camp Road/Chilgrove Drive Signalisation	-	-	N/A	-	-		-	-	-	-	-	-	51.9%
Camp Road/Chilgrove Drive	-	-	N/A	-	-		-	-	-	-	-	-	51.9%
1/1+1/2	Unnamed Road (E) Ahead Right	U+O	N/A	N/A	C1:A		1	16	-	197	1965:1786	184+198	51.6 : 51.6%
2/1	Left	U	N/A	N/A	C2:A		1	27	-	52	1709	638	8.2%
2/2	Ahead	U	N/A	N/A	C2:A		1	27	-	161	1965	734	21.9%
3/1+3/2	Unnamed Road (S) Right Left	U	N/A	N/A	C2:B		1	36	-	416	1709:1786	567+445	41.1 : 41.1%
4/1+4/2	Camp Road Ahead Right	U+O	N/A	N/A	C2:C		1	27	-	249	1965:1786	734+21	33.0 : 33.0%
5/1	Left	U	N/A	N/A	C1:B		1	17	-	188	1709	410	45.8%
5/2	Ahead	U	N/A	N/A	C1:B		1	17	-	237	1965	472	50.3%
6/2+6/1	Chilgrove Drive Right Left	U	N/A	N/A	C1:C		1	47	-	629	1786:1709	227+984	51.9 : 51.9%
7/1		U	N/A	N/A	-		-	-	-	748	Inf	Inf	0.0%
8/1		U	N/A	N/A	-		-	-	-	59	Inf	Inf	0.0%
9/1		U	N/A	N/A	-		-	-	-	394	Inf	Inf	0.0%
10/1		U	N/A	N/A	-		-	-	-	290	Inf	Inf	0.0%

Item	Arriving (pcu)	Leaving (pcu)	Turners In Gaps (pcu)	Turners When Unopposed (pcu)	Turners In Intergreen (pcu)	Uniform Delay (pcuHr)	Rand + Oversat Delay (pcuHr)	Storage Area Uniform Delay (pcuHr)	Total Delay (pcuHr)	Av. Delay Per PCU (s/pcu)	Max. Back of Uniform Queue (pcu)	Rand + Oversat Queue (pcu)	Mean Max Queue (pcu)																					
Network: Camp Road/Chilgrove Drive Signalisation	-	-	109	0	0	8.0	2.8	0.2	11.1	-	-	-	-																					
Camp Road/Chilgrove Drive	-	-	109	0	0	8.0	2.8	0.2	11.1	-	-	-	-																					
1/1+1/2	197	197	102	0	0	1.3	0.5	0.2	2.1	37.7	1.7	0.5	2.3																					
2/1	52	52	-	-	-	0.4	0.0	-	0.4	28.5	1.0	0.0	1.0																					
2/2	161	161	-	-	-	0.5	0.1	-	0.7	14.7	1.3	0.1	1.5																					
3/1+3/2	416	416	-	-	-	1.3	0.3	-	1.6	14.0	2.8	0.3	3.1																					
4/1+4/2	249	249	7	0	0	1.2	0.2	0.0	1.4	20.4	3.6	0.2	3.8																					
5/1	188	188	-	-	-	1.7	0.4	-	2.1	39.7	3.8	0.4	4.3																					
5/2	237	237	-	-	-	0.6	0.5	-	1.1	17.3	2.7	0.5	3.2																					
6/2+6/1	629	629	-	-	-	1.2	0.5	-	1.7	9.7	5.4	0.5	5.9																					
7/1	748	748	-	-	-	0.0	0.0	-	0.0	0.0	0.0	0.0	0.0																					
8/1	59	59	-	-	-	0.0	0.0	-	0.0	0.0	0.0	0.0	0.0																					
9/1	394	394	-	-	-	0.0	0.0	-	0.0	0.0	0.0	0.0	0.0																					
10/1	290	290	-	-	-	0.0	0.0	-	0.0	0.0	0.0	0.0	0.0																					
<table style="width:100%; border:none;"> <tr> <td style="width:15%;">C1</td> <td style="width:15%;">PRC for Signalled Lanes (%):</td> <td style="width:15%;">73.3</td> <td style="width:15%;">Total Delay for Signalled Lanes (pcuHr):</td> <td style="width:15%;">6.96</td> <td style="width:15%;">Cycle Time (s):</td> <td style="width:15%;">75</td> </tr> <tr> <td>C2</td> <td>PRC for Signalled Lanes (%):</td> <td>118.8</td> <td>Total Delay for Signalled Lanes (pcuHr):</td> <td>4.09</td> <td>Cycle Time (s):</td> <td>75</td> </tr> <tr> <td></td> <td>PRC Over All Lanes (%):</td> <td>73.3</td> <td>Total Delay Over All Lanes(pcuHr):</td> <td>11.06</td> <td></td> <td></td> </tr> </table>														C1	PRC for Signalled Lanes (%):	73.3	Total Delay for Signalled Lanes (pcuHr):	6.96	Cycle Time (s):	75	C2	PRC for Signalled Lanes (%):	118.8	Total Delay for Signalled Lanes (pcuHr):	4.09	Cycle Time (s):	75		PRC Over All Lanes (%):	73.3	Total Delay Over All Lanes(pcuHr):	11.06		
C1	PRC for Signalled Lanes (%):	73.3	Total Delay for Signalled Lanes (pcuHr):	6.96	Cycle Time (s):	75																												
C2	PRC for Signalled Lanes (%):	118.8	Total Delay for Signalled Lanes (pcuHr):	4.09	Cycle Time (s):	75																												
	PRC Over All Lanes (%):	73.3	Total Delay Over All Lanes(pcuHr):	11.06																														

T19562
Heyford Park



Appendix F

LinSig Output – Camp Road/Chilgrove Drive with Crossing

Full Input Data And Results

User and Project Details

Project:	Heyford Park
Title:	Camp Road/Chilgrove Drive Signalisation
Location:	
Client:	Richborough Estates
Site Ref(s):	T19562
Date Started:	24/11/2021
Additional detail:	
File name:	T19562 - Camp Road-Chilgrove Drive - with Crossing.lsg3x
Author:	Max law
Company:	Hub Transport Planning Lttd
Address:	Radclyffe House, 66/68 Hagley Road, Edgbaston, Birmingham, West Midlands, B16 8PF

Network Layout Diagram

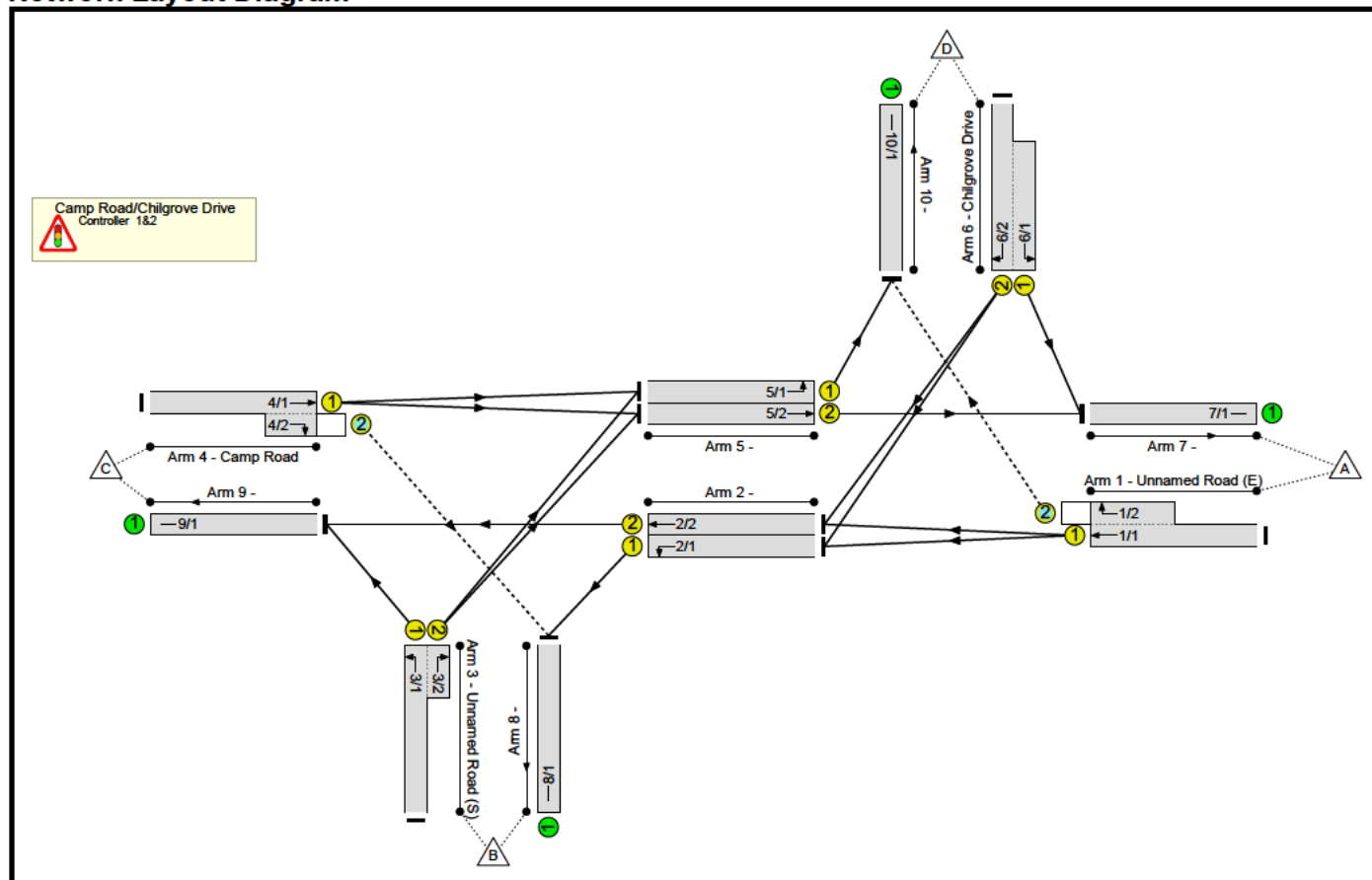

**C1
Phase Diagram**

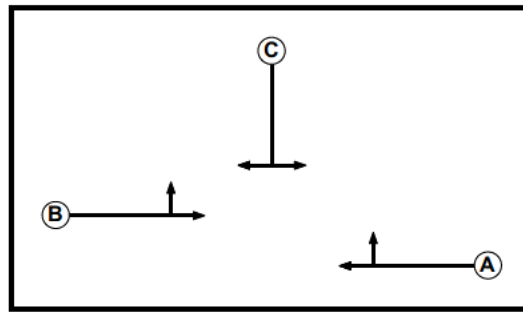

Phase Input Data

Phase Name	Phase Type	Assoc. Phase	Street Min	Cont Min
A	Traffic		7	7
B	Traffic		7	7
C	Traffic		7	7

Phase Intergreens Matrix

		Starting Phase		
		A	B	C
Terminating Phase	A	-	-	5
	B	-	-	6
	C	6	5	-

Phases in Stage

Stage No.	Phases in Stage
1	A B
2	C

Stage Diagram

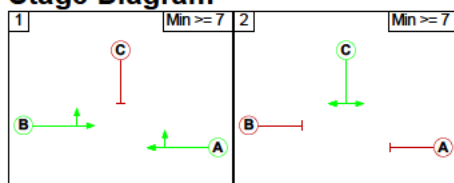

Phase Delays

Term. Stage	Start Stage	Phase	Type	Value	Cont value
There are no Phase Delays defined					

Prohibited Stage Change

		To Stage	
		1	2
From Stage	1	-	6
	2	6	-

**C2
Phase Diagram**

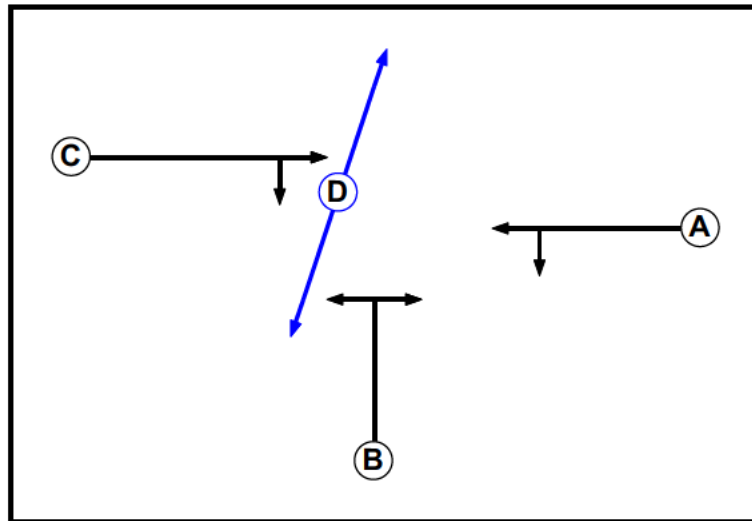

Phase Input Data

Phase Name	Phase Type	Assoc. Phase	Street Min	Cont Min
A	Traffic		7	7
B	Traffic		7	7
C	Traffic		7	7
D	Pedestrian		16	16

Phase Intergreens Matrix

		Starting Phase				
		A	B	C	D	
Terminating Phase	A	6	-	9		
	B	6	6	6		
	C	-	6	5		
	D	5	5	5		

Phases in Stage

Stage No.	Phases in Stage
1	A C
2	B
3	D

Stage Diagram

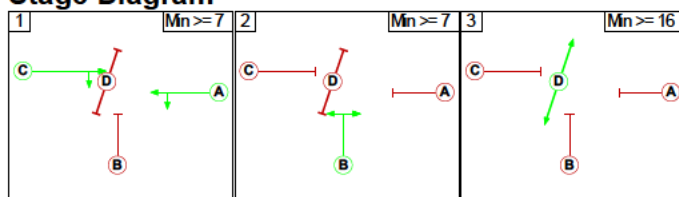

Phase Delays

Term. Stage	Start Stage	Phase	Type	Value	Cont value
There are no Phase Delays defined					

Prohibited Stage Change

		To Stage		
		1	2	3
From Stage	1		6	9
	2	6		6
	3	5	5	

Give-Way Lane Input Data

Junction: Camp Road/Chilgrove Drive											
Lane	Movement	Max Flow when Giving Way (PCU/Hr)	Min Flow when Giving Way (PCU/Hr)	Opposing Lane	Opp. Lane Coeff.	Opp. Mvmnts.	Right Turn Storage (PCU)	Non-Blocking Storage (PCU)	RTF	Right Turn Move up (s)	Max Turns in Intergreen (PCU)
1/2 (Unnamed Road (E))	10/1 (Right)	1439	0	5/2	1.09	To 7/1 (Ahead)	2.00	-	0.50	2	2.00
				5/1	1.09	To 10/1 (Left)					
4/2 (Camp Road)	8/1 (Right)	1439	0	2/2	1.09	To 9/1 (Ahead)	2.00	-	0.50	2	2.00
				2/1	1.09	To 8/1 (Left)					

Lane Input Data

Junction: Camp Road/Chilgrove Drive												
Lane	Lane Type	Phases	Start Disp.	End Disp.	Physical Length (PCU)	Sat Flow Type	Def User Saturation Flow (PCU/Hr)	Lane Width (m)	Gradient	Nearside Lane	Turns	Turning Radius (m)
1/1 (Unnamed Road (E))	U	A	2	3	60.0	Geom	-	3.50	0.00	Y	Arm 2 Ahead	Inf
1/2 (Unnamed Road (E))	O	A	2	3	5.7	Geom	-	3.50	0.00	Y	Arm 10 Right	15.00
2/1	U	A	2	3	8.7	Geom	-	3.50	0.00	Y	Arm 8 Left	10.00
2/2	U	A	2	3	8.7	Geom	-	3.50	0.00	Y	Arm 9 Ahead	Inf
3/1 (Unnamed Road (S))	U	B	2	3	60.0	Geom	-	3.50	0.00	Y	Arm 9 Left	10.00
3/2 (Unnamed Road (S))	U	B	2	3	3.5	Geom	-	3.50	0.00	Y	Arm 5 Right	15.00
4/1 (Camp Road)	U	C	2	3	60.0	Geom	-	3.50	0.00	Y	Arm 5 Ahead	Inf
4/2 (Camp Road)	O	C	2	3	3.5	Geom	-	3.50	0.00	Y	Arm 8 Right	15.00
5/1	U	B	2	3	8.7	Geom	-	3.50	0.00	Y	Arm 10 Left	10.00
5/2	U	B	2	3	8.7	Geom	-	3.50	0.00	Y	Arm 7 Ahead	Inf
6/1 (Chilgrove Drive)	U	C	2	3	8.7	Geom	-	3.50	0.00	Y	Arm 7 Left	10.00
6/2 (Chilgrove Drive)	U	C	2	3	60.0	Geom	-	3.50	0.00	Y	Arm 2 Right	15.00
7/1	U		2	3	60.0	Inf	-	-	-	-	-	-
8/1	U		2	3	60.0	Inf	-	-	-	-	-	-
9/1	U		2	3	60.0	Inf	-	-	-	-	-	-
10/1	U		2	3	60.0	Inf	-	-	-	-	-	-

Traffic Flow Groups

Flow Group	Start Time	End Time	Duration	Formula
1: '2031 Reference Case AM'	08:00	09:00	01:00	
2: '2031 Reference Case PM'	17:00	18:00	01:00	
3: '2031 Reference Case + Development AM'	08:00	09:00	01:00	
4: '2031 Reference Case + Development PM'	17:00	18:00	01:00	

Scenario 1: '2031 Reference Case AM' (FG1: '2031 Reference Case AM', Plan 1: 'Network Control Plan 1')

Traffic Flows, Desired

Desired Flow :

	Destination					Tot.
	A	B	C	D		
Origin	A	0	0	69	349	418
	B	26	0	149	298	473
	C	545	6	0	68	619
	D	316	23	16	0	355
	Tot.	887	29	234	715	1865

Traffic Lane Flows

Lane	Scenario 1: 2031 Reference Case AM
Junction: Camp Road/Chilgrove Drive	
1/1 (with short)	418(In) 69(Out)
1/2 (short)	349
2/1	23
2/2	85
3/1 (with short)	473(In) 149(Out)
3/2 (short)	324
4/1 (with short)	619(In) 613(Out)
4/2 (short)	6
5/1	366
5/2	571
6/1 (short)	316
6/2 (with short)	355(In) 39(Out)
7/1	887
8/1	29
9/1	234
10/1	715

Lane Saturation Flows

Junction: Camp Road/Chilgrove Drive								
Lane	Lane Width (m)	Gradient	Nearside Lane	Allowed Turns	Turning Radius (m)	Turning Prop.	Sat Flow (PCU/Hr)	Flared Sat Flow (PCU/Hr)
1/1 (Unnamed Road (E))	3.50	0.00	Y	Arm 2 Ahead	Inf	100.0 %	1965	1965
1/2 (Unnamed Road (E))	3.50	0.00	Y	Arm 10 Right	15.00	100.0 %	1786	1786
2/1	3.50	0.00	Y	Arm 8 Left	10.00	100.0 %	1709	1709
2/2	3.50	0.00	Y	Arm 9 Ahead	Inf	100.0 %	1965	1965
3/1 (Unnamed Road (S))	3.50	0.00	Y	Arm 9 Left	10.00	100.0 %	1709	1709
3/2 (Unnamed Road (S))	3.50	0.00	Y	Arm 5 Right	15.00	100.0 %	1786	1786
4/1 (Camp Road)	3.50	0.00	Y	Arm 5 Ahead	Inf	100.0 %	1965	1965
4/2 (Camp Road)	3.50	0.00	Y	Arm 8 Right	15.00	100.0 %	1786	1786
5/1	3.50	0.00	Y	Arm 10 Left	10.00	100.0 %	1709	1709
5/2	3.50	0.00	Y	Arm 7 Ahead	Inf	100.0 %	1965	1965
6/1 (Chilgrove Drive)	3.50	0.00	Y	Arm 7 Left	10.00	100.0 %	1709	1709
6/2 (Chilgrove Drive)	3.50	0.00	Y	Arm 2 Right	15.00	100.0 %	1786	1786
7/1	Infinite Saturation Flow						Inf	Inf
8/1	Infinite Saturation Flow						Inf	Inf
9/1	Infinite Saturation Flow						Inf	Inf
10/1	Infinite Saturation Flow						Inf	Inf

Scenario 2: '2031 Reference Case PM' (FG2: '2031 Reference Case PM', Plan 1: 'Network Control Plan 1')
Traffic Flows, Desired

Desired Flow :

	Destination					
	A	B	C	D	Tot.	
Origin	A	0	1	76	100	177
	B	13	0	193	171	377
	C	203	3	0	17	223
	D	511	51	62	0	624
	Tot.	727	55	331	288	1401

Traffic Lane Flows

Lane	Scenario 2: 2031 Reference Case PM
Junction: Camp Road/Chilgrove Drive	
1/1 (with short)	177(In) 77(Out)
1/2 (short)	100
2/1	52
2/2	138
3/1 (with short)	377(In) 193(Out)
3/2 (short)	184
4/1 (with short)	223(In) 220(Out)
4/2 (short)	3
5/1	188
5/2	216
6/1 (short)	511
6/2 (with short)	624(In) 113(Out)
7/1	727
8/1	55
9/1	331
10/1	288

Lane Saturation Flows

Junction: Camp Road/Chilgrove Drive								
Lane	Lane Width (m)	Gradient	Nearside Lane	Allowed Turns	Turning Radius (m)	Turning Prop.	Sat Flow (PCU/Hr)	Flared Sat Flow (PCU/Hr)
1/1 (Unnamed Road (E))	3.50	0.00	Y	Arm 2 Ahead	Inf	100.0 %	1965	1965
1/2 (Unnamed Road (E))	3.50	0.00	Y	Arm 10 Right	15.00	100.0 %	1786	1786
2/1	3.50	0.00	Y	Arm 8 Left	10.00	100.0 %	1709	1709
2/2	3.50	0.00	Y	Arm 9 Ahead	Inf	100.0 %	1965	1965
3/1 (Unnamed Road (S))	3.50	0.00	Y	Arm 9 Left	10.00	100.0 %	1709	1709
3/2 (Unnamed Road (S))	3.50	0.00	Y	Arm 5 Right	15.00	100.0 %	1786	1786
4/1 (Camp Road)	3.50	0.00	Y	Arm 5 Ahead	Inf	100.0 %	1965	1965
4/2 (Camp Road)	3.50	0.00	Y	Arm 8 Right	15.00	100.0 %	1786	1786
5/1	3.50	0.00	Y	Arm 10 Left	10.00	100.0 %	1709	1709
5/2	3.50	0.00	Y	Arm 7 Ahead	Inf	100.0 %	1965	1965
6/1 (Chilgrove Drive)	3.50	0.00	Y	Arm 7 Left	10.00	100.0 %	1709	1709
6/2 (Chilgrove Drive)	3.50	0.00	Y	Arm 2 Right	15.00	100.0 %	1786	1786
7/1	Infinite Saturation Flow						Inf	Inf
8/1	Infinite Saturation Flow						Inf	Inf
9/1	Infinite Saturation Flow						Inf	Inf
10/1	Infinite Saturation Flow						Inf	Inf

Scenario 3: '2031 Reference Case + Development AM' (FG3: '2031 Reference Case + Development AM', Plan 1: 'Network Control Plan 1')

Traffic Flows, Desired

Desired Flow :

	Destination					Tot.
	A	B	C	D		
Origin	A	0	0	76	351	427
	B	26	0	164	302	492
	C	599	27	0	76	702
	D	315	23	17	0	355
	Tot.	940	50	257	729	1976

Traffic Lane Flows

Lane	Scenario 3: 2031 Reference Case + Development AM
Junction: Camp Road/Chilgrove Drive	
1/1 (with short)	427(In) 76(Out)
1/2 (short)	351
2/1	23
2/2	93
3/1 (with short)	492(In) 164(Out)
3/2 (short)	328
4/1 (with short)	702(In) 675(Out)
4/2 (short)	27
5/1	378
5/2	625
6/1 (short)	315
6/2 (with short)	355(In) 40(Out)
7/1	940
8/1	50
9/1	257
10/1	729

Lane Saturation Flows

Junction: Camp Road/Chilgrove Drive								
Lane	Lane Width (m)	Gradient	Nearside Lane	Allowed Turns	Turning Radius (m)	Turning Prop.	Sat Flow (PCU/Hr)	Flared Sat Flow (PCU/Hr)
1/1 (Unnamed Road (E))	3.50	0.00	Y	Arm 2 Ahead	Inf	100.0 %	1965	1965
1/2 (Unnamed Road (E))	3.50	0.00	Y	Arm 10 Right	15.00	100.0 %	1786	1786
2/1	3.50	0.00	Y	Arm 8 Left	10.00	100.0 %	1709	1709
2/2	3.50	0.00	Y	Arm 9 Ahead	Inf	100.0 %	1965	1965
3/1 (Unnamed Road (S))	3.50	0.00	Y	Arm 9 Left	10.00	100.0 %	1709	1709
3/2 (Unnamed Road (S))	3.50	0.00	Y	Arm 5 Right	15.00	100.0 %	1786	1786
4/1 (Camp Road)	3.50	0.00	Y	Arm 5 Ahead	Inf	100.0 %	1965	1965
4/2 (Camp Road)	3.50	0.00	Y	Arm 8 Right	15.00	100.0 %	1786	1786
5/1	3.50	0.00	Y	Arm 10 Left	10.00	100.0 %	1709	1709
5/2	3.50	0.00	Y	Arm 7 Ahead	Inf	100.0 %	1965	1965
6/1 (Chilgrove Drive)	3.50	0.00	Y	Arm 7 Left	10.00	100.0 %	1709	1709
6/2 (Chilgrove Drive)	3.50	0.00	Y	Arm 2 Right	15.00	100.0 %	1786	1786
7/1	Infinite Saturation Flow						Inf	Inf
8/1	Infinite Saturation Flow						Inf	Inf
9/1	Infinite Saturation Flow						Inf	Inf
10/1	Infinite Saturation Flow						Inf	Inf

Scenario 4: '2031 Reference Case + Development PM' (FG4: '2031 Reference Case + Development PM', Plan 1: 'Network Control Plan 1')

Traffic Flows, Desired

Desired Flow :

	Destination					Tot.
	A	B	C	D		
Origin	A	0	1	94	102	197
	B	13	0	233	170	416
	C	224	7	0	18	249
	D	511	51	67	0	629
	Tot.	748	59	394	290	1491

Traffic Lane Flows

Lane	Scenario 4: 2031 Reference Case + Development PM
Junction: Camp Road/Chilgrove Drive	
1/1 (with short)	197(In) 95(Out)
1/2 (short)	102
2/1	52
2/2	161
3/1 (with short)	416(In) 233(Out)
3/2 (short)	183
4/1 (with short)	249(In) 242(Out)
4/2 (short)	7
5/1	188
5/2	237
6/1 (short)	511
6/2 (with short)	629(In) 118(Out)
7/1	748
8/1	59
9/1	394
10/1	290

Lane Saturation Flows

Junction: Camp Road/Chilgrove Drive								
Lane	Lane Width (m)	Gradient	Nearside Lane	Allowed Turns	Turning Radius (m)	Turning Prop.	Sat Flow (PCU/Hr)	Flared Sat Flow (PCU/Hr)
1/1 (Unnamed Road (E))	3.50	0.00	Y	Arm 2 Ahead	Inf	100.0 %	1965	1965
1/2 (Unnamed Road (E))	3.50	0.00	Y	Arm 10 Right	15.00	100.0 %	1786	1786
2/1	3.50	0.00	Y	Arm 8 Left	10.00	100.0 %	1709	1709
2/2	3.50	0.00	Y	Arm 9 Ahead	Inf	100.0 %	1965	1965
3/1 (Unnamed Road (S))	3.50	0.00	Y	Arm 9 Left	10.00	100.0 %	1709	1709
3/2 (Unnamed Road (S))	3.50	0.00	Y	Arm 5 Right	15.00	100.0 %	1786	1786
4/1 (Camp Road)	3.50	0.00	Y	Arm 5 Ahead	Inf	100.0 %	1965	1965
4/2 (Camp Road)	3.50	0.00	Y	Arm 8 Right	15.00	100.0 %	1786	1786
5/1	3.50	0.00	Y	Arm 10 Left	10.00	100.0 %	1709	1709
5/2	3.50	0.00	Y	Arm 7 Ahead	Inf	100.0 %	1965	1965
6/1 (Chilgrove Drive)	3.50	0.00	Y	Arm 7 Left	10.00	100.0 %	1709	1709
6/2 (Chilgrove Drive)	3.50	0.00	Y	Arm 2 Right	15.00	100.0 %	1786	1786
7/1	Infinite Saturation Flow						Inf	Inf
8/1	Infinite Saturation Flow						Inf	Inf
9/1	Infinite Saturation Flow						Inf	Inf
10/1	Infinite Saturation Flow						Inf	Inf

Scenario 1: '2031 Reference Case AM' (FG1: '2031 Reference Case AM', Plan 1: 'Network Control Plan 1')
C1

Stage Sequence Diagram

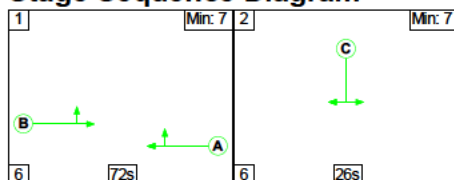

Stage Timings

Stage	1	2
Duration	72	26
Change Point	0	78

Signal Timings Diagram

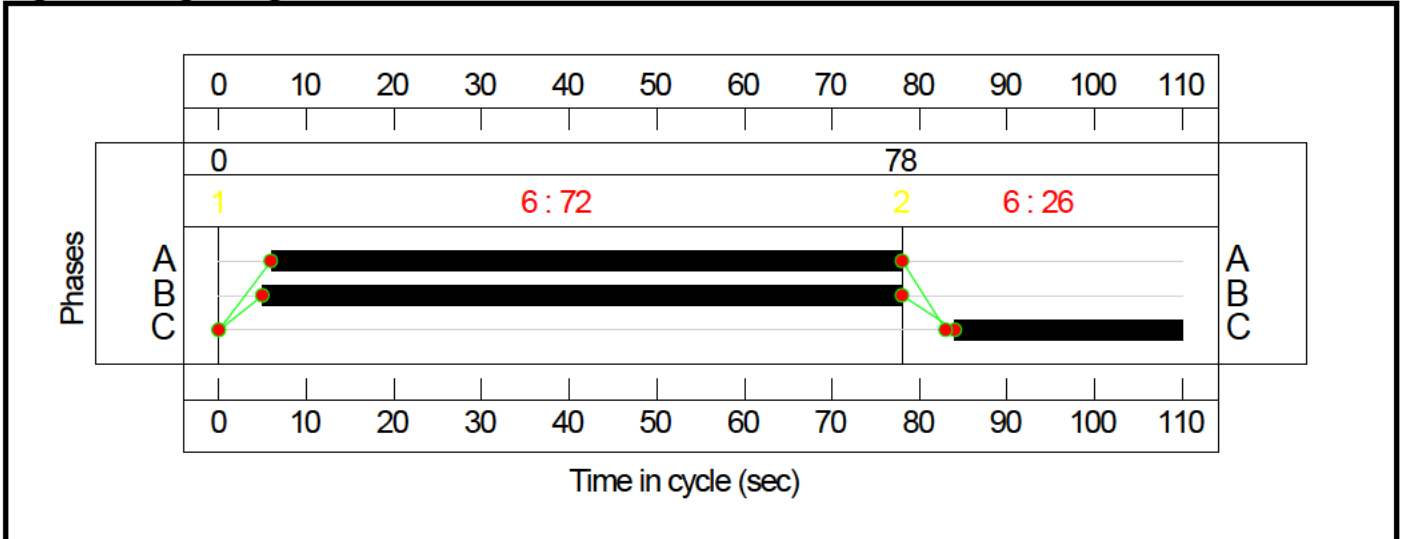

C2 Stage Sequence Diagram

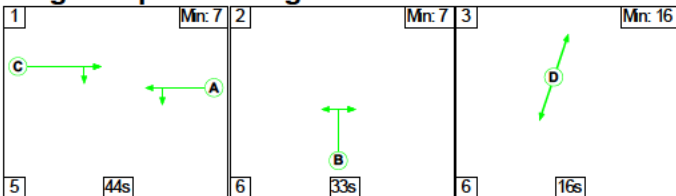

Stage Timings

Stage	1	2	3
Duration	44	33	16
Change Point	48	97	26

Signal Timings Diagram

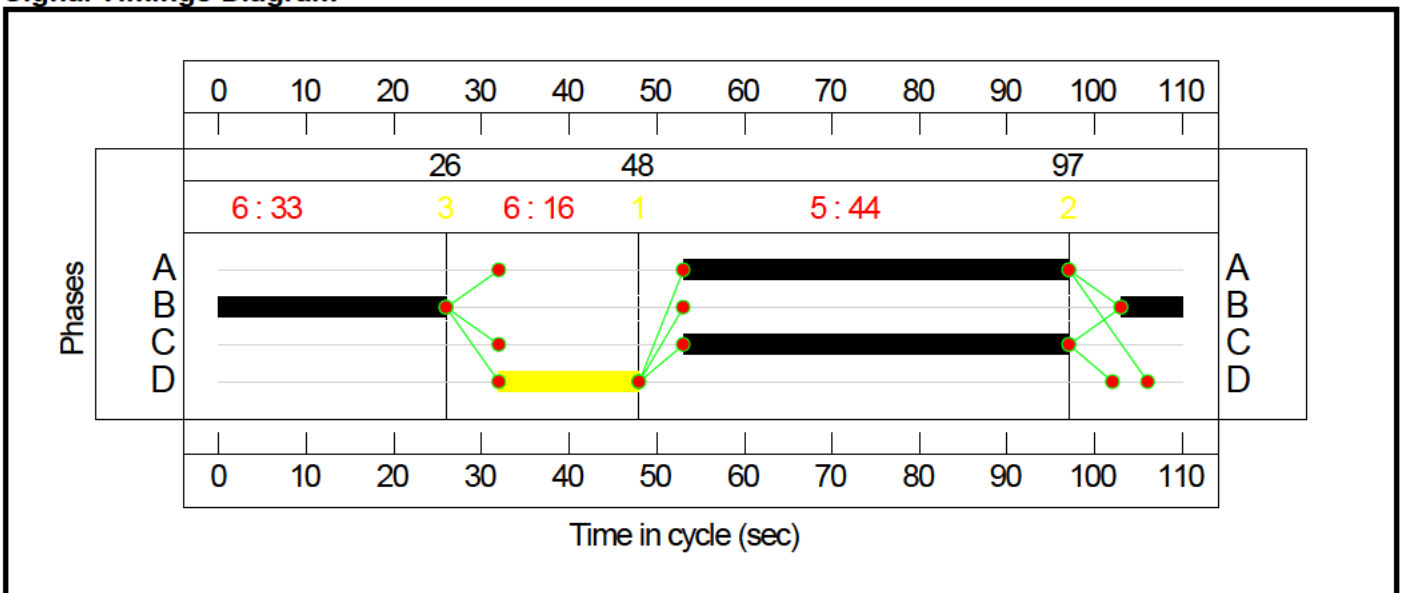

Network Layout Diagram

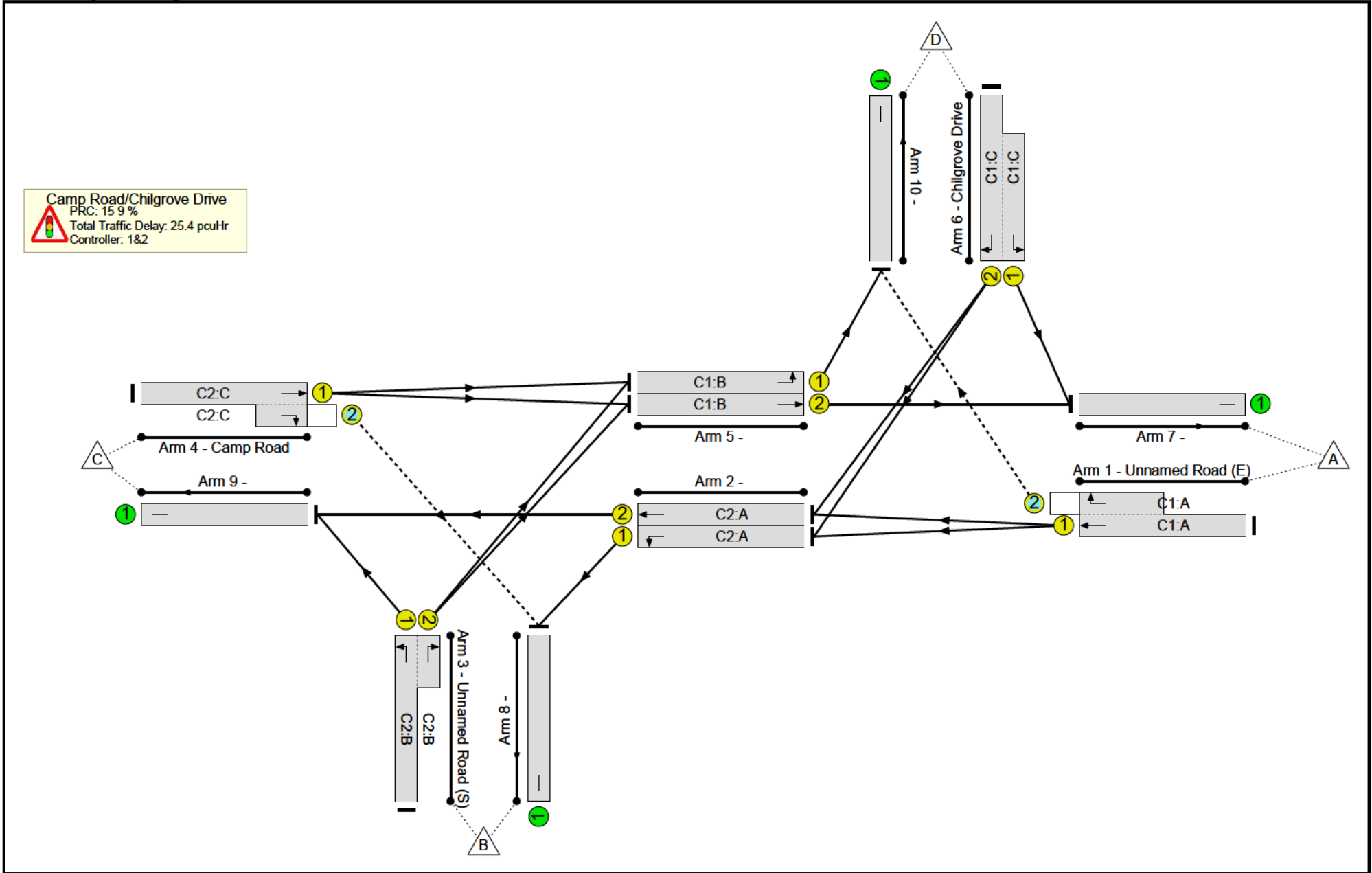

Network Results

Item	Lane Description	Lane Type	Controller Stream	Position In Filtered Route	Full Phase	Arrow Phase	Num Greens	Total Green (s)	Arrow Green (s)	Demand Flow (pcu)	Sat Flow (pcu/Hr)	Capacity (pcu)	Deg Sat (%)
Network: Camp Road/Chilgrove Drive Signalisation	-	-	N/A	-	-		-	-	-	-	-	-	77.7%
Camp Road/Chilgrove Drive	-	-	N/A	-	-		-	-	-	-	-	-	77.7%
1/1+1/2	Unnamed Road (E) Ahead Right	U+O	N/A	N/A	C1:A		1	72	-	418	1965:1786	95+479	72.8 : 72.8%
2/1	Left	U	N/A	N/A	C2:A		1	44	-	23	1709	699	3.3%
2/2	Ahead	U	N/A	N/A	C2:A		1	44	-	85	1965	804	10.6%
3/1+3/2	Unnamed Road (S) Right Left	U	N/A	N/A	C2:B		1	33	-	473	1709:1786	192+417	77.7 : 77.7%
4/1+4/2	Camp Road Ahead Right	U+O	N/A	N/A	C2:C		1	44	-	619	1965:1786	804+8	76.3 : 76.3%
5/1	Left	U	N/A	N/A	C1:B		1	73	-	366	1709	1150	31.8%
5/2	Ahead	U	N/A	N/A	C1:B		1	73	-	571	1965	1322	43.2%
6/2+6/1	Chilgrove Drive Right Left	U	N/A	N/A	C1:C		1	26	-	355	1786:1709	51+414	76.3 : 76.3%
7/1		U	N/A	N/A	-		-	-	-	887	Inf	Inf	0.0%
8/1		U	N/A	N/A	-		-	-	-	29	Inf	Inf	0.0%
9/1		U	N/A	N/A	-		-	-	-	234	Inf	Inf	0.0%
10/1		U	N/A	N/A	-		-	-	-	715	Inf	Inf	0.0%

Item	Arriving (pcu)	Leaving (pcu)	Turners In Gaps (pcu)	Turners When Unopposed (pcu)	Turners In Intergreen (pcu)	Uniform Delay (pcuHr)	Rand + Oversat Delay (pcuHr)	Storage Area Uniform Delay (pcuHr)	Total Delay (pcuHr)	Av. Delay Per PCU (s/pcu)	Max. Back of Uniform Queue (pcu)	Rand + Oversat Queue (pcu)	Mean Max Queue (pcu)																								
Network: Camp Road/Chilgrove Drive Signalisation	-	-	293	0	62	17.8	6.8	0.7	25.4	-	-	-	-																								
Camp Road/Chilgrove Drive	-	-	293	0	62	17.8	6.8	0.7	25.4	-	-	-	-																								
1/1+1/2	418	418	287	0	62	1.5	1.3	0.7	3.6	30.7	7.0	1.3	8.3																								
2/1	23	23	-	-	-	0.1	0.0	-	0.1	13.6	0.1	0.0	0.2																								
2/2	85	85	-	-	-	0.5	0.1	-	0.5	22.2	1.6	0.1	1.7																								
3/1+3/2	473	473	-	-	-	4.3	1.7	-	6.0	45.7	11.3	1.7	13.0																								
4/1+4/2	619	619	6	0	0	4.8	1.6	0.0	6.4	37.1	16.0	1.6	17.6																								
5/1	366	366	-	-	-	0.6	0.2	-	0.9	8.7	9.1	0.2	9.4																								
5/2	571	571	-	-	-	2.3	0.4	-	2.7	16.7	7.9	0.4	8.3																								
6/2+6/1	355	355	-	-	-	3.7	1.6	-	5.3	53.6	8.9	1.6	10.5																								
7/1	887	887	-	-	-	0.0	0.0	-	0.0	0.0	0.0	0.0	0.0																								
8/1	29	29	-	-	-	0.0	0.0	-	0.0	0.0	0.0	0.0	0.0																								
9/1	234	234	-	-	-	0.0	0.0	-	0.0	0.0	0.0	0.0	0.0																								
10/1	715	715	-	-	-	0.0	0.0	-	0.0	0.0	0.0	0.0	0.0																								
<table style="width:100%; border:none;"> <tr> <td style="width:15%;"></td> <td style="width:15%;">C1</td> <td style="width:15%;">PRC for Signalled Lanes (%):</td> <td style="width:15%;">18.0</td> <td style="width:15%;">Total Delay for Signalled Lanes (pcuHr):</td> <td style="width:15%;">12.38</td> <td style="width:15%;">Cycle Time (s):</td> <td style="width:15%;">110</td> </tr> <tr> <td></td> <td>C2</td> <td>PRC for Signalled Lanes (%):</td> <td>15.9</td> <td>Total Delay for Signalled Lanes (pcuHr):</td> <td>13.00</td> <td>Cycle Time (s):</td> <td>110</td> </tr> <tr> <td></td> <td></td> <td>PRC Over All Lanes (%):</td> <td>15.9</td> <td>Total Delay Over All Lanes(pcuHr):</td> <td>25.38</td> <td></td> <td></td> </tr> </table>															C1	PRC for Signalled Lanes (%):	18.0	Total Delay for Signalled Lanes (pcuHr):	12.38	Cycle Time (s):	110		C2	PRC for Signalled Lanes (%):	15.9	Total Delay for Signalled Lanes (pcuHr):	13.00	Cycle Time (s):	110			PRC Over All Lanes (%):	15.9	Total Delay Over All Lanes(pcuHr):	25.38		
	C1	PRC for Signalled Lanes (%):	18.0	Total Delay for Signalled Lanes (pcuHr):	12.38	Cycle Time (s):	110																														
	C2	PRC for Signalled Lanes (%):	15.9	Total Delay for Signalled Lanes (pcuHr):	13.00	Cycle Time (s):	110																														
		PRC Over All Lanes (%):	15.9	Total Delay Over All Lanes(pcuHr):	25.38																																

Scenario 2: '2031 Reference Case PM' (FG2: '2031 Reference Case PM', Plan 1: 'Network Control Plan 1')

C1

Stage Sequence Diagram

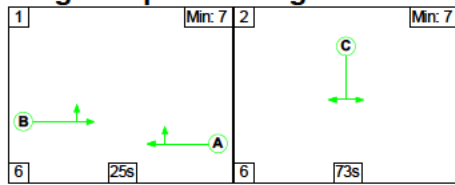

Stage Timings

Stage	1	2
Duration	25	73
Change Point	0	31

Signal Timings Diagram

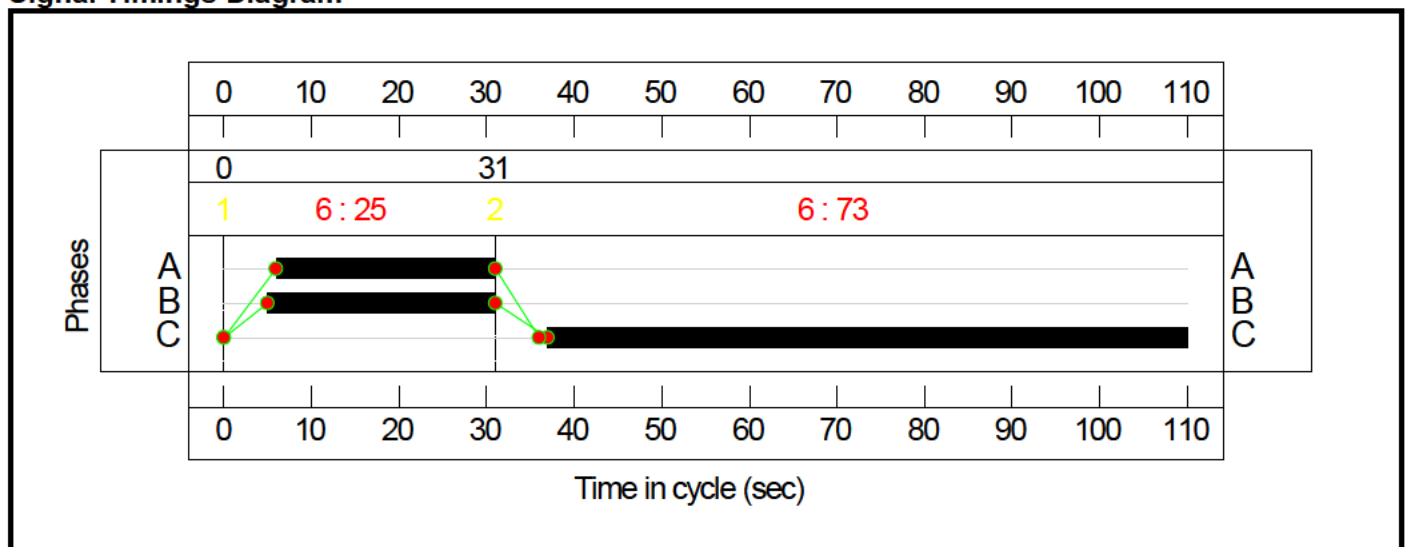

C2

Stage Sequence Diagram

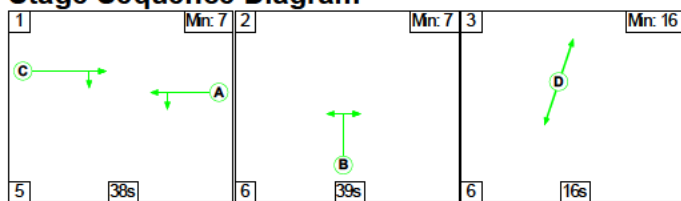

Stage Timings

Stage	1	2	3
Duration	38	39	16
Change Point	63	106	41

Signal Timings Diagram

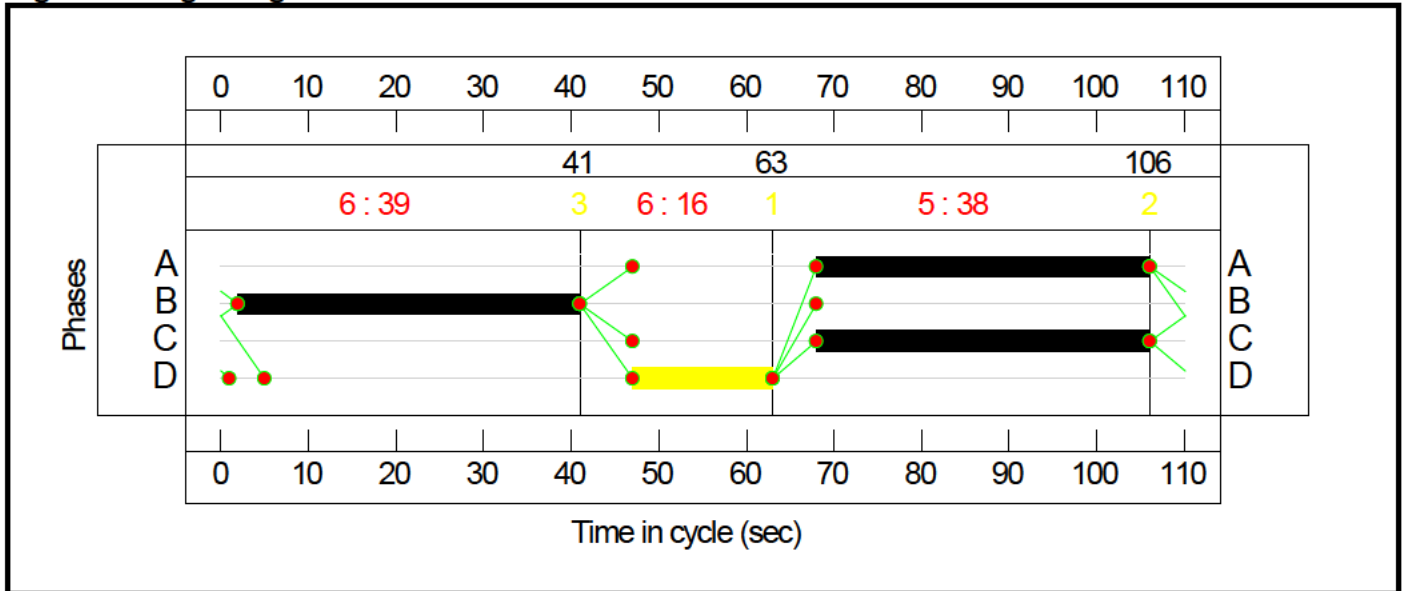

Network Layout Diagram

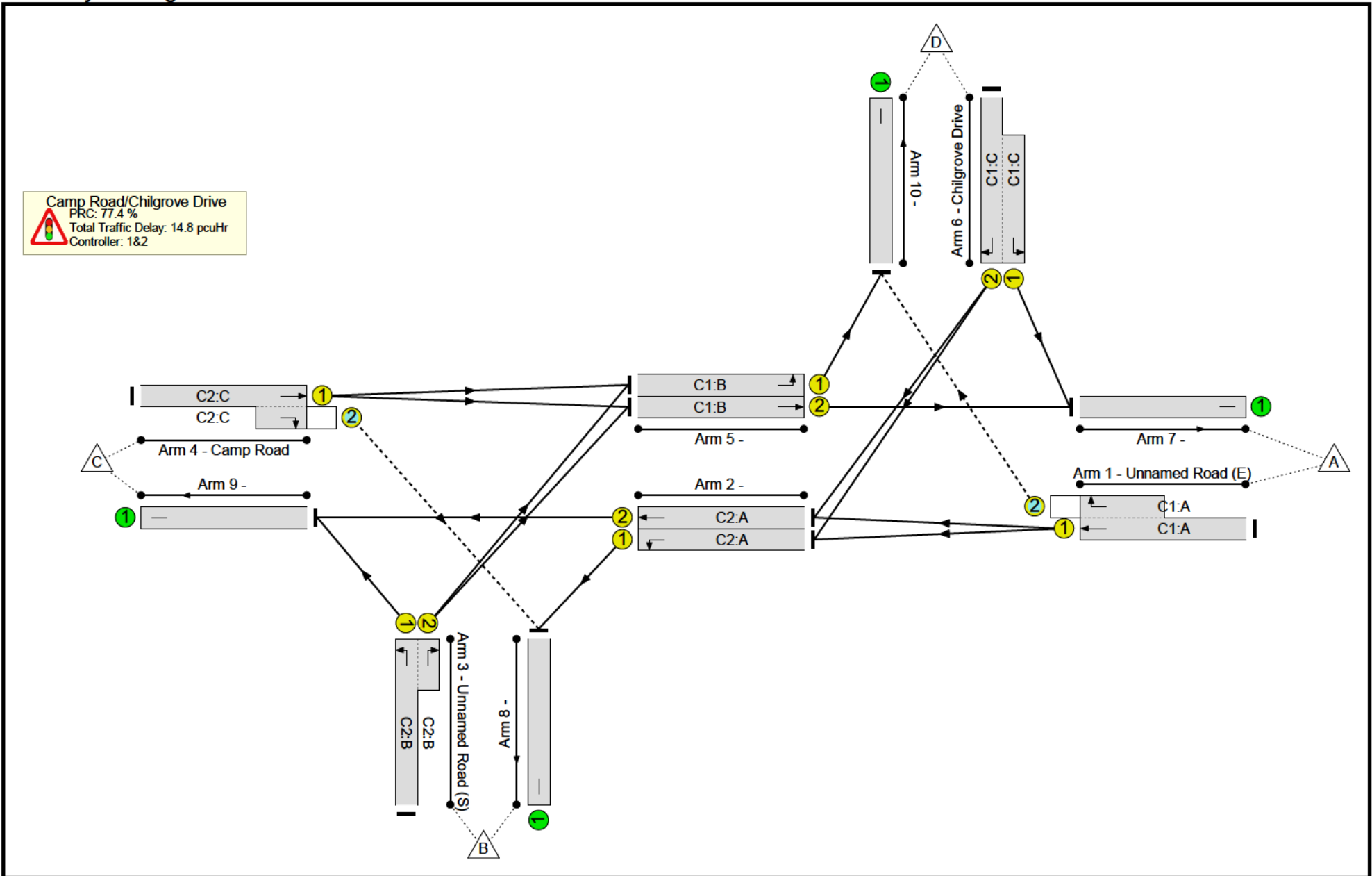

Network Results

Item	Lane Description	Lane Type	Controller Stream	Position In Filtered Route	Full Phase	Arrow Phase	Num Greens	Total Green (s)	Arrow Green (s)	Demand Flow (pcu)	Sat Flow (pcu/Hr)	Capacity (pcu)	Deg Sat (%)
Network: Camp Road/Chilgrove Drive Signalisation	-	-	N/A	-	-		-	-	-	-	-	-	50.7%
Camp Road/Chilgrove Drive	-	-	N/A	-	-		-	-	-	-	-	-	50.7%
1/1+1/2	Unnamed Road (E) Ahead Right	U+O	N/A	N/A	C1:A		1	25	-	177	1965:1786	153+199	50.3 : 50.3%
2/1	Left	U	N/A	N/A	C2:A		1	38	-	52	1709	606	8.6%
2/2	Ahead	U	N/A	N/A	C2:A		1	38	-	138	1965	697	19.8%
3/1+3/2	Unnamed Road (S) Right Left	U	N/A	N/A	C2:B		1	39	-	377	1709:1786	388+370	49.7 : 49.7%
4/1+4/2	Camp Road Ahead Right	U+O	N/A	N/A	C2:C		1	38	-	223	1965:1786	697+10	31.6 : 31.6%
5/1	Left	U	N/A	N/A	C1:B		1	26	-	188	1709	419	44.8%
5/2	Ahead	U	N/A	N/A	C1:B		1	26	-	216	1965	482	44.8%
6/2+6/1	Chilgrove Drive Right Left	U	N/A	N/A	C1:C		1	73	-	624	1786:1709	223+1007	50.7 : 50.7%
7/1		U	N/A	N/A	-		-	-	-	727	Inf	Inf	0.0%
8/1		U	N/A	N/A	-		-	-	-	55	Inf	Inf	0.0%
9/1		U	N/A	N/A	-		-	-	-	331	Inf	Inf	0.0%
10/1		U	N/A	N/A	-		-	-	-	288	Inf	Inf	0.0%

Item	Arriving (pcu)	Leaving (pcu)	Turners In Gaps (pcu)	Turners When Unopposed (pcu)	Turners In Intergreen (pcu)	Uniform Delay (pcuHr)	Rand + Oversat Delay (pcuHr)	Storage Area Uniform Delay (pcuHr)	Total Delay (pcuHr)	Av. Delay Per PCU (s/pcu)	Max. Back of Uniform Queue (pcu)	Rand + Oversat Queue (pcu)	Mean Max Queue (pcu)																								
Network: Camp Road/Chilgrove Drive Signalisation	-	-	103	0	0	11.9	2.7	0.3	14.8	-	-	-	-																								
Camp Road/Chilgrove Drive	-	-	103	0	0	11.9	2.7	0.3	14.8	-	-	-	-																								
1/1+1/2	177	177	100	0	0	1.7	0.5	0.3	2.5	50.5	2.8	0.5	3.3																								
2/1	52	52	-	-	-	0.3	0.0	-	0.3	21.3	1.1	0.0	1.1																								
2/2	138	138	-	-	-	1.5	0.1	-	1.6	41.5	3.6	0.1	3.8																								
3/1+3/2	377	377	-	-	-	2.6	0.5	-	3.1	29.7	4.9	0.5	5.4																								
4/1+4/2	223	223	3	0	0	1.6	0.2	0.0	1.8	29.6	4.8	0.2	5.1																								
5/1	188	188	-	-	-	0.7	0.4	-	1.1	21.2	1.5	0.4	1.9																								
5/2	216	216	-	-	-	2.1	0.4	-	2.5	41.7	6.5	0.4	6.9																								
6/2+6/1	624	624	-	-	-	1.4	0.5	-	1.9	11.0	7.2	0.5	7.8																								
7/1	727	727	-	-	-	0.0	0.0	-	0.0	0.0	0.0	0.0	0.0																								
8/1	55	55	-	-	-	0.0	0.0	-	0.0	0.0	0.0	0.0	0.0																								
9/1	331	331	-	-	-	0.0	0.0	-	0.0	0.0	0.0	0.0	0.0																								
10/1	288	288	-	-	-	0.0	0.0	-	0.0	0.0	0.0	0.0	0.0																								
<table style="width:100%; border:none;"> <tr> <td style="width:15%;"></td> <td style="width:15%;">C1</td> <td style="width:15%;">PRC for Signalled Lanes (%):</td> <td style="width:15%;">77.4</td> <td style="width:15%;">Total Delay for Signalled Lanes (pcuHr):</td> <td style="width:15%;">7.99</td> <td style="width:15%;">Cycle Time (s):</td> <td style="width:15%;">110</td> </tr> <tr> <td></td> <td>C2</td> <td>PRC for Signalled Lanes (%):</td> <td>80.9</td> <td>Total Delay for Signalled Lanes (pcuHr):</td> <td>6.84</td> <td>Cycle Time (s):</td> <td>110</td> </tr> <tr> <td></td> <td></td> <td>PRC Over All Lanes (%):</td> <td>77.4</td> <td>Total Delay Over All Lanes(pcuHr):</td> <td>14.83</td> <td></td> <td></td> </tr> </table>															C1	PRC for Signalled Lanes (%):	77.4	Total Delay for Signalled Lanes (pcuHr):	7.99	Cycle Time (s):	110		C2	PRC for Signalled Lanes (%):	80.9	Total Delay for Signalled Lanes (pcuHr):	6.84	Cycle Time (s):	110			PRC Over All Lanes (%):	77.4	Total Delay Over All Lanes(pcuHr):	14.83		
	C1	PRC for Signalled Lanes (%):	77.4	Total Delay for Signalled Lanes (pcuHr):	7.99	Cycle Time (s):	110																														
	C2	PRC for Signalled Lanes (%):	80.9	Total Delay for Signalled Lanes (pcuHr):	6.84	Cycle Time (s):	110																														
		PRC Over All Lanes (%):	77.4	Total Delay Over All Lanes(pcuHr):	14.83																																

Scenario 3: '2031 Reference Case + Development AM' (FG3: '2031 Reference Case + Development AM', Plan 1: 'Network Control Plan 1')

C1

Stage Sequence Diagram

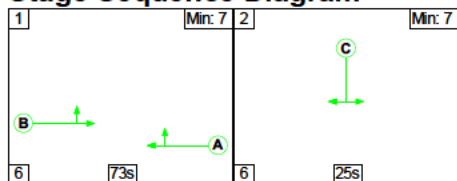

Stage Timings

Stage	1	2
Duration	73	25
Change Point	19	98

Signal Timings Diagram

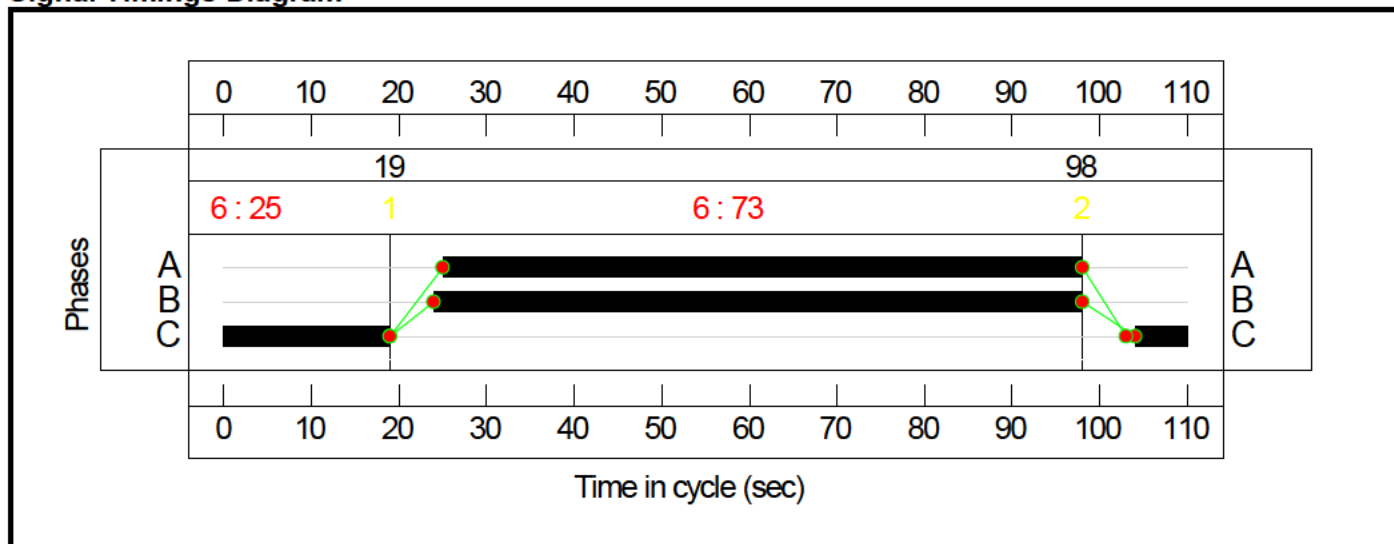

C2

Stage Sequence Diagram

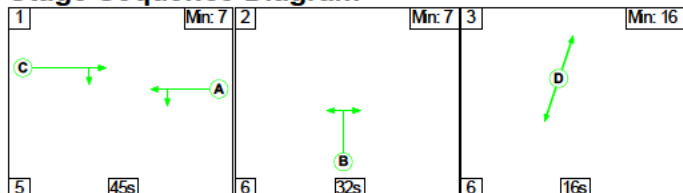

Stage Timings

Stage	1	2	3
Duration	45	32	16
Change Point	67	7	45

Signal Timings Diagram

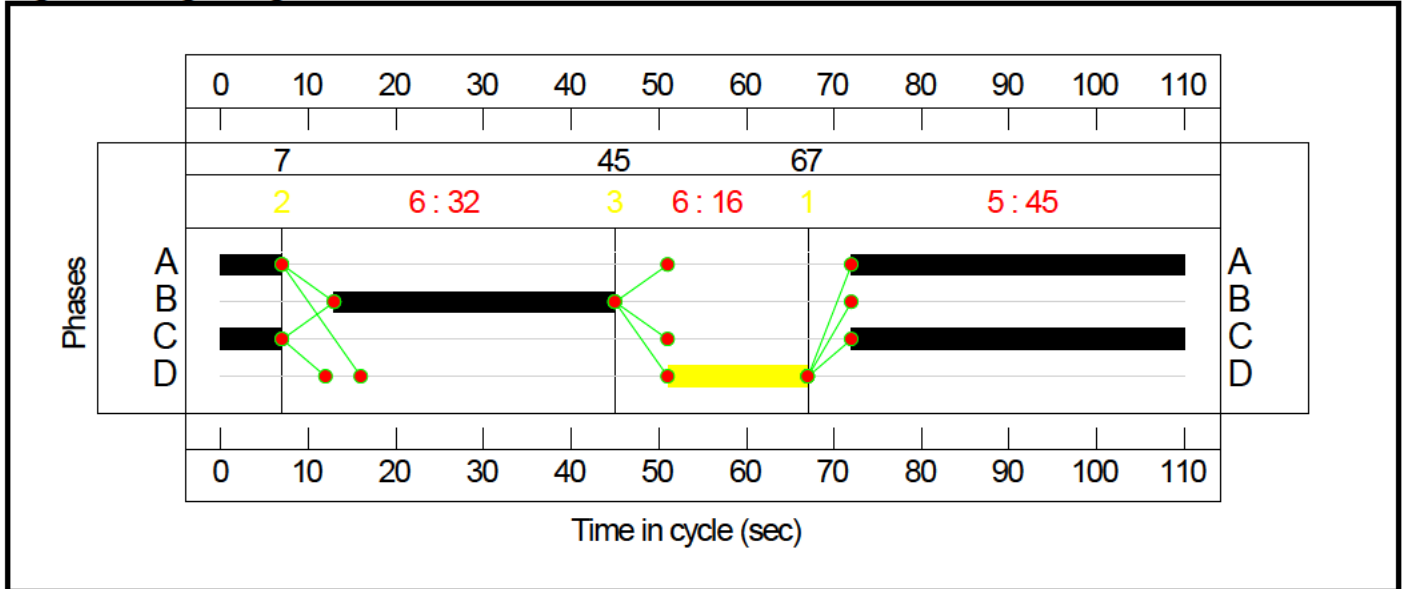

Network Layout Diagram

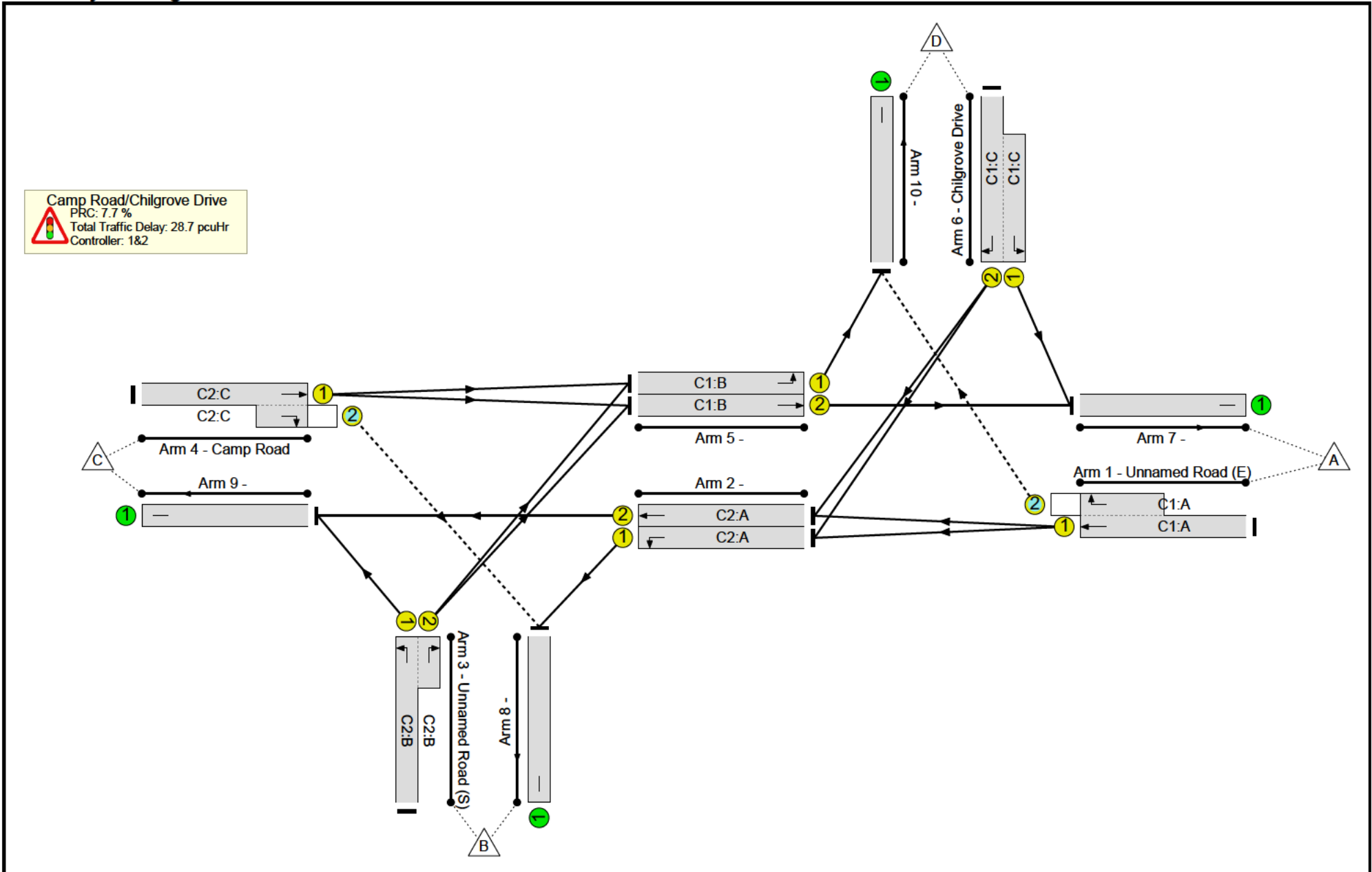

Network Results

Item	Lane Description	Lane Type	Controller Stream	Position In Filtered Route	Full Phase	Arrow Phase	Num Greens	Total Green (s)	Arrow Green (s)	Demand Flow (pcu)	Sat Flow (pcu/Hr)	Capacity (pcu)	Deg Sat (%)
Network: Camp Road/Chilgrove Drive Signalisation	-	-	N/A	-	-		-	-	-	-	-	-	83.6%
Camp Road/Chilgrove Drive	-	-	N/A	-	-		-	-	-	-	-	-	83.6%
1/1+1/2	Unnamed Road (E) Ahead Right	U+O	N/A	N/A	C1:A		1	73	-	427	1965:1786	102+471	74.6 : 74.6%
2/1	Left	U	N/A	N/A	C2:A		1	45	-	23	1709	715	3.2%
2/2	Ahead	U	N/A	N/A	C2:A		1	45	-	93	1965	822	11.3%
3/1+3/2	Unnamed Road (S) Right Left	U	N/A	N/A	C2:B		1	32	-	492	1709:1786	199+398	82.4 : 82.4%
4/1+4/2	Camp Road Ahead Right	U+O	N/A	N/A	C2:C		1	45	-	702	1965:1786	808+32	83.6 : 83.6%
5/1	Left	U	N/A	N/A	C1:B		1	74	-	378	1709	1165	32.4%
5/2	Ahead	U	N/A	N/A	C1:B		1	74	-	625	1965	1340	46.6%
6/2+6/1	Chilgrove Drive Right Left	U	N/A	N/A	C1:C		1	25	-	355	1786:1709	51+400	78.7 : 78.7%
7/1		U	N/A	N/A	-		-	-	-	940	Inf	Inf	0.0%
8/1		U	N/A	N/A	-		-	-	-	50	Inf	Inf	0.0%
9/1		U	N/A	N/A	-		-	-	-	257	Inf	Inf	0.0%
10/1		U	N/A	N/A	-		-	-	-	729	Inf	Inf	0.0%

Item	Arriving (pcu)	Leaving (pcu)	Turners In Gaps (pcu)	Turners When Unopposed (pcu)	Turners In Intergreen (pcu)	Uniform Delay (pcuHr)	Rand + Oversat Delay (pcuHr)	Storage Area Uniform Delay (pcuHr)	Total Delay (pcuHr)	Av. Delay Per PCU (s/pcu)	Max. Back of Uniform Queue (pcu)	Rand + Oversat Queue (pcu)	Mean Max Queue (pcu)																								
Network: Camp Road/Chilgrove Drive Signalisation	-	-	313	0	65	19.3	8.7	0.8	28.7	-	-	-	-																								
Camp Road/Chilgrove Drive	-	-	313	0	65	19.3	8.7	0.8	28.7	-	-	-	-																								
1/1+1/2	427	427	286	0	65	1.5	1.4	0.8	3.7	31.3	7.0	1.4	8.5																								
2/1	23	23	-	-	-	0.1	0.0	-	0.1	13.0	0.1	0.0	0.1																								
2/2	93	93	-	-	-	0.5	0.1	-	0.6	21.9	1.8	0.1	1.8																								
3/1+3/2	492	492	-	-	-	4.6	2.2	-	6.9	50.4	11.9	2.2	14.2																								
4/1+4/2	702	702	27	0	0	5.5	2.5	0.0	8.0	41.0	18.8	2.5	21.2																								
5/1	378	378	-	-	-	0.6	0.2	-	0.9	8.2	9.3	0.2	9.5																								
5/2	625	625	-	-	-	2.6	0.4	-	3.0	17.5	9.1	0.4	9.6																								
6/2+6/1	355	355	-	-	-	3.8	1.8	-	5.6	56.7	9.0	1.8	10.8																								
7/1	940	940	-	-	-	0.0	0.0	-	0.0	0.0	0.0	0.0	0.0																								
8/1	50	50	-	-	-	0.0	0.0	-	0.0	0.0	0.0	0.0	0.0																								
9/1	257	257	-	-	-	0.0	0.0	-	0.0	0.0	0.0	0.0	0.0																								
10/1	729	729	-	-	-	0.0	0.0	-	0.0	0.0	0.0	0.0	0.0																								
<table style="width:100%; border:none;"> <tr> <td style="width:15%;"></td> <td style="width:15%;">C1</td> <td style="width:15%;">PRC for Signalled Lanes (%):</td> <td style="width:15%;">14.3</td> <td style="width:15%;">Total Delay for Signalled Lanes (pcuHr):</td> <td style="width:15%;">13.20</td> <td style="width:15%;">Cycle Time (s):</td> <td style="width:15%;">110</td> </tr> <tr> <td></td> <td>C2</td> <td>PRC for Signalled Lanes (%):</td> <td>7.7</td> <td>Total Delay for Signalled Lanes (pcuHr):</td> <td>15.53</td> <td>Cycle Time (s):</td> <td>110</td> </tr> <tr> <td></td> <td></td> <td>PRC Over All Lanes (%):</td> <td>7.7</td> <td>Total Delay Over All Lanes(pcuHr):</td> <td>28.73</td> <td></td> <td></td> </tr> </table>															C1	PRC for Signalled Lanes (%):	14.3	Total Delay for Signalled Lanes (pcuHr):	13.20	Cycle Time (s):	110		C2	PRC for Signalled Lanes (%):	7.7	Total Delay for Signalled Lanes (pcuHr):	15.53	Cycle Time (s):	110			PRC Over All Lanes (%):	7.7	Total Delay Over All Lanes(pcuHr):	28.73		
	C1	PRC for Signalled Lanes (%):	14.3	Total Delay for Signalled Lanes (pcuHr):	13.20	Cycle Time (s):	110																														
	C2	PRC for Signalled Lanes (%):	7.7	Total Delay for Signalled Lanes (pcuHr):	15.53	Cycle Time (s):	110																														
		PRC Over All Lanes (%):	7.7	Total Delay Over All Lanes(pcuHr):	28.73																																

Scenario 4: '2031 Reference Case + Development PM' (FG4: '2031 Reference Case + Development PM', Plan 1: 'Network Control Plan 1')

C1

Stage Sequence Diagram

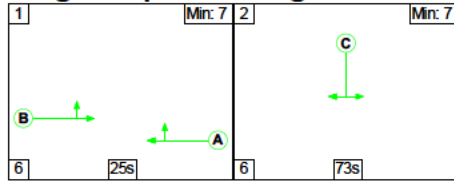

Stage Timings

Stage	1	2
Duration	25	73
Change Point	0	31

Signal Timings Diagram

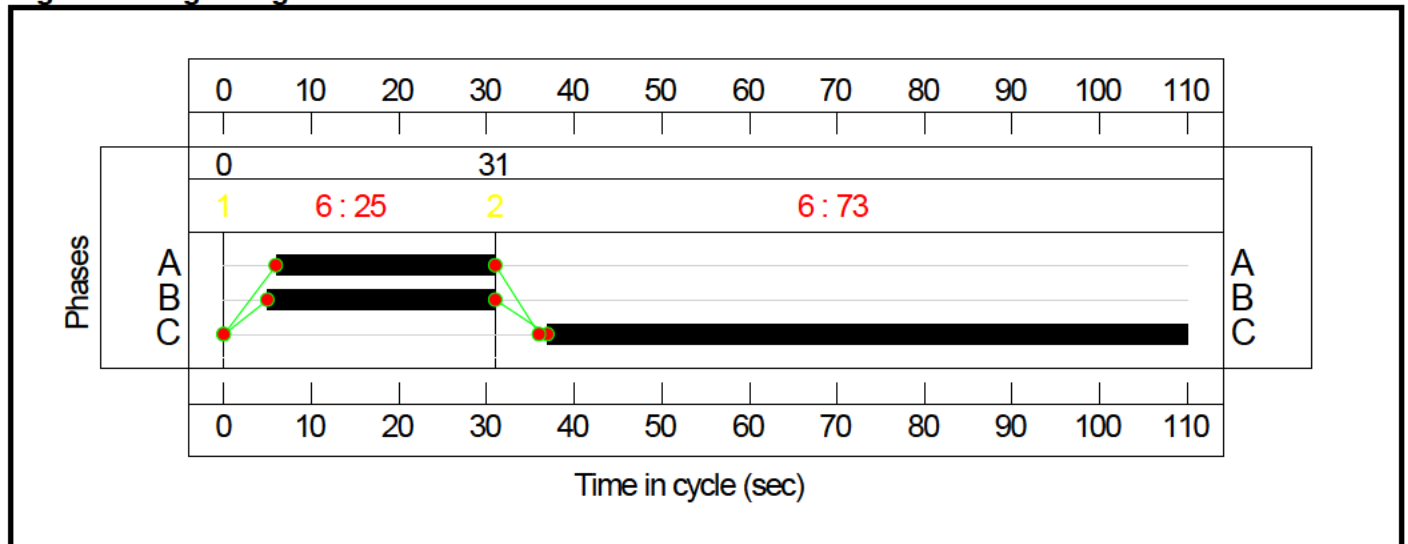

C2

Stage Sequence Diagram

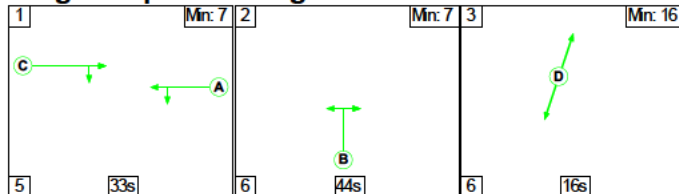

Stage Timings

Stage	1	2	3
Duration	33	44	16
Change Point	42	80	20

Signal Timings Diagram

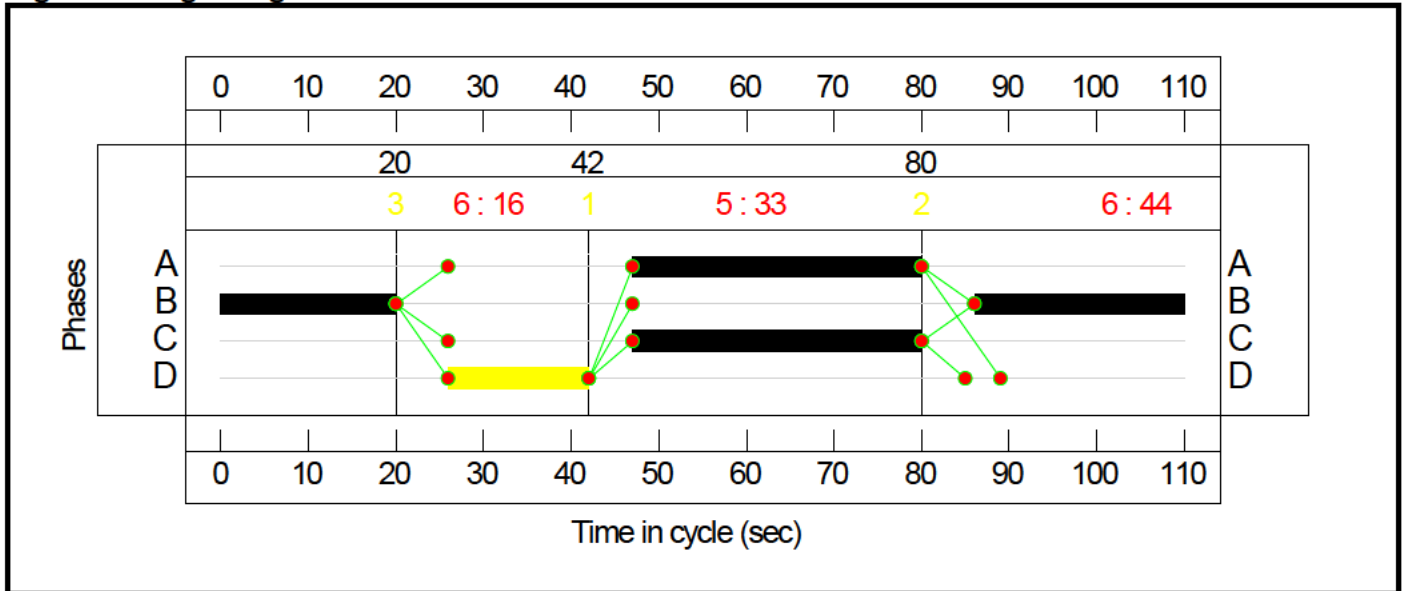

Network Layout Diagram

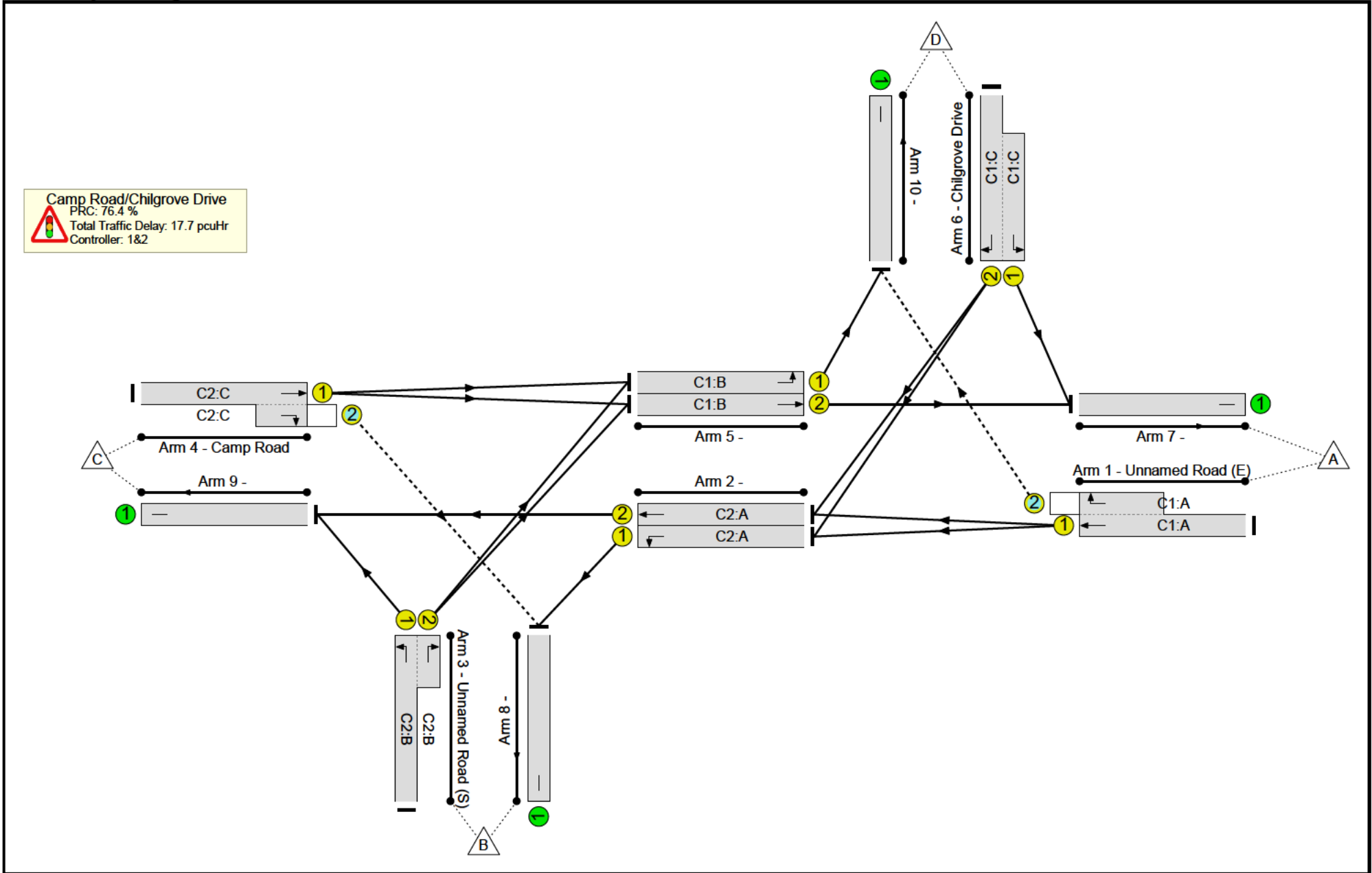

Network Results

Item	Lane Description	Lane Type	Controller Stream	Position In Filtered Route	Full Phase	Arrow Phase	Num Greens	Total Green (s)	Arrow Green (s)	Demand Flow (pcu)	Sat Flow (pcu/Hr)	Capacity (pcu)	Deg Sat (%)
Network: Camp Road/Chilgrove Drive Signalisation	-	-	N/A	-	-		-	-	-	-	-	-	51.0%
Camp Road/Chilgrove Drive	-	-	N/A	-	-		-	-	-	-	-	-	51.0%
1/1+1/2	Unnamed Road (E) Ahead Right	U+O	N/A	N/A	C1:A		1	25	-	197	1965:1786	187+201	50.7 : 50.7%
2/1	Left	U	N/A	N/A	C2:A		1	33	-	52	1709	528	9.8%
2/2	Ahead	U	N/A	N/A	C2:A		1	33	-	161	1965	607	26.5%
3/1+3/2	Unnamed Road (S) Right Left	U	N/A	N/A	C2:B		1	44	-	416	1709:1786	457+359	51.0 : 51.0%
4/1+4/2	Camp Road Ahead Right	U+O	N/A	N/A	C2:C		1	33	-	249	1965:1786	607+18	39.8 : 39.8%
5/1	Left	U	N/A	N/A	C1:B		1	26	-	188	1709	419	44.8%
5/2	Ahead	U	N/A	N/A	C1:B		1	26	-	237	1965	482	49.1%
6/2+6/1	Chilgrove Drive Right Left	U	N/A	N/A	C1:C		1	73	-	629	1786:1709	231+1002	51.0 : 51.0%
7/1		U	N/A	N/A	-		-	-	-	748	Inf	Inf	0.0%
8/1		U	N/A	N/A	-		-	-	-	59	Inf	Inf	0.0%
9/1		U	N/A	N/A	-		-	-	-	394	Inf	Inf	0.0%
10/1		U	N/A	N/A	-		-	-	-	290	Inf	Inf	0.0%

Item	Arriving (pcu)	Leaving (pcu)	Turners In Gaps (pcu)	Turners When Unopposed (pcu)	Turners In Intergreen (pcu)	Uniform Delay (pcuHr)	Rand + Oversat Delay (pcuHr)	Storage Area Uniform Delay (pcuHr)	Total Delay (pcuHr)	Av. Delay Per PCU (s/pcu)	Max. Back of Uniform Queue (pcu)	Rand + Oversat Queue (pcu)	Mean Max Queue (pcu)																								
Network: Camp Road/Chilgrove Drive Signalisation	-	-	109	0	0	14.4	3.0	0.3	17.7	-	-	-	-																								
Camp Road/Chilgrove Drive	-	-	109	0	0	14.4	3.0	0.3	17.7	-	-	-	-																								
1/1+1/2	197	197	102	0	0	1.9	0.5	0.3	2.7	49.4	2.9	0.5	3.4																								
2/1	52	52	-	-	-	0.3	0.1	-	0.4	24.8	1.1	0.1	1.2																								
2/2	161	161	-	-	-	1.3	0.2	-	1.5	33.1	4.4	0.2	4.6																								
3/1+3/2	416	416	-	-	-	2.6	0.5	-	3.1	26.6	6.0	0.5	6.6																								
4/1+4/2	249	249	7	0	0	2.1	0.3	0.0	2.4	34.8	5.8	0.3	6.1																								
5/1	188	188	-	-	-	1.1	0.4	-	1.5	28.9	5.1	0.4	5.6																								
5/2	237	237	-	-	-	3.7	0.5	-	4.2	64.0	7.2	0.5	7.7																								
6/2+6/1	629	629	-	-	-	1.4	0.5	-	1.9	11.0	7.2	0.5	7.8																								
7/1	748	748	-	-	-	0.0	0.0	-	0.0	0.0	0.0	0.0	0.0																								
8/1	59	59	-	-	-	0.0	0.0	-	0.0	0.0	0.0	0.0	0.0																								
9/1	394	394	-	-	-	0.0	0.0	-	0.0	0.0	0.0	0.0	0.0																								
10/1	290	290	-	-	-	0.0	0.0	-	0.0	0.0	0.0	0.0	0.0																								
<table style="width:100%; border:none;"> <tr> <td style="width:15%;"></td> <td style="width:15%;">C1</td> <td style="width:15%;">PRC for Signalled Lanes (%):</td> <td style="width:15%;">76.4</td> <td style="width:15%;">Total Delay for Signalled Lanes (pcuHr):</td> <td style="width:15%;">10.34</td> <td style="width:15%;">Cycle Time (s):</td> <td style="width:15%;">110</td> </tr> <tr> <td></td> <td>C2</td> <td>PRC for Signalled Lanes (%):</td> <td>76.6</td> <td>Total Delay for Signalled Lanes (pcuHr):</td> <td>7.32</td> <td>Cycle Time (s):</td> <td>110</td> </tr> <tr> <td></td> <td></td> <td>PRC Over All Lanes (%):</td> <td>76.4</td> <td>Total Delay Over All Lanes(pcuHr):</td> <td>17.66</td> <td></td> <td></td> </tr> </table>															C1	PRC for Signalled Lanes (%):	76.4	Total Delay for Signalled Lanes (pcuHr):	10.34	Cycle Time (s):	110		C2	PRC for Signalled Lanes (%):	76.6	Total Delay for Signalled Lanes (pcuHr):	7.32	Cycle Time (s):	110			PRC Over All Lanes (%):	76.4	Total Delay Over All Lanes(pcuHr):	17.66		
	C1	PRC for Signalled Lanes (%):	76.4	Total Delay for Signalled Lanes (pcuHr):	10.34	Cycle Time (s):	110																														
	C2	PRC for Signalled Lanes (%):	76.6	Total Delay for Signalled Lanes (pcuHr):	7.32	Cycle Time (s):	110																														
		PRC Over All Lanes (%):	76.4	Total Delay Over All Lanes(pcuHr):	17.66																																

T19562
Heyford Park



Appendix G

LinSig Output – B430/Unnamed Road

Full Input Data And Results

User and Project Details

Project:	Heyford Park
Title:	B430/Unnamed Road Signalisation
Location:	
Client:	Richborough Estates
Site Ref(s):	T19562
Date Started:	24/11/2021
Additional detail:	
File name:	T19562 - B430-Unnamed Road.lsg3x
Author:	Max Law
Company:	Hub Transport Planning Ltd
Address:	Radclyffe House, 66/68 Hagley Road, Edgbaston, Birmingham, West Midlands, B16 8PF

Network Layout Diagram

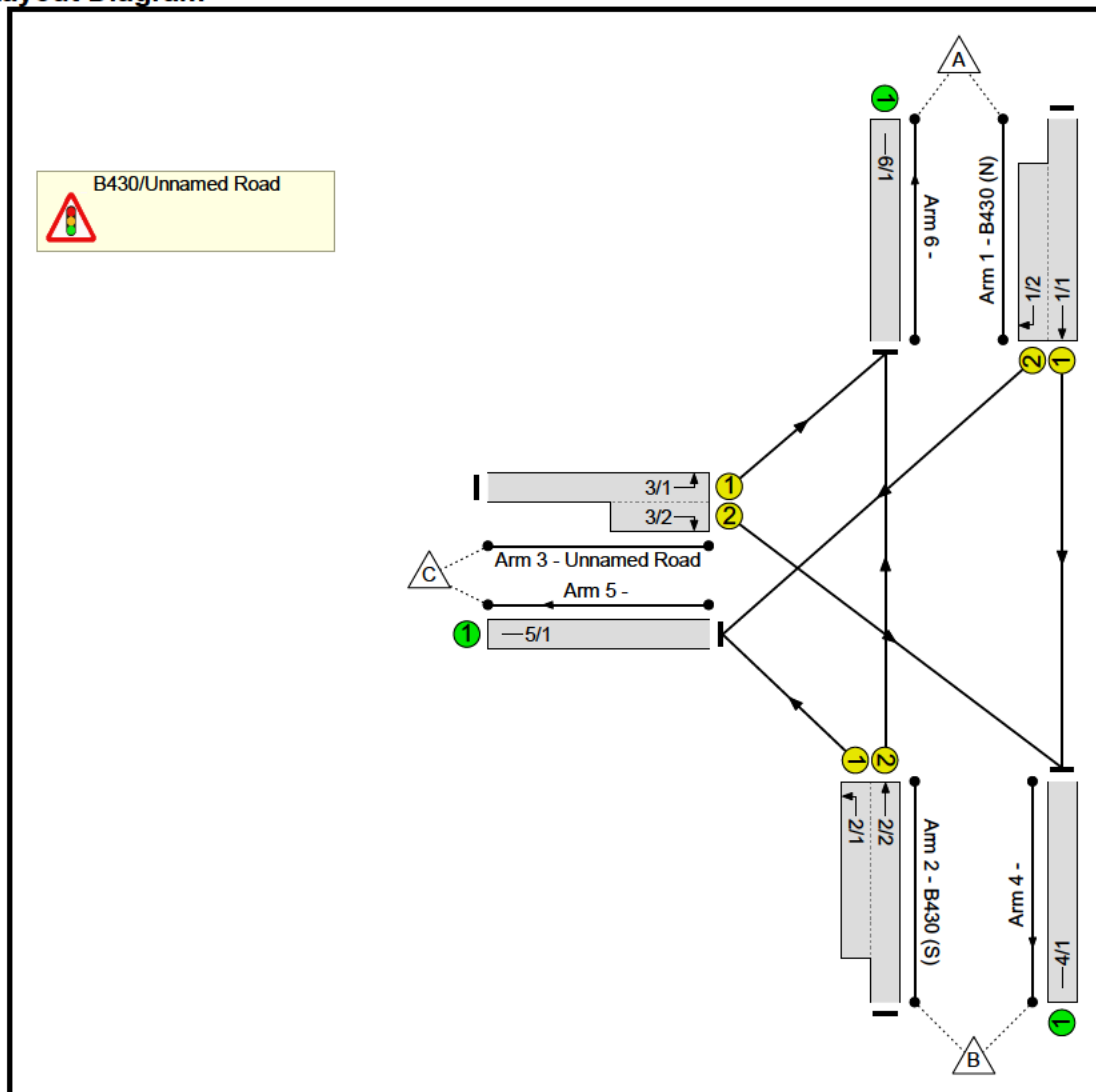

Phase Diagram

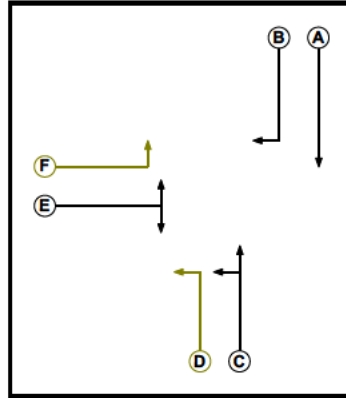

Phase Input Data

Phase Name	Phase Type	Assoc. Phase	Street Min	Cont Min
A	Traffic		7	7
B	Traffic		7	7
C	Traffic		7	7
D	Filter	C	4	0
E	Traffic		7	7
F	Filter	E	4	0

Phase Intergreens Matrix

		Starting Phase					
		A	B	C	D	E	F
Terminating Phase	A	-	-	-	5	-	-
	B	-	-	5	6	5	-
	C	-	5	-	-	5	6
	D	-	5	-	-	-	-
	E	5	5	5	-	-	-
	F	-	-	5	-	-	-

Phases in Stage

Stage No.	Phases in Stage
1	A C
2	A B F
3	D E

Stage Diagram

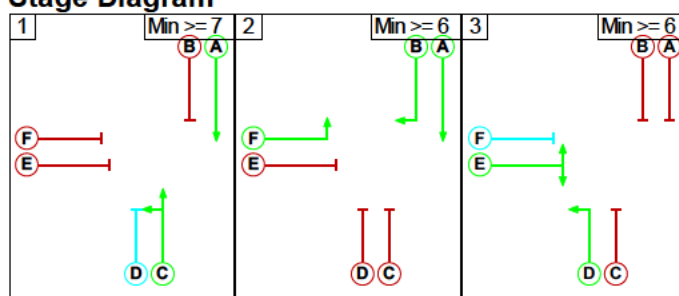

Phase Delays

Term. Stage	Start Stage	Phase	Type	Value	Cont value
There are no Phase Delays defined					

Prohibited Stage Change

		To Stage		
		1	2	3
From Stage	1		6	5
	2	X		6
	3	5	X	

Give-Way Lane Input Data

Junction: B430/Unnamed Road
There are no Opposed Lanes in this Junction

Lane Input Data

Junction: B430/Unnamed Road												
Lane	Lane Type	Phases	Start Disp.	End Disp.	Physical Length (PCU)	Sat Flow Type	Def User Saturation Flow (PCU/Hr)	Lane Width (m)	Gradient	Nearside Lane	Turns	Turning Radius (m)
1/1 (B430 (N))	U	A	2	3	60.0	Geom	-	3.65	0.00	Y	Arm 4 Ahead	Inf
1/2 (B430 (N))	U	B	2	3	28.5	Geom	-	3.65	0.00	Y	Arm 5 Right	15.00
2/1 (B430 (S))	U	C D	2	3	12.9	Geom	-	3.65	0.00	Y	Arm 5 Left	10.00
2/2 (B430 (S))	U	C	2	3	60.0	Geom	-	3.65	0.00	Y	Arm 6 Ahead	Inf
3/1 (Unnamed Road)	U	E F	2	3	60.0	Geom	-	3.25	0.00	Y	Arm 6 Left	15.00
3/2 (Unnamed Road)	U	E	2	3	5.0	Geom	-	3.25	0.00	Y	Arm 4 Right	20.00
4/1	U		2	3	60.0	Inf	-	-	-	-	-	-
5/1	U		2	3	60.0	Inf	-	-	-	-	-	-
6/1	U		2	3	60.0	Inf	-	-	-	-	-	-

Traffic Flow Groups

Flow Group	Start Time	End Time	Duration	Formula
1: '2031 Reference Case AM'	08:00	09:00	01:00	
2: '2031 Reference Case PM'	17:00	18:00	01:00	
3: '2031 Reference Case + Development AM'	08:00	09:00	01:00	
4: '2031 Reference Case + Development PM'	17:00	18:00	01:00	

Scenario 1: '2031 Reference Case AM' (FG1: '2031 Reference Case AM', Plan 1: 'Network Control Plan 1')

Traffic Flows, Desired

Desired Flow :

Origin	Destination				Tot.
	A	B	C	Tot.	
A	0	734	415	1149	
B	128	0	0	128	
C	352	538	0	890	
Tot.	480	1272	415	2167	

Traffic Lane Flows

Lane	Scenario 1: 2031 Reference Case AM
Junction: B430/Unnamed Road	
1/1 (with short)	1149(In) 734(Out)
1/2 (short)	415
2/1 (short)	0
2/2 (with short)	128(In) 128(Out)
3/1 (with short)	890(In) 352(Out)
3/2 (short)	538
4/1	1272
5/1	415
6/1	480

Lane Saturation Flows

Junction: B430/Unnamed Road								
Lane	Lane Width (m)	Gradient	Nearside Lane	Allowed Turns	Turning Radius (m)	Turning Prop.	Sat Flow (PCU/Hr)	Flared Sat Flow (PCU/Hr)
1/1 (B430 (N))	3.65	0.00	Y	Arm 4 Ahead	Inf	100.0 %	1980	1980
1/2 (B430 (N))	3.65	0.00	Y	Arm 5 Right	15.00	100.0 %	1800	1800
2/1 (B430 (S))	3.65	0.00	Y	Arm 5 Left	10.00	0.0 %	1980	1980
2/2 (B430 (S))	3.65	0.00	Y	Arm 6 Ahead	Inf	100.0 %	1980	1980
3/1 (Unnamed Road)	3.25	0.00	Y	Arm 6 Left	15.00	100.0 %	1764	1764
3/2 (Unnamed Road)	3.25	0.00	Y	Arm 4 Right	20.00	100.0 %	1805	1805
4/1	Infinite Saturation Flow						Inf	Inf
5/1	Infinite Saturation Flow						Inf	Inf
6/1	Infinite Saturation Flow						Inf	Inf

Scenario 2: '2031 Reference Case PM' (FG2: '2031 Reference Case PM', Plan 1: 'Network Control Plan 1')

Traffic Flows, Desired

Desired Flow :

		Destination			
		A	B	C	Tot.
Origin	A	0	622	176	798
	B	328	0	0	328
	C	348	383	0	731
	Tot.	676	1005	176	1857

Traffic Lane Flows

Lane	Scenario 2: 2031 Reference Case PM
Junction: B430/Unnamed Road	
1/1 (with short)	798(In) 622(Out)
1/2 (short)	176
2/1 (short)	0
2/2 (with short)	328(In) 328(Out)
3/1 (with short)	731(In) 348(Out)
3/2 (short)	383
4/1	1005
5/1	176
6/1	676

Lane Saturation Flows

Junction: B430/Unnamed Road								
Lane	Lane Width (m)	Gradient	Nearside Lane	Allowed Turns	Turning Radius (m)	Turning Prop.	Sat Flow (PCU/Hr)	Flared Sat Flow (PCU/Hr)
1/1 (B430 (N))	3.65	0.00	Y	Arm 4 Ahead	Inf	100.0 %	1980	1980
1/2 (B430 (N))	3.65	0.00	Y	Arm 5 Right	15.00	100.0 %	1800	1800
2/1 (B430 (S))	3.65	0.00	Y	Arm 5 Left	10.00	0.0 %	1980	1980
2/2 (B430 (S))	3.65	0.00	Y	Arm 6 Ahead	Inf	100.0 %	1980	1980
3/1 (Unnamed Road)	3.25	0.00	Y	Arm 6 Left	15.00	100.0 %	1764	1764
3/2 (Unnamed Road)	3.25	0.00	Y	Arm 4 Right	20.00	100.0 %	1805	1805
4/1	Infinite Saturation Flow						Inf	Inf
5/1	Infinite Saturation Flow						Inf	Inf
6/1	Infinite Saturation Flow						Inf	Inf

Scenario 3: '2031 Ref Case + Development AM' (FG3: '2031 Reference Case + Development AM', Plan 1: 'Network Control Plan 1')

Traffic Flows, Desired

Desired Flow :

	Destination				
	A	B	C	Tot.	
Origin	A	0	724	425	1149
	B	124	0	0	124
	C	378	566	0	944
	Tot.	502	1290	425	2217

Traffic Lane Flows

Lane	Scenario 3: 2031 Ref Case + Development AM
Junction: B430/Unnamed Road	
1/1 (with short)	1149(In) 724(Out)
1/2 (short)	425
2/1 (short)	0
2/2 (with short)	124(In) 124(Out)
3/1 (with short)	944(In) 378(Out)
3/2 (short)	566
4/1	1290
5/1	425
6/1	502

Lane Saturation Flows

Junction: B430/Unnamed Road								
Lane	Lane Width (m)	Gradient	Nearside Lane	Allowed Turns	Turning Radius (m)	Turning Prop.	Sat Flow (PCU/Hr)	Flared Sat Flow (PCU/Hr)
1/1 (B430 (N))	3.65	0.00	Y	Arm 4 Ahead	Inf	100.0 %	1980	1980
1/2 (B430 (N))	3.65	0.00	Y	Arm 5 Right	15.00	100.0 %	1800	1800
2/1 (B430 (S))	3.65	0.00	Y	Arm 5 Left	10.00	0.0 %	1980	1980
2/2 (B430 (S))	3.65	0.00	Y	Arm 6 Ahead	Inf	100.0 %	1980	1980
3/1 (Unnamed Road)	3.25	0.00	Y	Arm 6 Left	15.00	100.0 %	1764	1764
3/2 (Unnamed Road)	3.25	0.00	Y	Arm 4 Right	20.00	100.0 %	1805	1805
4/1	Infinite Saturation Flow						Inf	Inf
5/1	Infinite Saturation Flow						Inf	Inf
6/1	Infinite Saturation Flow						Inf	Inf

Scenario 4: '2031 Ref Case + Development PM' (FG4: '2031 Reference Case + Development PM', Plan 1: 'Network Control Plan 1')

Traffic Flows, Desired

Desired Flow :

		Destination			
		A	B	C	Tot.
Origin	A	0	612	197	809
	B	319	0	0	319
	C	356	396	0	752
	Tot.	675	1008	197	1880

Traffic Lane Flows

Lane	Scenario 4: 2031 Ref Case + Development PM
Junction: B430/Unnamed Road	
1/1 (with short)	809(In) 612(Out)
1/2 (short)	197
2/1 (short)	0
2/2 (with short)	319(In) 319(Out)
3/1 (with short)	752(In) 356(Out)
3/2 (short)	396
4/1	1008
5/1	197
6/1	675

Lane Saturation Flows

Junction: B430/Unnamed Road								
Lane	Lane Width (m)	Gradient	Nearside Lane	Allowed Turns	Turning Radius (m)	Turning Prop.	Sat Flow (PCU/Hr)	Flared Sat Flow (PCU/Hr)
1/1 (B430 (N))	3.65	0.00	Y	Arm 4 Ahead	Inf	100.0 %	1980	1980
1/2 (B430 (N))	3.65	0.00	Y	Arm 5 Right	15.00	100.0 %	1800	1800
2/1 (B430 (S))	3.65	0.00	Y	Arm 5 Left	10.00	0.0 %	1980	1980
2/2 (B430 (S))	3.65	0.00	Y	Arm 6 Ahead	Inf	100.0 %	1980	1980
3/1 (Unnamed Road)	3.25	0.00	Y	Arm 6 Left	15.00	100.0 %	1764	1764
3/2 (Unnamed Road)	3.25	0.00	Y	Arm 4 Right	20.00	100.0 %	1805	1805
4/1	Infinite Saturation Flow						Inf	Inf
5/1	Infinite Saturation Flow						Inf	Inf
6/1	Infinite Saturation Flow						Inf	Inf

Scenario 1: '2031 Reference Case AM' (FG1: '2031 Reference Case AM', Plan 1: 'Network Control Plan 1')

Stage Sequence Diagram

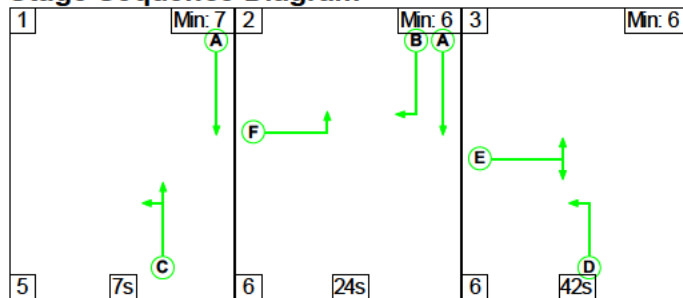

Stage Timings

Stage	1	2	3
Duration	7	24	42
Change Point	0	12	42

Signal Timings Diagram

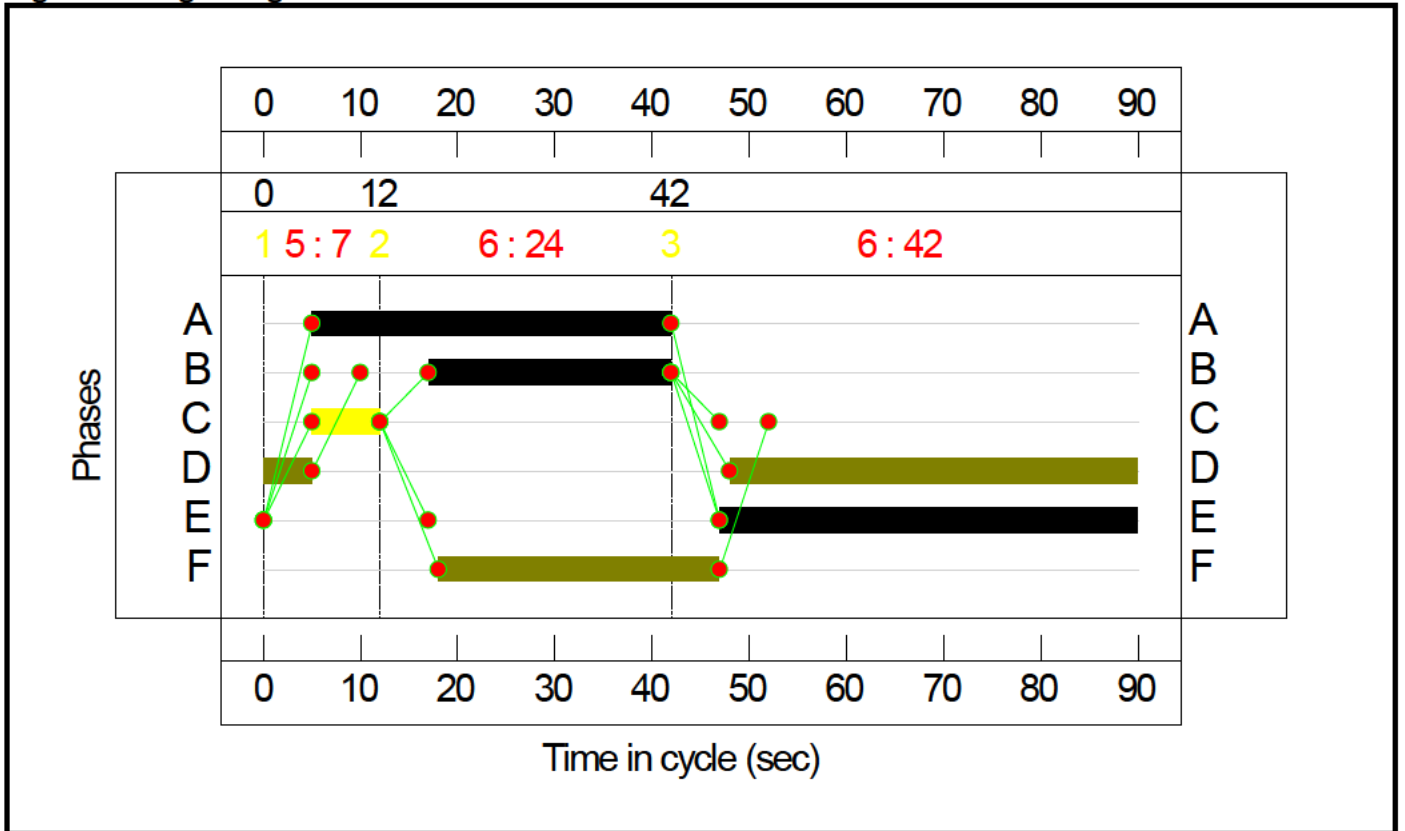

Network Layout Diagram

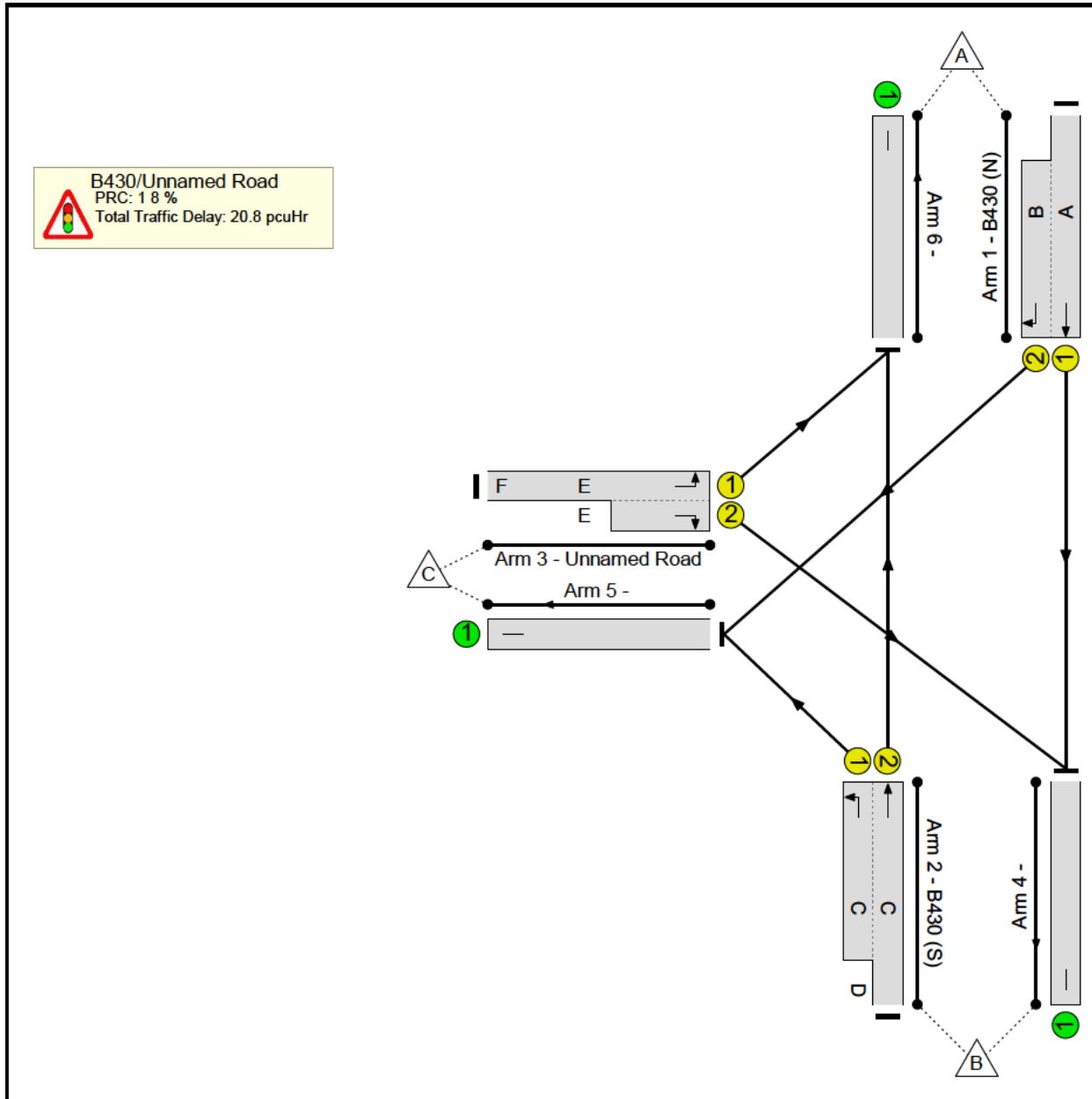

Network Results

Item	Lane Description	Lane Type	Controller Stream	Position In Filtered Route	Full Phase	Arrow Phase	Num Greens	Total Green (s)	Arrow Green (s)	Demand Flow (pcu)	Sat Flow (pcu/Hr)	Capacity (pcu)	Deg Sat (%)
Network: B430/Unnamed Road Signalisation	-	-	N/A	-	-		-	-	-	-	-	-	88.4%
B430/Unnamed Road	-	-	N/A	-	-		-	-	-	-	-	-	88.4%
1/1+1/2	B430 (N) Ahead Right	U	N/A	N/A	A B		1	37:25	-	1149	1980:1800	836+520	87.8 : 79.8%
2/2+2/1	B430 (S) Left Ahead	U	N/A	N/A	C	D	1	7:54	47	128	1980:1980	176+0	72.7 : 0.0%
3/1+3/2	Unnamed Road Right Left	U	N/A	N/A	E	F	1	72:43	29	890	1764:1805	398+608	88.4 : 88.4%
4/1		U	N/A	N/A	-		-	-	-	1272	Inf	Inf	0.0%
5/1		U	N/A	N/A	-		-	-	-	415	Inf	Inf	0.0%
6/1		U	N/A	N/A	-		-	-	-	480	Inf	Inf	0.0%
Item	Arriving (pcu)	Leaving (pcu)	Turners In Gaps (pcu)	Turners When Unopposed (pcu)	Turners In Intergreen (pcu)	Uniform Delay (pcuHr)	Rand + Oversat Delay (pcuHr)	Storage Area Uniform Delay (pcuHr)	Total Delay (pcuHr)	Av. Delay Per PCU (s/pcu)	Max. Back of Uniform Queue (pcu)	Rand + Oversat Queue (pcu)	Mean Max Queue (pcu)
Network: B430/Unnamed Road Signalisation	-	-	0	0	0	13.2	7.6	0.0	20.8	-	-	-	-
B430/Unnamed Road	-	-	0	0	0	13.2	7.6	0.0	20.8	-	-	-	-
1/1+1/2	1149	1149	-	-	-	8.3	2.7	-	11.0	34.4	16.7	2.7	19.4
2/2+2/1	128	128	-	-	-	1.4	1.3	-	2.7	75.6	3.1	1.3	4.4
3/1+3/2	890	890	-	-	-	3.5	3.6	-	7.1	28.7	16.1	3.6	19.7
4/1	1272	1272	-	-	-	0.0	0.0	-	0.0	0.0	0.0	0.0	0.0
5/1	415	415	-	-	-	0.0	0.0	-	0.0	0.0	0.0	0.0	0.0
6/1	480	480	-	-	-	0.0	0.0	-	0.0	0.0	0.0	0.0	0.0
C1			PRC for Signalled Lanes (%):		1.8	Total Delay for Signalled Lanes (pcuHr):		20.76	Cycle Time (s):		90		
			PRC Over All Lanes (%):		1.8	Total Delay Over All Lanes(pcuHr):		20.76					

Scenario 2: '2031 Reference Case PM' (FG2: '2031 Reference Case PM', Plan 1: 'Network Control Plan 1')

Stage Sequence Diagram

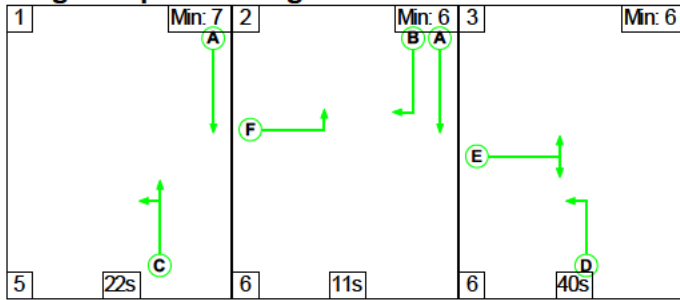

Stage Timings

Stage	1	2	3
Duration	22	11	40
Change Point	0	27	44

Signal Timings Diagram

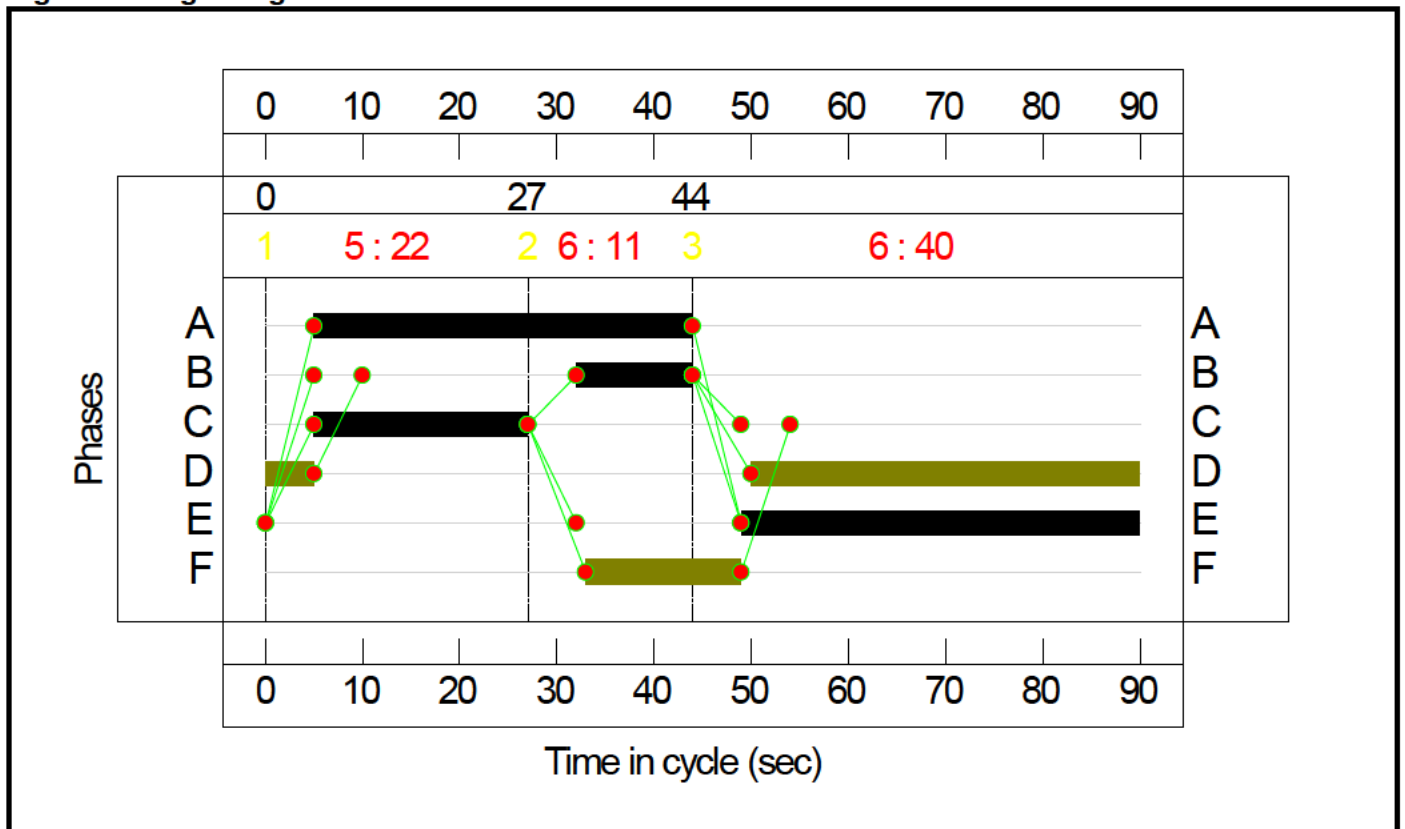

Network Layout Diagram

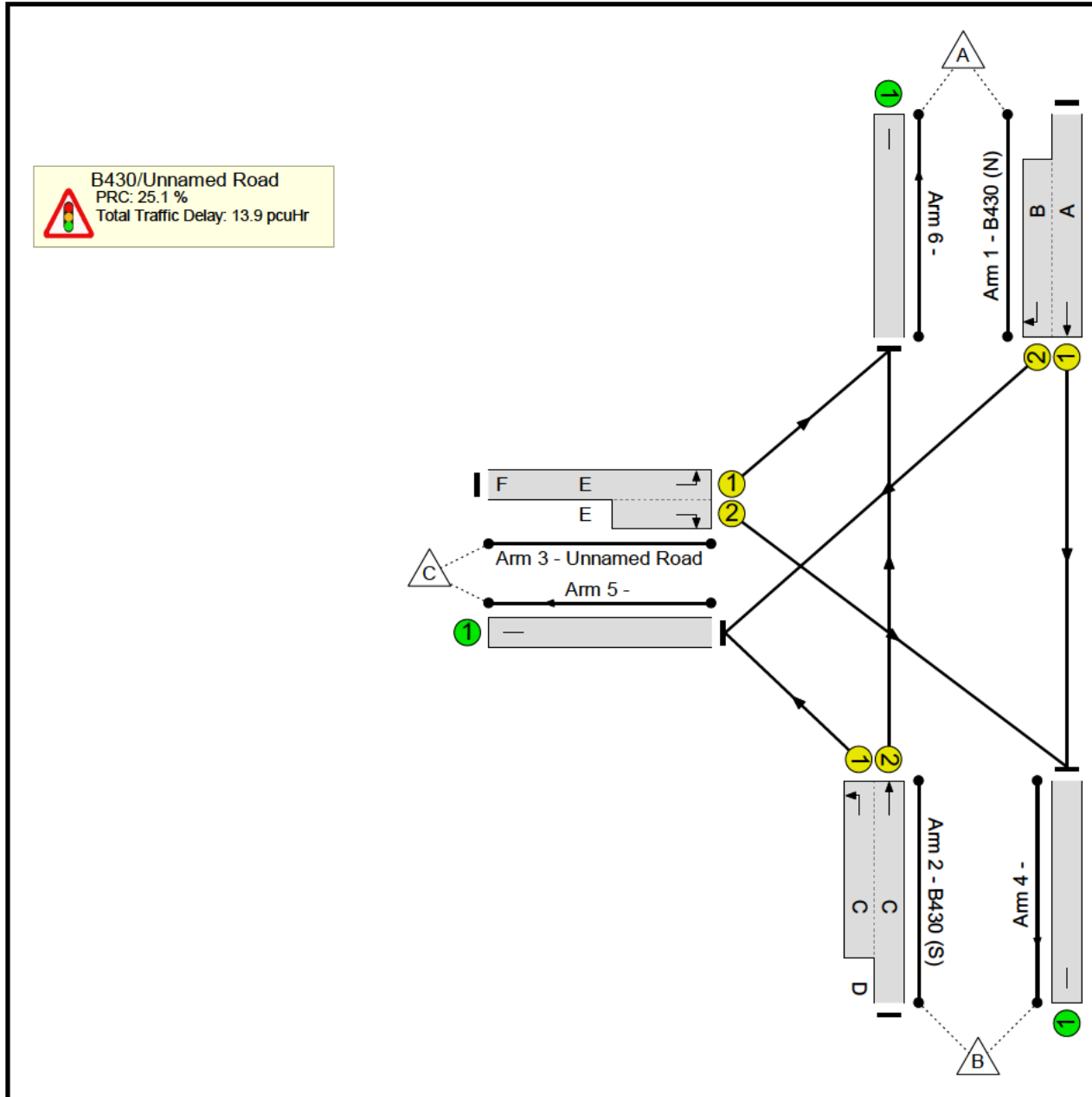

Network Results

Item	Lane Description	Lane Type	Controller Stream	Position In Filtered Route	Full Phase	Arrow Phase	Num Greens	Total Green (s)	Arrow Green (s)	Demand Flow (pcu)	Sat Flow (pcu/Hr)	Capacity (pcu)	Deg Sat (%)
Network: B430/Unnamed Road Signalisation	-	-	N/A	-	-		-	-	-	-	-	-	71.9%
B430/Unnamed Road	-	-	N/A	-	-		-	-	-	-	-	-	71.9%
1/1+1/2	B430 (N) Ahead Right	U	N/A	N/A	A B		1	39:12	-	798	1980:1800	880+260	70.7 : 67.7%
2/2+2/1	B430 (S) Left Ahead	U	N/A	N/A	C	D	1	22:67	45	328	1980:1980	506+0	64.8 : 0.0%
3/1+3/2	Unnamed Road Right Left	U	N/A	N/A	E	F	1	57:41	16	731	1764:1805	484+533	71.9 : 71.9%
4/1		U	N/A	N/A	-		-	-	-	1005	Inf	Inf	0.0%
5/1		U	N/A	N/A	-		-	-	-	176	Inf	Inf	0.0%
6/1		U	N/A	N/A	-		-	-	-	676	Inf	Inf	0.0%
Item	Arriving (pcu)	Leaving (pcu)	Turners In Gaps (pcu)	Turners When Unopposed (pcu)	Turners In Intergreen (pcu)	Uniform Delay (pcuHr)	Rand + Oversat Delay (pcuHr)	Storage Area Uniform Delay (pcuHr)	Total Delay (pcuHr)	Av. Delay Per PCU (s/pcu)	Max. Back of Uniform Queue (pcu)	Rand + Oversat Queue (pcu)	Mean Max Queue (pcu)
Network: B430/Unnamed Road Signalisation	-	-	0	0	0	10.6	3.3	0.0	13.9	-	-	-	-
B430/Unnamed Road	-	-	0	0	0	10.6	3.3	0.0	13.9	-	-	-	-
1/1+1/2	798	798	-	-	-	5.3	1.2	-	6.4	29.1	12.4	1.2	13.6
2/2+2/1	328	328	-	-	-	2.7	0.9	-	3.6	39.9	7.3	0.9	8.2
3/1+3/2	731	731	-	-	-	2.6	1.3	-	3.8	18.8	8.9	1.3	10.1
4/1	1005	1005	-	-	-	0.0	0.0	-	0.0	0.0	0.0	0.0	0.0
5/1	176	176	-	-	-	0.0	0.0	-	0.0	0.0	0.0	0.0	0.0
6/1	676	676	-	-	-	0.0	0.0	-	0.0	0.0	0.0	0.0	0.0

C1	PRC for Signalled Lanes (%):	25.1	Total Delay for Signalled Lanes (pcuHr):	13.90	Cycle Time (s):	90
	PRC Over All Lanes (%):	25.1	Total Delay Over All Lanes(pcuHr):	13.90		

Scenario 3: '2031 Ref Case + Development AM' (FG3: '2031 Reference Case + Development AM', Plan 1: 'Network Control Plan 1')

Stage Sequence Diagram

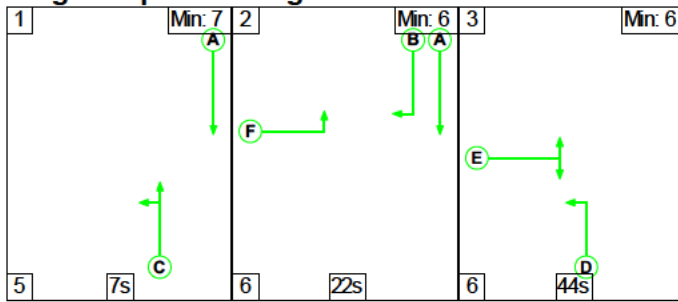

Stage Timings

Stage	1	2	3
Duration	7	22	44
Change Point	0	12	40

Signal Timings Diagram

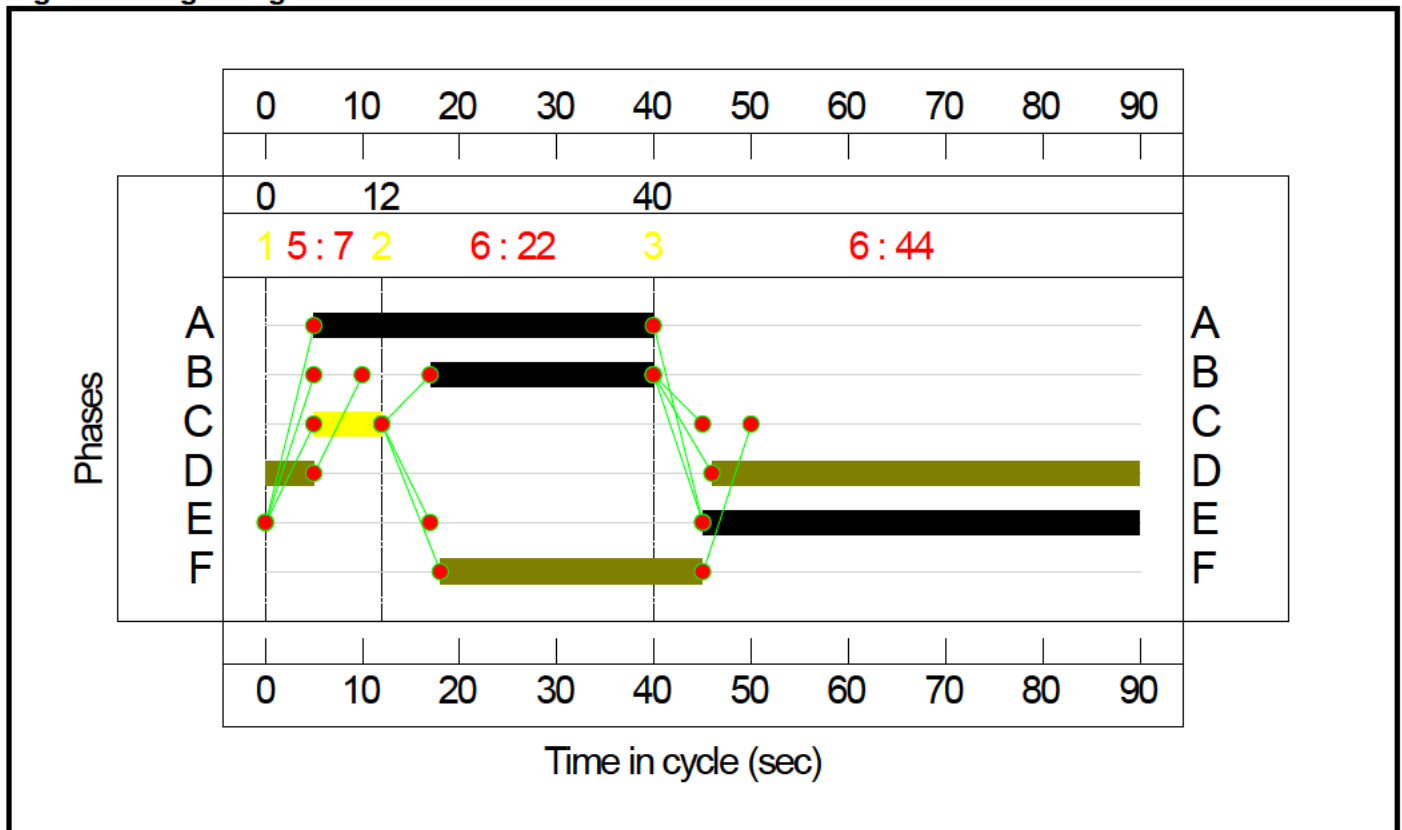

Network Layout Diagram

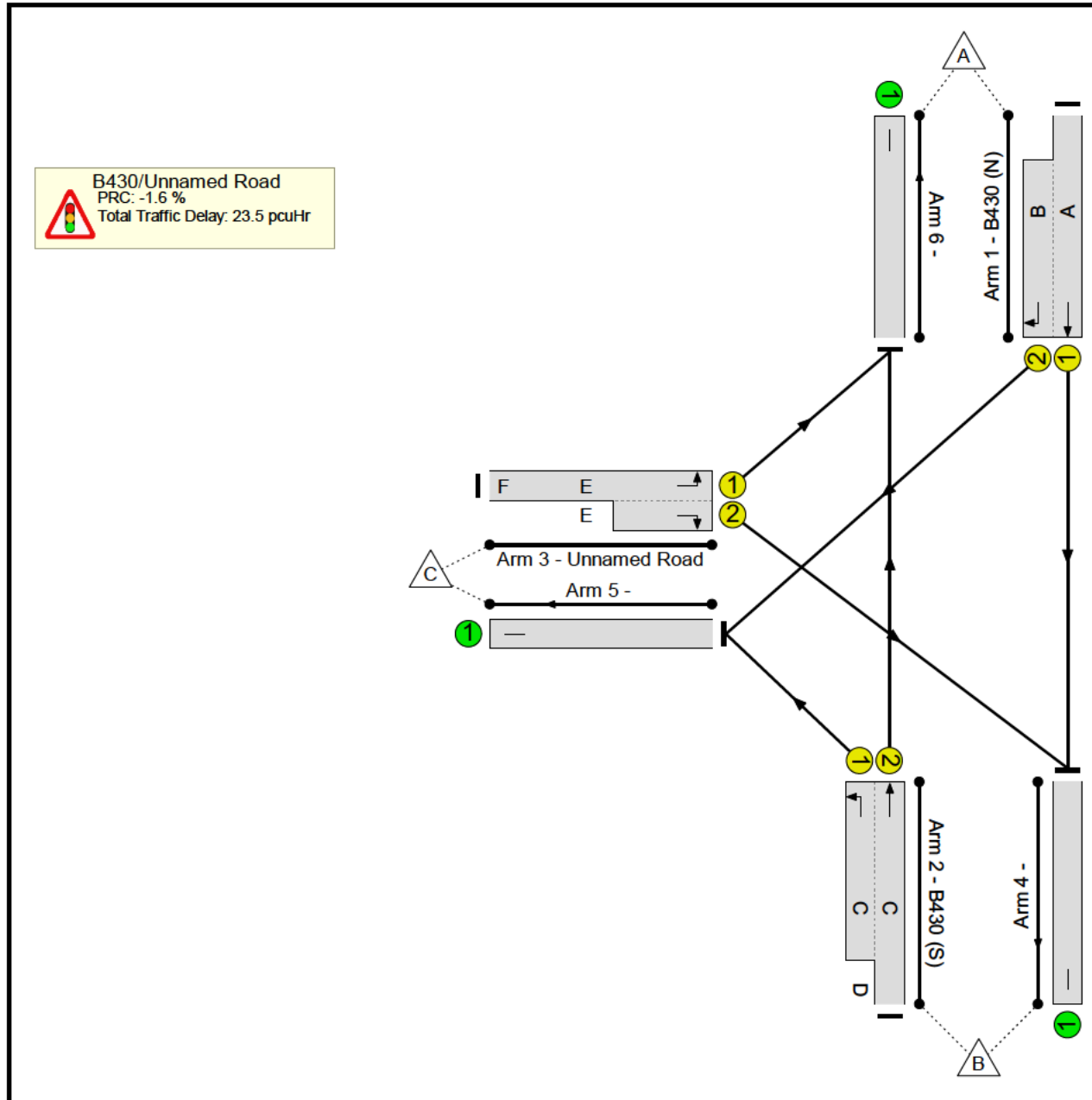

Network Results

Item	Lane Description	Lane Type	Controller Stream	Position In Filtered Route	Full Phase	Arrow Phase	Num Greens	Total Green (s)	Arrow Green (s)	Demand Flow (pcu)	Sat Flow (pcu/Hr)	Capacity (pcu)	Deg Sat (%)
Network: B430/Unnamed Road Signalisation	-	-	N/A	-	-		-	-	-	-	-	-	91.4%
B430/Unnamed Road	-	-	N/A	-	-		-	-	-	-	-	-	91.4%
1/1+1/2	B430 (N) Ahead Right	U	N/A	N/A	A B		1	35:23	-	1149	1980:1800	792+480	91.4 : 88.5%
2/2+2/1	B430 (S) Left Ahead	U	N/A	N/A	C	D	1	7:56	49	124	1980:1980	176+0	70.5 : 0.0%
3/1+3/2	Unnamed Road Right Left	U	N/A	N/A	E	F	1	72:45	27	944	1764:1805	420+629	90.0 : 90.0%
4/1		U	N/A	N/A	-		-	-	-	1290	Inf	Inf	0.0%
5/1		U	N/A	N/A	-		-	-	-	425	Inf	Inf	0.0%
6/1		U	N/A	N/A	-		-	-	-	502	Inf	Inf	0.0%
Item	Arriving (pcu)	Leaving (pcu)	Turners In Gaps (pcu)	Turners When Unopposed (pcu)	Turners In Intergreen (pcu)	Uniform Delay (pcuHr)	Rand + Oversat Delay (pcuHr)	Storage Area Uniform Delay (pcuHr)	Total Delay (pcuHr)	Av. Delay Per PCU (s/pcu)	Max. Back of Uniform Queue (pcu)	Rand + Oversat Queue (pcu)	Mean Max Queue (pcu)
Network: B430/Unnamed Road Signalisation	-	-	0	0	0	13.8	9.7	0.0	23.5	-	-	-	-
B430/Unnamed Road	-	-	0	0	0	13.8	9.7	0.0	23.5	-	-	-	-
1/1+1/2	1149	1149	-	-	-	8.9	4.4	-	13.2	41.5	17.1	4.4	21.5
2/2+2/1	124	124	-	-	-	1.4	1.1	-	2.5	73.0	3.0	1.1	4.1
3/1+3/2	944	944	-	-	-	3.6	4.2	-	7.7	29.5	17.3	4.2	21.5
4/1	1290	1290	-	-	-	0.0	0.0	-	0.0	0.0	0.0	0.0	0.0
5/1	425	425	-	-	-	0.0	0.0	-	0.0	0.0	0.0	0.0	0.0
6/1	502	502	-	-	-	0.0	0.0	-	0.0	0.0	0.0	0.0	0.0

C1	PRC for Signalled Lanes (%):	-1.6	Total Delay for Signalled Lanes (pcuHr):	23.50	Cycle Time (s):	90
	PRC Over All Lanes (%):	-1.6	Total Delay Over All Lanes(pcuHr):	23.50		

Scenario 4: '2031 Ref Case + Development PM' (FG4: '2031 Reference Case + Development PM', Plan 1: 'Network Control Plan 1')

Stage Sequence Diagram

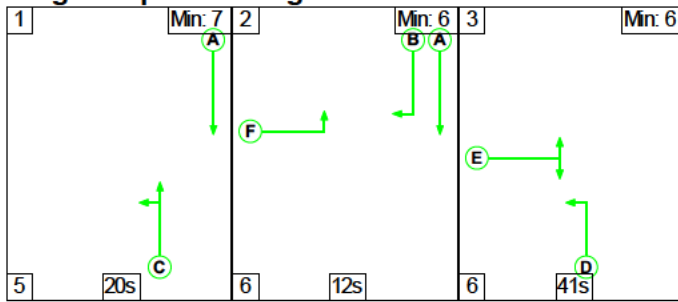

Stage Timings

Stage	1	2	3
Duration	20	12	41
Change Point	0	25	43

Signal Timings Diagram

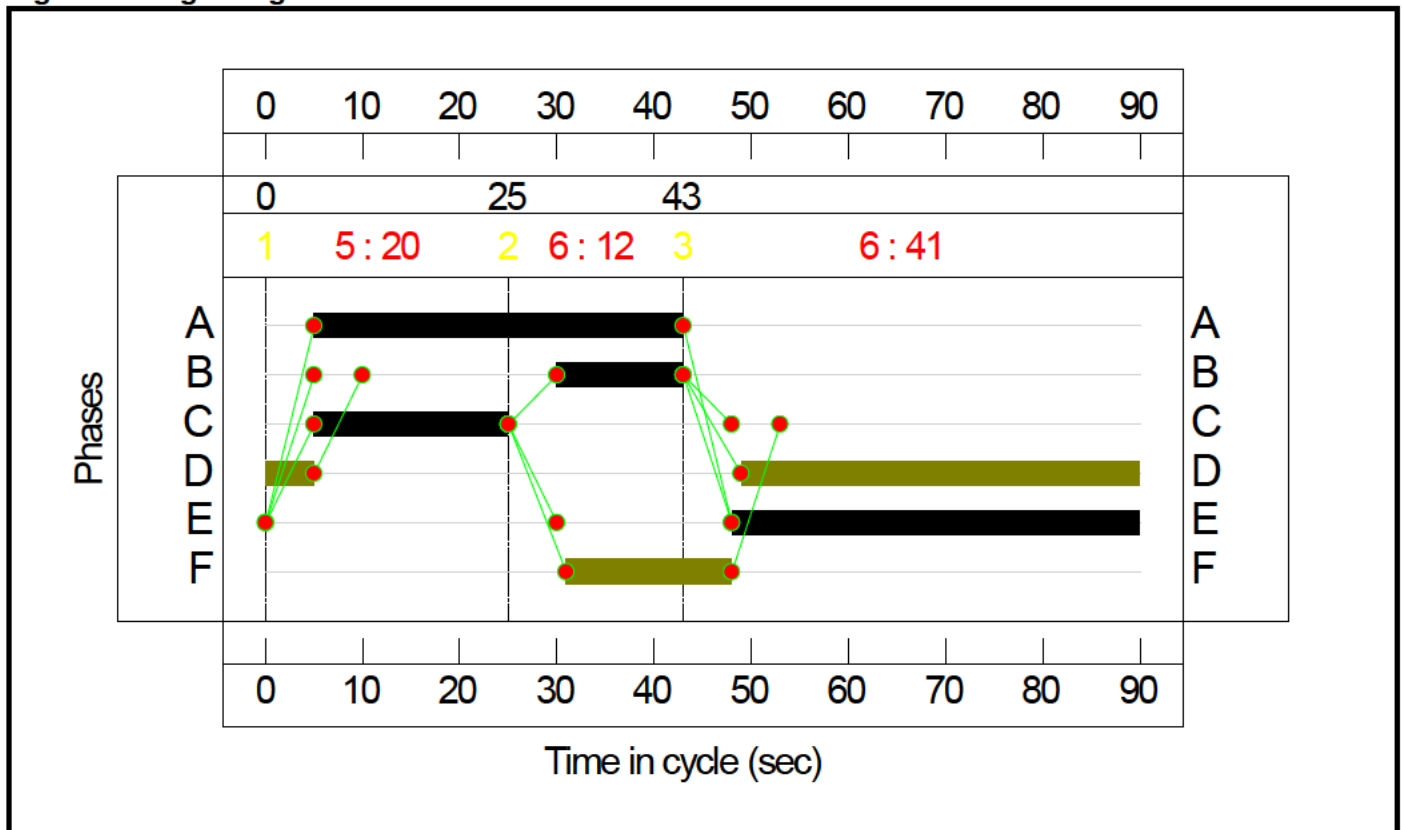

Network Layout Diagram

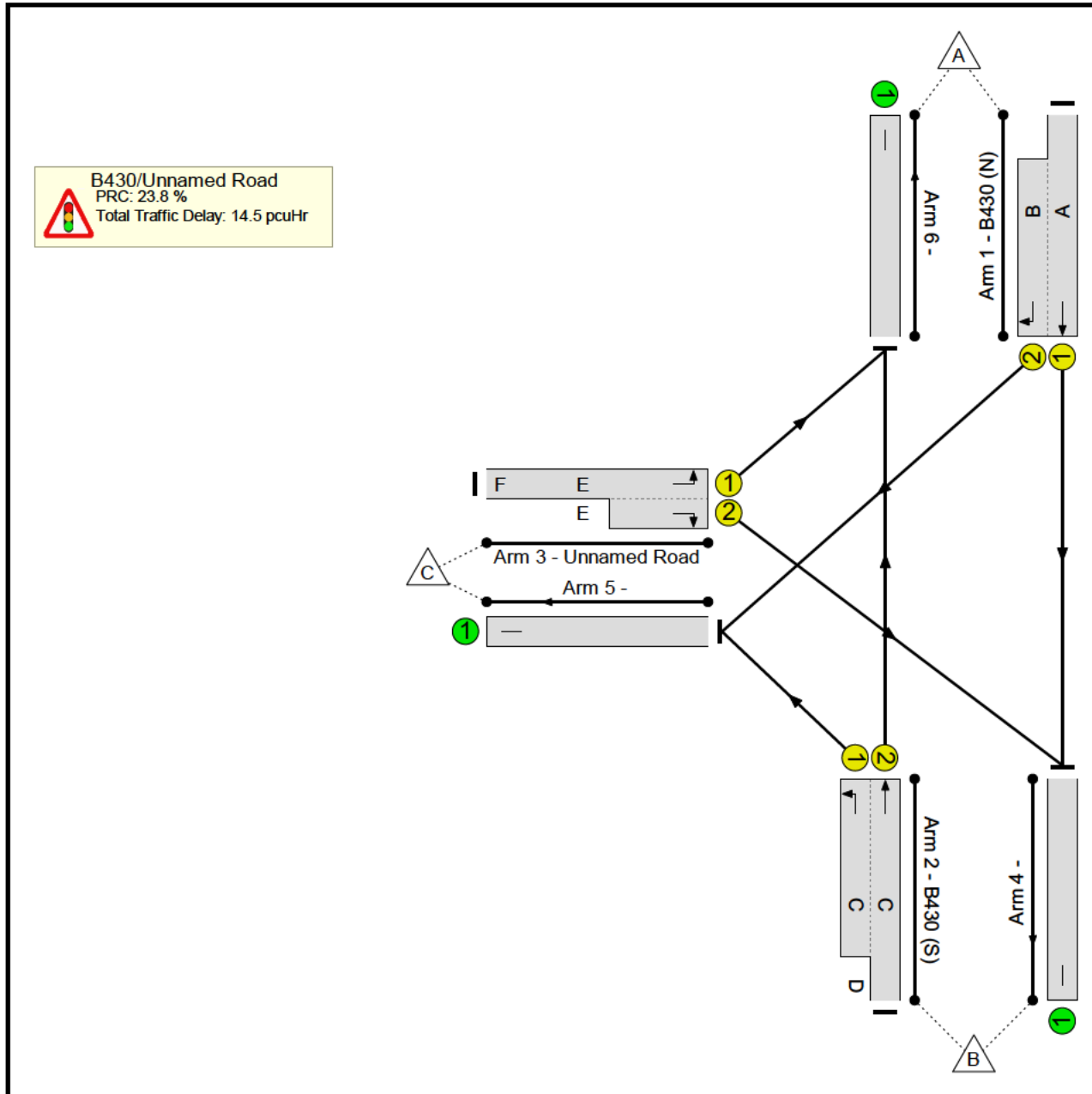

Network Results

Item	Lane Description	Lane Type	Controller Stream	Position In Filtered Route	Full Phase	Arrow Phase	Num Greens	Total Green (s)	Arrow Green (s)	Demand Flow (pcu)	Sat Flow (pcu/Hr)	Capacity (pcu)	Deg Sat (%)
Network: B430/Unamed Road Signalisation	-	-	N/A	-	-		-	-	-	-	-	-	72.7%
B430/Unamed Road	-	-	N/A	-	-		-	-	-	-	-	-	72.7%
1/1+1/2	B430 (N) Ahead Right	U	N/A	N/A	A B		1	38:13	-	809	1980:1800	858+280	71.3 : 70.4%
2/2+2/1	B430 (S) Left Ahead	U	N/A	N/A	C	D	1	20:66	46	319	1980:1980	462+0	69.0 : 0.0%
3/1+3/2	Unamed Road Right Left	U	N/A	N/A	E	F	1	59:42	17	752	1764:1805	490+545	72.7 : 72.7%
4/1		U	N/A	N/A	-		-	-	-	1008	Inf	Inf	0.0%
5/1		U	N/A	N/A	-		-	-	-	197	Inf	Inf	0.0%
6/1		U	N/A	N/A	-		-	-	-	675	Inf	Inf	0.0%
Item	Arriving (pcu)	Leaving (pcu)	Turners In Gaps (pcu)	Turners When Unopposed (pcu)	Turners In Intergreen (pcu)	Uniform Delay (pcuHr)	Rand + Oversat Delay (pcuHr)	Storage Area Uniform Delay (pcuHr)	Total Delay (pcuHr)	Av. Delay Per PCU (s/pcu)	Max. Back of Uniform Queue (pcu)	Rand + Oversat Queue (pcu)	Mean Max Queue (pcu)
Network: B430/Unamed Road Signalisation	-	-	0	0	0	10.8	3.6	0.0	14.5	-	-	-	-
B430/Unamed Road	-	-	0	0	0	10.8	3.6	0.0	14.5	-	-	-	-
1/1+1/2	809	809	-	-	-	5.5	1.2	-	6.7	30.0	12.4	1.2	13.6
2/2+2/1	319	319	-	-	-	2.8	1.1	-	3.9	43.9	7.3	1.1	8.4
3/1+3/2	752	752	-	-	-	2.5	1.3	-	3.8	18.3	9.2	1.3	10.5
4/1	1008	1008	-	-	-	0.0	0.0	-	0.0	0.0	0.0	0.0	0.0
5/1	197	197	-	-	-	0.0	0.0	-	0.0	0.0	0.0	0.0	0.0
6/1	675	675	-	-	-	0.0	0.0	-	0.0	0.0	0.0	0.0	0.0

C1	PRC for Signalled Lanes (%):	23.8	Total Delay for Signalled Lanes (pcuHr):	14.47	Cycle Time (s):	90
	PRC Over All Lanes (%):	23.8	Total Delay Over All Lanes(pcuHr):	14.47		

T19562
Heyford Park



Appendix H

LinSig Output – B430/B4030 Middleton Stoney

Full Input Data And Results

User and Project Details

Project:	Heyford Park
Title:	B430/B4030
Location:	
Client:	Richborough Estates
Site Ref(s):	T19562
Date Started:	25/11/2016
Additional detail:	
File name:	T19562 - B430-B4030.lsg3x
Author:	Max Law
Company:	Hub Transport Planning Ltd
Address:	Radclyffe House, 66/68 Hagley Road, Edgbaston, Birmingham, West Midlands, B16 8PF

Network Layout Diagram

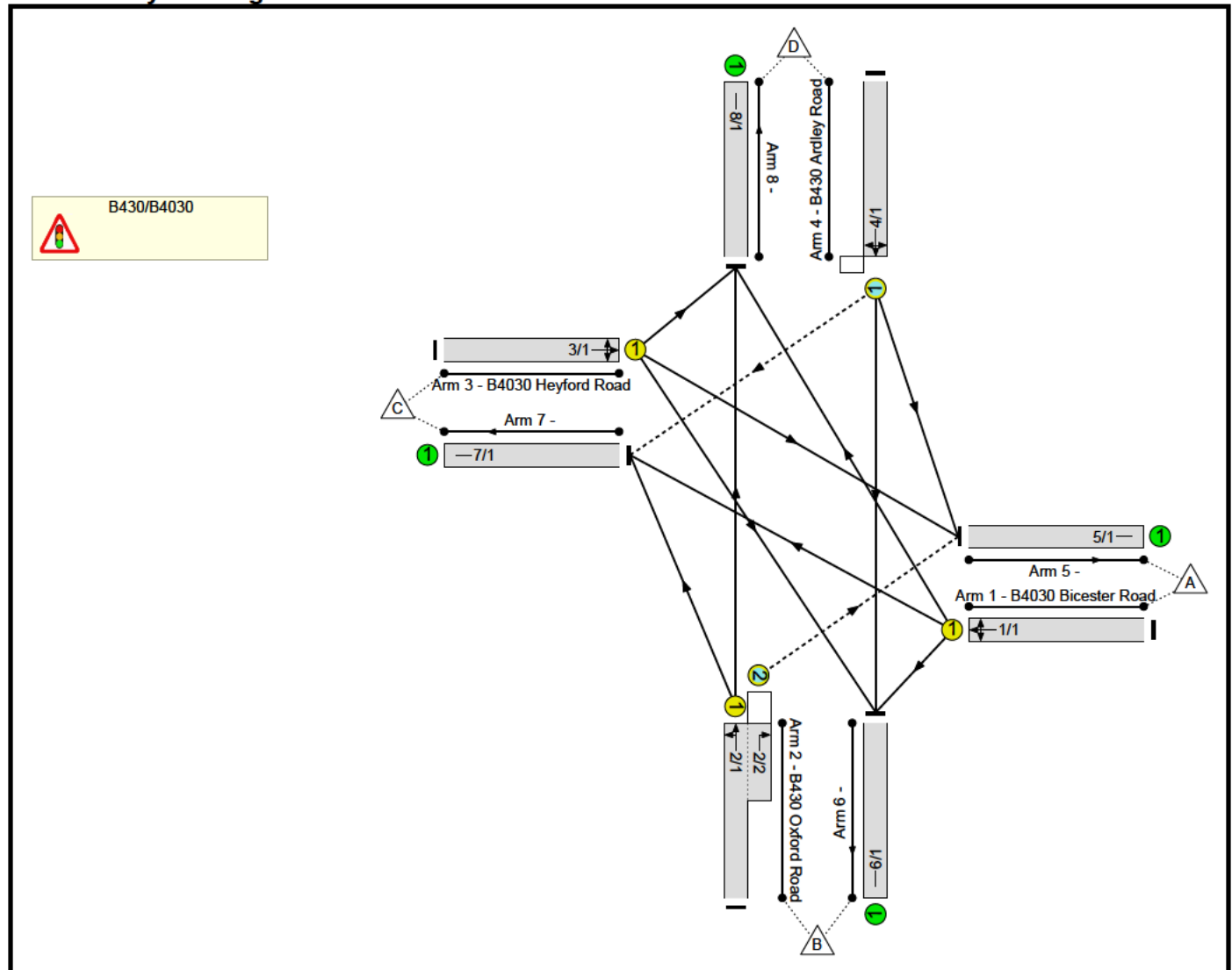

Phase Diagram

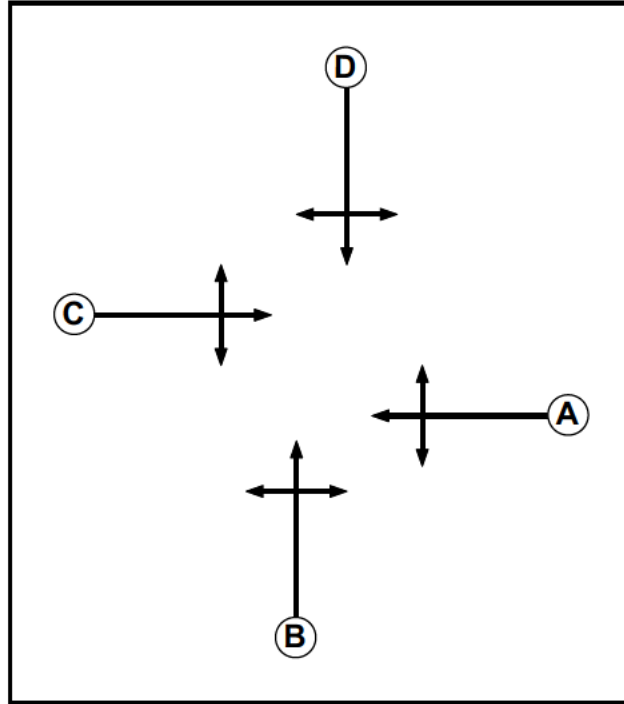

Phase Input Data

Phase Name	Phase Type	Assoc. Phase	Street Min	Cont Min
A	Traffic		7	7
B	Traffic		7	7
C	Traffic		7	7
D	Traffic		7	7

Phase Intergreens Matrix

		Starting Phase				
		A	B	C	D	
Terminating Phase	A	5	8	7		
	B	5	8	-		
	C	8	7	5		
	D	8	-	5		

Phases in Stage

Stage No.	Phases in Stage
1	B D
2	A
3	C

Stage Diagram

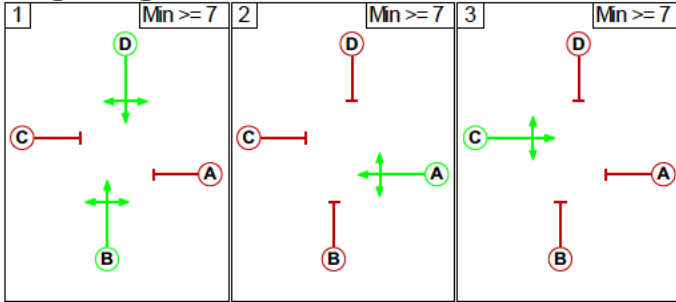

Phase Delays

Term. Stage	Start Stage	Phase	Type	Value	Cont value
There are no Phase Delays defined					

Prohibited Stage Change

		To Stage		
		1	2	3
From Stage	1		8	8
	2	7		8
	3	7	8	

Give-Way Lane Input Data

Junction: B430/B4030											
Lane	Movement	Max Flow when Giving Way (PCU/Hr)	Min Flow when Giving Way (PCU/Hr)	Opposing Lane	Opp. Lane Coeff.	Opp. Mvmnts.	Right Turn Storage (PCU)	Non-Blocking Storage (PCU)	RTF	Right Turn Move up (s)	Max Turns in Intergreen (PCU)
2/2 (B430 Oxford Road)	5/1 (Right)	1439	0	4/1	1.09	To 5/1 (Left) To 6/1 (Ahead)	2.00	-	0.50	2	2.00
4/1 (B430 Ardley Road)	7/1 (Right)	1439	0	2/1	1.09	To 7/1 (Left) To 8/1 (Ahead)	1.00	1.00	0.50	2	1.00

Lane Input Data

Junction: B430/B4030												
Lane	Lane Type	Phases	Start Disp.	End Disp.	Physical Length (PCU)	Sat Flow Type	Def User Saturation Flow (PCU/Hr)	Lane Width (m)	Gradient	Nearside Lane	Turns	Turning Radius (m)
1/1 (B4030 Bicester Road)	U	A	2	3	60.0	Geom	-	3.00	0.00	Y	Arm 6 Left	13.00
											Arm 7 Ahead	30.00
											Arm 8 Right	30.00
2/1 (B430 Oxford Road)	U	B	2	3	60.0	Geom	-	3.00	0.00	Y	Arm 7 Left	30.00
											Arm 8 Ahead	Inf
2/2 (B430 Oxford Road)	O	B	2	3	5.0	Geom	-	3.00	0.00	N	Arm 5 Right	10.00
3/1 (B4030 Heyford Road)	U	C	2	3	60.0	Geom	-	3.00	0.00	Y	Arm 5 Ahead	30.00
											Arm 6 Right	30.00
											Arm 8 Left	7.00
4/1 (B430 Ardley Road)	O	D	2	3	60.0	Geom	-	3.30	0.00	Y	Arm 5 Left	12.00
											Arm 6 Ahead	Inf
											Arm 7 Right	8.00
5/1	U		2	3	60.0	Inf	-	-	-	-	-	-
6/1	U		2	3	60.0	Inf	-	-	-	-	-	-
7/1	U		2	3	60.0	Inf	-	-	-	-	-	-
8/1	U		2	3	60.0	Inf	-	-	-	-	-	-

Traffic Flow Groups

Flow Group	Start Time	End Time	Duration	Formula
1: '2031 Reference Case AM'	08:00	09:00	01:00	
2: '2031 Reference Case PM'	17:00	18:00	01:00	
3: '2031 Reference Case + Development AM'	08:00	09:00	01:00	
4: '2031 Reference Case + Development PM'	17:00	18:00	01:00	

Scenario 1: '2031 Reference Case AM' (FG1: '2031 Reference Case AM', Plan 1: 'Network Control Plan 1')**Traffic Flows, Desired****Desired Flow :**

	Destination					
		A	B	C	D	Tot.
Origin	A	0	137	437	32	606
	B	63	0	181	95	339
	C	31	6	0	0	37
	D	608	657	13	0	1278
	Tot.	702	800	631	127	2260

Traffic Lane Flows

Lane	Scenario 1: 2031 Reference Case AM
Junction: B430/B4030	
1/1	606
2/1 (with short)	339(In) 276(Out)
2/2 (short)	63
3/1	37
4/1	1278
5/1	702
6/1	800
7/1	631
8/1	127

Lane Saturation Flows

Junction: B430/B4030								
Lane	Lane Width (m)	Gradient	Nearside Lane	Allowed Turns	Turning Radius (m)	Turning Prop.	Sat Flow (PCU/Hr)	Flared Sat Flow (PCU/Hr)
1/1 (B4030 Bicester Road)	3.00	0.00	Y	Arm 6 Left	13.00	22.6 %	1798	1798
				Arm 7 Ahead	30.00	72.1 %		
				Arm 8 Right	30.00	5.3 %		
2/1 (B430 Oxford Road)	3.00	0.00	Y	Arm 7 Left	30.00	65.6 %	1854	1854
				Arm 8 Ahead	Inf	34.4 %		
2/2 (B430 Oxford Road)	3.00	0.00	N	Arm 5 Right	10.00	100.0 %	1787	1787
3/1 (B4030 Heyford Road)	3.00	0.00	Y	Arm 5 Ahead	30.00	83.8 %	1824	1824
				Arm 6 Right	30.00	16.2 %		
				Arm 8 Left	7.00	0.0 %		
4/1 (B430 Ardley Road)	3.30	0.00	Y	Arm 5 Left	12.00	47.6 %	1833	1833
				Arm 6 Ahead	Inf	51.4 %		
				Arm 7 Right	8.00	1.0 %		
5/1	Infinite Saturation Flow						Inf	Inf
6/1	Infinite Saturation Flow						Inf	Inf
7/1	Infinite Saturation Flow						Inf	Inf
8/1	Infinite Saturation Flow						Inf	Inf

Scenario 2: '2031 Reference Case PM' (FG2: '2031 Reference Case PM', Plan 1: 'Network Control Plan 1')
Traffic Flows, Desired

Desired Flow :

	Origin	Destination				Tot.
		A	B	C	D	
	A	0	35	560	7	602
	B	235	0	91	321	647
	C	38	0	0	0	38
	D	390	605	10	0	1005
	Tot.	663	640	661	328	2292

Traffic Lane Flows

Lane	Scenario 2: 2031 Reference Case PM
Junction: B430/B4030	
1/1	602
2/1 (with short)	647(In) 412(Out)
2/2 (short)	235
3/1	38
4/1	1005
5/1	663
6/1	640
7/1	661
8/1	328

Lane Saturation Flows

Junction: B430/B4030								
Lane	Lane Width (m)	Gradient	Nearside Lane	Allowed Turns	Turning Radius (m)	Turning Prop.	Sat Flow (PCU/Hr)	Flared Sat Flow (PCU/Hr)
1/1 (B4030 Bicester Road)	3.00	0.00	Y	Arm 6 Left	13.00	5.8 %	1817	1817
				Arm 7 Ahead	30.00	93.0 %		
				Arm 8 Right	30.00	1.2 %		
2/1 (B430 Oxford Road)	3.00	0.00	Y	Arm 7 Left	30.00	22.1 %	1894	1894
				Arm 8 Ahead	Inf	77.9 %		
2/2 (B430 Oxford Road)	3.00	0.00	N	Arm 5 Right	10.00	100.0 %	1787	1787
3/1 (B4030 Heyford Road)	3.00	0.00	Y	Arm 5 Ahead	30.00	100.0 %	1824	1824
				Arm 6 Right	30.00	0.0 %		
				Arm 8 Left	7.00	0.0 %		
4/1 (B430 Ardley Road)	3.30	0.00	Y	Arm 5 Left	12.00	38.8 %	1852	1852
				Arm 6 Ahead	Inf	60.2 %		
				Arm 7 Right	8.00	1.0 %		
5/1				Infinite Saturation Flow			Inf	Inf
6/1				Infinite Saturation Flow			Inf	Inf
7/1				Infinite Saturation Flow			Inf	Inf
8/1				Infinite Saturation Flow			Inf	Inf

Scenario 3: '2031 Reference Case + Development AM' (FG3: '2031 Reference Case + Development AM', Plan 1: 'Network Control Plan 1')

Traffic Flows, Desired

Desired Flow :

	Destination					
		A	B	C	D	Tot.
Origin	A	0	131	437	30	598
	B	63	0	191	92	346
	C	31	6	0	0	37
	D	628	655	13	0	1296
	Tot.	722	792	641	122	2277

Traffic Lane Flows

Lane	Scenario 3: 2031 Reference Case + Development AM
Junction: B430/B4030	
1/1	598
2/1 (with short)	346(In) 283(Out)
2/2 (short)	63
3/1	37
4/1	1296
5/1	722
6/1	792
7/1	641
8/1	122

Lane Saturation Flows

Junction: B430/B4030								
Lane	Lane Width (m)	Gradient	Nearside Lane	Allowed Turns	Turning Radius (m)	Turning Prop.	Sat Flow (PCU/Hr)	Flared Sat Flow (PCU/Hr)
1/1 (B4030 Bicester Road)	3.00	0.00	Y	Arm 6 Left	13.00	21.9 %	1799	1799
				Arm 7 Ahead	30.00	73.1 %		
				Arm 8 Right	30.00	5.0 %		
2/1 (B430 Oxford Road)	3.00	0.00	Y	Arm 7 Left	30.00	67.5 %	1852	1852
				Arm 8 Ahead	Inf	32.5 %		
2/2 (B430 Oxford Road)	3.00	0.00	N	Arm 5 Right	10.00	100.0 %	1787	1787
3/1 (B4030 Heyford Road)	3.00	0.00	Y	Arm 5 Ahead	30.00	83.8 %	1824	1824
				Arm 6 Right	30.00	16.2 %		
				Arm 8 Left	7.00	0.0 %		
4/1 (B430 Ardley Road)	3.30	0.00	Y	Arm 5 Left	12.00	48.5 %	1831	1831
				Arm 6 Ahead	Inf	50.5 %		
				Arm 7 Right	8.00	1.0 %		
5/1	Infinite Saturation Flow						Inf	Inf
6/1	Infinite Saturation Flow						Inf	Inf
7/1	Infinite Saturation Flow						Inf	Inf
8/1	Infinite Saturation Flow						Inf	Inf

Scenario 4: '2031 Reference Case + Development PM' (FG4: '2031 Reference Case + Development PM', Plan 1: 'Network Control Plan 1')

Traffic Flows, Desired

Desired Flow :

	Destination					Tot.
	A	B	C	D		
Origin	A	0	39	554	4	597
	B	230	0	121	313	664
	C	38	0	0	0	38
	D	402	596	10	0	1008
	Tot.	670	635	685	317	2307

Traffic Lane Flows

Lane	Scenario 4: 2031 Reference Case + Development PM
Junction: B430/B4030	
1/1	597
2/1 (with short)	664(In) 434(Out)
2/2 (short)	230
3/1	38
4/1	1008
5/1	670
6/1	635
7/1	685
8/1	317

Lane Saturation Flows

Junction: B430/B4030								
Lane	Lane Width (m)	Gradient	Nearside Lane	Allowed Turns	Turning Radius (m)	Turning Prop.	Sat Flow (PCU/Hr)	Flared Sat Flow (PCU/Hr)
1/1 (B4030 Bicester Road)	3.00	0.00	Y	Arm 6 Left	13.00	6.5 %	1816	1816
				Arm 7 Ahead	30.00	92.8 %		
				Arm 8 Right	30.00	0.7 %		
2/1 (B430 Oxford Road)	3.00	0.00	Y	Arm 7 Left	30.00	27.9 %	1889	1889
				Arm 8 Ahead	Inf	72.1 %		
2/2 (B430 Oxford Road)	3.00	0.00	N	Arm 5 Right	10.00	100.0 %	1787	1787
3/1 (B4030 Heyford Road)	3.00	0.00	Y	Arm 5 Ahead	30.00	100.0 %	1824	1824
				Arm 6 Right	30.00	0.0 %		
				Arm 8 Left	7.00	0.0 %		
4/1 (B430 Ardley Road)	3.30	0.00	Y	Arm 5 Left	12.00	39.9 %	1849	1849
				Arm 6 Ahead	Inf	59.1 %		
				Arm 7 Right	8.00	1.0 %		
5/1				Infinite Saturation Flow			Inf	Inf
6/1				Infinite Saturation Flow			Inf	Inf
7/1				Infinite Saturation Flow			Inf	Inf
8/1				Infinite Saturation Flow			Inf	Inf

Scenario 1: '2031 Reference Case AM' (FG1: '2031 Reference Case AM', Plan 1: 'Network Control Plan 1')
Stage Sequence Diagram

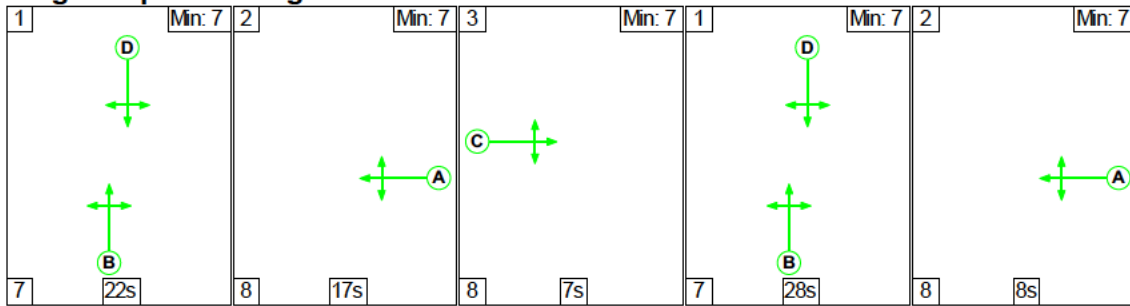

Stage Timings

Stage	1	2	3	1	2
Duration	22	17	7	28	8
Change Point	0	29	54	69	104

Signal Timings Diagram

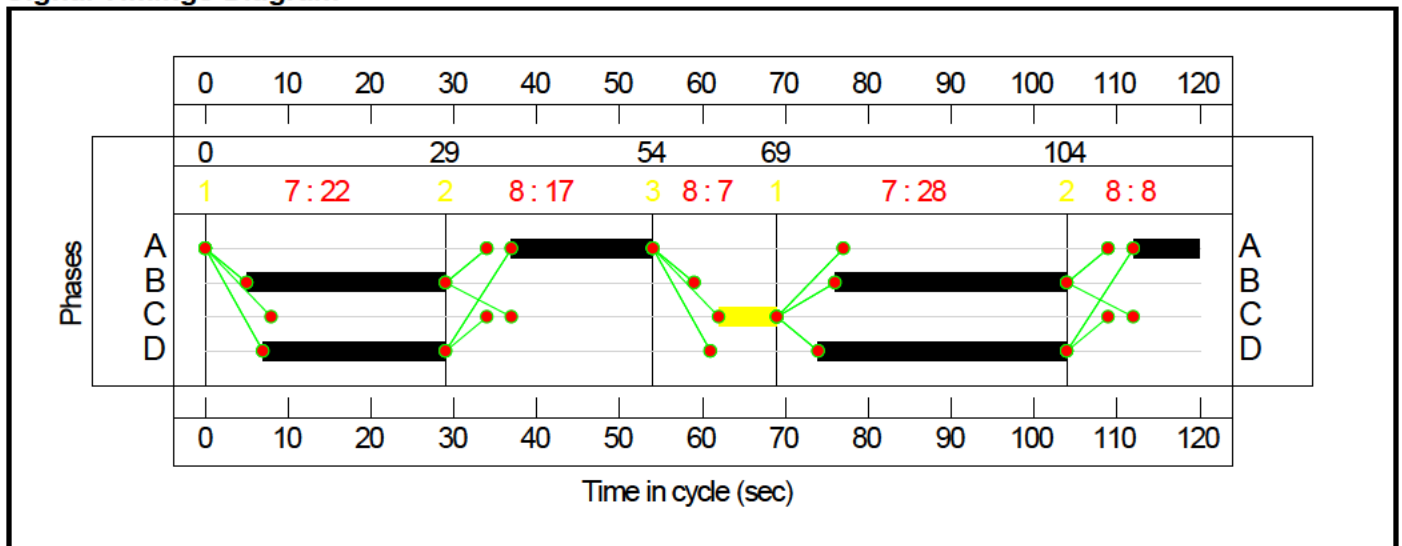

Network Layout Diagram

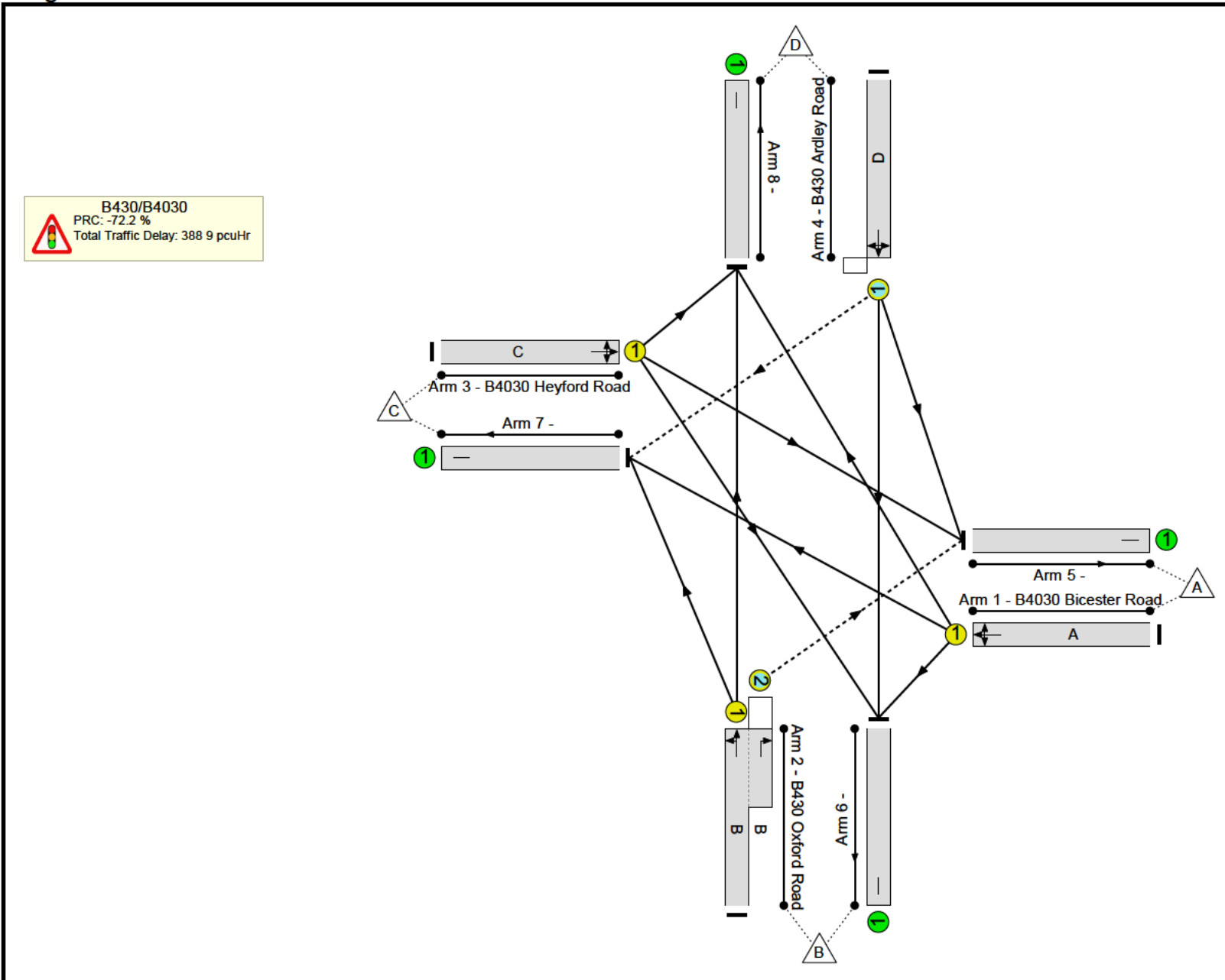

Network Results

Item	Lane Description	Lane Type	Controller Stream	Position In Filtered Route	Full Phase	Arrow Phase	Num Greens	Total Green (s)	Arrow Green (s)	Demand Flow (pcu)	Sat Flow (pcu/Hr)	Capacity (pcu)	Deg Sat (%)
Network: B430/B4030	-	-	N/A	-	-		-	-	-	-	-	-	154.9%
B430/B4030	-	-	N/A	-	-		-	-	-	-	-	-	154.9%
1/1	B4030 Bicester Road Left Ahead Right	U	N/A	N/A	A		2	25	-	606	1798	405	149.8%
2/1+2/2	B430 Oxford Road Right Left Ahead	U+O	N/A	N/A	B		2	52	-	339	1854:1787	725+120	38.1 : 52.5%
3/1	B4030 Heyford Road Ahead Right Left	U	N/A	N/A	C		1	7	-	37	1824	122	30.4%
4/1	B430 Ardley Road Left Ahead Right	O	N/A	N/A	D		2	52	-	1278	1833	825	154.9%
5/1		U	N/A	N/A	-		-	-	-	702	Inf	Inf	0.0%
6/1		U	N/A	N/A	-		-	-	-	800	Inf	Inf	0.0%
7/1		U	N/A	N/A	-		-	-	-	631	Inf	Inf	0.0%
8/1		U	N/A	N/A	-		-	-	-	127	Inf	Inf	0.0%

Item	Arriving (pcu)	Leaving (pcu)	Turners In Gaps (pcu)	Turners When Unopposed (pcu)	Turners In Intergreen (pcu)	Uniform Delay (pcuHr)	Rand + Oversat Delay (pcuHr)	Storage Area Uniform Delay (pcuHr)	Total Delay (pcuHr)	Av. Delay Per PCU (s/pcu)	Max. Back of Uniform Queue (pcu)	Rand + Oversat Queue (pcu)	Mean Max Queue (pcu)
Network: B430/B4030	-	-	8	0	63	57.8	330.7	0.4	388.9	-	-	-	-
B430/B4030	-	-	8	0	63	57.8	330.7	0.4	388.9	-	-	-	-
1/1	606	405	-	-	-	17.6	102.2	-	119.8	711.7	24.1	102.2	126.3
2/1+2/2	339	339	0	0	63	1.1	0.3	0.4	1.9	19.7	4.1	0.3	4.5
3/1	37	37	-	-	-	0.5	0.2	-	0.8	74.6	1.2	0.2	1.4
4/1	1278	825	8	0	0	38.5	228.0	0.0	266.4	750.5	56.8	228.0	284.8
5/1	486	486	-	-	-	0.0	0.0	-	0.0	0.0	0.0	0.0	0.0
6/1	522	522	-	-	-	0.0	0.0	-	0.0	0.0	0.0	0.0	0.0
7/1	481	481	-	-	-	0.0	0.0	-	0.0	0.0	0.0	0.0	0.0
8/1	116	116	-	-	-	0.0	0.0	-	0.0	0.0	0.0	0.0	0.0
C1			PRC for Signalled Lanes (%):		-72.2	Total Delay for Signalled Lanes (pcuHr):		388.88	Cycle Time (s): 120				
			PRC Over All Lanes (%):		-72.2	Total Delay Over All Lanes(pcuHr):		388.88					

Scenario 2: '2031 Reference Case PM' (FG2: '2031 Reference Case PM', Plan 1: 'Network Control Plan 1')

Stage Sequence Diagram

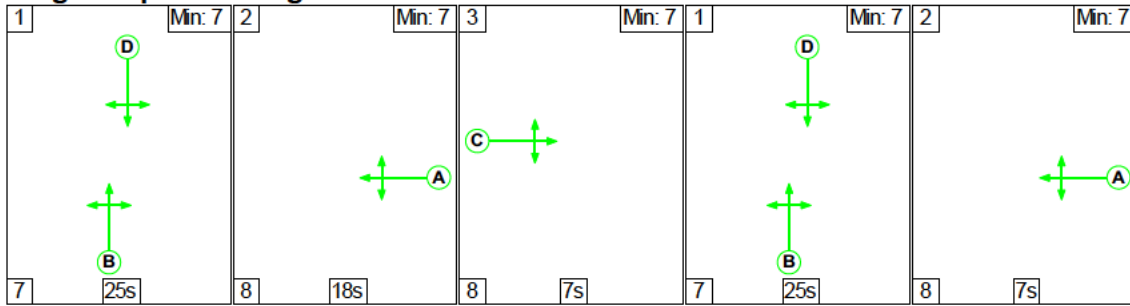

Stage Timings

Stage	1	2	3	1	2
Duration	25	18	7	25	7
Change Point	0	32	58	73	105

Signal Timings Diagram

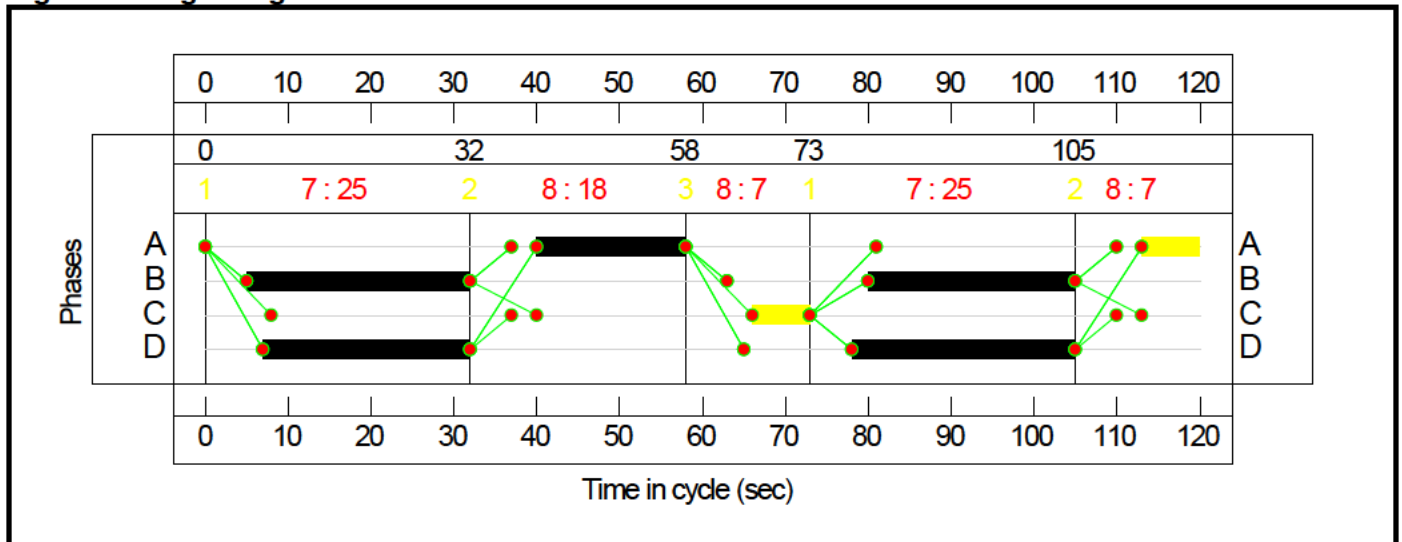

Network Layout Diagram

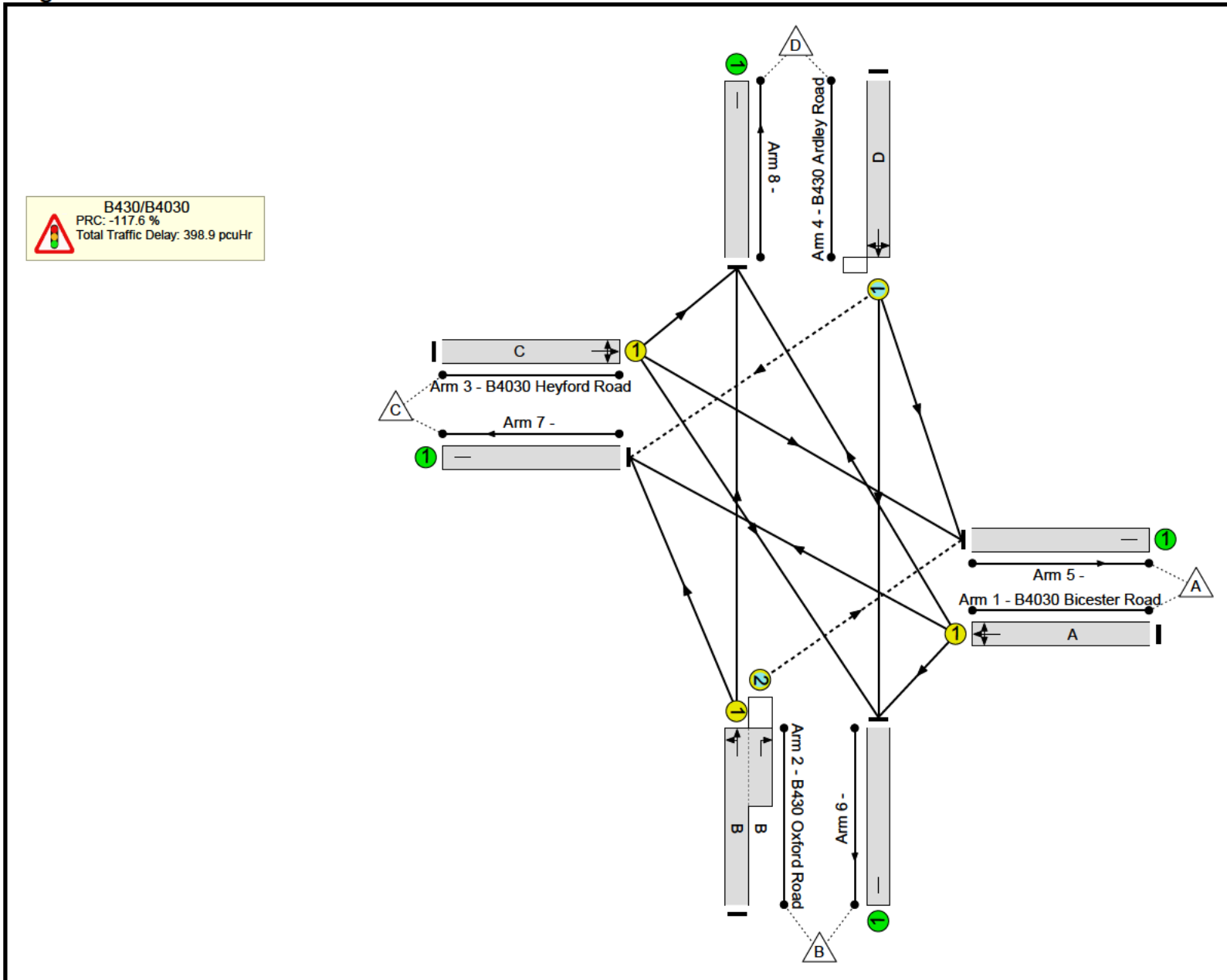

Network Results

Item	Lane Description	Lane Type	Controller Stream	Position In Filtered Route	Full Phase	Arrow Phase	Num Greens	Total Green (s)	Arrow Green (s)	Demand Flow (pcu)	Sat Flow (pcu/Hr)	Capacity (pcu)	Deg Sat (%)
Network: B430/B4030	-	-	N/A	-	-		-	-	-	-	-	-	195.8%
B430/B4030	-	-	N/A	-	-		-	-	-	-	-	-	195.8%
1/1	B4030 Bicester Road Left Ahead Right	U	N/A	N/A	A		2	25	-	602	1817	409	147.3%
2/1+2/2	B430 Oxford Road Right Left Ahead	U+O	N/A	N/A	B		2	52	-	647	1894:1787	210+120	195.8 : 195.8%
3/1	B4030 Heyford Road Ahead Right Left	U	N/A	N/A	C		1	7	-	38	1824	122	31.3%
4/1	B430 Ardley Road Left Ahead Right	O	N/A	N/A	D		2	52	-	1005	1852	833	120.6%
5/1		U	N/A	N/A	-		-	-	-	663	Inf	Inf	0.0%
6/1		U	N/A	N/A	-		-	-	-	640	Inf	Inf	0.0%
7/1		U	N/A	N/A	-		-	-	-	661	Inf	Inf	0.0%
8/1		U	N/A	N/A	-		-	-	-	328	Inf	Inf	0.0%

Item	Arriving (pcu)	Leaving (pcu)	Turners In Gaps (pcu)	Turners When Unopposed (pcu)	Turners In Intergreen (pcu)	Uniform Delay (pcuHr)	Rand + Oversat Delay (pcuHr)	Storage Area Uniform Delay (pcuHr)	Total Delay (pcuHr)	Av. Delay Per PCU (s/pcu)	Max. Back of Uniform Queue (pcu)	Rand + Oversat Queue (pcu)	Mean Max Queue (pcu)
Network: B430/B4030	-	-	8	0	120	51.7	346.3	0.9	398.9	-	-	-	-
B430/B4030	-	-	8	0	120	51.7	346.3	0.9	398.9	-	-	-	-
1/1	602	409	-	-	-	16.9	98.1	-	115.1	688.0	22.9	98.1	121.0
2/1+2/2	647	330	0	0	120	16.4	159.3	0.9	176.6	982.9	26.4	159.3	185.7
3/1	38	38	-	-	-	0.6	0.2	-	0.8	74.8	1.2	0.2	1.4
4/1	1005	833	8	0	0	17.8	88.6	0.0	106.4	381.2	31.8	88.6	120.5
5/1	481	481	-	-	-	0.0	0.0	-	0.0	0.0	0.0	0.0	0.0
6/1	525	525	-	-	-	0.0	0.0	-	0.0	0.0	0.0	0.0	0.0
7/1	435	435	-	-	-	0.0	0.0	-	0.0	0.0	0.0	0.0	0.0
8/1	169	169	-	-	-	0.0	0.0	-	0.0	0.0	0.0	0.0	0.0
C1 PRC for Signalled Lanes (%): -117.6 Total Delay for Signalled Lanes (pcuHr): 398.90 Cycle Time (s): 120 PRC Over All Lanes (%): -117.6 Total Delay Over All Lanes(pcuHr): 398.90													

Scenario 3: '2031 Reference Case + Development AM' (FG3: '2031 Reference Case + Development AM', Plan 1: 'Network Control Plan 1')

Stage Sequence Diagram

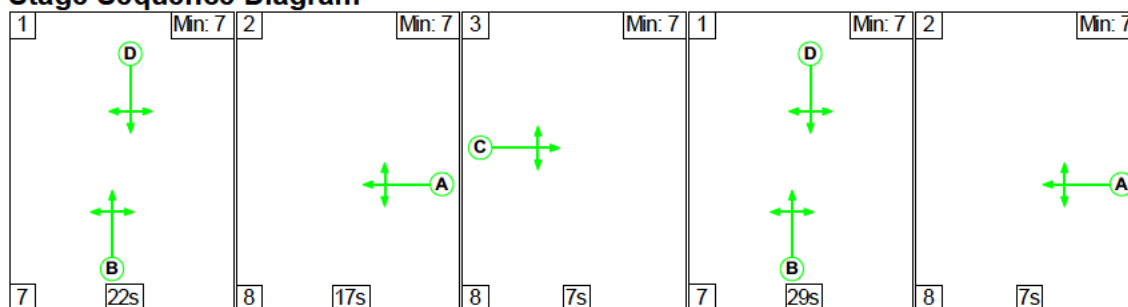

Stage Timings

Stage	1	2	3	1	2
Duration	22	17	7	29	7
Change Point	0	29	54	69	105

Signal Timings Diagram

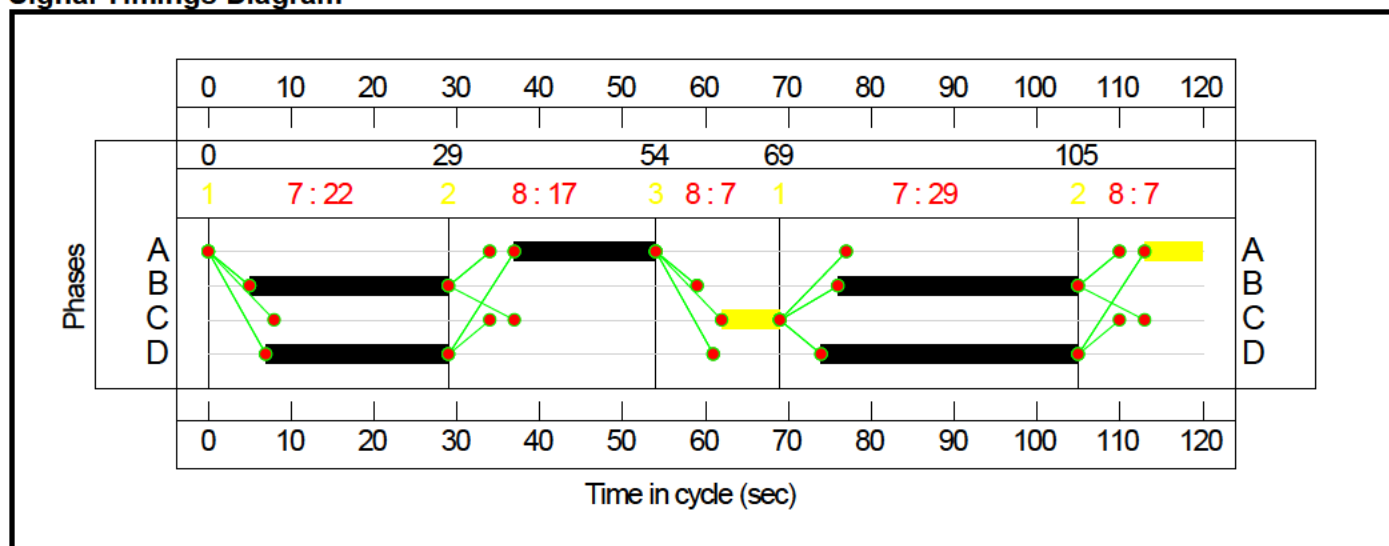

Network Layout Diagram

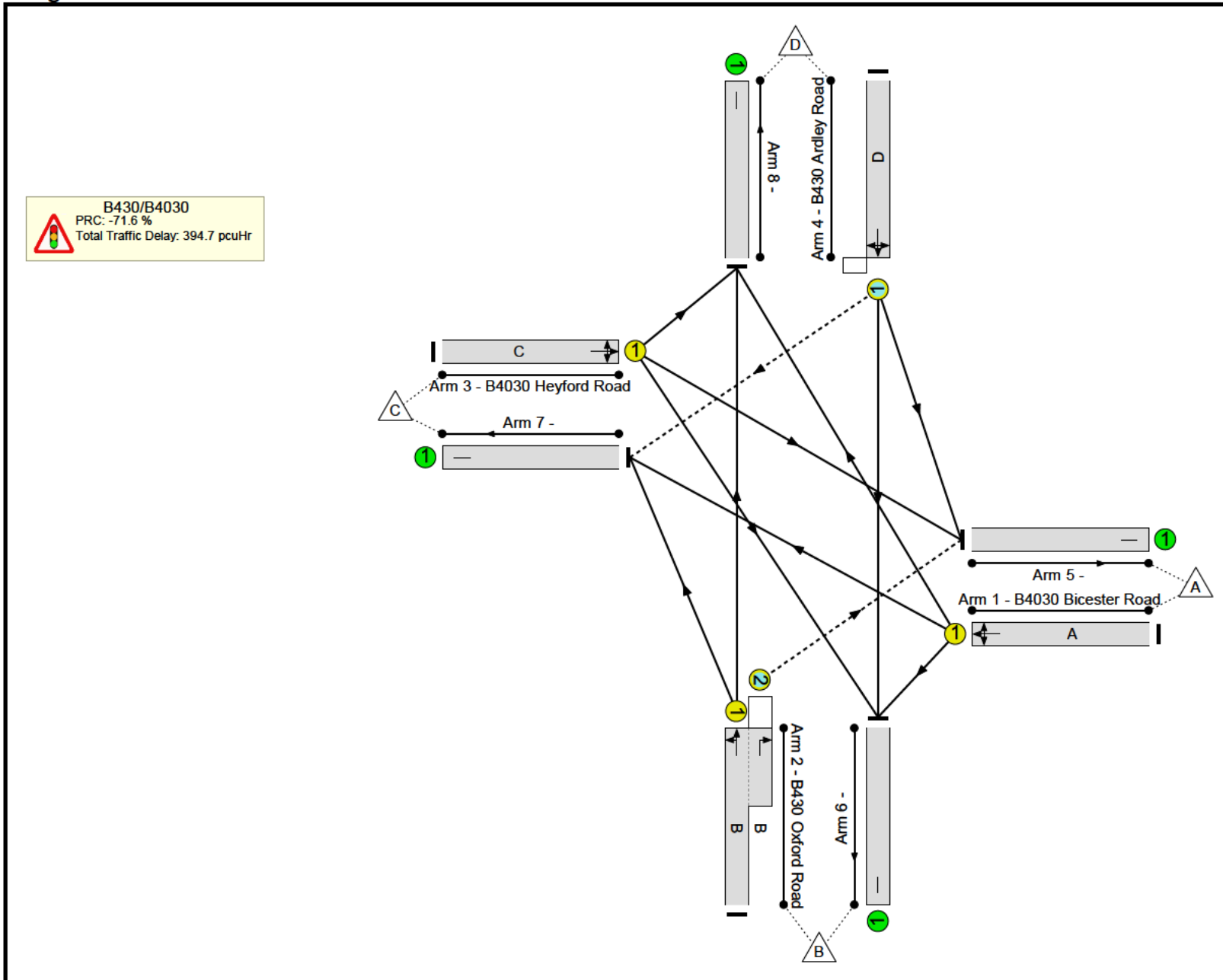

Network Results

Item	Lane Description	Lane Type	Controller Stream	Position In Filtered Route	Full Phase	Arrow Phase	Num Greens	Total Green (s)	Arrow Green (s)	Demand Flow (pcu)	Sat Flow (pcu/Hr)	Capacity (pcu)	Deg Sat (%)
Network: B430/B4030	-	-	N/A	-	-		-	-	-	-	-	-	154.4%
B430/B4030	-	-	N/A	-	-		-	-	-	-	-	-	154.4%
1/1	B4030 Bicester Road Left Ahead Right	U	N/A	N/A	A		2	24	-	598	1799	390	153.4%
2/1+2/2	B430 Oxford Road Right Left Ahead	U+O	N/A	N/A	B		2	53	-	346	1852:1787	739+120	38.3 : 52.5%
3/1	B4030 Heyford Road Ahead Right Left	U	N/A	N/A	C		1	7	-	37	1824	122	30.4%
4/1	B430 Ardley Road Left Ahead Right	O	N/A	N/A	D		2	53	-	1296	1831	839	154.4%
5/1		U	N/A	N/A	-		-	-	-	722	Inf	Inf	0.0%
6/1		U	N/A	N/A	-		-	-	-	792	Inf	Inf	0.0%
7/1		U	N/A	N/A	-		-	-	-	641	Inf	Inf	0.0%
8/1		U	N/A	N/A	-		-	-	-	122	Inf	Inf	0.0%

Item	Arriving (pcu)	Leaving (pcu)	Turners In Gaps (pcu)	Turners When Unopposed (pcu)	Turners In Intergreen (pcu)	Uniform Delay (pcuHr)	Rand + Oversat Delay (pcuHr)	Storage Area Uniform Delay (pcuHr)	Total Delay (pcuHr)	Av. Delay Per PCU (s/pcu)	Max. Back of Uniform Queue (pcu)	Rand + Oversat Queue (pcu)	Mean Max Queue (pcu)
Network: B430/B4030	-	-	8	0	63	58.5	335.9	0.4	394.7	-	-	-	-
B430/B4030	-	-	8	0	63	58.5	335.9	0.4	394.7	-	-	-	-
1/1	598	390	-	-	-	18.0	105.5	-	123.5	743.5	24.3	105.5	129.9
2/1+2/2	346	346	0	0	63	1.1	0.3	0.4	1.9	19.5	4.2	0.3	4.6
3/1	37	37	-	-	-	0.5	0.2	-	0.8	74.6	1.2	0.2	1.4
4/1	1296	839	8	0	0	38.8	229.8	0.0	268.6	746.1	57.8	229.8	287.6
5/1	501	501	-	-	-	0.0	0.0	-	0.0	0.0	0.0	0.0	0.0
6/1	516	516	-	-	-	0.0	0.0	-	0.0	0.0	0.0	0.0	0.0
7/1	484	484	-	-	-	0.0	0.0	-	0.0	0.0	0.0	0.0	0.0
8/1	112	112	-	-	-	0.0	0.0	-	0.0	0.0	0.0	0.0	0.0
C1			PRC for Signalled Lanes (%):		-71.6	Total Delay for Signalled Lanes (pcuHr):		394.75	Cycle Time (s): 120				
			PRC Over All Lanes (%):		-71.6	Total Delay Over All Lanes(pcuHr):		394.75					

Scenario 4: '2031 Reference Case + Development PM' (FG4: '2031 Reference Case + Development PM', Plan 1: 'Network Control Plan 1')

Stage Sequence Diagram

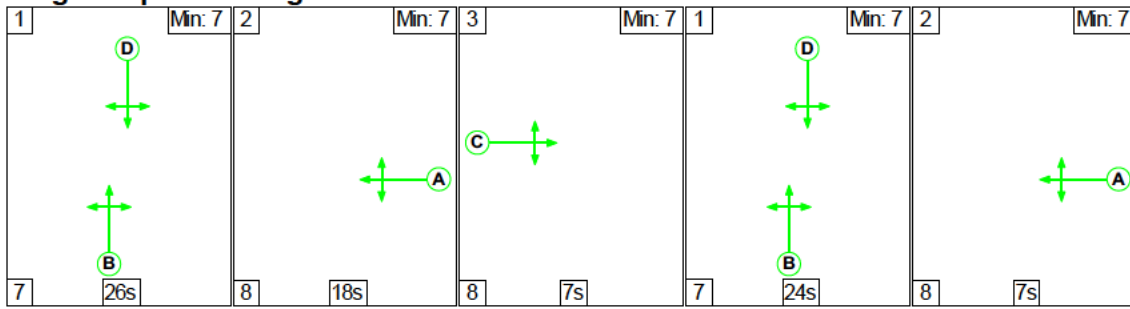

Stage Timings

Stage	1	2	3	1	2
Duration	26	18	7	24	7
Change Point	0	33	59	74	105

Signal Timings Diagram

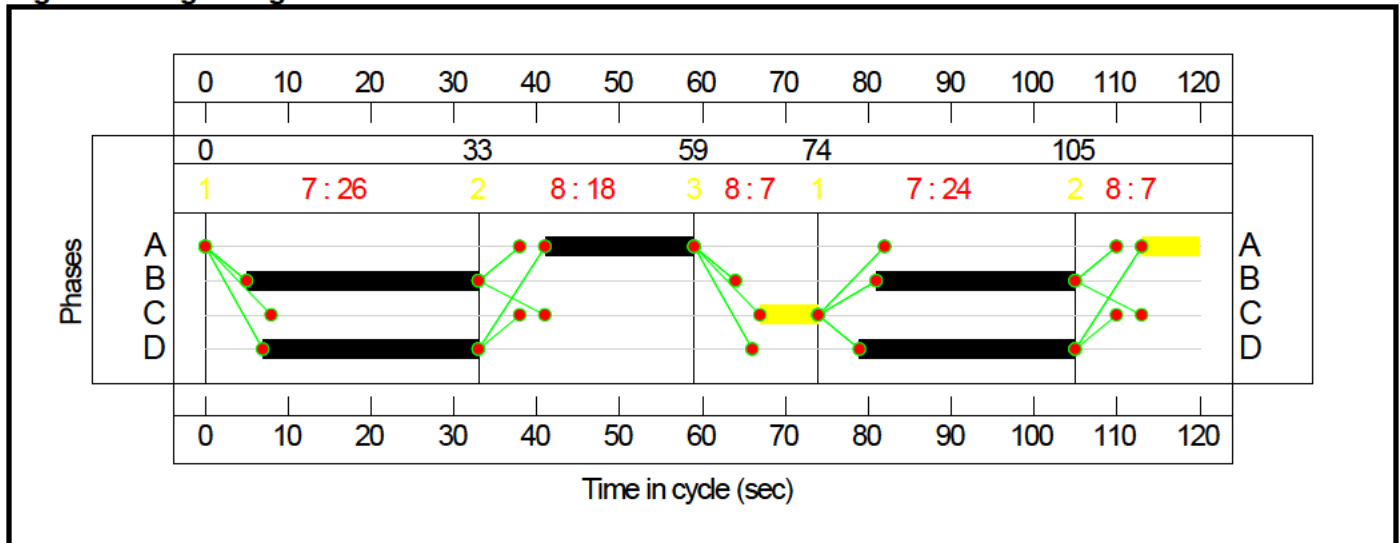

Network Layout Diagram

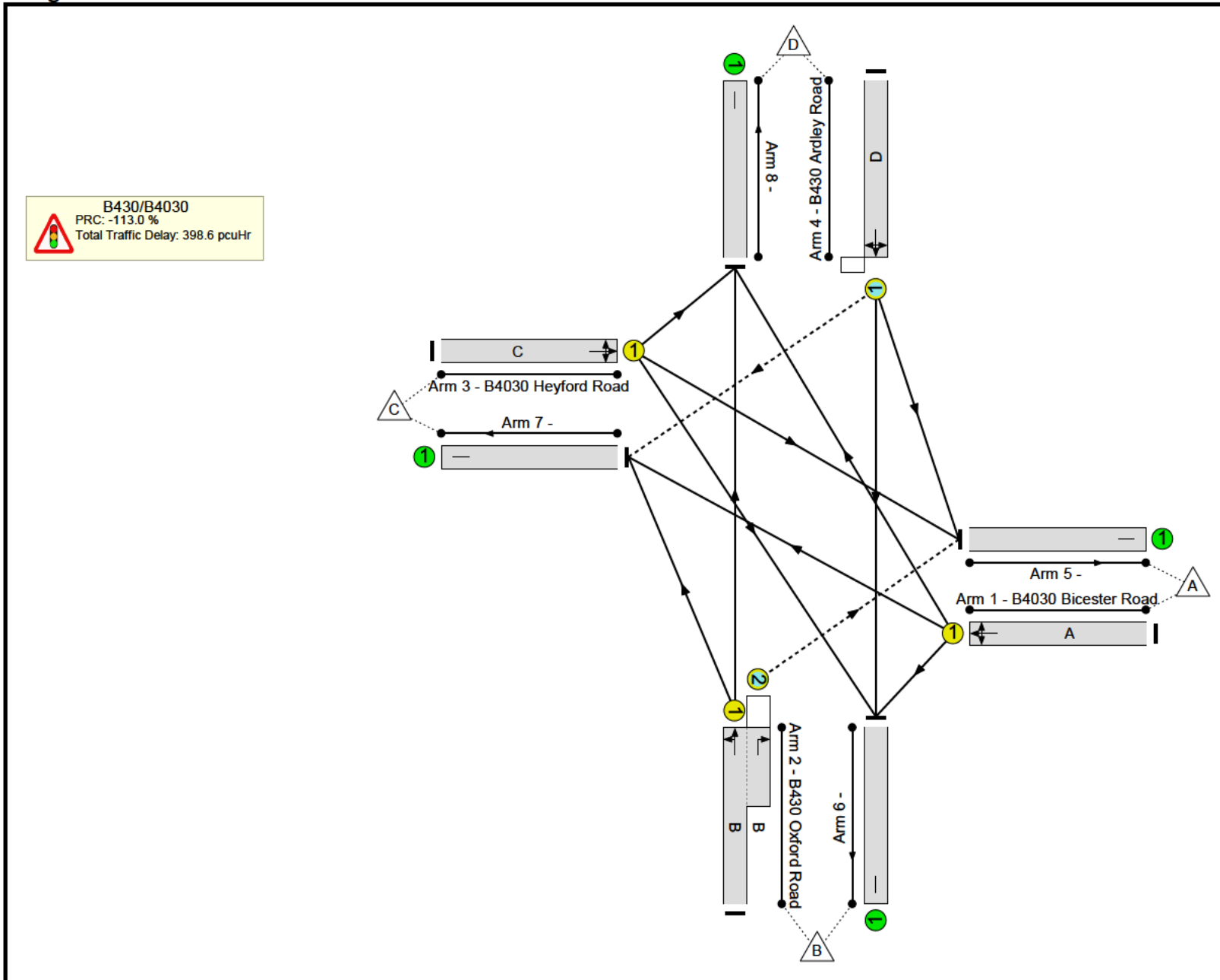

Network Results

Item	Lane Description	Lane Type	Controller Stream	Position In Filtered Route	Full Phase	Arrow Phase	Num Greens	Total Green (s)	Arrow Green (s)	Demand Flow (pcu)	Sat Flow (pcu/Hr)	Capacity (pcu)	Deg Sat (%)
Network: B430/B4030	-	-	N/A	-	-		-	-	-	-	-	-	191.7%
B430/B4030	-	-	N/A	-	-		-	-	-	-	-	-	191.7%
1/1	B4030 Bicester Road Left Ahead Right	U	N/A	N/A	A		2	25	-	597	1816	409	146.1%
2/1+2/2	B430 Oxford Road Right Left Ahead	U+O	N/A	N/A	B		2	52	-	664	1889:1787	226+120	191.7% : 191.7%
3/1	B4030 Heyford Road Ahead Right Left	U	N/A	N/A	C		1	7	-	38	1824	122	31.3%
4/1	B430 Ardley Road Left Ahead Right	O	N/A	N/A	D		2	52	-	1008	1849	832	121.1%
5/1		U	N/A	N/A	-		-	-	-	670	Inf	Inf	0.0%
6/1		U	N/A	N/A	-		-	-	-	635	Inf	Inf	0.0%
7/1		U	N/A	N/A	-		-	-	-	685	Inf	Inf	0.0%
8/1		U	N/A	N/A	-		-	-	-	317	Inf	Inf	0.0%

Item	Arriving (pcu)	Leaving (pcu)	Turners In Gaps (pcu)	Turners When Unopposed (pcu)	Turners In Intergreen (pcu)	Uniform Delay (pcuHr)	Rand + Oversat Delay (pcuHr)	Storage Area Uniform Delay (pcuHr)	Total Delay (pcuHr)	Av. Delay Per PCU (s/pcu)	Max. Back of Uniform Queue (pcu)	Rand + Oversat Queue (pcu)	Mean Max Queue (pcu)
Network: B430/B4030	-	-	8	0	120	51.1	346.6	0.9	398.6	-	-	-	-
B430/B4030	-	-	8	0	120	51.1	346.6	0.9	398.6	-	-	-	-
1/1	597	409	-	-	-	16.6	95.8	-	112.4	677.6	22.4	95.8	118.1
2/1+2/2	664	346	0	0	120	15.8	159.8	0.9	176.5	957.1	25.9	159.8	185.8
3/1	38	38	-	-	-	0.6	0.2	-	0.8	74.8	1.2	0.2	1.4
4/1	1008	832	8	0	0	18.1	90.8	0.0	108.9	388.9	31.9	90.8	122.6
5/1	490	490	-	-	-	0.0	0.0	-	0.0	0.0	0.0	0.0	0.0
6/1	519	519	-	-	-	0.0	0.0	-	0.0	0.0	0.0	0.0	0.0
7/1	451	451	-	-	-	0.0	0.0	-	0.0	0.0	0.0	0.0	0.0
8/1	166	166	-	-	-	0.0	0.0	-	0.0	0.0	0.0	0.0	0.0
C1 PRC for Signalled Lanes (%): -113.0 Total Delay for Signalled Lanes (pcuHr): 398.58 Cycle Time (s): 120 PRC Over All Lanes (%): -113.0 Total Delay Over All Lanes(pcuHr): 398.58													

T19562
Heyford Park



Appendix I

Junctions 10 Output – B430/A4065

Junctions 10
PICADY 10 - Priority Intersection Module
Version: 10 0.2.1576 © Copyright TRL Software Limited, 2021
For sales and distribution information, program advice and maintenance, contact TRL Software: +44 (0)1344 379777 software@trl.co.uk trlsoftware.com
The users of this computer program for the solution of an engineering problem are in no way relieved of their responsibility for the correctness of the solution

Filename: T19562 - B430-A4095 - Crossroads - Copy.j10

Path: C:\Users\MaxLaw\Hub Transport Planning Ltd\Hub Transport Planning - General\Projects\T19562 Heyford Park\Junction Assessments\Picady

Report generation date: 02/12/2021 12:02:01

»2031 Reference Case, AM

»2031 Reference Case, PM

»2031 + Development, AM

»2031 + Development, PM

Summary of junction performance

	AM					PM				
	Set ID	Queue (PCU)	Delay (s)	RFC	LOS	Set ID	Queue (PCU)	Delay (s)	RFC	LOS
2031 Reference Case										
Stream B-CD	D1	1.5	16.43	0.59	C	D2	3.3	32.98	0.78	D
Stream B-AD		0.5	10.58	0.34	B		0.6	13.42	0.39	B
Stream A-D		0.0	6.79	0.00	A		0.1	6.46	0.05	A
Stream D-AB		0.6	17.26	0.39	C		1.0	22.57	0.51	C
Stream D-BC		1.1	28.89	0.54	D		0.8	20.27	0.44	C
Stream C-B		0.1	6.09	0.07	A		0.1	6.39	0.05	A
2031 + Development										
Stream B-CD	D3	1.5	16.63	0.59	C	D4	3.2	32.54	0.77	D
Stream B-AD		0.5	10.62	0.35	B		0.6	13.49	0.39	B
Stream A-D		0.0	6.76	0.00	A		0.1	6.43	0.05	A
Stream D-AB		0.6	17.14	0.39	C		1.2	25.23	0.56	D
Stream D-BC		1.2	29.99	0.56	D		1.0	24.19	0.50	C
Stream C-B		0.1	6.08	0.07	A		0.1	6.50	0.05	A

Values shown are the highest values encountered over all time segments. Delay is the maximum value of average delay per arriving vehicle.

File summary

File Description

Title	B430/A4095
Location	Heyford Park
Site number	
Date	22/11/2021
Version	
Status	(new file)
Identifier	
Client	Richborough Estates
Jobnumber	T19562
Enumerator	HUBTRANSPORTPLANNING\MaxLaw
Description	

Units

Distance units	Speed units	Traffic units input	Traffic units results	Flow units	Average delay units	Total delay units	Rate of delay units
m	kph	PCU	PCU	perHour	s	-Min	perMin

Analysis Options

Vehicle length (m)	Calculate Queue Percentiles	Calculate detailed queueing delay	Show lane queues in feet / metres	Show all PICADY stream intercepts	Calculate residual capacity	RFC Threshold	Average Delay threshold (s)	Queue threshold (PCU)	Use iterations with HCM roundabouts	Max number of iterations for roundabouts
5.75						0.85	36.00	20.00		500

Demand Set Summary

ID	Scenario name	Time Period name	Traffic profile type	Start time (HH mm)	Finish time (HH mm)	Time segment length (min)	Run automatically
D1	2031 Reference Case	AM	ONE HOUR	07:45	09:15	15	✓
D2	2031 Reference Case	PM	ONE HOUR	16:45	18:15	15	✓
D3	2031 + Development	AM	ONE HOUR	07:45	09:15	15	✓
D4	2031 + Development	PM	ONE HOUR	16:45	18:15	15	✓

Analysis Set Details

ID	Include in report	Network flow scaling factor (%)	Network capacity scaling factor (%)
A1	✓	100.000	100.000

2031 Reference Case, AM

Data Errors and Warnings

No errors or warnings

Junction Network

Junctions

Junction	Name	Junction type	Arm A Direction	Arm B Direction	Arm C Direction	Arm D Direction	Use circulating lanes	Junction Delay (s)	Junction LOS
1	untitled	Crossroads	Two-way	Two-way	Two-way	Two-way		7.94	A

Junction Network

Driving side	Lighting	Network delay (s)	Network LOS
Left	Normal/unknown	7.94	A

Arms

Arms

Arm	Name	Description	Arm type
A	B430 (S)		Major
B	A4095 (W)		Minor
C	B430 (N)		Major
D	A4095 (E)		Minor

Major Arm Geometry

Arm	Width of carriageway (m)	Has kerbed central reserve	Has right-turn storage	Width for right-turn storage (m)	Visibility for right turn (m)	Blocks?	Blocking queue (PCU)
A	7.00		✓	3.25	250.0		-
C	7.00		✓	3.25	220.0		-

Geometries for Arm C are measured opposite Arm B. Geometries for Arm A (if relevant) are measured opposite Arm D.

Minor Arm Geometry

Arm	Minor arm type	Lane Width (Left) (m)	Lane Width (Right) (m)	Visibility to left (m)	Visibility to right (m)
B	Two lanes	4.15	4.50	250	200
D	Two lanes	3.80	4.05	230	110

Slope / Intercept / Capacity

Priority Intersection Slopes and Intercepts

Stream	Intercept (PCU/hr)	Slope for A-B	Slope for A-C	Slope for A-D	Slope for B-A	Slope for B-C	Slope for B-D	Slope for C-A	Slope for C-B	Slope for C-D	Slope for D-A	Slope for D-B	Slope for D-C
A-D	801	-	-	-	-	-	-	0.297	0.424	0.297	-	-	-
B-A	769	0.134	0.339	0.339	-	-	-	0.213	0.484	-	0.339	0.339	0.169
B-C	836	0.123	0.310	-	-	-	-	-	-	-	-	-	-
B-D, nearside lane	746	0.130	0.328	0.328	-	-	-	0.207	0.469	0.207	-	-	-
B-D, offside lane	769	0.134	0.339	0.339	-	-	-	0.213	0.484	0.213	-	-	-
C-B	782	0.290	0.290	0.414	-	-	-	-	-	-	-	-	-
D-A	749	-	-	-	-	-	-	0.277	-	0.110	-	-	-
D-B, nearside lane	660	0.183	0.183	0.415	-	-	-	0.291	0.291	0.115	-	-	-
D-B, offside lane	676	0.187	0.187	0.425	-	-	-	0.298	0.298	0.118	-	-	-
D-C	676	-	0.187	0.425	0.149	0.298	0.298	0.298	0.298	0.118	-	-	-

The slopes and intercepts shown above include custom intercept adjustments only.
Streams may be combined, in which case capacity will be adjusted.
Values are shown for the first time segment only; they may differ for subsequent time segments.

Traffic Demand

Demand Set Details

ID	Scenario name	Time Period name	Traffic profile type	Start time (HH mm)	Finish time (HH mm)	Time segment length (min)	Run automatically
D1	2031 Reference Case	AM	ONE HOUR	07:45	09:15	15	✓

Vehicle mix varies over turn	Vehicle mix varies over entry	Vehicle mix source	PCU Factor for a HV (PCU)
✓	✓	HV Percentages	2.00

Demand overview (Traffic)

Arm	Linked arm	Profile type	Use O-D data	Average Demand (PCU/hr)	Scaling Factor (%)
A		ONE HOUR	✓	115	100.000
B		ONE HOUR	✓	460	100.000
C		ONE HOUR	✓	801	100.000
D		ONE HOUR	✓	254	100.000

Origin-Destination Data

Demand (PCU/hr)

		To			
		A	B	C	D
From	A	0	0	113	2
	B	0	0	132	328
	C	737	48	0	16
	D	18	143	93	0

Vehicle Mix

Heavy Vehicle Percentages

		To			
		A	B	C	D
From	A	0	0	0	0
	B	0	0	8	1
	C	1	17	0	0
	D	0	1	0	0

Results

Results Summary for whole modelled period

Stream	Max RFC	Max Delay (s)	Max Queue (PCU)	Max LOS	Average Demand (PCU/hr)	Total Junction Arrivals (PCU)
B-CD	0.59	16.43	1.5	C	272	407
B-AD	0.34	10.58	0.5	B	150	226
A-B					0	0
A-C					104	156
A-D	0.00	6.79	0.0	A	2	3
D-AB	0.39	17.26	0.6	C	103	154
D-BC	0.54	28.89	1.1	D	130	196
C-D					15	22
C-A					676	1014
C-B	0.07	6.09	0.1	A	44	66

Main Results for each time segment

07:45 - 08:00

Stream	Total Demand (PCU/hr)	Junction Arrivals (PCU)	Capacity (PCU/hr)	RFC	Throughput (PCU/hr)	Start queue (PCU)	End queue (PCU)	Delay (s)	Unsignalised level of service
B-CD	223	56	632	0.352	221	0.0	0.6	9.047	A
B-AD	123	31	602	0.205	122	0.0	0.3	7.571	A
A-B	0	0			0				
A-C	85	21			85				
A-D	2	0.38	617	0.002	1	0.0	0.0	5.845	A
D-AB	77	19	455	0.170	77	0.0	0.2	9.572	A
D-BC	114	28	413	0.276	112	0.0	0.4	11 969	B
C-D	12	3			12				
C-A	555	139			555				
C-B	36	9	756	0.048	36	0.0	0.1	5.846	A

08:00 - 08:15

Stream	Total Demand (PCU/hr)	Junction Arrivals (PCU)	Capacity (PCU/hr)	RFC	Throughput (PCU/hr)	Start queue (PCU)	End queue (PCU)	Delay (s)	Unsignalised level of service
B-CD	266	67	600	0.444	265	0.6	0.8	11.150	B
B-AD	147	37	569	0.259	147	0.3	0.3	8.609	A
A-B	0	0			0				
A-C	102	25			102				
A-D	2	0.45	582	0.003	2	0.0	0.0	6.208	A
D-AB	97	24	409	0.238	97	0.2	0.3	11 603	B
D-BC	131	33	356	0.368	130	0.4	0.6	15 934	C
C-D	14	4			14				
C-A	663	166			663				
C-B	43	11	751	0.057	43	0.1	0.1	5.946	A

08:15 - 08:30

Stream	Total Demand (PCU/hr)	Junction Arrivals (PCU)	Capacity (PCU/hr)	RFC	Throughput (PCU/hr)	Start queue (PCU)	End queue (PCU)	Delay (s)	Unsignalised level of service
B-CD	326	81	554	0.589	323	0.8	1.4	16 091	C
B-AD	181	45	524	0.345	180	0.3	0.5	10 543	B
A-B	0	0			0				
A-C	124	31			124				
A-D	2	0.55	532	0.004	2	0.0	0.0	6.790	A
D-AB	133	33	344	0.385	131	0.3	0.6	16 950	C
D-BC	147	37	272	0.540	145	0.6	1.1	27 905	D
C-D	18	4			18				
C-A	811	203			811				
C-B	53	13	745	0.071	53	0.1	0.1	6.088	A

08:30 - 08:45

Stream	Total Demand (PCU/hr)	Junction Arrivals (PCU)	Capacity (PCU/hr)	RFC	Throughput (PCU/hr)	Start queue (PCU)	End queue (PCU)	Delay (s)	Unsignalised level of service
B-CD	326	81	553	0.589	326	1.4	1.5	16.427	C
B-AD	181	45	524	0.345	181	0.5	0.5	10 583	B
A-B	0	0			0				
A-C	124	31			124				
A-D	2	0.55	532	0.004	2	0.0	0.0	6.791	A
D-AB	133	33	343	0.388	133	0.6	0.6	17 259	C
D-BC	146	37	271	0.540	146	1.1	1.1	28 889	D
C-D	18	4			18				
C-A	811	203			811				
C-B	53	13	745	0.071	53	0.1	0.1	6.088	A

08:45 - 09:00

Stream	Total Demand (PCU/hr)	Junction Arrivals (PCU)	Capacity (PCU/hr)	RFC	Throughput (PCU/hr)	Start queue (PCU)	End queue (PCU)	Delay (s)	Unsignalised level of service
B-CD	266	67	600	0.444	269	1.5	0.8	11 396	B
B-AD	147	37	569	0.259	148	0.5	0.4	8.653	A
A-B	0	0			0				
A-C	102	25			102				
A-D	2	0.45	582	0.003	2	0.0	0.0	6.211	A
D-AB	98	24	408	0.240	99	0.6	0.3	11.793	B
D-BC	130	33	354	0.368	133	1.1	0.6	16.428	C
C-D	14	4			14				
C-A	663	166			663				
C-B	43	11	751	0.057	43	0.1	0.1	5.948	A

09:00 - 09:15

Stream	Total Demand (PCU/hr)	Junction Arrivals (PCU)	Capacity (PCU/hr)	RFC	Throughput (PCU/hr)	Start queue (PCU)	End queue (PCU)	Delay (s)	Unsignalised level of service
B-CD	223	56	632	0.353	224	0.8	0.6	9.203	A
B-AD	123	31	602	0.205	124	0.4	0.3	7.615	A
A-B	0	0			0				
A-C	85	21			85				
A-D	2	0.38	617	0.002	2	0.0	0.0	5.846	A
D-AB	78	19	454	0.171	78	0.3	0.2	9.667	A
D-BC	114	28	411	0.276	114	0.6	0.4	12 200	B
C-D	12	3			12				
C-A	555	139			555				
C-B	36	9	756	0.048	36	0.1	0.1	5.849	A

2031 Reference Case, PM

Data Errors and Warnings

No errors or warnings

Junction Network

Junctions

Junction	Name	Junction type	Arm A Direction	Arm B Direction	Arm C Direction	Arm D Direction	Use circulating lanes	Junction Delay (s)	Junction LOS
1	untitled	Crossroads	Two-way	Two-way	Two-way	Two-way		10.50	B

Junction Network

Driving side	Lighting	Network delay (s)	Network LOS
Left	Normal/unknown	10.50	B

Traffic Demand

Demand Set Details

ID	Scenario name	Time Period name	Traffic profile type	Start time (HH mm)	Finish time (HH mm)	Time segment length (min)	Run automatically
D2	2031 Reference Case	PM	ONE HOUR	16:45	18:15	15	✓

Vehicle mix varies over turn	Vehicle mix varies over entry	Vehicle mix source	PCU Factor for a HV (PCU)
✓	✓	HV Percentages	2.00

Demand overview (Traffic)

Arm	Linked arm	Profile type	Use O-D data	Average Demand (PCU/hr)	Scaling Factor (%)
A		ONE HOUR	✓	461	100.000
B		ONE HOUR	✓	496	100.000
C		ONE HOUR	✓	645	100.000
D		ONE HOUR	✓	281	100.000

Origin-Destination Data

Demand (PCU/hr)

		To			
		A	B	C	D
From	A	0	0	435	26
	B	0	0	190	306
	C	609	31	0	5
	D	15	245	21	0

Vehicle Mix

Heavy Vehicle Percentages

		To			
		A	B	C	D
From	A	0	0	1	0
	B	0	0	2	0
	C	0	6	0	0
	D	0	0	0	0

Results

Results Summary for whole modelled period

Stream	Max RFC	Max Delay (s)	Max Queue (PCU)	Max LOS	Average Demand (PCU/hr)	Total Junction Arrivals (PCU)
B-CD	0.78	32.98	3.3	D	315	472
B-AD	0.39	13.42	0.6	B	140	211
A-B					0	0
A-C					399	599
A-D	0.05	6.46	0.1	A	24	36
D-AB	0.51	22.57	1.0	C	135	203
D-BC	0.44	20.27	0.8	C	122	184
C-D					5	7
C-A					559	838
C-B	0.05	6.39	0.1	A	28	43

Main Results for each time segment

16:45 - 17:00

Stream	Total Demand (PCU/hr)	Junction Arrivals (PCU)	Capacity (PCU/hr)	RFC	Throughput (PCU/hr)	Start queue (PCU)	End queue (PCU)	Delay (s)	Unsignalised level of service
B-CD	258	65	591	0.437	255	0.0	0.8	10.750	B
B-AD	115	29	542	0.213	114	0.0	0.3	8.393	A
A-B	0	0			0				
A-C	327	82			327				
A-D	20	5	654	0.030	19	0.0	0.0	5.675	A
D-AB	108	27	438	0.246	106	0.0	0.3	10.826	B
D-BC	104	26	441	0.236	103	0.0	0.3	10.599	B
C-D	4	0.94			4				
C-A	458	115			458				
C-B	23	6	679	0.034	23	0.0	0.0	5.821	A

17:00 - 17:15

Stream	Total Demand (PCU/hr)	Junction Arrivals (PCU)	Capacity (PCU/hr)	RFC	Throughput (PCU/hr)	Start queue (PCU)	End queue (PCU)	Delay (s)	Unsignalised level of service
B-CD	308	77	548	0.563	306	0.8	1.3	14.966	B
B-AD	138	34	498	0.276	137	0.3	0.4	9.970	A
A-B	0	0			0				
A-C	391	98			391				
A-D	23	6	625	0.037	23	0.0	0.0	5.981	A
D-AB	131	33	392	0.334	130	0.3	0.5	13.741	B
D-BC	122	30	392	0.310	121	0.3	0.4	13.246	B
C-D	4	1			4				
C-A	547	137			547				
C-B	28	7	659	0.042	28	0.0	0.0	6.050	A

17:15 - 17:30

Stream	Total Demand (PCU/hr)	Junction Arrivals (PCU)	Capacity (PCU/hr)	RFC	Throughput (PCU/hr)	Start queue (PCU)	End queue (PCU)	Delay (s)	Unsignalised level of service
B-CD	378	94	486	0.778	370	1.3	3.1	29 838	D
B-AD	168	42	437	0.386	168	0.4	0.6	13 326	B
A-B	0	0			0				
A-C	479	120			479				
A-D	29	7	586	0.049	29	0.0	0.1	6.461	A
D-AB	167	42	327	0.511	165	0.5	1.0	21 952	C
D-BC	142	36	320	0.444	141	0.4	0.8	19 901	C
C-D	6	1			6				
C-A	671	168			671				
C-B	34	9	631	0.054	34	0.0	0.1	6.393	A

17:30 - 17:45

Stream	Total Demand (PCU/hr)	Junction Arrivals (PCU)	Capacity (PCU/hr)	RFC	Throughput (PCU/hr)	Start queue (PCU)	End queue (PCU)	Delay (s)	Unsignalised level of service
B-CD	378	94	485	0.778	377	3.1	3.3	32 976	D
B-AD	168	42	437	0.386	168	0.6	0.6	13.417	B
A-B	0	0			0				
A-C	479	120			479				
A-D	29	7	586	0.049	29	0.1	0.1	6.462	A
D-AB	168	42	327	0.513	167	1.0	1.0	22 565	C
D-BC	142	35	319	0.444	142	0.8	0.8	20 266	C
C-D	6	1			6				
C-A	671	168			671				
C-B	34	9	631	0.054	34	0.1	0.1	6.393	A

17:45 - 18:00

Stream	Total Demand (PCU/hr)	Junction Arrivals (PCU)	Capacity (PCU/hr)	RFC	Throughput (PCU/hr)	Start queue (PCU)	End queue (PCU)	Delay (s)	Unsignalised level of service
B-CD	308	77	547	0.564	316	3.3	1.4	16 239	C
B-AD	138	34	498	0.276	138	0.6	0.4	10 049	B
A-B	0	0			0				
A-C	391	98			391				
A-D	23	6	625	0.037	23	0.1	0.0	5.985	A
D-AB	131	33	391	0.336	133	1.0	0.5	14 078	B
D-BC	121	30	391	0.311	123	0.8	0.5	13.474	B
C-D	4	1			4				
C-A	547	137			547				
C-B	28	7	659	0.042	28	0.1	0.0	6.051	A

18:00 - 18:15

Stream	Total Demand (PCU/hr)	Junction Arrivals (PCU)	Capacity (PCU/hr)	RFC	Throughput (PCU/hr)	Start queue (PCU)	End queue (PCU)	Delay (s)	Unsignalised level of service
B-CD	258	65	590	0.438	260	1.4	0.8	11.110	B
B-AD	115	29	542	0.213	116	0.4	0.3	8.457	A
A-B	0	0			0				
A-C	327	82			327				
A-D	20	5	654	0.030	20	0.0	0.0	5.679	A
D-AB	108	27	437	0.247	109	0.5	0.3	10 980	B
D-BC	104	26	440	0.236	104	0.5	0.3	10.732	B
C-D	4	0.94			4				
C-A	458	115			458				
C-B	23	6	679	0.034	23	0.0	0.0	5.826	A

2031 + Development, AM

Data Errors and Warnings

No errors or warnings

Junction Network

Junctions

Junction	Name	Junction type	Arm A Direction	Arm B Direction	Arm C Direction	Arm D Direction	Use circulating lanes	Junction Delay (s)	Junction LOS
1	untitled	Crossroads	Two-way	Two-way	Two-way	Two-way		8.13	A

Junction Network

Driving side	Lighting	Network delay (s)	Network LOS
Left	Normal/unknown	8.13	A

Traffic Demand

Demand Set Details

ID	Scenario name	Time Period name	Traffic profile type	Start time (HH mm)	Finish time (HH mm)	Time segment length (min)	Run automatically
D3	2031 + Development	AM	ONE HOUR	07:45	09:15	15	✓

Vehicle mix varies over turn	Vehicle mix varies over entry	Vehicle mix source	PCU Factor for a HV (PCU)
✓	✓	HV Percentages	2.00

Demand overview (Traffic)

Arm	Linked arm	Profile type	Use O-D data	Average Demand (PCU/hr)	Scaling Factor (%)
A		ONE HOUR	✓	118	100.000
B		ONE HOUR	✓	464	100.000
C		ONE HOUR	✓	794	100.000
D		ONE HOUR	✓	257	100.000

Origin-Destination Data

Demand (PCU/hr)

		To			
		A	B	C	D
From	A	0	0	116	2
	B	0	0	132	332
	C	731	46	0	17
	D	18	141	98	0

Vehicle Mix

Heavy Vehicle Percentages

		To			
		A	B	C	D
From	A	0	0	0	0
	B	0	0	8	1
	C	1	17	0	0
	D	0	0	0	0

Results

Results Summary for whole modelled period

Stream	Max RFC	Max Delay (s)	Max Queue (PCU)	Max LOS	Average Demand (PCU/hr)	Total Junction Arrivals (PCU)
B-CD	0.59	16.63	1.5	C	273	410
B-AD	0.35	10.62	0.5	B	152	228
A-B					0	0
A-C					106	160
A-D	0.00	6.76	0.0	A	2	3
D-AB	0.39	17.14	0.6	C	103	154
D-BC	0.56	29.99	1.2	D	133	200
C-D					16	23
C-A					671	1006
C-B	0.07	6.08	0.1	A	42	63

Main Results for each time segment

07:45 - 08:00

Stream	Total Demand (PCU/hr)	Junction Arrivals (PCU)	Capacity (PCU/hr)	RFC	Throughput (PCU/hr)	Start queue (PCU)	End queue (PCU)	Delay (s)	Unsignalised level of service
B-CD	224	56	632	0.355	222	0.0	0.6	9.091	A
B-AD	125	31	603	0.207	124	0.0	0.3	7.580	A
A-B	0	0			0				
A-C	87	22			87				
A-D	2	0.38	619	0.002	1	0.0	0.0	5.828	A
D-AB	77	19	455	0.169	76	0.0	0.2	9.476	A
D-BC	117	29	412	0.283	115	0.0	0.4	12 072	B
C-D	13	3			13				
C-A	550	138			550				
C-B	35	9	756	0.046	34	0.0	0.1	5.839	A

08:00 - 08:15

Stream	Total Demand (PCU/hr)	Junction Arrivals (PCU)	Capacity (PCU/hr)	RFC	Throughput (PCU/hr)	Start queue (PCU)	End queue (PCU)	Delay (s)	Unsignalised level of service
B-CD	268	67	599	0.447	267	0.6	0.8	11 229	B
B-AD	149	37	570	0.262	149	0.3	0.4	8.625	A
A-B	0	0			0				
A-C	104	26			104				
A-D	2	0.45	584	0.003	2	0.0	0.0	6.186	A
D-AB	97	24	410	0.237	97	0.2	0.3	11.493	B
D-BC	134	33	355	0.377	133	0.4	0.6	16.183	C
C-D	15	4			15				
C-A	657	164			657				
C-B	41	10	751	0.055	41	0.1	0.1	5.938	A

08:15 - 08:30

Stream	Total Demand (PCU/hr)	Junction Arrivals (PCU)	Capacity (PCU/hr)	RFC	Throughput (PCU/hr)	Start queue (PCU)	End queue (PCU)	Delay (s)	Unsignalised level of service
B-CD	328	82	553	0.593	326	0.8	1.5	16 282	C
B-AD	183	46	525	0.348	182	0.4	0.5	10 574	B
A-B	0	0			0				
A-C	128	32			128				
A-D	2	0.55	535	0.004	2	0.0	0.0	6.757	A
D-AB	133	33	344	0.386	132	0.3	0.6	16 824	C
D-BC	150	38	270	0.556	148	0.6	1.2	28 857	D
C-D	19	5			19				
C-A	805	201			805				
C-B	51	13	744	0.068	51	0.1	0.1	6.077	A

08:30 - 08:45

Stream	Total Demand (PCU/hr)	Junction Arrivals (PCU)	Capacity (PCU/hr)	RFC	Throughput (PCU/hr)	Start queue (PCU)	End queue (PCU)	Delay (s)	Unsignalised level of service
B-CD	328	82	553	0.594	328	1.5	1.5	16 634	C
B-AD	183	46	525	0.348	183	0.5	0.5	10 616	B
A-B	0	0			0				
A-C	128	32			128				
A-D	2	0.55	535	0.004	2	0.0	0.0	6.758	A
D-AB	133	33	343	0.389	133	0.6	0.6	17.137	C
D-BC	149	37	269	0.556	149	1.2	1.2	29 992	D
C-D	19	5			19				
C-A	805	201			805				
C-B	51	13	744	0.068	51	0.1	0.1	6.077	A

08:45 - 09:00

Stream	Total Demand (PCU/hr)	Junction Arrivals (PCU)	Capacity (PCU/hr)	RFC	Throughput (PCU/hr)	Start queue (PCU)	End queue (PCU)	Delay (s)	Unsignalised level of service
B-CD	268	67	599	0.447	270	1.5	0.9	11.485	B
B-AD	149	37	570	0.262	150	0.5	0.4	8.672	A
A-B	0	0			0				
A-C	104	26			104				
A-D	2	0.45	584	0.003	2	0.0	0.0	6.189	A
D-AB	98	24	408	0.239	99	0.6	0.3	11 679	B
D-BC	133	33	353	0.378	136	1.2	0.6	16.739	C
C-D	15	4			15				
C-A	657	164			657				
C-B	41	10	751	0.055	41	0.1	0.1	5.939	A

09:00 - 09:15

Stream	Total Demand (PCU/hr)	Junction Arrivals (PCU)	Capacity (PCU/hr)	RFC	Throughput (PCU/hr)	Start queue (PCU)	End queue (PCU)	Delay (s)	Unsignalised level of service
B-CD	224	56	631	0.355	225	0.9	0.6	9.252	A
B-AD	125	31	602	0.207	125	0.4	0.3	7.630	A
A-B	0	0			0				
A-C	87	22			87				
A-D	2	0.38	619	0.002	2	0.0	0.0	5.830	A
D-AB	77	19	454	0.170	78	0.3	0.2	9.570	A
D-BC	116	29	410	0.283	117	0.6	0.4	12 317	B
C-D	13	3			13				
C-A	550	138			550				
C-B	35	9	756	0.046	35	0.1	0.1	5.844	A

2031 + Development, PM

Data Errors and Warnings

No errors or warnings

Junction Network

Junctions

Junction	Name	Junction type	Arm A Direction	Arm B Direction	Arm C Direction	Arm D Direction	Use circulating lanes	Junction Delay (s)	Junction LOS
1	untitled	Crossroads	Two-way	Two-way	Two-way	Two-way		11.07	B

Junction Network

Driving side	Lighting	Network delay (s)	Network LOS
Left	Normal/unknown	11.07	B

Traffic Demand

Demand Set Details

ID	Scenario name	Time Period name	Traffic profile type	Start time (HH mm)	Finish time (HH mm)	Time segment length (min)	Run automatically
D4	2031 + Development	PM	ONE HOUR	16:45	18:15	15	✓

Vehicle mix varies over turn	Vehicle mix varies over entry	Vehicle mix source	PCU Factor for a HV (PCU)
✓	✓	HV Percentages	2.00

Demand overview (Traffic)

Arm	Linked arm	Profile type	Use O-D data	Average Demand (PCU/hr)	Scaling Factor (%)
A		ONE HOUR	✓	464	100.000
B		ONE HOUR	✓	495	100.000
C		ONE HOUR	✓	633	100.000
D		ONE HOUR	✓	299	100.000

Origin-Destination Data

Demand (PCU/hr)

		To			
		A	B	C	D
From	A	0	0	437	27
	B	0	0	187	308
	C	599	29	0	5
	D	15	246	38	0

Vehicle Mix

Heavy Vehicle Percentages

		To			
		A	B	C	D
From	A	0	0	1	0
	B	0	0	2	1
	C	0	8	0	0
	D	0	0	0	0

Results

Results Summary for whole modelled period

Stream	Max RFC	Max Delay (s)	Max Queue (PCU)	Max LOS	Average Demand (PCU/hr)	Total Junction Arrivals (PCU)
B-CD	0.77	32.54	3.2	D	313	469
B-AD	0.39	13.49	0.6	B	141	212
A-B					0	0
A-C					401	601
A-D	0.05	6.43	0.1	A	25	37
D-AB	0.56	25.23	1.2	D	143	215
D-BC	0.50	24.19	1.0	C	131	197
C-D					5	7
C-A					550	824
C-B	0.05	6.50	0.1	A	27	40

Main Results for each time segment

16:45 - 17:00

Stream	Total Demand (PCU/hr)	Junction Arrivals (PCU)	Capacity (PCU/hr)	RFC	Throughput (PCU/hr)	Start queue (PCU)	End queue (PCU)	Delay (s)	Unsignalised level of service
B-CD	257	64	590	0.435	254	0.0	0.8	10.767	B
B-AD	116	29	544	0.213	115	0.0	0.3	8.461	A
A-B	0	0			0				
A-C	329	82			329				
A-D	20	5	657	0.031	20	0.0	0.0	5.654	A
D-AB	111	28	436	0.256	110	0.0	0.3	11 005	B
D-BC	114	28	430	0.264	112	0.0	0.4	11 270	B
C-D	4	0.94			4				
C-A	451	113			451				
C-B	22	5	678	0.032	22	0.0	0.0	5.923	A

17:00 - 17:15

Stream	Total Demand (PCU/hr)	Junction Arrivals (PCU)	Capacity (PCU/hr)	RFC	Throughput (PCU/hr)	Start queue (PCU)	End queue (PCU)	Delay (s)	Unsignalised level of service
B-CD	307	77	547	0.560	305	0.8	1.2	14 946	B
B-AD	138	35	500	0.277	138	0.3	0.4	10 043	B
A-B	0	0			0				
A-C	393	98			393				
A-D	24	6	629	0.039	24	0.0	0.0	5.956	A
D-AB	137	34	389	0.353	136	0.3	0.5	14 250	B
D-BC	132	33	378	0.348	131	0.4	0.5	14 529	B
C-D	4	1			4				
C-A	538	135			538				
C-B	26	7	658	0.040	26	0.0	0.0	6.155	A

17:15 - 17:30

Stream	Total Demand (PCU/hr)	Junction Arrivals (PCU)	Capacity (PCU/hr)	RFC	Throughput (PCU/hr)	Start queue (PCU)	End queue (PCU)	Delay (s)	Unsignalised level of service
B-CD	375	94	485	0.773	368	1.2	3.0	29 540	D
B-AD	170	42	439	0.386	169	0.4	0.6	13 399	B
A-B	0	0			0				
A-C	481	120			481				
A-D	30	7	590	0.050	30	0.0	0.1	6.426	A
D-AB	180	45	324	0.557	178	0.5	1.2	24 226	C
D-BC	149	37	299	0.499	147	0.5	0.9	23 519	C
C-D	6	1			6				
C-A	660	165			660				
C-B	32	8	630	0.051	32	0.0	0.1	6.502	A

17:30 - 17:45

Stream	Total Demand (PCU/hr)	Junction Arrivals (PCU)	Capacity (PCU/hr)	RFC	Throughput (PCU/hr)	Start queue (PCU)	End queue (PCU)	Delay (s)	Unsignalised level of service
B-CD	375	94	485	0.774	375	3.0	3.2	32 544	D
B-AD	170	42	439	0.386	170	0.6	0.6	13.491	B
A-B	0	0			0				
A-C	481	120			481				
A-D	30	7	590	0.050	30	0.1	0.1	6.426	A
D-AB	181	45	323	0.560	181	1.2	1.2	25 229	D
D-BC	148	37	297	0.500	148	0.9	1.0	24.185	C
C-D	6	1			6				
C-A	660	165			660				
C-B	32	8	630	0.051	32	0.1	0.1	6.502	A

17:45 - 18:00

Stream	Total Demand (PCU/hr)	Junction Arrivals (PCU)	Capacity (PCU/hr)	RFC	Throughput (PCU/hr)	Start queue (PCU)	End queue (PCU)	Delay (s)	Unsignalised level of service
B-CD	307	77	547	0.561	314	3.2	1.3	16.183	C
B-AD	138	35	500	0.277	139	0.6	0.4	10.121	B
A-B	0	0			0				
A-C	393	98			393				
A-D	24	6	629	0.039	24	0.1	0.0	5.960	A
D-AB	138	34	388	0.355	140	1.2	0.6	14 676	B
D-BC	131	33	376	0.349	133	1.0	0.5	14 893	B
C-D	4	1			4				
C-A	538	135			538				
C-B	26	7	658	0.040	26	0.1	0.0	6.156	A

18:00 - 18:15

Stream	Total Demand (PCU/hr)	Junction Arrivals (PCU)	Capacity (PCU/hr)	RFC	Throughput (PCU/hr)	Start queue (PCU)	End queue (PCU)	Delay (s)	Unsignalised level of service
B-CD	257	64	590	0.435	259	1.3	0.8	11.121	B
B-AD	116	29	543	0.213	116	0.4	0.3	8.525	A
A-B	0	0			0				
A-C	329	82			329				
A-D	20	5	657	0.031	20	0.0	0.0	5.658	A
D-AB	112	28	435	0.256	112	0.6	0.4	11.187	B
D-BC	114	28	429	0.264	114	0.5	0.4	11.451	B
C-D	4	0.94			4				
C-A	451	113			451				
C-B	22	5	678	0.032	22	0.0	0.0	5.929	A

T19562
Heyford Park



Appendix J

Junctions 10 Output – B4030/Unnamed Road

Junctions 10
PICADY 10 - Priority Intersection Module
Version: 10 0.2.1576 © Copyright TRL Software Limited, 2021
For sales and distribution information, program advice and maintenance, contact TRL Software: +44 (0)1344 379777 software@trl.co.uk trlsoftware.com
The users of this computer program for the solution of an engineering problem are in no way relieved of their responsibility for the correctness of the solution

Filename: T19562 - B4030-Unnamed Road - Existing.j10
Path: C:\Users\MaxLaw\Hub Transport Planning Ltd\Hub Transport Planning - General\Projects\T19562 Heyford Park\Junction Assessments\Picady
Report generation date: 03/12/2021 10:13:17

- »2031 Reference Case, AM
- »2031 Reference Case, PM
- »2031 + Development, AM
- »2031 + Development, PM

Summary of junction performance

	AM					PM				
	Set ID	Queue (PCU)	Delay (s)	RFC	LOS	Set ID	Queue (PCU)	Delay (s)	RFC	LOS
2031 Reference Case										
Stream B-C	D1	0.0	7.77	0.01	A	D2	0.0	6.82	0.01	A
Stream B-A		0.1	9.53	0.07	A		0.1	9.62	0.13	A
Stream C-AB		2.7	16.03	0.71	C		1.8	11.75	0.60	B
2031 + Development										
Stream B-C	D3	0.0	8.17	0.01	A	D4	0.0	8.31	0.01	A
Stream B-A		0.1	10.04	0.12	B		0.2	10.16	0.15	B
Stream C-AB		3.1	17.68	0.74	C		2.2	13.21	0.65	B

Values shown are the highest values encountered over all time segments. Delay is the maximum value of average delay per arriving vehicle.

File summary

File Description

Title	B4030/Unnamed Road
Location	Heyford Park
Site number	
Date	22/11/2021
Version	
Status	(new file)
Identifier	
Client	Richborough Estates
Jobnumber	T19562
Enumerator	HUBTRANSPORTPLANNING\MaxLaw
Description	

Units

Distance units	Speed units	Traffic units input	Traffic units results	Flow units	Average delay units	Total delay units	Rate of delay units
m	kph	PCU	PCU	perHour	s	-Min	perMin

Analysis Options

Vehicle length (m)	Calculate Queue Percentiles	Calculate detailed queueing delay	Show lane queues in feet / metres	Show all PICADY stream intercepts	Calculate residual capacity	RFC Threshold	Average Delay threshold (s)	Queue threshold (PCU)	Use iterations with HCM roundabouts	Max number of iterations for roundabouts
5.75						0.85	36 00	20.00		500

Demand Set Summary

ID	Scenario name	Time Period name	Traffic profile type	Start time (HH mm)	Finish time (HH mm)	Time segment length (min)	Run automatically
D1	2031 Reference Case	AM	ONE HOUR	07:45	09:15	15	✓
D2	2031 Reference Case	PM	ONE HOUR	16:45	18:15	15	✓
D3	2031 + Development	AM	ONE HOUR	07:45	09:15	15	✓
D4	2031 + Development	PM	ONE HOUR	16:45	18:15	15	✓

Analysis Set Details

ID	Include in report	Network flow scaling factor (%)	Network capacity scaling factor (%)
A1	✓	100.000	100.000

2031 Reference Case, AM

Data Errors and Warnings

No errors or warnings

Junction Network

Junctions

Junction	Name	Junction type	Arm A Direction	Arm B Direction	Arm C Direction	Use circulating lanes	Junction Delay (s)	Junction LOS
1	untitled	T-Junction	Two-way	Two-way	Two-way		11.12	B

Junction Network

Driving side	Lighting	Network delay (s)	Network LOS
Left	Normal/unknown	11.12	B

Arms

Arms

Arm	Name	Description	Arm type
A	B4030		Major
B	B4030		Minor
C	untitled		Major

Major Arm Geometry

Arm	Width of carriageway (m)	Has kerbed central reserve	Has right-turn storage	Width for right-turn storage (m)	Visibility for right turn (m)	Blocks?	Blocking queue (PCU)
C	6.50		✓	2.75	125.0	✓	2.00

Geometries for Arm C are measured opposite Arm B. Geometries for Arm A (if relevant) are measured opposite Arm D.

Minor Arm Geometry

Arm	Minor arm type	Width at give-way (m)	Width at 5m (m)	Width at 10m (m)	Width at 15m (m)	Width at 20m (m)	Estimate flare length	Flare length (PCU)	Visibility to left (m)	Visibility to right (m)
B	One lane plus flare	10.00	5.00	5.00	4.50	4.00	✓	2.00	190	105

Slope / Intercept / Capacity

Priority Intersection Slopes and Intercepts

Stream	Intercept (PCU/hr)	Slope for A-B	Slope for A-C	Slope for C-A	Slope for C-B
B-A	659	0.117	0.297	0.187	0.424
B-C	624	0.094	0.236	-	-
C-B	685	0.260	0.260	-	-

The slopes and intercepts shown above include custom intercept adjustments only.

Streams may be combined, in which case capacity will be adjusted.

Values are shown for the first time segment only; they may differ for subsequent time segments.

Traffic Demand

Demand Set Details

ID	Scenario name	Time Period name	Traffic profile type	Start time (HH mm)	Finish time (HH mm)	Time segment length (min)	Run automatically
D1	2031 Reference Case	AM	ONE HOUR	07:45	09:15	15	✓

Vehicle mix varies over turn	Vehicle mix varies over entry	Vehicle mix source	PCU Factor for a HV (PCU)
✓	✓	HV Percentages	2.00

Demand overview (Traffic)

Arm	Linked arm	Profile type	Use O-D data	Average Demand (PCU/hr)	Scaling Factor (%)
A		ONE HOUR	✓	57	100.000
B		ONE HOUR	✓	32	100.000
C		ONE HOUR	✓	620	100.000

Origin-Destination Data

Demand (PCU/hr)

		To		
		A	B	C
From	A	0	42	15
	B	25	0	7
	C	191	429	0

Vehicle Mix

Heavy Vehicle Percentages

		To		
		A	B	C
From	A	0	0	13
	B	0	0	29
	C	5	0	0

Results

Results Summary for whole modelled period

Stream	Max RFC	Max Delay (s)	Max Queue (PCU)	Max LOS	Average Demand (PCU/hr)	Total Junction Arrivals (PCU)
B-C	0.01	7.77	0.0	A	6	10
B-A	0.07	9.53	0.1	A	23	34
C-AB	0.71	16.03	2.7	C	434	652
C-A					134	202
A-B					39	58
A-C					14	21

Main Results for each time segment

07:45 - 08:00

Stream	Total Demand (PCU/hr)	Junction Arrivals (PCU)	Capacity (PCU/hr)	RFC	Throughput (PCU/hr)	Start queue (PCU)	End queue (PCU)	Delay (s)	Unsignalised level of service
B-C	5	1	612	0.009	5	0.0	0.0	7.649	A
B-A	19	5	488	0.039	19	0.0	0.0	7.665	A
C-AB	339	85	707	0.479	335	0.0	0.9	9.616	A
C-A	128	32			128				
A-B	32	8			32				
A-C	11	3			11				

08:00 - 08:15

Stream	Total Demand (PCU/hr)	Junction Arrivals (PCU)	Capacity (PCU/hr)	RFC	Throughput (PCU/hr)	Start queue (PCU)	End queue (PCU)	Delay (s)	Unsignalised level of service
B-C	6	2	609	0.010	6	0.0	0.0	7.698	A
B-A	22	6	454	0.050	22	0.0	0.1	8.350	A
C-AB	418	105	728	0.575	416	0.9	1.4	11 534	B
C-A	139	35			139				
A-B	38	9			38				
A-C	13	3			13				

08:15 - 08:30

Stream	Total Demand (PCU/hr)	Junction Arrivals (PCU)	Capacity (PCU/hr)	RFC	Throughput (PCU/hr)	Start queue (PCU)	End queue (PCU)	Delay (s)	Unsignalised level of service
B-C	8	2	605	0.013	8	0.0	0.0	7.773	A
B-A	28	7	407	0.068	27	0.1	0.1	9.484	A
C-AB	546	137	773	0.707	542	1.4	2.6	15.457	C
C-A	136	34			136				
A-B	46	12			46				
A-C	17	4			17				

08:30 - 08:45

Stream	Total Demand (PCU/hr)	Junction Arrivals (PCU)	Capacity (PCU/hr)	RFC	Throughput (PCU/hr)	Start queue (PCU)	End queue (PCU)	Delay (s)	Unsignalised level of service
B-C	8	2	605	0.013	8	0.0	0.0	7.774	A
B-A	28	7	405	0.068	28	0.1	0.1	9.531	A
C-AB	546	137	774	0.706	546	2.6	2.7	16 032	C
C-A	136	34			136				
A-B	46	12			46				
A-C	17	4			17				

08:45 - 09:00

Stream	Total Demand (PCU/hr)	Junction Arrivals (PCU)	Capacity (PCU/hr)	RFC	Throughput (PCU/hr)	Start queue (PCU)	End queue (PCU)	Delay (s)	Unsignalised level of service
B-C	6	2	609	0.010	6	0.0	0.0	7.702	A
B-A	22	6	451	0.050	23	0.1	0.1	8.405	A
C-AB	418	105	729	0.573	423	2.7	1.5	12 035	B
C-A	139	35			139				
A-B	38	9			38				
A-C	13	3			13				

09:00 - 09:15

Stream	Total Demand (PCU/hr)	Junction Arrivals (PCU)	Capacity (PCU/hr)	RFC	Throughput (PCU/hr)	Start queue (PCU)	End queue (PCU)	Delay (s)	Unsignalised level of service
B-C	5	1	612	0.009	5	0.0	0.0	7.653	A
B-A	19	5	486	0.039	19	0.1	0.0	7.712	A
C-AB	339	85	708	0.479	341	1.5	1.0	9.922	A
C-A	128	32			128				
A-B	32	8			32				
A-C	11	3			11				

2031 Reference Case, PM

Data Errors and Warnings

No errors or warnings

Junction Network

Junctions

Junction	Name	Junction type	Arm A Direction	Arm B Direction	Arm C Direction	Use circulating lanes	Junction Delay (s)	Junction LOS
1	untitled	T-Junction	Two-way	Two-way	Two-way		7.24	A

Junction Network

Driving side	Lighting	Network delay (s)	Network LOS
Left	Normal/unknown	7.24	A

Traffic Demand

Demand Set Details

ID	Scenario name	Time Period name	Traffic profile type	Start time (HH mm)	Finish time (HH mm)	Time segment length (min)	Run automatically
D2	2031 Reference Case	PM	ONE HOUR	16:45	18:15	15	✓

Vehicle mix varies over turn	Vehicle mix varies over entry	Vehicle mix source	PCU Factor for a HV (PCU)
✓	✓	HV Percentages	2.00

Demand overview (Traffic)

Arm	Linked arm	Profile type	Use O-D data	Average Demand (PCU/hr)	Scaling Factor (%)
A		ONE HOUR	✓	35	100.000
B		ONE HOUR	✓	57	100.000
C		ONE HOUR	✓	649	100.000

Origin-Destination Data

Demand (PCU/hr)

		To		
		A	B	C
From	A	0	7	28
	B	50	0	7
	C	279	370	0

Vehicle Mix

Heavy Vehicle Percentages

		To		
		A	B	C
From	A	0	0	36
	B	0	0	7
	C	0	2	0

Results

Results Summary for whole modelled period

Stream	Max RFC	Max Delay (s)	Max Queue (PCU)	Max LOS	Average Demand (PCU/hr)	Total Junction Arrivals (PCU)
B-C	0.01	6.82	0.0	A	6	10
B-A	0.13	9.62	0.1	A	46	69
C-AB	0.60	11.75	1.8	B	378	567
C-A					218	327
A-B					6	10
A-C					26	39

Main Results for each time segment

16:45 - 17:00

Stream	Total Demand (PCU/hr)	Junction Arrivals (PCU)	Capacity (PCU/hr)	RFC	Throughput (PCU/hr)	Start queue (PCU)	End queue (PCU)	Delay (s)	Unsignalised level of service
B-C	5	1	584	0.009	5	0.0	0.0	6.659	A
B-A	38	9	510	0.074	37	0.0	0.1	7.604	A
C-AB	294	73	715	0.411	291	0.0	0.7	8.594	A
C-A	195	49			195				
A-B	5	1			5				
A-C	21	5			21				

17:00 - 17:15

Stream	Total Demand (PCU/hr)	Junction Arrivals (PCU)	Capacity (PCU/hr)	RFC	Throughput (PCU/hr)	Start queue (PCU)	End queue (PCU)	Delay (s)	Unsignalised level of service
B-C	6	2	579	0.011	6	0.0	0.0	6.720	A
B-A	45	11	476	0.094	45	0.1	0.1	8.341	A
C-AB	363	91	739	0.491	362	0.7	1.0	9.704	A
C-A	220	55			220				
A-B	6	2			6				
A-C	25	6			25				

17:15 - 17:30

Stream	Total Demand (PCU/hr)	Junction Arrivals (PCU)	Capacity (PCU/hr)	RFC	Throughput (PCU/hr)	Start queue (PCU)	End queue (PCU)	Delay (s)	Unsignalised level of service
B-C	8	2	573	0.013	8	0.0	0.0	6.814	A
B-A	55	14	430	0.128	55	0.1	0.1	9.583	A
C-AB	476	119	790	0.603	474	1.0	1.7	11.563	B
C-A	238	60			238				
A-B	8	2			8				
A-C	31	8			31				

17:30 - 17:45

Stream	Total Demand (PCU/hr)	Junction Arrivals (PCU)	Capacity (PCU/hr)	RFC	Throughput (PCU/hr)	Start queue (PCU)	End queue (PCU)	Delay (s)	Unsignalised level of service
B-C	8	2	573	0.013	8	0.0	0.0	6.816	A
B-A	55	14	429	0.128	55	0.1	0.1	9.617	A
C-AB	476	119	789	0.603	476	1.7	1.8	11.752	B
C-A	238	60			238				
A-B	8	2			8				
A-C	31	8			31				

17:45 - 18:00

Stream	Total Demand (PCU/hr)	Junction Arrivals (PCU)	Capacity (PCU/hr)	RFC	Throughput (PCU/hr)	Start queue (PCU)	End queue (PCU)	Delay (s)	Unsignalised level of service
B-C	6	2	579	0.011	6	0.0	0.0	6.725	A
B-A	45	11	475	0.095	45	0.1	0.1	8.383	A
C-AB	363	91	739	0.492	366	1.8	1.1	9.912	A
C-A	220	55			220				
A-B	6	2			6				
A-C	25	6			25				

18:00 - 18:15

Stream	Total Demand (PCU/hr)	Junction Arrivals (PCU)	Capacity (PCU/hr)	RFC	Throughput (PCU/hr)	Start queue (PCU)	End queue (PCU)	Delay (s)	Unsignalised level of service
B-C	5	1	583	0.009	5	0.0	0.0	6.662	A
B-A	38	9	509	0.074	38	0.1	0.1	7.648	A
C-AB	294	73	715	0.411	295	1.1	0.8	8.772	A
C-A	195	49			195				
A-B	5	1			5				
A-C	21	5			21				

2031 + Development, AM

Data Errors and Warnings

No errors or warnings

Junction Network

Junctions

Junction	Name	Junction type	Arm A Direction	Arm B Direction	Arm C Direction	Use circulating lanes	Junction Delay (s)	Junction LOS
1	untitled	T-Junction	Two-way	Two-way	Two-way		12.43	B

Junction Network

Driving side	Lighting	Network delay (s)	Network LOS
Left	Normal/unknown	12.43	B

Traffic Demand

Demand Set Details

ID	Scenario name	Time Period name	Traffic profile type	Start time (HH mm)	Finish time (HH mm)	Time segment length (min)	Run automatically
D3	2031 + Development	AM	ONE HOUR	07:45	09:15	15	✓

Vehicle mix varies over turn	Vehicle mix varies over entry	Vehicle mix source	PCU Factor for a HV (PCU)
✓	✓	HV Percentages	2.00

Demand overview (Traffic)

Arm	Linked arm	Profile type	Use O-D data	Average Demand (PCU/hr)	Scaling Factor (%)
A		ONE HOUR	✓	60	100.000
B		ONE HOUR	✓	52	100.000
C		ONE HOUR	✓	633	100.000

Origin-Destination Data

Demand (PCU/hr)

		To		
		A	B	C
From	A	0	45	15
	B	45	0	7
	C	187	446	0

Vehicle Mix

Heavy Vehicle Percentages

		To		
		A	B	C
From	A	0	0	13
	B	0	0	29
	C	5	0	0

Results

Results Summary for whole modelled period

Stream	Max RFC	Max Delay (s)	Max Queue (PCU)	Max LOS	Average Demand (PCU/hr)	Total Junction Arrivals (PCU)
B-C	0.01	8.17	0.0	A	6	10
B-A	0.12	10.04	0.1	B	41	62
C-AB	0.74	17.68	3.1	C	454	681
C-A					127	190
A-B					41	62
A-C					14	21

Main Results for each time segment

07:45 - 08:00

Stream	Total Demand (PCU/hr)	Junction Arrivals (PCU)	Capacity (PCU/hr)	RFC	Throughput (PCU/hr)	Start queue (PCU)	End queue (PCU)	Delay (s)	Unsignalised level of service
B-C	5	1	587	0.009	5	0.0	0.0	7.983	A
B-A	34	8	496	0.068	34	0.0	0.1	7.773	A
C-AB	353	88	708	0.499	349	0.0	1.0	9.949	A
C-A	123	31			123				
A-B	34	8			34				
A-C	11	3			11				

08:00 - 08:15

Stream	Total Demand (PCU/hr)	Junction Arrivals (PCU)	Capacity (PCU/hr)	RFC	Throughput (PCU/hr)	Start queue (PCU)	End queue (PCU)	Delay (s)	Unsignalised level of service
B-C	6	2	583	0.011	6	0.0	0.0	8.054	A
B-A	40	10	460	0.088	40	0.1	0.1	8.585	A
C-AB	437	109	731	0.598	435	1.0	1.6	12.137	B
C-A	132	33			132				
A-B	40	10			40				
A-C	13	3			13				

08:15 - 08:30

Stream	Total Demand (PCU/hr)	Junction Arrivals (PCU)	Capacity (PCU/hr)	RFC	Throughput (PCU/hr)	Start queue (PCU)	End queue (PCU)	Delay (s)	Unsignalised level of service
B-C	8	2	576	0.013	8	0.0	0.0	8.168	A
B-A	50	12	410	0.121	49	0.1	0.1	9.973	A
C-AB	573	143	778	0.736	567	1.6	3.0	16 862	C
C-A	124	31			124				
A-B	50	12			50				
A-C	17	4			17				

08:30 - 08:45

Stream	Total Demand (PCU/hr)	Junction Arrivals (PCU)	Capacity (PCU/hr)	RFC	Throughput (PCU/hr)	Start queue (PCU)	End queue (PCU)	Delay (s)	Unsignalised level of service
B-C	8	2	576	0.013	8	0.0	0.0	8.171	A
B-A	50	12	408	0.121	50	0.1	0.1	10 041	B
C-AB	573	143	779	0.735	572	3.0	3.1	17 679	C
C-A	124	31			124				
A-B	50	12			50				
A-C	17	4			17				

08:45 - 09:00

Stream	Total Demand (PCU/hr)	Junction Arrivals (PCU)	Capacity (PCU/hr)	RFC	Throughput (PCU/hr)	Start queue (PCU)	End queue (PCU)	Delay (s)	Unsignalised level of service
B-C	6	2	583	0.011	6	0.0	0.0	8.058	A
B-A	40	10	456	0.089	41	0.1	0.1	8.661	A
C-AB	437	109	732	0.597	442	3.1	1.7	12 803	B
C-A	132	33			132				
A-B	40	10			40				
A-C	13	3			13				

09:00 - 09:15

Stream	Total Demand (PCU/hr)	Junction Arrivals (PCU)	Capacity (PCU/hr)	RFC	Throughput (PCU/hr)	Start queue (PCU)	End queue (PCU)	Delay (s)	Unsignalised level of service
B-C	5	1	587	0.009	5	0.0	0.0	7.987	A
B-A	34	8	494	0.069	34	0.1	0.1	7.834	A
C-AB	353	88	709	0.498	356	1.7	1.1	10 313	B
C-A	123	31			123				
A-B	34	8			34				
A-C	11	3			11				

2031 + Development, PM

Data Errors and Warnings

No errors or warnings

Junction Network

Junctions

Junction	Name	Junction type	Arm A Direction	Arm B Direction	Arm C Direction	Use circulating lanes	Junction Delay (s)	Junction LOS
1	untitled	T-Junction	Two-way	Two-way	Two-way		8.43	A

Junction Network

Driving side	Lighting	Network delay (s)	Network LOS
Left	Normal/unknown	8.43	A

Traffic Demand

Demand Set Details

ID	Scenario name	Time Period name	Traffic profile type	Start time (HH mm)	Finish time (HH mm)	Time segment length (min)	Run automatically
D4	2031 + Development	PM	ONE HOUR	16:45	18:15	15	✓

Vehicle mix varies over turn	Vehicle mix varies over entry	Vehicle mix source	PCU Factor for a HV (PCU)
✓	✓	HV Percentages	2.00

Demand overview (Traffic)

Arm	Linked arm	Profile type	Use O-D data	Average Demand (PCU/hr)	Scaling Factor (%)
A		ONE HOUR	✓	42	100.000
B		ONE HOUR	✓	62	100.000
C		ONE HOUR	✓	679	100.000

Origin-Destination Data

Demand (PCU/hr)

		To		
		A	B	C
From	A	0	15	27
	B	55	0	7
	C	279	400	0

Vehicle Mix

Heavy Vehicle Percentages

		To		
		A	B	C
From	A	0	0	33
	B	0	0	29
	C	0	2	0

Results

Results Summary for whole modelled period

Stream	Max RFC	Max Delay (s)	Max Queue (PCU)	Max LOS	Average Demand (PCU/hr)	Total Junction Arrivals (PCU)
B-C	0.01	8.31	0.0	A	6	10
B-A	0.15	10.16	0.2	B	50	76
C-AB	0.65	13.21	2.2	B	416	623
C-A					208	311
A-B					14	21
A-C					25	37

Main Results for each time segment

16:45 - 17:00

Stream	Total Demand (PCU/hr)	Junction Arrivals (PCU)	Capacity (PCU/hr)	RFC	Throughput (PCU/hr)	Start queue (PCU)	End queue (PCU)	Delay (s)	Unsignalised level of service
B-C	5	1	580	0.009	5	0.0	0.0	8.086	A
B-A	41	10	502	0.083	41	0.0	0.1	7.811	A
C-AB	320	80	720	0.445	317	0.0	0.9	9.038	A
C-A	191	48			191				
A-B	11	3			11				
A-C	20	5			20				

17:00 - 17:15

Stream	Total Demand (PCU/hr)	Junction Arrivals (PCU)	Capacity (PCU/hr)	RFC	Throughput (PCU/hr)	Start queue (PCU)	End queue (PCU)	Delay (s)	Unsignalised level of service
B-C	6	2	575	0.011	6	0.0	0.0	8.169	A
B-A	49	12	465	0.106	49	0.1	0.1	8.655	A
C-AB	398	100	748	0.532	397	0.9	1.2	10.409	B
C-A	212	53			212				
A-B	13	3			13				
A-C	24	6			24				

17:15 - 17:30

Stream	Total Demand (PCU/hr)	Junction Arrivals (PCU)	Capacity (PCU/hr)	RFC	Throughput (PCU/hr)	Start queue (PCU)	End queue (PCU)	Delay (s)	Unsignalised level of service
B-C	8	2	567	0.014	8	0.0	0.0	8.302	A
B-A	61	15	416	0.146	60	0.1	0.2	10.113	B
C-AB	528	132	807	0.654	524	1.2	2.2	12 893	B
C-A	220	55			220				
A-B	17	4			17				
A-C	30	7			30				

17:30 - 17:45

Stream	Total Demand (PCU/hr)	Junction Arrivals (PCU)	Capacity (PCU/hr)	RFC	Throughput (PCU/hr)	Start queue (PCU)	End queue (PCU)	Delay (s)	Unsignalised level of service
B-C	8	2	567	0.014	8	0.0	0.0	8.305	A
B-A	61	15	415	0.146	61	0.2	0.2	10.162	B
C-AB	528	132	807	0.654	528	2.2	2.2	13 212	B
C-A	220	55			220				
A-B	17	4			17				
A-C	30	7			30				

17:45 - 18:00

Stream	Total Demand (PCU/hr)	Junction Arrivals (PCU)	Capacity (PCU/hr)	RFC	Throughput (PCU/hr)	Start queue (PCU)	End queue (PCU)	Delay (s)	Unsignalised level of service
B-C	6	2	574	0.011	6	0.0	0.0	8.175	A
B-A	49	12	463	0.107	50	0.2	0.1	8.712	A
C-AB	398	100	748	0.533	402	2.2	1.3	10.732	B
C-A	212	53			212				
A-B	13	3			13				
A-C	24	6			24				

18:00 - 18:15

Stream	Total Demand (PCU/hr)	Junction Arrivals (PCU)	Capacity (PCU/hr)	RFC	Throughput (PCU/hr)	Start queue (PCU)	End queue (PCU)	Delay (s)	Unsignalised level of service
B-C	5	1	579	0.009	5	0.0	0.0	8.090	A
B-A	41	10	499	0.083	42	0.1	0.1	7.863	A
C-AB	320	80	719	0.445	322	1.3	0.9	9.273	A
C-A	191	48			191				
A-B	11	3			11				
A-C	20	5			20				

T19562
Heyford Park



Appendix K

Junctions 10 Output – Camp Road/Kirklington Road

Junctions 10
PICADY 10 - Priority Intersection Module
Version: 10 0.2.1576 © Copyright TRL Software Limited, 2021
For sales and distribution information, program advice and maintenance, contact TRL Software: +44 (0)1344 379777 software@trl.co.uk trlsoftware.com
The users of this computer program for the solution of an engineering problem are in no way relieved of their responsibility for the correctness of the solution

Filename: T19562 - Camp Rd-Kirtlington Rd.j10

Path: C:\Users\MaxLaw\Hub Transport Planning Ltd\Hub Transport Planning - General\Projects\T19562 Heyford Park\Junction Assessments\Picady

Report generation date: 02/12/2021 11:56:29

»2031 Reference Case, AM

»2031 Reference Case, PM

»2031 + Development, AM

»2031 + Development, PM

Summary of junction performance

	AM					PM				
	Set ID	Queue (PCU)	Delay (s)	RFC	LOS	Set ID	Queue (PCU)	Delay (s)	RFC	LOS
2031 Reference Case										
Stream B-AC	D1	0.2	10.51	0.16	B	D2	0.4	11.58	0.27	B
Stream C-AB		0.0	0.00	0.00	A		0.0	0.00	0.00	A
2031 + Development										
Stream B-AC	D3	0.2	10.65	0.16	B	D4	0.4	11.69	0.27	B
Stream C-AB		0.0	0.00	0.00	A		0.0	0.00	0.00	A

Values shown are the highest values encountered over all time segments. Delay is the maximum value of average delay per arriving vehicle.

File summary

File Description

Title	Camp Road/Kirtlington Road
Location	Heyford Park
Site number	
Date	22/11/2021
Version	
Status	(new file)
Identifier	
Client	Richborough Estates
Jobnumber	T19562
Enumerator	HUBTRANSPORTPLANNING\MaxLaw
Description	

Units

Distance units	Speed units	Traffic units input	Traffic units results	Flow units	Average delay units	Total delay units	Rate of delay units
m	kph	PCU	PCU	perHour	s	-Min	perMin

Analysis Options

Vehicle length (m)	Calculate Queue Percentiles	Calculate detailed queueing delay	Show lane queues in feet / metres	Show all PICADY stream intercepts	Calculate residual capacity	RFC Threshold	Average Delay threshold (s)	Queue threshold (PCU)	Use iterations with HCM roundabouts	Max number of iterations for roundabouts
5.75						0.85	36.00	20.00		500

Demand Set Summary

ID	Scenario name	Time Period name	Traffic profile type	Start time (HH mm)	Finish time (HH mm)	Time segment length (min)	Run automatically
D1	2031 Reference Case	AM	ONE HOUR	07:45	09:15	15	✓
D2	2031 Reference Case	PM	ONE HOUR	16:45	18:15	15	✓
D3	2031 + Development	AM	ONE HOUR	07:45	09:15	15	✓
D4	2031 + Development	PM	ONE HOUR	16:45	18:15	15	✓

Analysis Set Details

ID	Include in report	Network flow scaling factor (%)	Network capacity scaling factor (%)
A1	✓	100.000	100.000

2031 Reference Case, AM

Data Errors and Warnings

No errors or warnings

Junction Network

Junctions

Junction	Name	Junction type	Arm A Direction	Arm B Direction	Arm C Direction	Use circulating lanes	Junction Delay (s)	Junction LOS
1	untitled	T-Junction	Two-way	Two-way	Two-way		0.93	A

Junction Network

Driving side	Lighting	Network delay (s)	Network LOS
Left	Normal/unknown	0.93	A

Arms

Arms

Arm	Name	Description	Arm type
A	untitled		Major
B	untitled		Minor
C	untitled		Major

Major Arm Geometry

Arm	Width of carriageway (m)	Has kerbed central reserve	Has right-turn storage	Visibility for right turn (m)	Blocks?	Blocking queue (PCU)
C	6.00			200.0	✓	0.00

Geometries for Arm C are measured opposite Arm B. Geometries for Arm A (if relevant) are measured opposite Arm D.

Minor Arm Geometry

Arm	Minor arm type	Lane width (m)	Visibility to left (m)	Visibility to right (m)
B	One lane	3.40	18	25

Slope / Intercept / Capacity

Priority Intersection Slopes and Intercepts

Stream	Intercept (PCU/hr)	Slope for A-B	Slope for A-C	Slope for C-A	Slope for C-B
B-A	516	0.094	0.237	0.149	0.339
B-C	665	0.102	0.258	-	-
C-B	690	0.267	0.267	-	-

The slopes and intercepts shown above include custom intercept adjustments only.

Streams may be combined, in which case capacity will be adjusted.

Values are shown for the first time segment only; they may differ for subsequent time segments.

Traffic Demand

Demand Set Details

ID	Scenario name	Time Period name	Traffic profile type	Start time (HH mm)	Finish time (HH mm)	Time segment length (min)	Run automatically
D1	2031 Reference Case	AM	ONE HOUR	07:45	09:15	15	✓

Vehicle mix varies over turn	Vehicle mix varies over entry	Vehicle mix source	PCU Factor for a HV (PCU)
✓	✓	HV Percentages	2.00

Demand overview (Traffic)

Arm	Linked arm	Profile type	Use O-D data	Average Demand (PCU/hr)	Scaling Factor (%)
A		ONE HOUR	✓	387	100.000
B		ONE HOUR	✓	58	100.000
C		ONE HOUR	✓	211	100.000

Origin-Destination Data

Demand (PCU/hr)

		To			
		A	B	C	
From	A	0	168	219	
	B	58	0	0	
	C	211	0	0	

Vehicle Mix

Heavy Vehicle Percentages

		To			
		A	B	C	
From	A	0	0	1	
	B	0	0	0	
	C	1	0	0	

Results

Results Summary for whole modelled period

Stream	Max RFC	Max Delay (s)	Max Queue (PCU)	Max LOS	Average Demand (PCU/hr)	Total Junction Arrivals (PCU)
B-AC	0.16	10.51	0.2	B	53	80
C-AB	0.00	0.00	0.0	A	0	0
C-A					194	290
A-B					154	231
A-C					201	301

Main Results for each time segment

07:45 - 08:00

Stream	Total Demand (PCU/hr)	Junction Arrivals (PCU)	Capacity (PCU/hr)	RFC	Throughput (PCU/hr)	Start queue (PCU)	End queue (PCU)	Delay (s)	Unsignalised level of service
B-AC	44	11	441	0.099	43	0.0	0.1	9.044	A
C-AB	0	0	612	0.000	0	0.0	0.0	0.000	A
C-A	159	40			159				
A-B	126	32			126				
A-C	165	41			165				

08:00 - 08:15

Stream	Total Demand (PCU/hr)	Junction Arrivals (PCU)	Capacity (PCU/hr)	RFC	Throughput (PCU/hr)	Start queue (PCU)	End queue (PCU)	Delay (s)	Unsignalised level of service
B-AC	52	13	426	0.122	52	0.1	0.1	9.614	A
C-AB	0	0	597	0.000	0	0.0	0.0	0.000	A
C-A	190	47			190				
A-B	151	38			151				
A-C	197	49			197				

08:15 - 08:30

Stream	Total Demand (PCU/hr)	Junction Arrivals (PCU)	Capacity (PCU/hr)	RFC	Throughput (PCU/hr)	Start queue (PCU)	End queue (PCU)	Delay (s)	Unsignalised level of service
B-AC	64	16	406	0.157	64	0.1	0.2	10 502	B
C-AB	0	0	576	0.000	0	0.0	0.0	0.000	A
C-A	232	58			232				
A-B	185	46			185				
A-C	241	60			241				

08:30 - 08:45

Stream	Total Demand (PCU/hr)	Junction Arrivals (PCU)	Capacity (PCU/hr)	RFC	Throughput (PCU/hr)	Start queue (PCU)	End queue (PCU)	Delay (s)	Unsignalised level of service
B-AC	64	16	406	0.157	64	0.2	0.2	10 512	B
C-AB	0	0	576	0.000	0	0.0	0.0	0.000	A
C-A	232	58			232				
A-B	185	46			185				
A-C	241	60			241				

08:45 - 09:00

Stream	Total Demand (PCU/hr)	Junction Arrivals (PCU)	Capacity (PCU/hr)	RFC	Throughput (PCU/hr)	Start queue (PCU)	End queue (PCU)	Delay (s)	Unsignalised level of service
B-AC	52	13	426	0.122	52	0.2	0.1	9.629	A
C-AB	0	0	597	0.000	0	0.0	0.0	0.000	A
C-A	190	47			190				
A-B	151	38			151				
A-C	197	49			197				

09:00 - 09:15

Stream	Total Demand (PCU/hr)	Junction Arrivals (PCU)	Capacity (PCU/hr)	RFC	Throughput (PCU/hr)	Start queue (PCU)	End queue (PCU)	Delay (s)	Unsignalised level of service
B-AC	44	11	441	0.099	44	0.1	0.1	9.070	A
C-AB	0	0	612	0.000	0	0.0	0.0	0.000	A
C-A	159	40			159				
A-B	126	32			126				
A-C	165	41			165				

2031 Reference Case, PM

Data Errors and Warnings

No errors or warnings

Junction Network

Junctions

Junction	Name	Junction type	Arm A Direction	Arm B Direction	Arm C Direction	Use circulating lanes	Junction Delay (s)	Junction LOS
1	untitled	T-Junction	Two-way	Two-way	Two-way		2.14	A

Junction Network

Driving side	Lighting	Network delay (s)	Network LOS
Left	Normal/unknown	2.14	A

Traffic Demand

Demand Set Details

ID	Scenario name	Time Period name	Traffic profile type	Start time (HH mm)	Finish time (HH mm)	Time segment length (min)	Run automatically
D2	2031 Reference Case	PM	ONE HOUR	16:45	18:15	15	✓

Vehicle mix varies over turn	Vehicle mix varies over entry	Vehicle mix source	PCU Factor for a HV (PCU)
✓	✓	HV Percentages	2.00

Demand overview (Traffic)

Arm	Linked arm	Profile type	Use O-D data	Average Demand (PCU/hr)	Scaling Factor (%)
A		ONE HOUR	✓	241	100.000
B		ONE HOUR	✓	103	100.000
C		ONE HOUR	✓	212	100.000

Origin-Destination Data

Demand (PCU/hr)

		To		
		A	B	C
From	A	0	42	199
	B	103	0	0
	C	212	0	0

Vehicle Mix

Heavy Vehicle Percentages

		To		
		A	B	C
From	A	0	0	2
	B	0	0	0
	C	3	0	0

Results

Results Summary for whole modelled period

Stream	Max RFC	Max Delay (s)	Max Queue (PCU)	Max LOS	Average Demand (PCU/hr)	Total Junction Arrivals (PCU)
B-AC	0.27	11.58	0.4	B	95	142
C-AB	0.00	0.00	0.0	A	0	0
C-A					195	292
A-B					39	58
A-C					183	274

Main Results for each time segment

16:45 - 17:00

Stream	Total Demand (PCU/hr)	Junction Arrivals (PCU)	Capacity (PCU/hr)	RFC	Throughput (PCU/hr)	Start queue (PCU)	End queue (PCU)	Delay (s)	Unsignalised level of service
B-AC	78	19	453	0.171	77	0.0	0.2	9.543	A
C-AB	0	0	641	0.000	0	0.0	0.0	0.000	A
C-A	160	40			160				
A-B	32	8			32				
A-C	150	37			150				

17:00 - 17:15

Stream	Total Demand (PCU/hr)	Junction Arrivals (PCU)	Capacity (PCU/hr)	RFC	Throughput (PCU/hr)	Start queue (PCU)	End queue (PCU)	Delay (s)	Unsignalised level of service
B-AC	93	23	441	0.210	92	0.2	0.3	10 315	B
C-AB	0	0	632	0.000	0	0.0	0.0	0.000	A
C-A	191	48			191				
A-B	38	9			38				
A-C	179	45			179				

17:15 - 17:30

Stream	Total Demand (PCU/hr)	Junction Arrivals (PCU)	Capacity (PCU/hr)	RFC	Throughput (PCU/hr)	Start queue (PCU)	End queue (PCU)	Delay (s)	Unsignalised level of service
B-AC	113	28	424	0.267	113	0.3	0.4	11 546	B
C-AB	0	0	619	0.000	0	0.0	0.0	0.000	A
C-A	233	58			233				
A-B	46	12			46				
A-C	219	55			219				

17:30 - 17:45

Stream	Total Demand (PCU/hr)	Junction Arrivals (PCU)	Capacity (PCU/hr)	RFC	Throughput (PCU/hr)	Start queue (PCU)	End queue (PCU)	Delay (s)	Unsignalised level of service
B-AC	113	28	424	0.267	113	0.4	0.4	11 576	B
C-AB	0	0	619	0.000	0	0.0	0.0	0.000	A
C-A	233	58			233				
A-B	46	12			46				
A-C	219	55			219				

17:45 - 18:00

Stream	Total Demand (PCU/hr)	Junction Arrivals (PCU)	Capacity (PCU/hr)	RFC	Throughput (PCU/hr)	Start queue (PCU)	End queue (PCU)	Delay (s)	Unsignalised level of service
B-AC	93	23	441	0.210	93	0.4	0.3	10 353	B
C-AB	0	0	632	0.000	0	0.0	0.0	0.000	A
C-A	191	48			191				
A-B	38	9			38				
A-C	179	45			179				

18:00 - 18:15

Stream	Total Demand (PCU/hr)	Junction Arrivals (PCU)	Capacity (PCU/hr)	RFC	Throughput (PCU/hr)	Start queue (PCU)	End queue (PCU)	Delay (s)	Unsignalised level of service
B-AC	78	19	453	0.171	78	0.3	0.2	9.595	A
C-AB	0	0	641	0.000	0	0.0	0.0	0.000	A
C-A	160	40			160				
A-B	32	8			32				
A-C	150	37			150				

2031 + Development, AM

Data Errors and Warnings

No errors or warnings

Junction Network

Junctions

Junction	Name	Junction type	Arm A Direction	Arm B Direction	Arm C Direction	Use circulating lanes	Junction Delay (s)	Junction LOS
1	untitled	T-Junction	Two-way	Two-way	Two-way		0.91	A

Junction Network

Driving side	Lighting	Network delay (s)	Network LOS
Left	Normal/unknown	0.91	A

Traffic Demand

Demand Set Details

ID	Scenario name	Time Period name	Traffic profile type	Start time (HH mm)	Finish time (HH mm)	Time segment length (min)	Run automatically
D3	2031 + Development	AM	ONE HOUR	07:45	09:15	15	✓

Vehicle mix varies over turn	Vehicle mix varies over entry	Vehicle mix source	PCU Factor for a HV (PCU)
✓	✓	HV Percentages	2.00

Demand overview (Traffic)

Arm	Linked arm	Profile type	Use O-D data	Average Demand (PCU/hr)	Scaling Factor (%)
A		ONE HOUR	✓	404	100.000
B		ONE HOUR	✓	58	100.000
C		ONE HOUR	✓	215	100.000

Origin-Destination Data

Demand (PCU/hr)

		To		
		A	B	C
From	A	0	172	232
	B	58	0	0
	C	215	0	0

Vehicle Mix

Heavy Vehicle Percentages

		To		
		A	B	C
From	A	0	0	1
	B	0	0	0
	C	1	0	0

Results

Results Summary for whole modelled period

Stream	Max RFC	Max Delay (s)	Max Queue (PCU)	Max LOS	Average Demand (PCU/hr)	Total Junction Arrivals (PCU)
B-AC	0.16	10.65	0.2	B	53	80
C-AB	0.00	0.00	0.0	A	0	0
C-A					197	296
A-B					158	237
A-C					213	319

Main Results for each time segment

07:45 - 08:00

Stream	Total Demand (PCU/hr)	Junction Arrivals (PCU)	Capacity (PCU/hr)	RFC	Throughput (PCU/hr)	Start queue (PCU)	End queue (PCU)	Delay (s)	Unsignalised level of service
B-AC	44	11	438	0.100	43	0.0	0.1	9.114	A
C-AB	0	0	608	0.000	0	0.0	0.0	0.000	A
C-A	162	40			162				
A-B	129	32			129				
A-C	175	44			175				

08:00 - 08:15

Stream	Total Demand (PCU/hr)	Junction Arrivals (PCU)	Capacity (PCU/hr)	RFC	Throughput (PCU/hr)	Start queue (PCU)	End queue (PCU)	Delay (s)	Unsignalised level of service
B-AC	52	13	423	0.123	52	0.1	0.1	9.709	A
C-AB	0	0	593	0.000	0	0.0	0.0	0.000	A
C-A	193	48			193				
A-B	155	39			155				
A-C	209	52			209				

08:15 - 08:30

Stream	Total Demand (PCU/hr)	Junction Arrivals (PCU)	Capacity (PCU/hr)	RFC	Throughput (PCU/hr)	Start queue (PCU)	End queue (PCU)	Delay (s)	Unsignalised level of service
B-AC	64	16	402	0.159	64	0.1	0.2	10 641	B
C-AB	0	0	571	0.000	0	0.0	0.0	0.000	A
C-A	237	59			237				
A-B	189	47			189				
A-C	255	64			255				

08:30 - 08:45

Stream	Total Demand (PCU/hr)	Junction Arrivals (PCU)	Capacity (PCU/hr)	RFC	Throughput (PCU/hr)	Start queue (PCU)	End queue (PCU)	Delay (s)	Unsignalised level of service
B-AC	64	16	402	0.159	64	0.2	0.2	10 651	B
C-AB	0	0	571	0.000	0	0.0	0.0	0.000	A
C-A	237	59			237				
A-B	189	47			189				
A-C	255	64			255				

08:45 - 09:00

Stream	Total Demand (PCU/hr)	Junction Arrivals (PCU)	Capacity (PCU/hr)	RFC	Throughput (PCU/hr)	Start queue (PCU)	End queue (PCU)	Delay (s)	Unsignalised level of service
B-AC	52	13	423	0.123	52	0.2	0.1	9.726	A
C-AB	0	0	593	0.000	0	0.0	0.0	0.000	A
C-A	193	48			193				
A-B	155	39			155				
A-C	209	52			209				

09:00 - 09:15

Stream	Total Demand (PCU/hr)	Junction Arrivals (PCU)	Capacity (PCU/hr)	RFC	Throughput (PCU/hr)	Start queue (PCU)	End queue (PCU)	Delay (s)	Unsignalised level of service
B-AC	44	11	438	0.100	44	0.1	0.1	9.139	A
C-AB	0	0	608	0.000	0	0.0	0.0	0.000	A
C-A	162	40			162				
A-B	129	32			129				
A-C	175	44			175				

2031 + Development, PM

Data Errors and Warnings

No errors or warnings

Junction Network

Junctions

Junction	Name	Junction type	Arm A Direction	Arm B Direction	Arm C Direction	Use circulating lanes	Junction Delay (s)	Junction LOS
1	untitled	T-Junction	Two-way	Two-way	Two-way		2.07	A

Junction Network

Driving side	Lighting	Network delay (s)	Network LOS
Left	Normal/unknown	2.07	A

Traffic Demand

Demand Set Details

ID	Scenario name	Time Period name	Traffic profile type	Start time (HH mm)	Finish time (HH mm)	Time segment length (min)	Run automatically
D4	2031 + Development	PM	ONE HOUR	16:45	18:15	15	✓

Vehicle mix varies over turn	Vehicle mix varies over entry	Vehicle mix source	PCU Factor for a HV (PCU)
✓	✓	HV Percentages	2.00

Demand overview (Traffic)

Arm	Linked arm	Profile type	Use O-D data	Average Demand (PCU/hr)	Scaling Factor (%)
A		ONE HOUR	✓	248	100.000
B		ONE HOUR	✓	102	100.000
C		ONE HOUR	✓	226	100.000

Origin-Destination Data

Demand (PCU/hr)

		To		
		A	B	C
From	A	0	42	206
	B	102	0	0
	C	226	0	0

Vehicle Mix

Heavy Vehicle Percentages

		To		
		A	B	C
From	A	0	0	1
	B	0	0	0
	C	3	0	0

Results

Results Summary for whole modelled period

Stream	Max RFC	Max Delay (s)	Max Queue (PCU)	Max LOS	Average Demand (PCU/hr)	Total Junction Arrivals (PCU)
B-AC	0.27	11.69	0.4	B	94	140
C-AB	0.00	0.00	0.0	A	0	0
C-A					207	311
A-B					39	58
A-C					189	284

Main Results for each time segment

16:45 - 17:00

Stream	Total Demand (PCU/hr)	Junction Arrivals (PCU)	Capacity (PCU/hr)	RFC	Throughput (PCU/hr)	Start queue (PCU)	End queue (PCU)	Delay (s)	Unsignalised level of service
B-AC	77	19	450	0.171	76	0.0	0.2	9.596	A
C-AB	0	0	640	0.000	0	0.0	0.0	0.000	A
C-A	170	43			170				
A-B	32	8			32				
A-C	155	39			155				

17:00 - 17:15

Stream	Total Demand (PCU/hr)	Junction Arrivals (PCU)	Capacity (PCU/hr)	RFC	Throughput (PCU/hr)	Start queue (PCU)	End queue (PCU)	Delay (s)	Unsignalised level of service
B-AC	92	23	438	0.209	91	0.2	0.3	10 388	B
C-AB	0	0	630	0.000	0	0.0	0.0	0.000	A
C-A	203	51			203				
A-B	38	9			38				
A-C	185	46			185				

17:15 - 17:30

Stream	Total Demand (PCU/hr)	Junction Arrivals (PCU)	Capacity (PCU/hr)	RFC	Throughput (PCU/hr)	Start queue (PCU)	End queue (PCU)	Delay (s)	Unsignalised level of service
B-AC	112	28	420	0.267	112	0.3	0.4	11 660	B
C-AB	0	0	617	0.000	0	0.0	0.0	0.000	A
C-A	249	62			249				
A-B	46	12			46				
A-C	227	57			227				

17:30 - 17:45

Stream	Total Demand (PCU/hr)	Junction Arrivals (PCU)	Capacity (PCU/hr)	RFC	Throughput (PCU/hr)	Start queue (PCU)	End queue (PCU)	Delay (s)	Unsignalised level of service
B-AC	112	28	420	0.267	112	0.4	0.4	11 690	B
C-AB	0	0	617	0.000	0	0.0	0.0	0.000	A
C-A	249	62			249				
A-B	46	12			46				
A-C	227	57			227				

17:45 - 18:00

Stream	Total Demand (PCU/hr)	Junction Arrivals (PCU)	Capacity (PCU/hr)	RFC	Throughput (PCU/hr)	Start queue (PCU)	End queue (PCU)	Delay (s)	Unsignalised level of service
B-AC	92	23	438	0.209	92	0.4	0.3	10.425	B
C-AB	0	0	630	0.000	0	0.0	0.0	0.000	A
C-A	203	51			203				
A-B	38	9			38				
A-C	185	46			185				

18:00 - 18:15

Stream	Total Demand (PCU/hr)	Junction Arrivals (PCU)	Capacity (PCU/hr)	RFC	Throughput (PCU/hr)	Start queue (PCU)	End queue (PCU)	Delay (s)	Unsignalised level of service
B-AC	77	19	450	0.171	77	0.3	0.2	9.650	A
C-AB	0	0	640	0.000	0	0.0	0.0	0.000	A
C-A	170	43			170				
A-B	32	8			32				
A-C	155	39			155				

T19562
Heyford Park



Appendix L

Junctions 10 Output – Camp Road/Somerton Road

Junctions 10
PICADY 10 - Priority Intersection Module
Version: 10 0.2.1576 © Copyright TRL Software Limited, 2021
For sales and distribution information, program advice and maintenance, contact TRL Software: +44 (0)1344 379777 software@trl.co.uk trlsoftware.com
The users of this computer program for the solution of an engineering problem are in no way relieved of their responsibility for the correctness of the solution

Filename: T19562 - Camp Rd-Somerton Rd.j10

Path: C:\Users\MaxLaw\Hub Transport Planning Ltd\Hub Transport Planning - General\Projects\T19562 Heyford Park\Junction Assessments\Picady

Report generation date: 02/12/2021 11:57:32

- »2031 Reference Case, AM
- »2031 Reference Case, PM
- »2031 + Development, AM
- »2031 + Development, PM

Summary of junction performance

	AM					PM				
	Set ID	Queue (PCU)	Delay (s)	RFC	LOS	Set ID	Queue (PCU)	Delay (s)	RFC	LOS
2031 Reference Case										
Stream B-AC	D1	0.9	13.84	0.48	B	D2	0.7	11.54	0.41	B
Stream C-AB		0.2	7.04	0.13	A		0.2	6.30	0.12	A
2031 + Development										
Stream B-AC	D3	1.0	14.77	0.51	B	D4	0.7	11.98	0.43	B
Stream C-AB		0.2	7.09	0.13	A		0.2	6.40	0.13	A

Values shown are the highest values encountered over all time segments. Delay is the maximum value of average delay per arriving vehicle.

File summary

File Description

Title	Camp Road/Somerton Road
Location	Heyford Park
Site number	
Date	22/11/2021
Version	
Status	(new file)
Identifier	
Client	Richborough Estates
Jobnumber	T19562
Enumerator	HUBTRANSPORTPLANNING\MaxLaw
Description	

Units

Distance units	Speed units	Traffic units input	Traffic units results	Flow units	Average delay units	Total delay units	Rate of delay units
m	kph	PCU	PCU	perHour	s	-Min	perMin

Analysis Options

Vehicle length (m)	Calculate Queue Percentiles	Calculate detailed queueing delay	Show lane queues in feet / metres	Show all PICADY stream intercepts	Calculate residual capacity	RFC Threshold	Average Delay threshold (s)	Queue threshold (PCU)	Use iterations with HCM roundabouts	Max number of iterations for roundabouts
5.75						0.85	36.00	20.00		500

Demand Set Summary

ID	Scenario name	Time Period name	Traffic profile type	Start time (HH mm)	Finish time (HH mm)	Time segment length (min)	Run automatically
D1	2031 Reference Case	AM	ONE HOUR	07:45	09:15	15	✓
D2	2031 Reference Case	PM	ONE HOUR	16:45	18:15	15	✓
D3	2031 + Development	AM	ONE HOUR	07:45	09:15	15	✓
D4	2031 + Development	PM	ONE HOUR	16:45	18:15	15	✓

Analysis Set Details

ID	Include in report	Network flow scaling factor (%)	Network capacity scaling factor (%)
A1	✓	100.000	100.000

2031 Reference Case, AM

Data Errors and Warnings

No errors or warnings

Junction Network

Junctions

Junction	Name	Junction type	Arm A Direction	Arm B Direction	Arm C Direction	Use circulating lanes	Junction Delay (s)	Junction LOS
1	untitled	T-Junction	Two-way	Two-way	Two-way		6.04	A

Junction Network

Driving side	Lighting	Network delay (s)	Network LOS
Left	Normal/unknown	6.04	A

Arms

Arms

Arm	Name	Description	Arm type
A	untitled		Major
B	untitled		Minor
C	untitled		Major

Major Arm Geometry

Arm	Width of carriageway (m)	Has kerbed central reserve	Has right-turn storage	Visibility for right turn (m)	Blocks?	Blocking queue (PCU)
C	6.00			135.0	✓	0.00

Geometries for Arm C are measured opposite Arm B. Geometries for Arm A (if relevant) are measured opposite Arm D.

Minor Arm Geometry

Arm	Minor arm type	Lane width (m)	Visibility to left (m)	Visibility to right (m)
B	One lane	3.70	23	23

Slope / Intercept / Capacity

Priority Intersection Slopes and Intercepts

Stream	Intercept (PCU/hr)	Slope for A-B	Slope for A-C	Slope for C-A	Slope for C-B
B-A	531	0.097	0.245	0.154	0.349
B-C	683	0.105	0.265	-	-
C-B	652	0.253	0.253	-	-

The slopes and intercepts shown above include custom intercept adjustments only.

Streams may be combined, in which case capacity will be adjusted.

Values are shown for the first time segment only; they may differ for subsequent time segments.

Traffic Demand

Demand Set Details

ID	Scenario name	Time Period name	Traffic profile type	Start time (HH mm)	Finish time (HH mm)	Time segment length (min)	Run automatically
D1	2031 Reference Case	AM	ONE HOUR	07:45	09:15	15	✓

Vehicle mix varies over turn	Vehicle mix varies over entry	Vehicle mix source	PCU Factor for a HV (PCU)
✓	✓	HV Percentages	2.00

Demand overview (Traffic)

Arm	Linked arm	Profile type	Use O-D data	Average Demand (PCU/hr)	Scaling Factor (%)
A		ONE HOUR	✓	252	100.000
B		ONE HOUR	✓	219	100.000
C		ONE HOUR	✓	114	100.000

Origin-Destination Data

Demand (PCU/hr)

		To		
		A	B	C
From	A	0	145	107
	B	141	0	78
	C	48	66	0

Vehicle Mix

Heavy Vehicle Percentages

		To		
		A	B	C
From	A	0	0	3
	B	0	0	4
	C	8	5	0

Results

Results Summary for whole modelled period

Stream	Max RFC	Max Delay (s)	Max Queue (PCU)	Max LOS	Average Demand (PCU/hr)	Total Junction Arrivals (PCU)
B-AC	0.48	13.84	0.9	B	201	301
C-AB	0.13	7.04	0.2	A	65	98
C-A					39	59
A-B					133	200
A-C					98	147

Main Results for each time segment

07:45 - 08:00

Stream	Total Demand (PCU/hr)	Junction Arrivals (PCU)	Capacity (PCU/hr)	RFC	Throughput (PCU/hr)	Start queue (PCU)	End queue (PCU)	Delay (s)	Unsignalised level of service
B-AC	165	41	528	0.312	163	0.0	0.5	9.960	A
C-AB	53	13	628	0.084	52	0.0	0.1	6.570	A
C-A	33	8			33				
A-B	109	27			109				
A-C	81	20			81				

08:00 - 08:15

Stream	Total Demand (PCU/hr)	Junction Arrivals (PCU)	Capacity (PCU/hr)	RFC	Throughput (PCU/hr)	Start queue (PCU)	End queue (PCU)	Delay (s)	Unsignalised level of service
B-AC	197	49	518	0.380	196	0.5	0.6	11 318	B
C-AB	64	16	624	0.102	64	0.1	0.1	6.760	A
C-A	39	10			39				
A-B	130	33			130				
A-C	96	24			96				

08:15 - 08:30

Stream	Total Demand (PCU/hr)	Junction Arrivals (PCU)	Capacity (PCU/hr)	RFC	Throughput (PCU/hr)	Start queue (PCU)	End queue (PCU)	Delay (s)	Unsignalised level of service
B-AC	241	60	505	0.478	240	0.6	0.9	13.721	B
C-AB	80	20	618	0.129	79	0.1	0.2	7.033	A
C-A	46	12			46				
A-B	160	40			160				
A-C	118	29			118				

08:30 - 08:45

Stream	Total Demand (PCU/hr)	Junction Arrivals (PCU)	Capacity (PCU/hr)	RFC	Throughput (PCU/hr)	Start queue (PCU)	End queue (PCU)	Delay (s)	Unsignalised level of service
B-AC	241	60	505	0.478	241	0.9	0.9	13 840	B
C-AB	80	20	618	0.129	80	0.2	0.2	7.041	A
C-A	46	11			46				
A-B	160	40			160				
A-C	118	29			118				

08:45 - 09:00

Stream	Total Demand (PCU/hr)	Junction Arrivals (PCU)	Capacity (PCU/hr)	RFC	Throughput (PCU/hr)	Start queue (PCU)	End queue (PCU)	Delay (s)	Unsignalised level of service
B-AC	197	49	518	0.380	198	0.9	0.6	11.447	B
C-AB	64	16	624	0.102	64	0.2	0.1	6.768	A
C-A	39	10			39				
A-B	130	33			130				
A-C	96	24			96				

09:00 - 09:15

Stream	Total Demand (PCU/hr)	Junction Arrivals (PCU)	Capacity (PCU/hr)	RFC	Throughput (PCU/hr)	Start queue (PCU)	End queue (PCU)	Delay (s)	Unsignalised level of service
B-AC	165	41	528	0.312	166	0.6	0.5	10 099	B
C-AB	53	13	628	0.084	53	0.1	0.1	6.585	A
C-A	33	8			33				
A-B	109	27			109				
A-C	81	20			81				

2031 Reference Case, PM

Data Errors and Warnings

No errors or warnings

Junction Network

Junctions

Junction	Name	Junction type	Arm A Direction	Arm B Direction	Arm C Direction	Use circulating lanes	Junction Delay (s)	Junction LOS
1	untitled	T-Junction	Two-way	Two-way	Two-way		4.82	A

Junction Network

Driving side	Lighting	Network delay (s)	Network LOS
Left	Normal/unknown	4.82	A

Traffic Demand

Demand Set Details

ID	Scenario name	Time Period name	Traffic profile type	Start time (HH mm)	Finish time (HH mm)	Time segment length (min)	Run automatically
D2	2031 Reference Case	PM	ONE HOUR	16:45	18:15	15	✓

Vehicle mix varies over turn	Vehicle mix varies over entry	Vehicle mix source	PCU Factor for a HV (PCU)
✓	✓	HV Percentages	2.00

Demand overview (Traffic)

Arm	Linked arm	Profile type	Use O-D data	Average Demand (PCU/hr)	Scaling Factor (%)
A		ONE HOUR	✓	201	100.000
B		ONE HOUR	✓	198	100.000
C		ONE HOUR	✓	166	100.000

Origin-Destination Data

Demand (PCU/hr)

		To		
		A	B	C
From	A	0	153	48
	B	105	0	93
	C	107	59	0

Vehicle Mix

Heavy Vehicle Percentages

		To		
		A	B	C
From	A	0	2	0
	B	0	0	3
	C	1	5	0

Results

Results Summary for whole modelled period

Stream	Max RFC	Max Delay (s)	Max Queue (PCU)	Max LOS	Average Demand (PCU/hr)	Total Junction Arrivals (PCU)
B-AC	0.41	11.54	0.7	B	182	273
C-AB	0.12	6.30	0.2	A	64	96
C-A					89	133
A-B					140	211
A-C					44	66

Main Results for each time segment

16:45 - 17:00

Stream	Total Demand (PCU/hr)	Junction Arrivals (PCU)	Capacity (PCU/hr)	RFC	Throughput (PCU/hr)	Start queue (PCU)	End queue (PCU)	Delay (s)	Unsignalised level of service
B-AC	149	37	553	0.269	148	0.0	0.4	8.965	A
C-AB	51	13	667	0.076	50	0.0	0.1	6.097	A
C-A	74	19			74				
A-B	115	29			115				
A-C	36	9			36				

17:00 - 17:15

Stream	Total Demand (PCU/hr)	Junction Arrivals (PCU)	Capacity (PCU/hr)	RFC	Throughput (PCU/hr)	Start queue (PCU)	End queue (PCU)	Delay (s)	Unsignalised level of service
B-AC	178	44	545	0.326	178	0.4	0.5	9.910	A
C-AB	62	15	670	0.092	62	0.1	0.1	6.180	A
C-A	87	22			87				
A-B	138	34			138				
A-C	43	11			43				

17:15 - 17:30

Stream	Total Demand (PCU/hr)	Junction Arrivals (PCU)	Capacity (PCU/hr)	RFC	Throughput (PCU/hr)	Start queue (PCU)	End queue (PCU)	Delay (s)	Unsignalised level of service
B-AC	218	55	534	0.408	217	0.5	0.7	11.477	B
C-AB	79	20	675	0.117	79	0.1	0.2	6.298	A
C-A	104	26			104				
A-B	168	42			168				
A-C	53	13			53				

17:30 - 17:45

Stream	Total Demand (PCU/hr)	Junction Arrivals (PCU)	Capacity (PCU/hr)	RFC	Throughput (PCU/hr)	Start queue (PCU)	End queue (PCU)	Delay (s)	Unsignalised level of service
B-AC	218	55	534	0.408	218	0.7	0.7	11.535	B
C-AB	79	20	675	0.117	79	0.2	0.2	6.299	A
C-A	104	26			104				
A-B	168	42			168				
A-C	53	13			53				

17:45 - 18:00

Stream	Total Demand (PCU/hr)	Junction Arrivals (PCU)	Capacity (PCU/hr)	RFC	Throughput (PCU/hr)	Start queue (PCU)	End queue (PCU)	Delay (s)	Unsignalised level of service
B-AC	178	44	545	0.326	179	0.7	0.5	9.981	A
C-AB	62	16	670	0.093	62	0.2	0.1	6.180	A
C-A	87	22			87				
A-B	138	34			138				
A-C	43	11			43				

18:00 - 18:15

Stream	Total Demand (PCU/hr)	Junction Arrivals (PCU)	Capacity (PCU/hr)	RFC	Throughput (PCU/hr)	Start queue (PCU)	End queue (PCU)	Delay (s)	Unsignalised level of service
B-AC	149	37	553	0.269	150	0.5	0.4	9.053	A
C-AB	51	13	667	0.076	51	0.1	0.1	6.104	A
C-A	74	19			74				
A-B	115	29			115				
A-C	36	9			36				

2031 + Development, AM

Data Errors and Warnings

No errors or warnings

Junction Network

Junctions

Junction	Name	Junction type	Arm A Direction	Arm B Direction	Arm C Direction	Use circulating lanes	Junction Delay (s)	Junction LOS
1	untitled	T-Junction	Two-way	Two-way	Two-way		6.53	A

Junction Network

Driving side	Lighting	Network delay (s)	Network LOS
Left	Normal/unknown	6.53	A

Traffic Demand

Demand Set Details

ID	Scenario name	Time Period name	Traffic profile type	Start time (HH mm)	Finish time (HH mm)	Time segment length (min)	Run automatically
D3	2031 + Development	AM	ONE HOUR	07:45	09:15	15	✓

Vehicle mix varies over turn	Vehicle mix varies over entry	Vehicle mix source	PCU Factor for a HV (PCU)
✓	✓	HV Percentages	2.00

Demand overview (Traffic)

Arm	Linked arm	Profile type	Use O-D data	Average Demand (PCU/hr)	Scaling Factor (%)
A		ONE HOUR	✓	258	100.000
B		ONE HOUR	✓	232	100.000
C		ONE HOUR	✓	112	100.000

Origin-Destination Data

Demand (PCU/hr)

		To		
		A	B	C
From	A	0	149	109
	B	152	0	80
	C	46	66	0

Vehicle Mix

Heavy Vehicle Percentages

		To		
		A	B	C
From	A	0	0	3
	B	0	0	4
	C	11	5	0

Results

Results Summary for whole modelled period

Stream	Max RFC	Max Delay (s)	Max Queue (PCU)	Max LOS	Average Demand (PCU/hr)	Total Junction Arrivals (PCU)
B-AC	0.51	14.77	1.0	B	213	319
C-AB	0.13	7.09	0.2	A	65	98
C-A					38	56
A-B					137	205
A-C					100	150

Main Results for each time segment

07:45 - 08:00

Stream	Total Demand (PCU/hr)	Junction Arrivals (PCU)	Capacity (PCU/hr)	RFC	Throughput (PCU/hr)	Start queue (PCU)	End queue (PCU)	Delay (s)	Unsignalised level of service
B-AC	175	44	526	0.332	173	0.0	0.5	10 283	B
C-AB	53	13	626	0.084	52	0.0	0.1	6.602	A
C-A	32	8			32				
A-B	112	28			112				
A-C	82	21			82				

08:00 - 08:15

Stream	Total Demand (PCU/hr)	Junction Arrivals (PCU)	Capacity (PCU/hr)	RFC	Throughput (PCU/hr)	Start queue (PCU)	End queue (PCU)	Delay (s)	Unsignalised level of service
B-AC	209	52	516	0.404	208	0.5	0.7	11 821	B
C-AB	64	16	621	0.102	63	0.1	0.1	6.799	A
C-A	37	9			37				
A-B	134	33			134				
A-C	98	24			98				

08:15 - 08:30

Stream	Total Demand (PCU/hr)	Junction Arrivals (PCU)	Capacity (PCU/hr)	RFC	Throughput (PCU/hr)	Start queue (PCU)	End queue (PCU)	Delay (s)	Unsignalised level of service
B-AC	255	64	502	0.509	254	0.7	1.0	14 621	B
C-AB	79	20	615	0.129	79	0.1	0.2	7.084	A
C-A	44	11			44				
A-B	164	41			164				
A-C	120	30			120				

08:30 - 08:45

Stream	Total Demand (PCU/hr)	Junction Arrivals (PCU)	Capacity (PCU/hr)	RFC	Throughput (PCU/hr)	Start queue (PCU)	End queue (PCU)	Delay (s)	Unsignalised level of service
B-AC	255	64	502	0.509	255	1.0	1.0	14.773	B
C-AB	79	20	615	0.129	79	0.2	0.2	7.091	A
C-A	44	11			44				
A-B	164	41			164				
A-C	120	30			120				

08:45 - 09:00

Stream	Total Demand (PCU/hr)	Junction Arrivals (PCU)	Capacity (PCU/hr)	RFC	Throughput (PCU/hr)	Start queue (PCU)	End queue (PCU)	Delay (s)	Unsignalised level of service
B-AC	209	52	516	0.404	210	1.0	0.7	11 985	B
C-AB	64	16	621	0.102	64	0.2	0.1	6.812	A
C-A	37	9			37				
A-B	134	33			134				
A-C	98	24			98				

09:00 - 09:15

Stream	Total Demand (PCU/hr)	Junction Arrivals (PCU)	Capacity (PCU/hr)	RFC	Throughput (PCU/hr)	Start queue (PCU)	End queue (PCU)	Delay (s)	Unsignalised level of service
B-AC	175	44	525	0.332	175	0.7	0.5	10.448	B
C-AB	53	13	626	0.084	53	0.1	0.1	6.618	A
C-A	32	8			32				
A-B	112	28			112				
A-C	82	21			82				

2031 + Development, PM

Data Errors and Warnings

No errors or warnings

Junction Network

Junctions

Junction	Name	Junction type	Arm A Direction	Arm B Direction	Arm C Direction	Use circulating lanes	Junction Delay (s)	Junction LOS
1	untitled	T-Junction	Two-way	Two-way	Two-way		5.03	A

Junction Network

Driving side	Lighting	Network delay (s)	Network LOS
Left	Normal/unknown	5.03	A

Traffic Demand

Demand Set Details

ID	Scenario name	Time Period name	Traffic profile type	Start time (HH mm)	Finish time (HH mm)	Time segment length (min)	Run automatically
D4	2031 + Development	PM	ONE HOUR	16:45	18:15	15	✓

Vehicle mix varies over turn	Vehicle mix varies over entry	Vehicle mix source	PCU Factor for a HV (PCU)
✓	✓	HV Percentages	2.00

Demand overview (Traffic)

Arm	Linked arm	Profile type	Use O-D data	Average Demand (PCU/hr)	Scaling Factor (%)
A		ONE HOUR	✓	210	100.000
B		ONE HOUR	✓	206	100.000
C		ONE HOUR	✓	170	100.000

Origin-Destination Data

Demand (PCU/hr)

		To		
		A	B	C
From	A	0	162	48
	B	110	0	96
	C	106	64	0

Vehicle Mix

Heavy Vehicle Percentages

		To		
		A	B	C
From	A	0	2	0
	B	0	0	3
	C	1	5	0

Results

Results Summary for whole modelled period

Stream	Max RFC	Max Delay (s)	Max Queue (PCU)	Max LOS	Average Demand (PCU/hr)	Total Junction Arrivals (PCU)
B-AC	0.43	11.98	0.7	B	189	284
C-AB	0.13	6.40	0.2	A	69	104
C-A					87	130
A-B					149	223
A-C					44	66

Main Results for each time segment

16:45 - 17:00

Stream	Total Demand (PCU/hr)	Junction Arrivals (PCU)	Capacity (PCU/hr)	RFC	Throughput (PCU/hr)	Start queue (PCU)	End queue (PCU)	Delay (s)	Unsignalised level of service
B-AC	155	39	551	0.281	154	0.0	0.4	9.144	A
C-AB	55	14	665	0.082	54	0.0	0.1	6.158	A
C-A	73	18			73				
A-B	122	30			122				
A-C	36	9			36				

17:00 - 17:15

Stream	Total Demand (PCU/hr)	Junction Arrivals (PCU)	Capacity (PCU/hr)	RFC	Throughput (PCU/hr)	Start queue (PCU)	End queue (PCU)	Delay (s)	Unsignalised level of service
B-AC	185	46	543	0.341	185	0.4	0.5	10.175	B
C-AB	67	17	668	0.101	67	0.1	0.1	6.260	A
C-A	86	21			86				
A-B	146	36			146				
A-C	43	11			43				

17:15 - 17:30

Stream	Total Demand (PCU/hr)	Junction Arrivals (PCU)	Capacity (PCU/hr)	RFC	Throughput (PCU/hr)	Start queue (PCU)	End queue (PCU)	Delay (s)	Unsignalised level of service
B-AC	227	57	531	0.427	226	0.5	0.7	11.910	B
C-AB	85	21	672	0.127	85	0.1	0.2	6.402	A
C-A	102	25			102				
A-B	178	45			178				
A-C	53	13			53				

17:30 - 17:45

Stream	Total Demand (PCU/hr)	Junction Arrivals (PCU)	Capacity (PCU/hr)	RFC	Throughput (PCU/hr)	Start queue (PCU)	End queue (PCU)	Delay (s)	Unsignalised level of service
B-AC	227	57	531	0.427	227	0.7	0.7	11.977	B
C-AB	85	21	672	0.127	85	0.2	0.2	6.403	A
C-A	102	25			102				
A-B	178	45			178				
A-C	53	13			53				

17:45 - 18:00

Stream	Total Demand (PCU/hr)	Junction Arrivals (PCU)	Capacity (PCU/hr)	RFC	Throughput (PCU/hr)	Start queue (PCU)	End queue (PCU)	Delay (s)	Unsignalised level of service
B-AC	185	46	543	0.341	186	0.7	0.5	10 254	B
C-AB	67	17	668	0.101	67	0.2	0.1	6.258	A
C-A	86	21			86				
A-B	146	36			146				
A-C	43	11			43				

18:00 - 18:15

Stream	Total Demand (PCU/hr)	Junction Arrivals (PCU)	Capacity (PCU/hr)	RFC	Throughput (PCU/hr)	Start queue (PCU)	End queue (PCU)	Delay (s)	Unsignalised level of service
B-AC	155	39	551	0.281	156	0.5	0.4	9.242	A
C-AB	55	14	665	0.082	55	0.1	0.1	6.165	A
C-A	73	18			73				
A-B	122	30			122				
A-C	36	9			36				

T19562
Heyford Park



Appendix M

Junctions 10 Output – A4260/Somerton Road/N Aston Road

Junctions 10
PICADY 10 - Priority Intersection Module
Version: 10.0.2.1574 © Copyright TRL Software Limited, 2021
For sales and distribution information, program advice and maintenance, contact TRL Software: +44 (0)1344 379777 software@trl.co.uk trlsoftware.com
The users of this computer program for the solution of an engineering problem are in no way relieved of their responsibility for the correctness of the solution

Filename: T19562 - A4260-Somerton Rd-N Aston Rd - Crossroads.j10
Path: C:\Users\JamesParker\Hub Transport Planning Ltd\Hub Transport Planning - General\Projects\T19562 Heyford Park\Junction Assessments\Picady
Report generation date: 17/12/2021 14:46:14

- »2031 Reference Case, AM
- »2031 Reference Case, PM
- »2031 + Development, AM
- »2031 + Development, PM

Summary of junction performance

	AM					PM				
	Set ID	Queue (PCU)	Delay (s)	RFC	LOS	Set ID	Queue (PCU)	Delay (s)	RFC	LOS
2031 Reference Case										
Stream B-CD	D1	0.3	25.63	0.24	D	D2	0.3	35.22	0.23	E
Stream B-AD		0.3	27.89	0.25	D		0.3	34.51	0.24	D
Stream A-BCD		0.1	13.09	0.08	B		0.0	6.86	0.03	A
Stream D-AB		12.5	606.21	1.43	F		0.2	22.66	0.20	C
Stream D-BC		11.2	597.11	1.41	F		0.9	41.05	0.50	E
Stream C-ABD		0.0	5.96	0.00	A		0.0	9.12	0.02	A
2031 + Development										
Stream B-CD	D3	0.3	25.92	0.24	D	D4	0.3	36.63	0.24	E
Stream B-AD		0.3	28.26	0.25	D		0.3	35.65	0.26	E
Stream A-BCD		0.1	13.07	0.08	B		0.0	6.90	0.03	A
Stream D-AB		14.3	693.64	1.56	F		0.3	24.01	0.21	C
Stream D-BC		13.9	677.53	1.54	F		1.0	43.24	0.52	E
Stream C-ABD		0.0	5.96	0.00	A		0.0	9.14	0.02	A

Values shown are the highest values encountered over all time segments. Delay is the maximum value of average delay per arriving vehicle.

File summary

File Description

Title	A4280/Somerton Road/N Aston Road
Location	Heyford Park
Site number	
Date	25/11/2021
Version	
Status	(new file)
Identifier	
Client	Richborough Estates
Jobnumber	T19562
Enumerator	HUBTRANSPORTPLANNING\MaxLaw
Description	

Units

Distance units	Speed units	Traffic units input	Traffic units results	Flow units	Average delay units	Total delay units	Rate of delay units
m	kph	PCU	PCU	perHour	s	-Min	perMin

Analysis Options

Vehicle length (m)	Calculate Queue Percentiles	Calculate detailed queueing delay	Show lane queues in feet / metres	Show all PICADY stream intercepts	Calculate residual capacity	RFC Threshold	Average Delay threshold (s)	Queue threshold (PCU)	Use iterations with HCM roundabouts	Max number of iterations for roundabouts
5.75						0.85	38.00	20.00		500

Demand Set Summary

ID	Scenario name	Time Period name	Traffic profile type	Start time (HH:mm)	Finish time (HH:mm)	Time segment length (min)	Run automatically
D1	2031 Reference Case	AM	ONE HOUR	07:45	09:15	15	✓
D2	2031 Reference Case	PM	ONE HOUR	16:45	18:15	15	✓
D3	2031 + Development	AM	ONE HOUR	07:45	09:15	15	✓
D4	2031 + Development	PM	ONE HOUR	16:45	18:15	15	✓

Analysis Set Details

ID	Include in report	Network flow scaling factor (%)	Network capacity scaling factor (%)
A1	✓	100.000	100.000

2031 Reference Case, AM

Data Errors and Warnings

No errors or warnings

Junction Network

Junctions

Junction	Name	Junction type	Arm A Direction	Arm B Direction	Arm C Direction	Arm D Direction	Use circulating lanes	Junction Delay (s)	Junction LOS
1	untitled	Crossroads	Two-way	Two-way	Two-way	Two-way		34.98	D

Junction Network

Driving side	Lighting	Network delay (s)	Network LOS
Left	Normal/unknown	34.98	D

Arms

Arms

Arm	Name	Description	Arm type
A	A4280 (S)		Major
B	N Aston Road		Minor
C	A4280 (N)		Major
D	Somerton Road		Minor

Major Arm Geometry

Arm	Width of carriageway (m)	Has kerbed central reserve	Has right-turn storage	Width for right-turn storage (m)	Visibility for right turn (m)	Blocks?	Blocking queue (PCU)
A	6.50		✓	3.00	175.0	✓	10.00
C	6.50		✓	3.00	250.0	✓	14.00

Geometries for Arm C are measured opposite Arm B. Geometries for Arm A (if relevant) are measured opposite Arm D.

Minor Arm Geometry

Arm	Minor arm type	Width at give-way (m)	Width at 5m (m)	Width at 10m (m)	Width at 15m (m)	Width at 20m (m)	Estimate flare length	Flare length (PCU)	Visibility to left (m)	Visibility to right (m)
B	One lane plus flare	10.00	4.50	3.00	2.50	2.50		0.50	130	116
D	One lane plus flare	10.00	4.00	2.75	2.75	2.75		0.50	30	41

Slope / Intercept / Capacity

Priority Intersection Slopes and Intercepts

Stream	Intercept (PCU/hr)	Slope for A-B	Slope for A-C	Slope for A-D	Slope for B-A	Slope for B-C	Slope for B-D	Slope for C-A	Slope for C-B	Slope for C-D	Slope for D-A	Slope for D-B	Slope for D-C
A-D	734	-	-	-	-	-	-	0.278	0.397	0.278	-	-	-
B-A	616	0.110	0.277	0.277	-	-	-	0.175	0.396	-	0.277	0.277	0.139
B-C	741	0.111	0.281	-	-	-	-	-	-	-	-	-	-
B-D, nearside lane	616	0.110	0.277	0.277	-	-	-	0.175	0.396	0.175	-	-	-
B-D, offside lane	616	0.110	0.277	0.277	-	-	-	0.175	0.396	0.175	-	-	-
C-B	781	0.296	0.296	0.423	-	-	-	-	-	-	-	-	-
D-A	780	-	-	-	-	-	-	0.296	-	0.117	-	-	-
D-B, nearside lane	609	0.173	0.173	0.392	-	-	-	0.274	0.274	0.109	-	-	-
D-B, offside lane	530	0.150	0.150	0.341	-	-	-	0.239	0.239	0.095	-	-	-
D-C	530	-	0.150	0.341	0.119	0.239	0.239	0.239	0.239	0.095	-	-	-

The slopes and intercepts shown above include custom intercept adjustments only.

Streams may be combined, in which case capacity will be adjusted.

Values are shown for the first time segment only; they may differ for subsequent time segments.

Traffic Demand

Demand Set Details

ID	Scenario name	Time Period name	Traffic profile type	Start time (HH:mm)	Finish time (HH:mm)	Time segment length (min)	Run automatically
D1	2031 Reference Case	AM	ONE HOUR	07:45	09:15	15	✓

Vehicle mix varies over turn	Vehicle mix varies over entry	Vehicle mix source	PCU Factor for a HV (PCU)
✓	✓	HV Percentages	2.00

Demand overview (Traffic)

Arm	Linked arm	Profile type	Use O-D data	Average Demand (PCU/hr)	Scaling Factor (%)
A		ONE HOUR	✓	530	100.000
B		ONE HOUR	✓	78	100.000
C		ONE HOUR	✓	1419	100.000
D		ONE HOUR	✓	121	100.000

Origin-Destination Data

Demand (PCU/hr)

		To			
		A	B	C	D
From	A	0	10	498	22
	B	9	0	6	63
	C	1308	1	0	110
	D	25	39	57	0

Vehicle Mix

Heavy Vehicle Percentages

		To			
		A	B	C	D
From	A	0	0	2	0
	B	0	0	0	0
	C	8	0	0	0
	D	0	0	0	0

Results

Results Summary for whole modelled period

Stream	Max RFC	Max Delay (s)	Max Queue (PCU)	Max LOS	Average Demand (PCU/hr)	Total Junction Arrivals (PCU)
B-CD	0.24	25.63	0.3	D	36	53
B-AD	0.25	27.89	0.3	D	36	54
A-BCD	0.08	13.09	0.1	B	20	30
A-B					9	14
A-C					457	685
D-AB	1.43	606.21	12.5	F	52	78
D-BC	1.41	597.11	11.2	F	59	89
C-ABD	0.00	5.96	0.0	A	0.92	1
C-D					101	151
C-A					1200	1800

2031 Reference Case, PM

Data Errors and Warnings

No errors or warnings

Junction Network

Junctions

Junction	Name	Junction type	Arm A Direction	Arm B Direction	Arm C Direction	Arm D Direction	Use circulating lanes	Junction Delay (s)	Junction LOS
1	untitled	Crossroads	Two-way	Two-way	Two-way	Two-way		3.18	A

Junction Network

Driving side	Lighting	Network delay (s)	Network LOS
Left	Normal/unknown	3.18	A

Traffic Demand

Demand Set Details

ID	Scenario name	Time Period name	Traffic profile type	Start time (HH:mm)	Finish time (HH:mm)	Time segment length (min)	Run automatically
D2	2031 Reference Case	PM	ONE HOUR	16:45	18:15	15	✓

Vehicle mix varies over turn	Vehicle mix varies over entry	Vehicle mix source	PCU Factor for a HV (PCU)
✓	✓	HV Percentages	2.00

Demand overview (Traffic)

Arm	Linked arm	Profile type	Use O-D data	Average Demand (PCU/hr)	Scaling Factor (%)
A		ONE HOUR	✓	1159	100.000
B		ONE HOUR	✓	58	100.000
C		ONE HOUR	✓	630	100.000
D		ONE HOUR	✓	114	100.000

Origin-Destination Data

Demand (PCU/hr)

		To			
		A	B	C	D
From	A	0	22	1123	14
	B	7	0	1	50
	C	501	6	0	123
	D	12	33	69	0

Vehicle Mix

Heavy Vehicle Percentages

		To			
		A	B	C	D
From	A	0	0	1	0
	B	0	0	0	0
	C	1	0	0	0
	D	0	0	0	0

Results

Results Summary for whole modelled period

Stream	Max RFC	Max Delay (s)	Max Queue (PCU)	Max LOS	Average Demand (PCU/hr)	Total Junction Arrivals (PCU)
B-CD	0.23	35.22	0.3	E	25	37
B-AD	0.24	34.51	0.3	D	29	43
A-BCD	0.03	6.86	0.0	A	13	19
A-B					20	30
A-C					1030	1546
D-AB	0.20	22.66	0.2	C	31	46
D-BC	0.50	41.05	0.9	E	74	111
C-ABD	0.02	9.12	0.0	A	6	8
C-D					113	169
C-A					460	690

2031 + Development, AM

Data Errors and Warnings

No errors or warnings

Junction Network

Junctions

Junction	Name	Junction type	Arm A Direction	Arm B Direction	Arm C Direction	Arm D Direction	Use circulating lanes	Junction Delay (s)	Junction LOS
1	untitled	Crossroads	Two-way	Two-way	Two-way	Two-way		41.79	E

Junction Network

Driving side	Lighting	Network delay (s)	Network LOS
Left	Normal/unknown	41.79	E

Traffic Demand

Demand Set Details

ID	Scenario name	Time Period name	Traffic profile type	Start time (HH:mm)	Finish time (HH:mm)	Time segment length (min)	Run automatically
D3	2031 + Development	AM	ONE HOUR	07:45	09:15	15	✓

Vehicle mix varies over turn	Vehicle mix varies over entry	Vehicle mix source	PCU Factor for a HV (PCU)
✓	✓	HV Percentages	2.00

Demand overview (Traffic)

Arm	Linked arm	Profile type	Use O-D data	Average Demand (PCU/hr)	Scaling Factor (%)
A		ONE HOUR	✓	531	100.000
B		ONE HOUR	✓	79	100.000
C		ONE HOUR	✓	1418	100.000
D		ONE HOUR	✓	128	100.000

Origin-Destination Data

Demand (PCU/hr)

		To			
		A	B	C	D
From	A	0	10	499	22
	B	9	0	6	64
	C	1309	1	0	108
	D	24	41	63	0

Vehicle Mix

Heavy Vehicle Percentages

		To			
		A	B	C	D
From	A	0	0	2	0
	B	0	0	0	0
	C	6	0	0	0
	D	0	0	0	0

Results

Results Summary for whole modelled period

Stream	Max RFC	Max Delay (s)	Max Queue (PCU)	Max LOS	Average Demand (PCU/hr)	Total Junction Arrivals (PCU)
B-CD	0.24	25.92	0.3	D	36	54
B-AD	0.25	28.28	0.3	D	36	55
A-BCD	0.08	13.07	0.1	B	20	30
A-B					9	14
A-C					458	687
D-AB	1.56	693.64	14.3	F	53	80
D-BC	1.54	677.53	13.9	F	64	96
C-ABD	0.00	5.96	0.0	A	0.92	1
C-D					99	149
C-A					1201	1802

2031 + Development, PM

Data Errors and Warnings

No errors or warnings

Junction Network

Junctions

Junction	Name	Junction type	Arm A Direction	Arm B Direction	Arm C Direction	Arm D Direction	Use circulating lanes	Junction Delay (s)	Junction LOS
1	untitled	Crossroads	Two-way	Two-way	Two-way	Two-way		3.40	A

Junction Network

Driving side	Lighting	Network delay (s)	Network LOS
Left	Normal/unknown	3.40	A

Traffic Demand

Demand Set Details

ID	Scenario name	Time Period name	Traffic profile type	Start time (HH:mm)	Finish time (HH:mm)	Time segment length (min)	Run automatically
D4	2031 + Development	PM	ONE HOUR	16:45	18:15	15	✓

Vehicle mix varies over turn	Vehicle mix varies over entry	Vehicle mix source	PCU Factor for a HV (PCU)
✓	✓	HV Percentages	2.00

Demand overview (Traffic)

Arm	Linked arm	Profile type	Use O-D data	Average Demand (PCU/hr)	Scaling Factor (%)
A		ONE HOUR	✓	1161	100.000
B		ONE HOUR	✓	60	100.000
C		ONE HOUR	✓	636	100.000
D		ONE HOUR	✓	117	100.000

Origin-Destination Data

Demand (PCU/hr)

		To			
		A	B	C	D
From	A	0	22	1124	15
	B	7	0	1	52
	C	501	6	0	129
	D	12	34	71	0

Vehicle Mix

Heavy Vehicle Percentages

		To			
		A	B	C	D
From	A	0	0	1	0
	B	0	0	0	0
	C	1	0	0	0
	D	0	0	0	0

Results

Results Summary for whole modelled period

Stream	Max RFC	Max Delay (s)	Max Queue (PCU)	Max LOS	Average Demand (PCU/hr)	Total Junction Arrivals (PCU)
B-CD	0.24	36.63	0.3	E	26	38
B-AD	0.28	35.65	0.3	E	29	44
A-BCD	0.03	8.90	0.0	A	14	21
A-B					20	30
A-C					1031	1547
D-AB	0.21	24.01	0.3	C	32	47
D-BC	0.52	43.24	1.0	E	76	114
C-ABD	0.02	9.14	0.0	A	6	8
C-D					118	178
C-A					480	690

T19562
Heyford Park



Appendix N

Junctions 10 Output – A4095/Port Way

Junctions 10
PICADY 10 - Priority Intersection Module
Version: 10 0.2.1576 © Copyright TRL Software Limited, 2021
For sales and distribution information, program advice and maintenance, contact TRL Software: +44 (0)1344 379777 software@trl.co.uk trlsoftware.com
The users of this computer program for the solution of an engineering problem are in no way relieved of their responsibility for the correctness of the solution

Filename: T19562 - A4095-Port Way.j10

Path: C:\Users\MaxLaw\Hub Transport Planning Ltd\Hub Transport Planning - General\Projects\T19562 Heyford Park\Junction Assessments\Picady

Report generation date: 03/12/2021 10:17:46

- »2031 Reference Case, AM
- »2031 Reference Case, PM
- »2031 + Development, AM
- »2031 + Development, PM

Summary of junction performance

	AM					PM				
	Set ID	Queue (PCU)	Delay (s)	RFC	LOS	Set ID	Queue (PCU)	Delay (s)	RFC	LOS
2031 Reference Case										
Stream B-C	D1	0.4	9.38	0.29	A	D2	0.7	10 27	0.42	B
Stream B-A		0.2	14.54	0.15	B		0.2	15 85	0.18	C
Stream C-AB		2.2	18.86	0.67	C		3.9	23 25	0.78	C
2031 + Development										
Stream B-C	D3	0.4	9.43	0.29	A	D4	0.7	10.16	0.41	B
Stream B-A		0.2	14.87	0.15	B		0.2	15 88	0.18	C
Stream C-AB		2.3	19.82	0.68	C		3.9	23 29	0.78	C

There are warnings associated with one or more model runs - see the Data Errors and Warnings tables for each Analysis or Demand Set.

Values shown are the highest values encountered over all time segments. Delay is the maximum value of average delay per arriving vehicle.

File summary

File Description

Title	A4095/Port Way
Location	Heyford Park
Site number	
Date	25/11/2021
Version	
Status	(new file)
Identifier	
Client	Richborough Estates
Jobnumber	T19562
Enumerator	HUBTRANSPORTPLANNING\MaxLaw
Description	

Units

Distance units	Speed units	Traffic units input	Traffic units results	Flow units	Average delay units	Total delay units	Rate of delay units
m	kph	PCU	PCU	perHour	s	-Min	perMin

Analysis Options

Vehicle length (m)	Calculate Queue Percentiles	Calculate detailed queueing delay	Show lane queues in feet / metres	Show all PICADY stream intercepts	Calculate residual capacity	RFC Threshold	Average Delay threshold (s)	Queue threshold (PCU)	Use iterations with HCM roundabouts	Max number of iterations for roundabouts
5.75						0.85	36.00	20.00		500

Demand Set Summary

ID	Scenario name	Time Period name	Traffic profile type	Start time (HH mm)	Finish time (HH mm)	Time segment length (min)	Run automatically
D1	2031 Reference Case	AM	ONE HOUR	07:45	09:15	15	✓
D2	2031 Reference Case	PM	ONE HOUR	16:45	18:15	15	✓
D3	2031 + Development	AM	ONE HOUR	07:45	09:15	15	✓
D4	2031 + Development	PM	ONE HOUR	16:45	18:15	15	✓

Analysis Set Details

ID	Include in report	Network flow scaling factor (%)	Network capacity scaling factor (%)
A1	✓	100.000	100.000

2031 Reference Case, AM

Data Errors and Warnings

Severity	Area	Item	Description
Warning	Minor arm visibility to right	Arm B - Minor arm geometry	Visibility to right expected to have two components if the arm has two lanes, or two lanes in a flared section.

Junction Network

Junctions

Junction	Name	Junction type	Arm A Direction	Arm B Direction	Arm C Direction	Use circulating lanes	Junction Delay (s)	Junction LOS
1	untitled	T-Junction	Two-way	Two-way	Two-way		8.52	A

Junction Network

Driving side	Lighting	Network delay (s)	Network LOS
Left	Normal/unknown	8.52	A

Arms

Arms

Arm	Name	Description	Arm type
A	untitled		Major
B	untitled		Minor
C	untitled		Major

Major Arm Geometry

Arm	Width of carriageway (m)	Has kerbed central reserve	Has right-turn storage	Visibility for right turn (m)	Blocks?	Blocking queue (PCU)
C	6.00			140.0	✓	0.00

Geometries for Arm C are measured opposite Arm B. Geometries for Arm A (if relevant) are measured opposite Arm D.

Minor Arm Geometry

Arm	Minor arm type	Width at give-way (m)	Width at 5m (m)	Width at 10m (m)	Width at 15m (m)	Width at 20m (m)	Estimate flare length	Flare length (PCU)	Visibility to left (m)	Visibility to right (m)
B	One lane plus flare	10.00	6.00	4.00	2.75	2.75	✓	1.00	70	30

Slope / Intercept / Capacity

Priority Intersection Slopes and Intercepts

Stream	Intercept (PCU/hr)	Slope for A-B	Slope for A-C	Slope for C-A	Slope for C-B
B-A	522	0.095	0.240	0.151	0.343
B-C	697	0.107	0.270	-	-
C-B	655	0.254	0.254	-	-

The slopes and intercepts shown above include custom intercept adjustments only.

Streams may be combined, in which case capacity will be adjusted.

Values are shown for the first time segment only; they may differ for subsequent time segments.

Traffic Demand

Demand Set Details

ID	Scenario name	Time Period name	Traffic profile type	Start time (HH mm)	Finish time (HH mm)	Time segment length (min)	Run automatically
D1	2031 Reference Case	AM	ONE HOUR	07:45	09:15	15	✓

Vehicle mix varies over turn	Vehicle mix varies over entry	Vehicle mix source	PCU Factor for a HV (PCU)
✓	✓	HV Percentages	2.00

Demand overview (Traffic)

Arm	Linked arm	Profile type	Use O-D data	Average Demand (PCU/hr)	Scaling Factor (%)
A		ONE HOUR	✓	435	100.000
B		ONE HOUR	✓	191	100.000
C		ONE HOUR	✓	388	100.000

Origin-Destination Data

Demand (PCU/hr)

	To			
	A	B	C	
From	A	0	153	282
	B	40	0	151
	C	81	307	0

Vehicle Mix

Heavy Vehicle Percentages

	To			
	A	B	C	
From	A	0	0	1
	B	0	0	5
	C	2	4	0

Results

Results Summary for whole modelled period

Stream	Max RFC	Max Delay (s)	Max Queue (PCU)	Max LOS	Average Demand (PCU/hr)	Total Junction Arrivals (PCU)
B-C	0.29	9.38	0.4	A	139	208
B-A	0.15	14.54	0.2	B	37	55
C-AB	0.67	18.86	2.2	C	323	485
C-A					33	49
A-B					140	211
A-C					259	388

Main Results for each time segment

07:45 - 08:00

Stream	Total Demand (PCU/hr)	Junction Arrivals (PCU)	Capacity (PCU/hr)	RFC	Throughput (PCU/hr)	Start queue (PCU)	End queue (PCU)	Delay (s)	Unsignalised level of service
B-C	114	28	614	0.185	113	0.0	0.2	7.523	A
B-A	30	8	369	0.082	30	0.0	0.1	10 604	B
C-AB	257	64	614	0.418	254	0.0	0.8	10 303	B
C-A	35	9			35				
A-B	115	29			115				
A-C	212	53			212				

08:00 - 08:15

Stream	Total Demand (PCU/hr)	Junction Arrivals (PCU)	Capacity (PCU/hr)	RFC	Throughput (PCU/hr)	Start queue (PCU)	End queue (PCU)	Delay (s)	Unsignalised level of service
B-C	136	34	596	0.228	135	0.2	0.3	8.197	A
B-A	36	9	337	0.107	36	0.1	0.1	11 946	B
C-AB	314	79	606	0.518	313	0.8	1.2	12 676	B
C-A	35	9			35				
A-B	138	34			138				
A-C	254	63			254				

08:15 - 08:30

Stream	Total Demand (PCU/hr)	Junction Arrivals (PCU)	Capacity (PCU/hr)	RFC	Throughput (PCU/hr)	Start queue (PCU)	End queue (PCU)	Delay (s)	Unsignalised level of service
B-C	166	42	570	0.292	166	0.3	0.4	9.347	A
B-A	44	11	293	0.150	44	0.1	0.2	14.441	B
C-AB	398	100	597	0.667	394	1.2	2.1	18 227	C
C-A	29	7			29				
A-B	168	42			168				
A-C	310	78			310				

08:30 - 08:45

Stream	Total Demand (PCU/hr)	Junction Arrivals (PCU)	Capacity (PCU/hr)	RFC	Throughput (PCU/hr)	Start queue (PCU)	End queue (PCU)	Delay (s)	Unsignalised level of service
B-C	166	42	569	0.292	166	0.4	0.4	9.376	A
B-A	44	11	292	0.151	44	0.2	0.2	14 537	B
C-AB	399	100	597	0.668	399	2.1	2.2	18 855	C
C-A	28	7			28				
A-B	168	42			168				
A-C	310	78			310				

08:45 - 09:00

Stream	Total Demand (PCU/hr)	Junction Arrivals (PCU)	Capacity (PCU/hr)	RFC	Throughput (PCU/hr)	Start queue (PCU)	End queue (PCU)	Delay (s)	Unsignalised level of service
B-C	136	34	596	0.228	136	0.4	0.3	8.230	A
B-A	36	9	335	0.107	36	0.2	0.1	12 042	B
C-AB	315	79	607	0.518	319	2.2	1.2	13.138	B
C-A	34	9			34				
A-B	138	34			138				
A-C	254	63			254				

09:00 - 09:15

Stream	Total Demand (PCU/hr)	Junction Arrivals (PCU)	Capacity (PCU/hr)	RFC	Throughput (PCU/hr)	Start queue (PCU)	End queue (PCU)	Delay (s)	Unsignalised level of service
B-C	114	28	614	0.185	114	0.3	0.2	7.564	A
B-A	30	8	367	0.082	30	0.1	0.1	10 682	B
C-AB	257	64	614	0.419	259	1.2	0.8	10 582	B
C-A	35	9			35				
A-B	115	29			115				
A-C	212	53			212				

2031 Reference Case, PM

Data Errors and Warnings

Severity	Area	Item	Description
Warning	Minor arm visibility to right	Arm B - Minor arm geometry	Visibility to right expected to have two components if the arm has two lanes, or two lanes in a flared section.

Junction Network

Junctions

Junction	Name	Junction type	Arm A Direction	Arm B Direction	Arm C Direction	Use circulating lanes	Junction Delay (s)	Junction LOS
1	untitled	T-Junction	Two-way	Two-way	Two-way		13.03	B

Junction Network

Driving side	Lighting	Network delay (s)	Network LOS
Left	Normal/unknown	13.03	B

Traffic Demand

Demand Set Details

ID	Scenario name	Time Period name	Traffic profile type	Start time (HH mm)	Finish time (HH mm)	Time segment length (min)	Run automatically
D2	2031 Reference Case	PM	ONE HOUR	16:45	18:15	15	✓

Vehicle mix varies over turn	Vehicle mix varies over entry	Vehicle mix source	PCU Factor for a HV (PCU)
✓	✓	HV Percentages	2.00

Demand overview (Traffic)

Arm	Linked arm	Profile type	Use O-D data	Average Demand (PCU/hr)	Scaling Factor (%)
A		ONE HOUR	✓	275	100.000
B		ONE HOUR	✓	276	100.000
C		ONE HOUR	✓	532	100.000

Origin-Destination Data

Demand (PCU/hr)

		To		
		A	B	C
From	A	0	131	144
	B	45	0	231
	C	167	365	0

Vehicle Mix

Heavy Vehicle Percentages

		To		
		A	B	C
From	A	0	0	1
	B	0	0	1
	C	1	1	0

Results

Results Summary for whole modelled period

Stream	Max RFC	Max Delay (s)	Max Queue (PCU)	Max LOS	Average Demand (PCU/hr)	Total Junction Arrivals (PCU)
B-C	0.42	10.27	0.7	B	212	318
B-A	0.18	15.85	0.2	C	41	62
C-AB	0.78	23.25	3.9	C	435	653
C-A					53	80
A-B					120	180
A-C					132	198

Main Results for each time segment

16:45 - 17:00

Stream	Total Demand (PCU/hr)	Junction Arrivals (PCU)	Capacity (PCU/hr)	RFC	Throughput (PCU/hr)	Start queue (PCU)	End queue (PCU)	Delay (s)	Unsignalised level of service
B-C	174	43	644	0.270	172	0.0	0.4	7.684	A
B-A	34	8	362	0.094	33	0.0	0.1	10.951	B
C-AB	336	84	686	0.490	332	0.0	1.1	10.181	B
C-A	64	16			64				
A-B	99	25			99				
A-C	108	27			108				

17:00 - 17:15

Stream	Total Demand (PCU/hr)	Junction Arrivals (PCU)	Capacity (PCU/hr)	RFC	Throughput (PCU/hr)	Start queue (PCU)	End queue (PCU)	Delay (s)	Unsignalised level of service
B-C	208	52	630	0.329	207	0.4	0.5	8.583	A
B-A	40	10	328	0.124	40	0.1	0.1	12.526	B
C-AB	420	105	694	0.605	417	1.1	1.7	13.116	B
C-A	58	15			58				
A-B	118	29			118				
A-C	129	32			129				

17:15 - 17:30

Stream	Total Demand (PCU/hr)	Junction Arrivals (PCU)	Capacity (PCU/hr)	RFC	Throughput (PCU/hr)	Start queue (PCU)	End queue (PCU)	Delay (s)	Unsignalised level of service
B-C	254	64	609	0.418	253	0.5	0.7	10.208	B
B-A	50	12	279	0.178	49	0.1	0.2	15.651	C
C-AB	546	137	704	0.776	538	1.7	3.7	21.444	C
C-A	40	10			40				
A-B	144	36			144				
A-C	159	40			159				

17:30 - 17:45

Stream	Total Demand (PCU/hr)	Junction Arrivals (PCU)	Capacity (PCU/hr)	RFC	Throughput (PCU/hr)	Start queue (PCU)	End queue (PCU)	Delay (s)	Unsignalised level of service
B-C	254	64	608	0.418	254	0.7	0.7	10.274	B
B-A	50	12	277	0.179	50	0.2	0.2	15.846	C
C-AB	548	137	706	0.777	548	3.7	3.9	23.254	C
C-A	37	9			37				
A-B	144	36			144				
A-C	159	40			159				

17:45 - 18:00

Stream	Total Demand (PCU/hr)	Junction Arrivals (PCU)	Capacity (PCU/hr)	RFC	Throughput (PCU/hr)	Start queue (PCU)	End queue (PCU)	Delay (s)	Unsignalised level of service
B-C	208	52	630	0.330	209	0.7	0.5	8.647	A
B-A	40	10	324	0.125	41	0.2	0.1	12.710	B
C-AB	422	106	696	0.607	430	3.9	1.9	14.177	B
C-A	56	14			56				
A-B	118	29			118				
A-C	129	32			129				

18:00 - 18:15

Stream	Total Demand (PCU/hr)	Junction Arrivals (PCU)	Capacity (PCU/hr)	RFC	Throughput (PCU/hr)	Start queue (PCU)	End queue (PCU)	Delay (s)	Unsignalised level of service
B-C	174	43	644	0.270	174	0.5	0.4	7.755	A
B-A	34	8	359	0.094	34	0.1	0.1	11.069	B
C-AB	338	84	687	0.492	341	1.9	1.1	10.613	B
C-A	63	16			63				
A-B	99	25			99				
A-C	108	27			108				

2031 + Development, AM

Data Errors and Warnings

Severity	Area	Item	Description
Warning	Minor arm visibility to right	Arm B - Minor arm geometry	Visibility to right expected to have two components if the arm has two lanes, or two lanes in a flared section.

Junction Network

Junctions

Junction	Name	Junction type	Arm A Direction	Arm B Direction	Arm C Direction	Use circulating lanes	Junction Delay (s)	Junction LOS
1	untitled	T-Junction	Two-way	Two-way	Two-way		8.70	A

Junction Network

Driving side	Lighting	Network delay (s)	Network LOS
Left	Normal/unknown	8.70	A

Traffic Demand

Demand Set Details

ID	Scenario name	Time Period name	Traffic profile type	Start time (HH mm)	Finish time (HH mm)	Time segment length (min)	Run automatically
D3	2031 + Development	AM	ONE HOUR	07:45	09:15	15	✓

Vehicle mix varies over turn	Vehicle mix varies over entry	Vehicle mix source	PCU Factor for a HV (PCU)
✓	✓	HV Percentages	2.00

Demand overview (Traffic)

Arm	Linked arm	Profile type	Use O-D data	Average Demand (PCU/hr)	Scaling Factor (%)
A		ONE HOUR	✓	458	100.000
B		ONE HOUR	✓	187	100.000
C		ONE HOUR	✓	390	100.000

Origin-Destination Data

Demand (PCU/hr)

		To		
		A	B	C
From	A	0	156	302
	B	40	0	147
	C	82	308	0

Vehicle Mix

Heavy Vehicle Percentages

		To		
		A	B	C
From	A	0	0	1
	B	0	0	5
	C	2	5	0

Results

Results Summary for whole modelled period

Stream	Max RFC	Max Delay (s)	Max Queue (PCU)	Max LOS	Average Demand (PCU/hr)	Total Junction Arrivals (PCU)
B-C	0.29	9.43	0.4	A	135	202
B-A	0.15	14.87	0.2	B	37	55
C-AB	0.68	19.82	2.3	C	325	488
C-A					33	49
A-B					143	215
A-C					277	416

Main Results for each time segment

07:45 - 08:00

Stream	Total Demand (PCU/hr)	Junction Arrivals (PCU)	Capacity (PCU/hr)	RFC	Throughput (PCU/hr)	Start queue (PCU)	End queue (PCU)	Delay (s)	Unsignalised level of service
B-C	111	28	610	0.182	110	0.0	0.2	7.548	A
B-A	30	8	365	0.082	30	0.0	0.1	10.717	B
C-AB	258	64	610	0.423	255	0.0	0.8	10 536	B
C-A	36	9			36				
A-B	117	29			117				
A-C	227	57			227				

08:00 - 08:15

Stream	Total Demand (PCU/hr)	Junction Arrivals (PCU)	Capacity (PCU/hr)	RFC	Throughput (PCU/hr)	Start queue (PCU)	End queue (PCU)	Delay (s)	Unsignalised level of service
B-C	132	33	591	0.224	132	0.2	0.3	8.232	A
B-A	36	9	333	0.108	36	0.1	0.1	12.121	B
C-AB	316	79	602	0.525	314	0.8	1.2	13 056	B
C-A	35	9			35				
A-B	140	35			140				
A-C	271	68			271				

08:15 - 08:30

Stream	Total Demand (PCU/hr)	Junction Arrivals (PCU)	Capacity (PCU/hr)	RFC	Throughput (PCU/hr)	Start queue (PCU)	End queue (PCU)	Delay (s)	Unsignalised level of service
B-C	162	40	563	0.288	161	0.3	0.4	9.404	A
B-A	44	11	287	0.153	44	0.1	0.2	14.763	B
C-AB	401	100	591	0.678	397	1.2	2.3	19 094	C
C-A	28	7			28				
A-B	172	43			172				
A-C	333	83			333				

08:30 - 08:45

Stream	Total Demand (PCU/hr)	Junction Arrivals (PCU)	Capacity (PCU/hr)	RFC	Throughput (PCU/hr)	Start queue (PCU)	End queue (PCU)	Delay (s)	Unsignalised level of service
B-C	162	40	563	0.288	162	0.4	0.4	9.433	A
B-A	44	11	286	0.154	44	0.2	0.2	14 867	B
C-AB	402	100	592	0.679	401	2.3	2.3	19 823	C
C-A	28	7			28				
A-B	172	43			172				
A-C	333	83			333				

08:45 - 09:00

Stream	Total Demand (PCU/hr)	Junction Arrivals (PCU)	Capacity (PCU/hr)	RFC	Throughput (PCU/hr)	Start queue (PCU)	End queue (PCU)	Delay (s)	Unsignalised level of service
B-C	132	33	590	0.224	133	0.4	0.3	8.265	A
B-A	36	9	331	0.109	36	0.2	0.1	12 229	B
C-AB	317	79	603	0.525	321	2.3	1.3	13 573	B
C-A	34	8			34				
A-B	140	35			140				
A-C	271	68			271				

09:00 - 09:15

Stream	Total Demand (PCU/hr)	Junction Arrivals (PCU)	Capacity (PCU/hr)	RFC	Throughput (PCU/hr)	Start queue (PCU)	End queue (PCU)	Delay (s)	Unsignalised level of service
B-C	111	28	609	0.182	111	0.3	0.2	7.589	A
B-A	30	8	364	0.083	30	0.1	0.1	10 801	B
C-AB	259	65	610	0.424	260	1.3	0.8	10 830	B
C-A	35	9			35				
A-B	117	29			117				
A-C	227	57			227				

2031 + Development, PM

Data Errors and Warnings

Severity	Area	Item	Description
Warning	Minor arm visibility to right	Arm B - Minor arm geometry	Visibility to right expected to have two components if the arm has two lanes, or two lanes in a flared section.

Junction Network

Junctions

Junction	Name	Junction type	Arm A Direction	Arm B Direction	Arm C Direction	Use circulating lanes	Junction Delay (s)	Junction LOS
1	untitled	T-Junction	Two-way	Two-way	Two-way		12.98	B

Junction Network

Driving side	Lighting	Network delay (s)	Network LOS
Left	Normal/unknown	12.98	B

Traffic Demand

Demand Set Details

ID	Scenario name	Time Period name	Traffic profile type	Start time (HH mm)	Finish time (HH mm)	Time segment length (min)	Run automatically
D4	2031 + Development	PM	ONE HOUR	16:45	18:15	15	✓

Vehicle mix varies over turn	Vehicle mix varies over entry	Vehicle mix source	PCU Factor for a HV (PCU)
✓	✓	HV Percentages	2.00

Demand overview (Traffic)

Arm	Linked arm	Profile type	Use O-D data	Average Demand (PCU/hr)	Scaling Factor (%)
A		ONE HOUR	✓	280	100.000
B		ONE HOUR	✓	271	100.000
C		ONE HOUR	✓	537	100.000

Origin-Destination Data

Demand (PCU/hr)

		To		
		A	B	C
From	A	0	131	149
	B	45	0	226
	C	174	363	0

Vehicle Mix

Heavy Vehicle Percentages

		To		
		A	B	C
From	A	0	0	1
	B	0	0	1
	C	1	1	0

Results

Results Summary for whole modelled period

Stream	Max RFC	Max Delay (s)	Max Queue (PCU)	Max LOS	Average Demand (PCU/hr)	Total Junction Arrivals (PCU)
B-C	0.41	10.16	0.7	B	207	311
B-A	0.18	15.88	0.2	C	41	62
C-AB	0.78	23.29	3.9	C	438	656
C-A					55	83
A-B					120	180
A-C					137	205

Main Results for each time segment

16:45 - 17:00

Stream	Total Demand (PCU/hr)	Junction Arrivals (PCU)	Capacity (PCU/hr)	RFC	Throughput (PCU/hr)	Start queue (PCU)	End queue (PCU)	Delay (s)	Unsignalised level of service
B-C	170	43	643	0.265	169	0.0	0.4	7.641	A
B-A	34	8	361	0.094	33	0.0	0.1	10 977	B
C-AB	337	84	689	0.490	333	0.0	1.1	10.135	B
C-A	67	17			67				
A-B	99	25			99				
A-C	112	28			112				

17:00 - 17:15

Stream	Total Demand (PCU/hr)	Junction Arrivals (PCU)	Capacity (PCU/hr)	RFC	Throughput (PCU/hr)	Start queue (PCU)	End queue (PCU)	Delay (s)	Unsignalised level of service
B-C	203	51	629	0.323	203	0.4	0.5	8.514	A
B-A	40	10	327	0.124	40	0.1	0.1	12 558	B
C-AB	422	105	697	0.606	419	1.1	1.7	13 065	B
C-A	61	15			61				
A-B	118	29			118				
A-C	134	33			134				

17:15 - 17:30

Stream	Total Demand (PCU/hr)	Junction Arrivals (PCU)	Capacity (PCU/hr)	RFC	Throughput (PCU/hr)	Start queue (PCU)	End queue (PCU)	Delay (s)	Unsignalised level of service
B-C	249	62	607	0.410	248	0.5	0.7	10 098	B
B-A	50	12	278	0.178	49	0.1	0.2	15 689	C
C-AB	550	138	708	0.777	542	1.7	3.7	21.442	C
C-A	41	10			41				
A-B	144	36			144				
A-C	164	41			164				

17:30 - 17:45

Stream	Total Demand (PCU/hr)	Junction Arrivals (PCU)	Capacity (PCU/hr)	RFC	Throughput (PCU/hr)	Start queue (PCU)	End queue (PCU)	Delay (s)	Unsignalised level of service
B-C	249	62	607	0.410	249	0.7	0.7	10.160	B
B-A	50	12	276	0.179	50	0.2	0.2	15 885	C
C-AB	553	138	710	0.779	552	3.7	3.9	23 293	C
C-A	39	10			39				
A-B	144	36			144				
A-C	164	41			164				

17:45 - 18:00

Stream	Total Demand (PCU/hr)	Junction Arrivals (PCU)	Capacity (PCU/hr)	RFC	Throughput (PCU/hr)	Start queue (PCU)	End queue (PCU)	Delay (s)	Unsignalised level of service
B-C	203	51	629	0.323	204	0.7	0.5	8.579	A
B-A	40	10	324	0.125	41	0.2	0.1	12.744	B
C-AB	424	106	699	0.607	433	3.9	1.9	14.138	B
C-A	58	15			58				
A-B	118	29			118				
A-C	134	33			134				

18:00 - 18:15

Stream	Total Demand (PCU/hr)	Junction Arrivals (PCU)	Capacity (PCU/hr)	RFC	Throughput (PCU/hr)	Start queue (PCU)	End queue (PCU)	Delay (s)	Unsignalised level of service
B-C	170	43	643	0.265	171	0.5	0.4	7.711	A
B-A	34	8	359	0.094	34	0.1	0.1	11.095	B
C-AB	339	85	690	0.491	342	1.9	1.1	10.566	B
C-A	65	16			65				
A-B	99	25			99				
A-C	112	28			112				