

ED04
Section 1:20

ED04
External Elevation 1:20

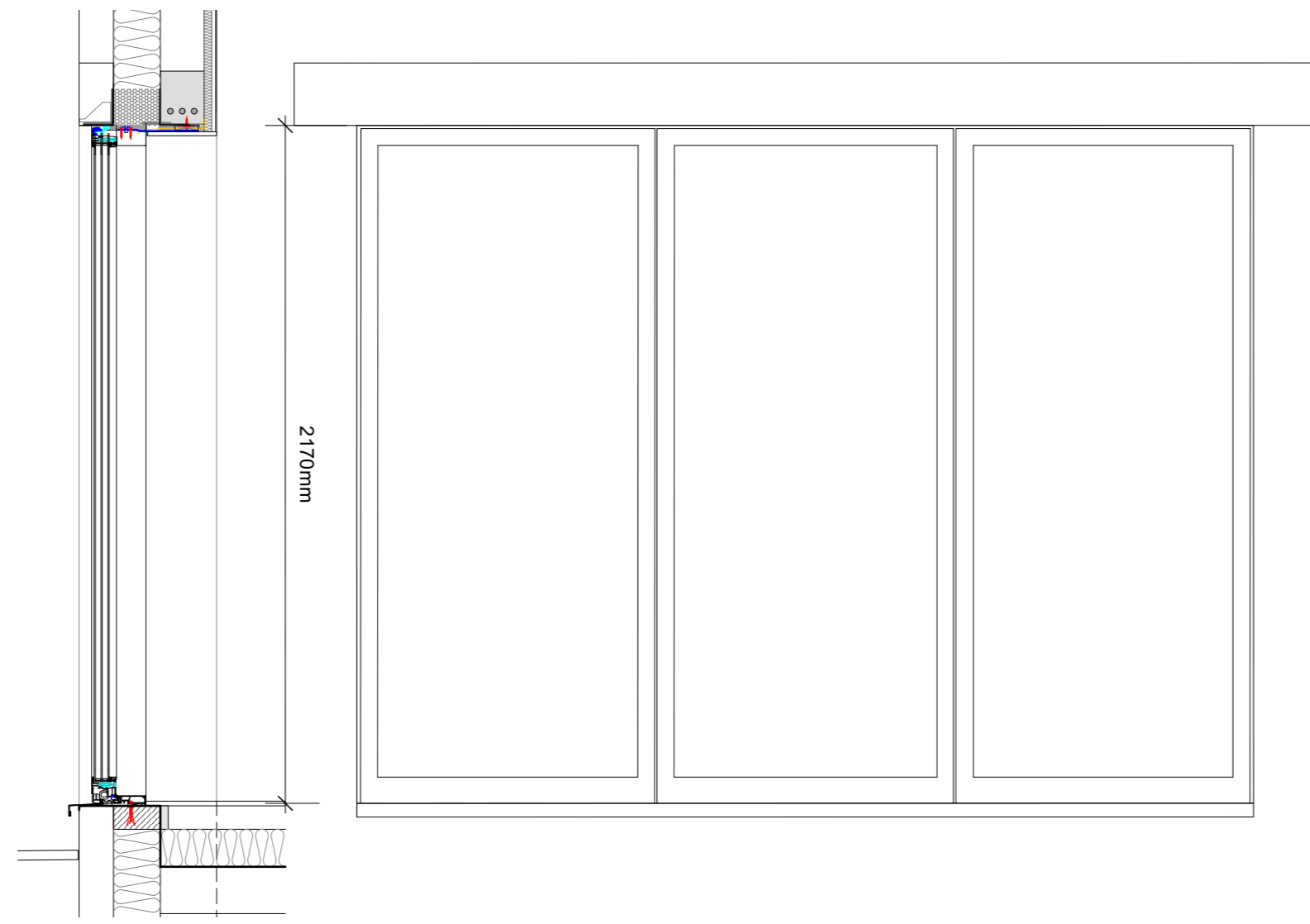

ED05 & ED09
Section 1:20

ED05 & ED09
External Elevation 1:20

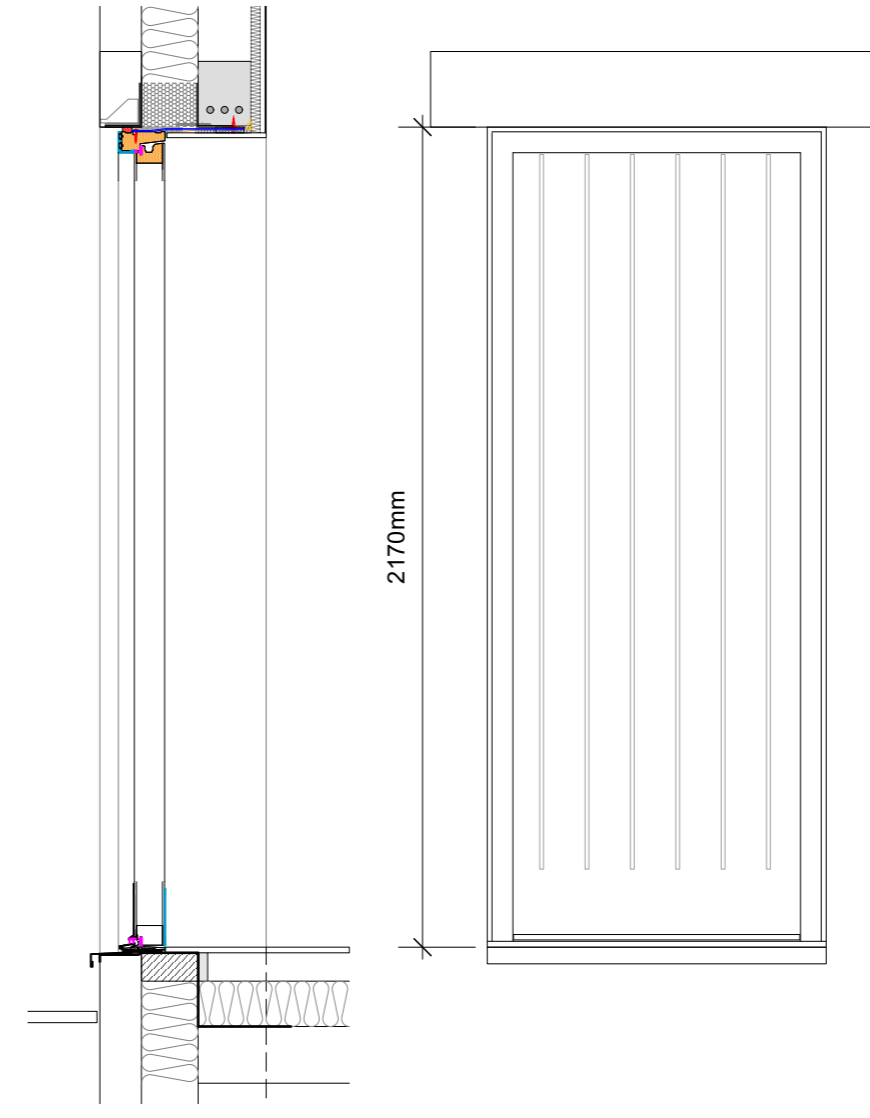

ED06
Section 1:20

ED06
External Elevation 1:20

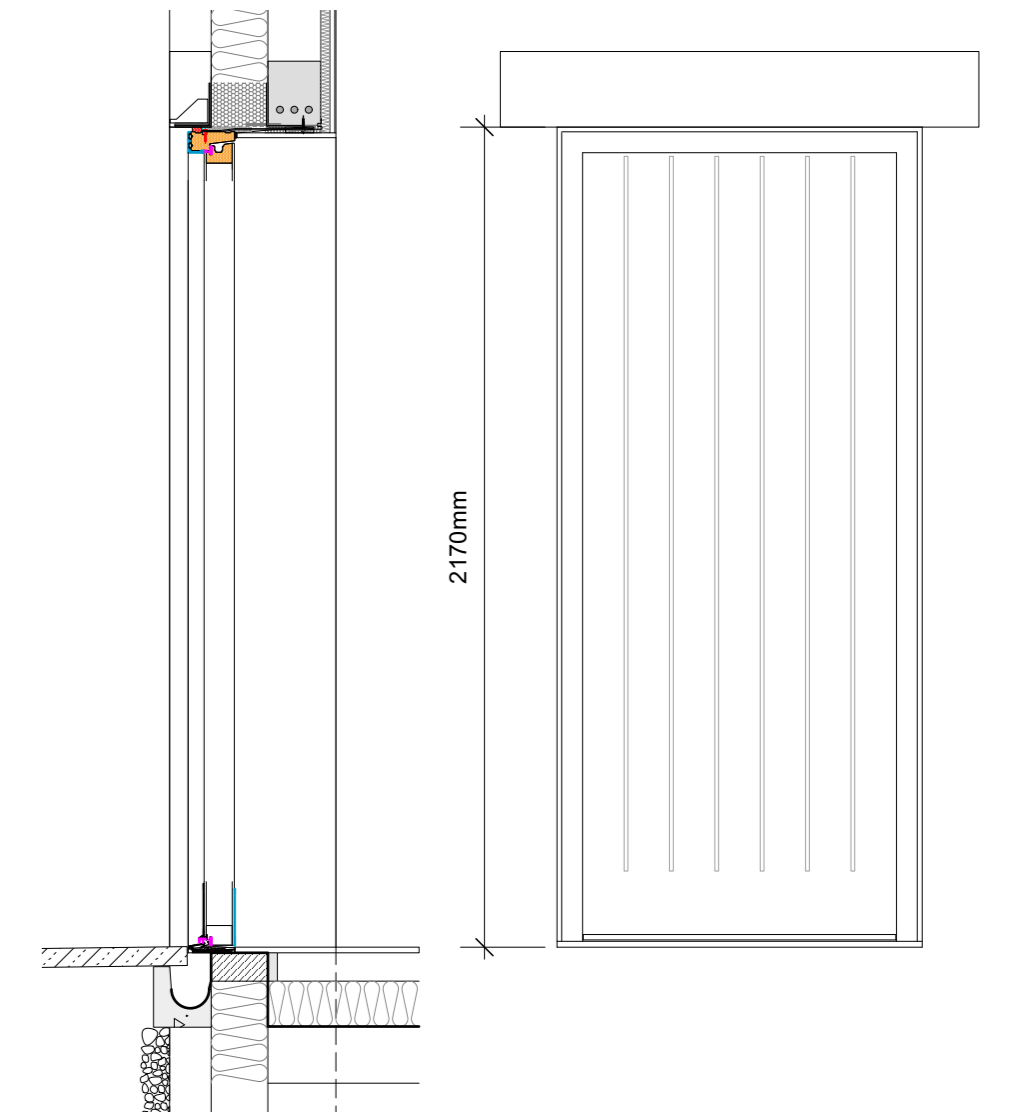

ED07 Front Door
Section 1:20

ED07 Front Door
External Elevation 1:20

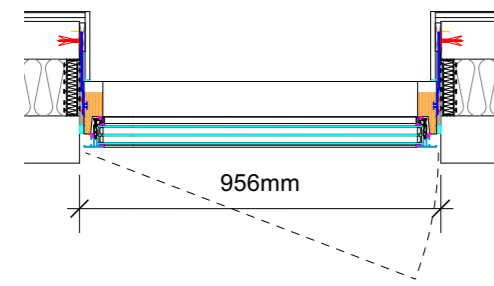

ED04
Plan 1:20

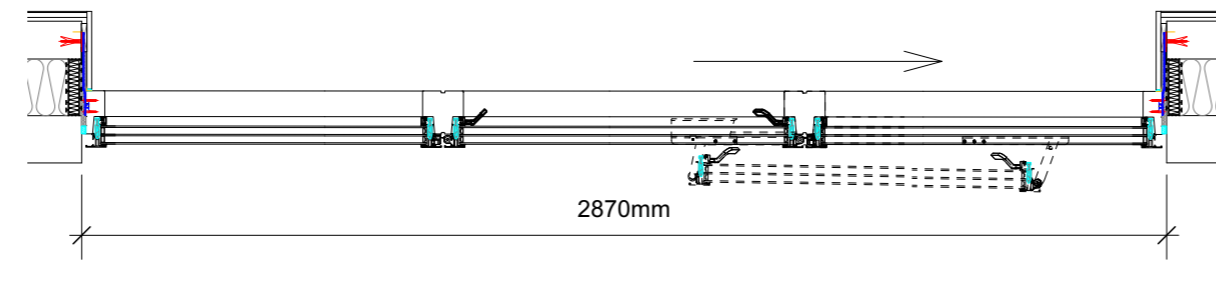

ED05 & ED09
Plan 1:20

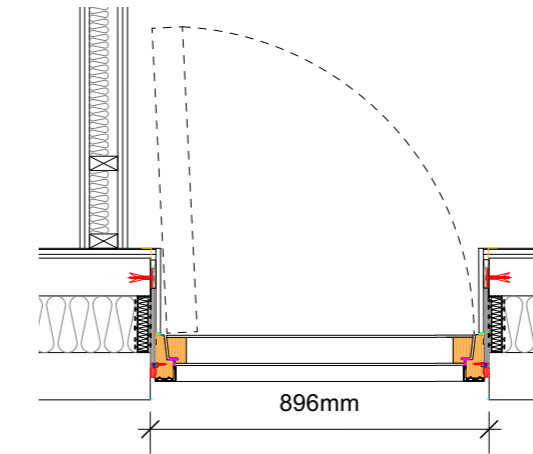

ED06
Plan 1:20

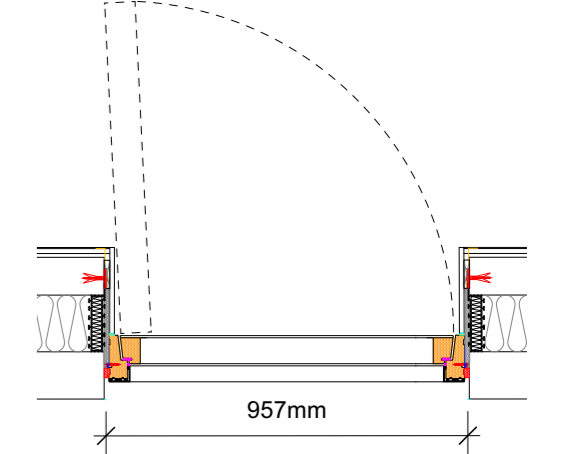

ED07 Front Door
Plan 1:20

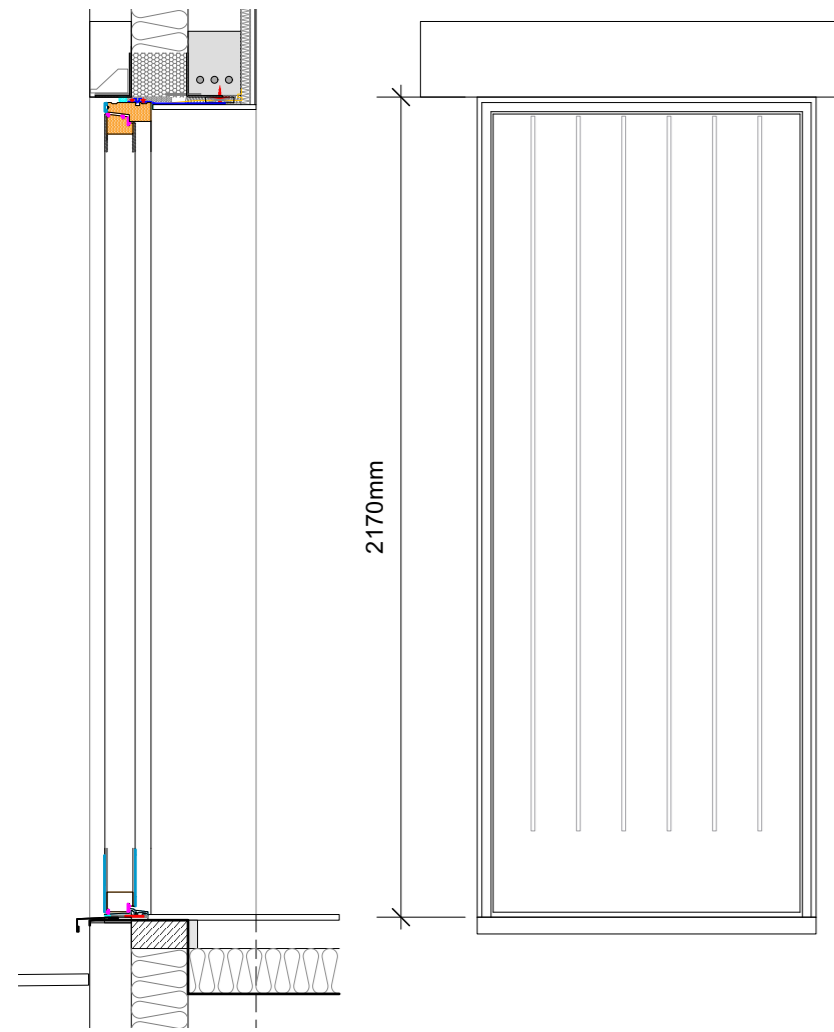

ED08
Section 1:20

ED08
External Elevation 1:20

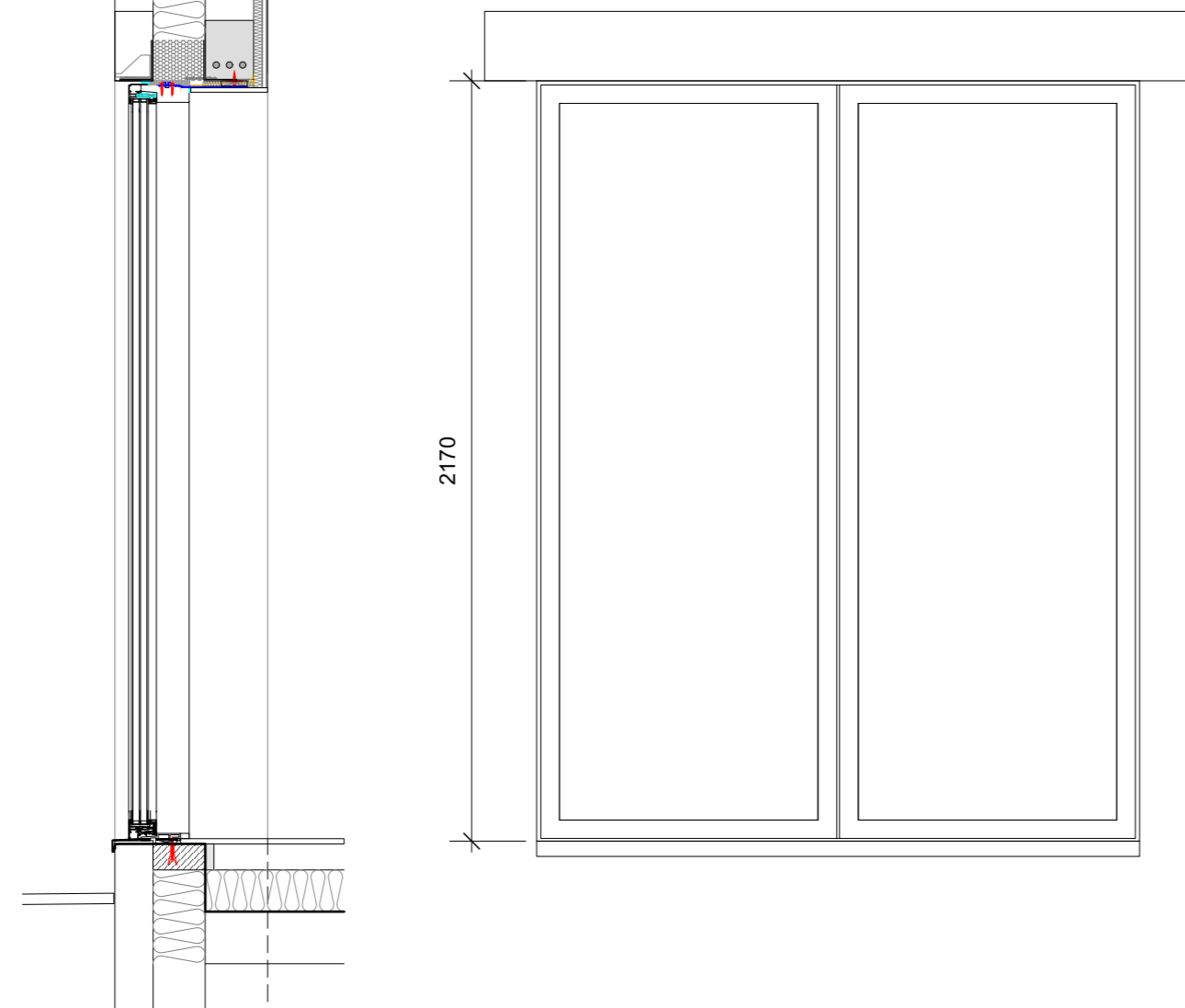

ED10
Section 1:20

ED10
External Elevation 1:20

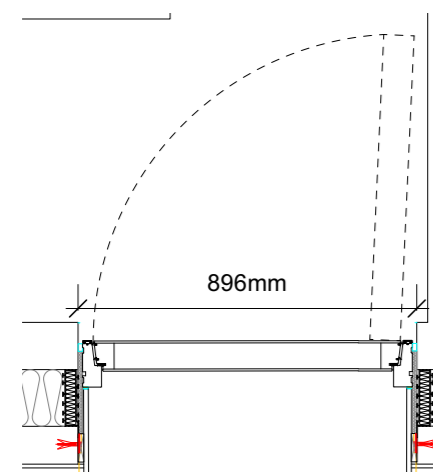

ED08
Plan 1:20

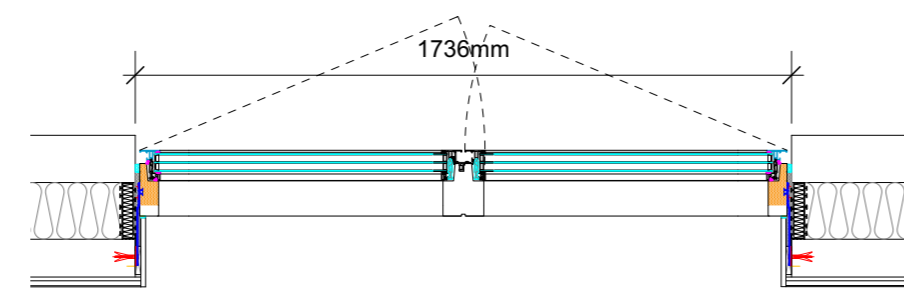

ED10
Plan 1:20

- Notes**
1. This drawing remains copyright of Blake Architects Limited and may not be reproduced or copied without consent in writing.
 2. For construction use figured dimensions only.
 3. Any discrepancies between site and drawings to be reported to the architect immediately.
 4. Read in conjunction with all relevant structural and mechanical & electrical engineers drawings.
 5. Survey undertaken by:

REVISIONS				
PROJECT	Crockwell			
ADDRESS	Crockwell House Farm, Manor Road, Great Bourton, OX17 1QT			
TITLE	Blake Architects Limited			
	1 Coves Barn, Winstone, Cirencester Gloucestershire GL7 7JZ [t] 01285 841407 [e] mail@blakearchitects.co.uk www.blakearchitects.co.uk			
TITLE	External Door Details			
DRAWING NUMBER	21.02.04.23			
STATUS	Tender			
DRAWN	CHECKED	DATE	SCALE	REVISION
GY	JN	16.06.22		