

Section Elevation

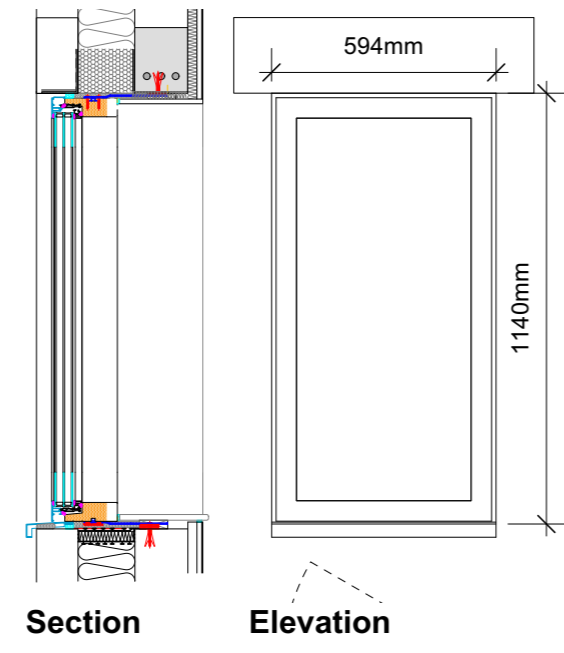

Section Elevation

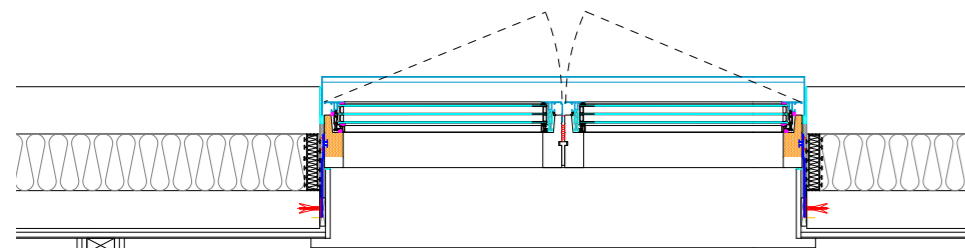

Plan

W01, W02, W03, W09, W11 Windows

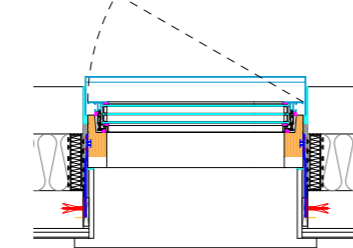

Plan

W10 Bathroom Window

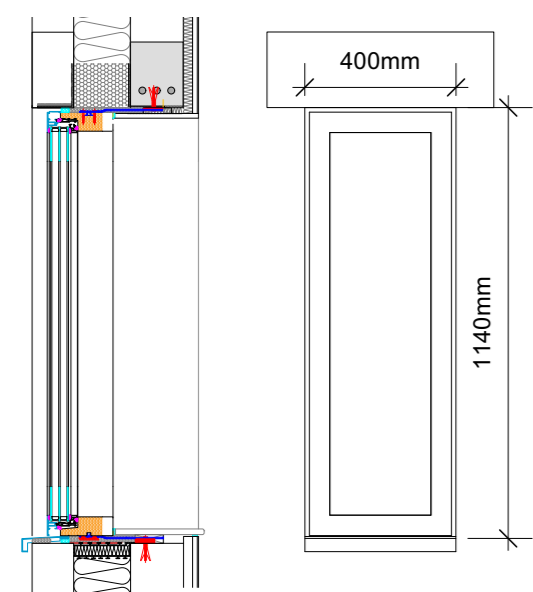

Section Elevation

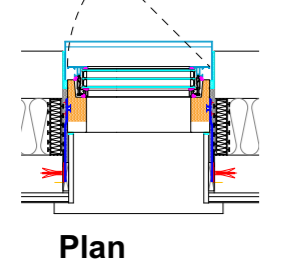

Plan

W04, W05, W06, W07, W08 Windows

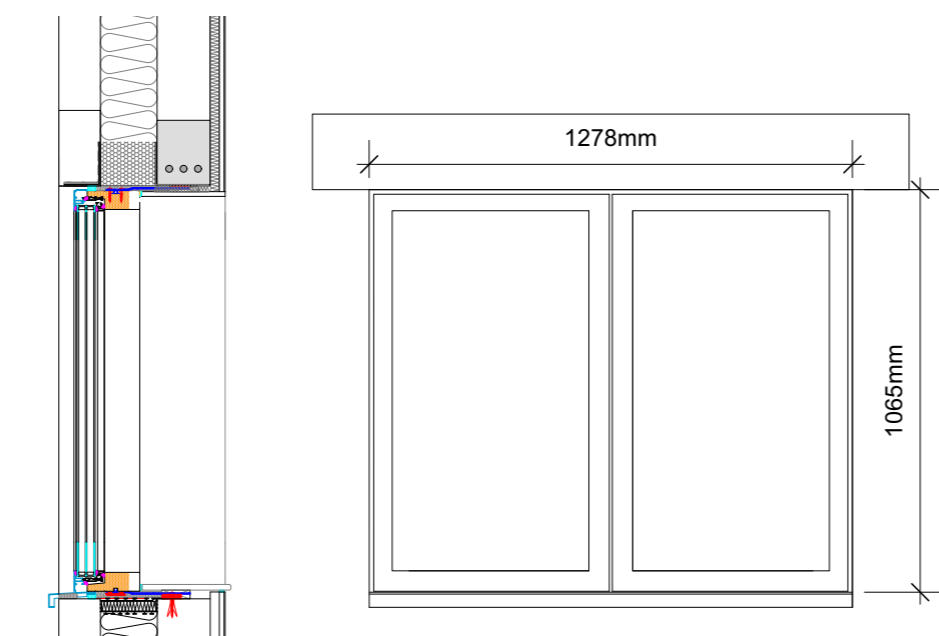

Section Elevation

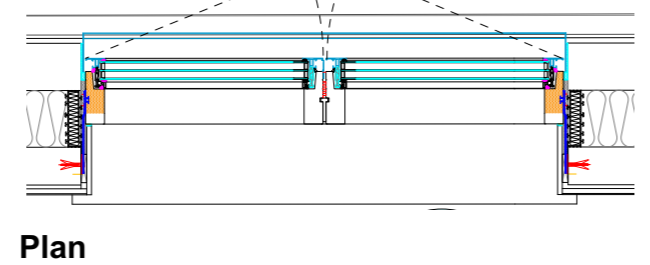

Plan

W20, W21, W22 Windows

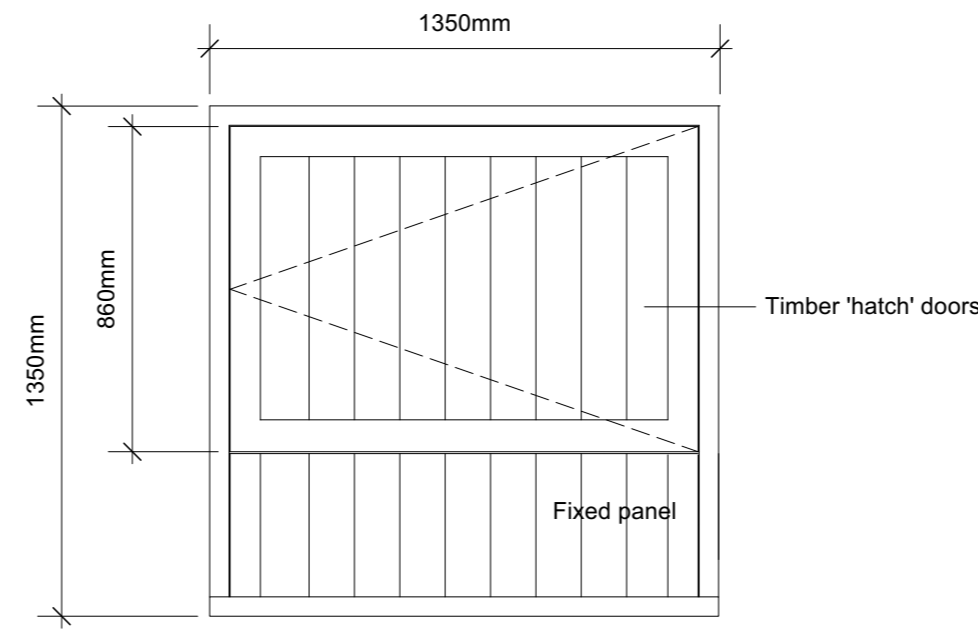

Elevation

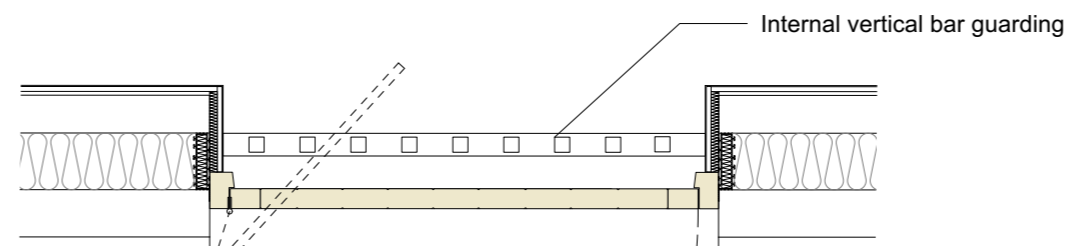

Plan

W31 & W32 hatches

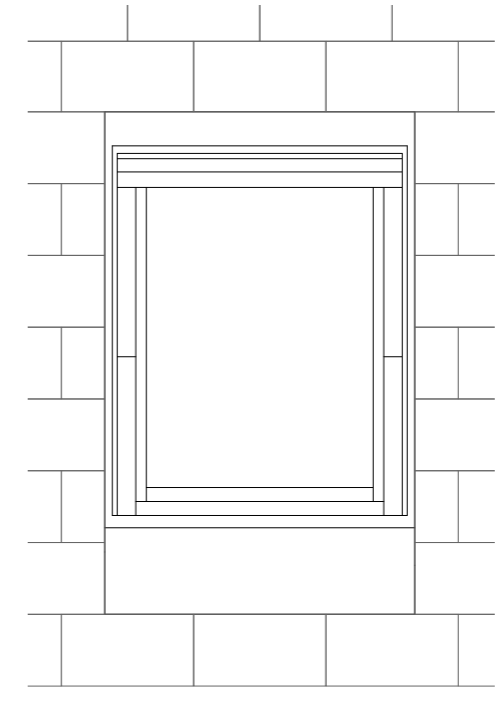

Rooflight Details Elevation Velux Rooflight, centre pivot

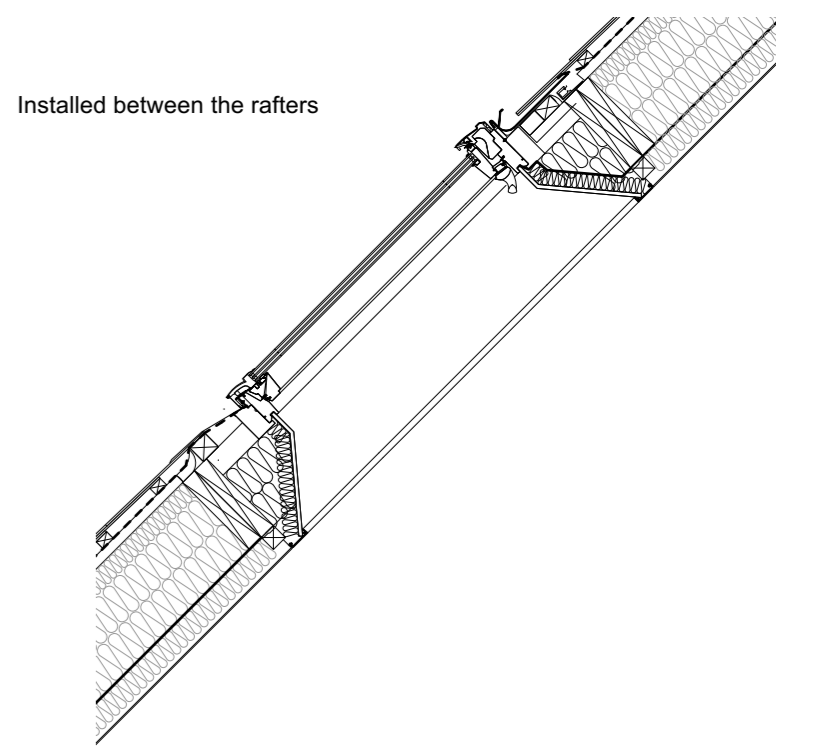

Rooflight Details Section Velux Rooflight, centre pivot

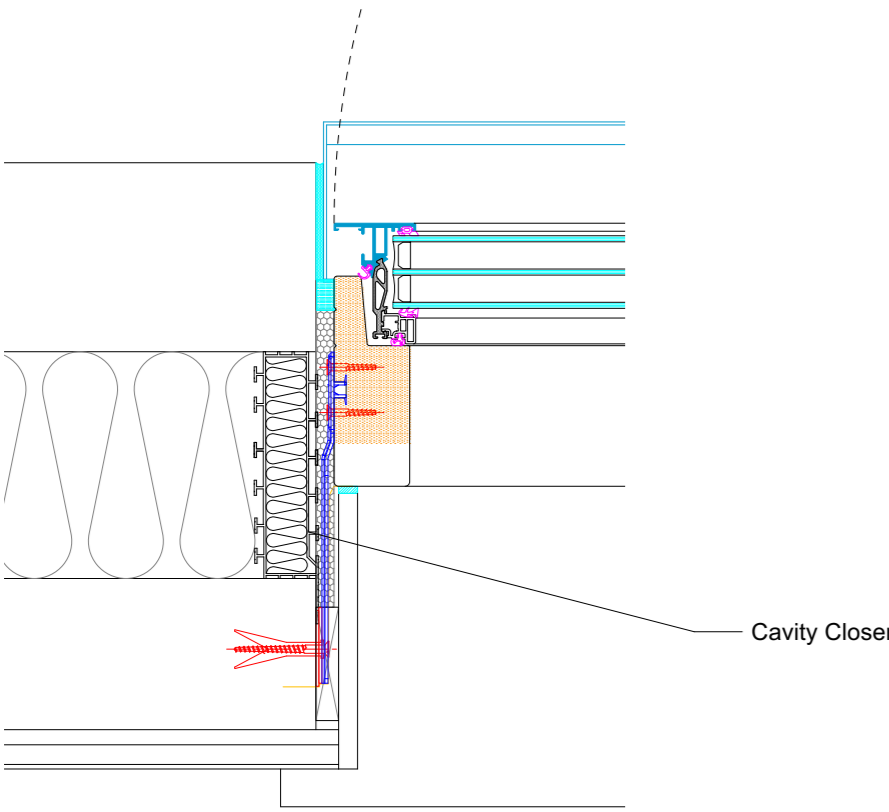

Typical Jamb Detail 1:5

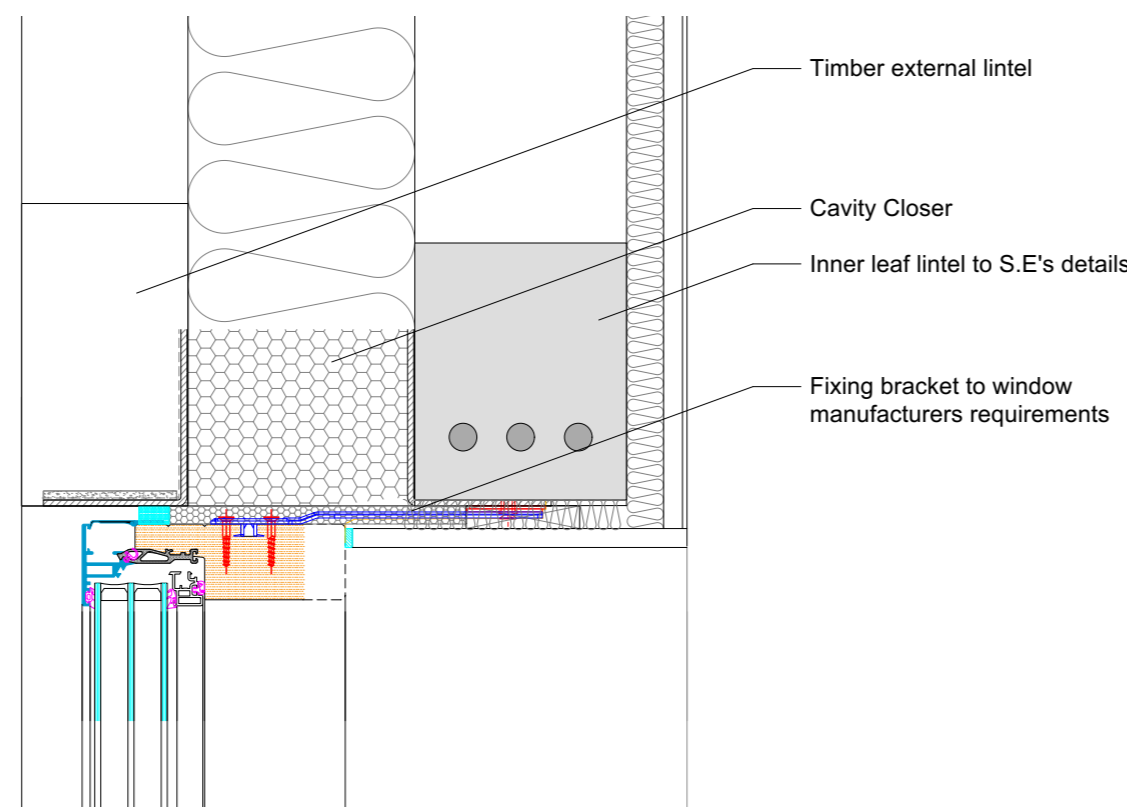

Typical Head Detail 1:5

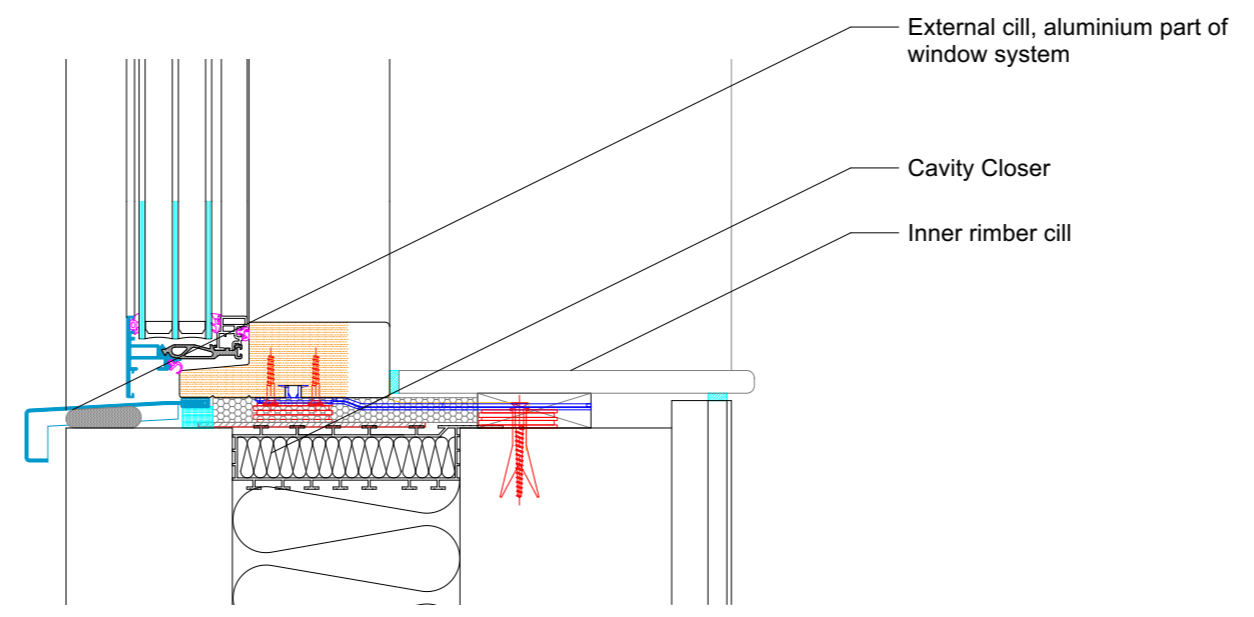

Typical Cill Detail 1:5

- Notes**
1. This drawing remains copyright of Blake Architects Limited and may not be reproduced or copied without consent in writing.
  2. For construction use figured dimensions only.
  3. Any discrepancies between site and drawings to be reported to the architect immediately.
  4. Read in conjunction with all relevant structural and mechanical & electrical engineers drawings.
  5. Survey undertaken by:

REVISIONS				
PROJECT	Crockwell			
ADDRESS	Crockwell House Farm, Manor Road, Great Bourton, OX17 1QT			
DRAWING NUMBER	21.02.04.24			
	21.02.04.24			
STATUS	Tender			
DRAWN	CHECKED	DATE	SCALE	REVISION
GY	JN	16.06.22		

**Blake Architects Limited**  
 1 Coves Barn, Winstone, Cirencester Gloucestershire GL7 7JZ  
 [t] 01285 841407 [e] mail@blakearchitects.co.uk  
 www.blakearchitects.co.uk

TITLE Window Details