

Interceptor 8 Location 1:50

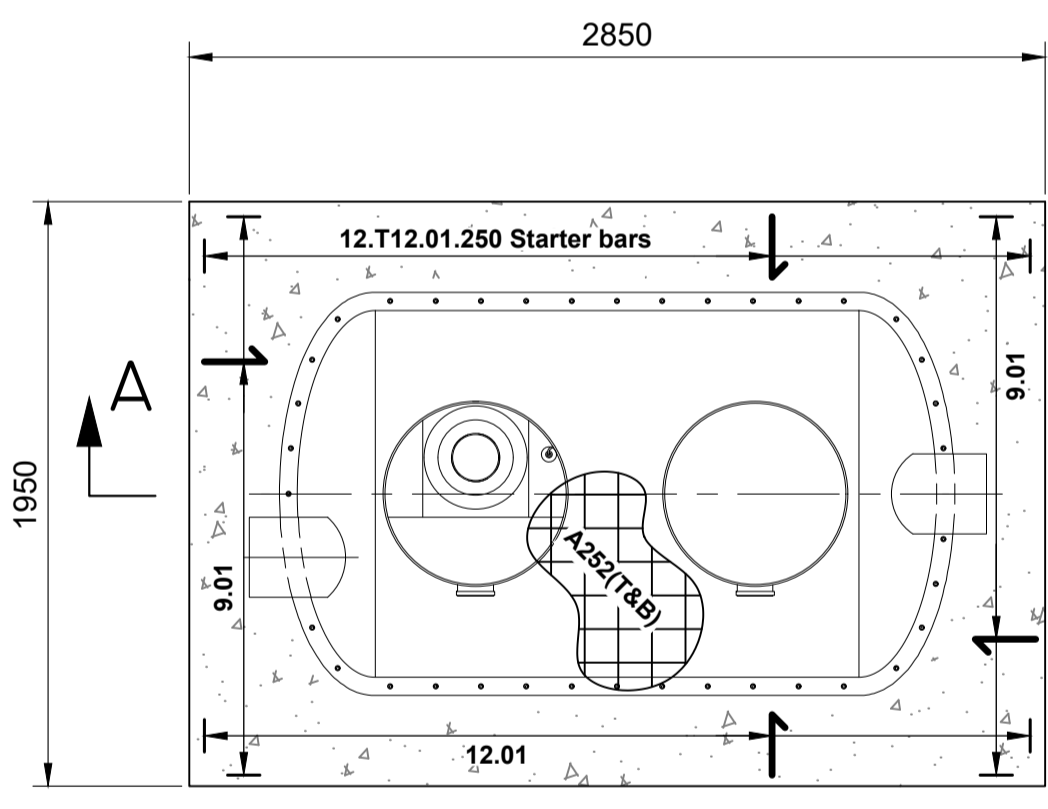

BASE PLAN 1:25

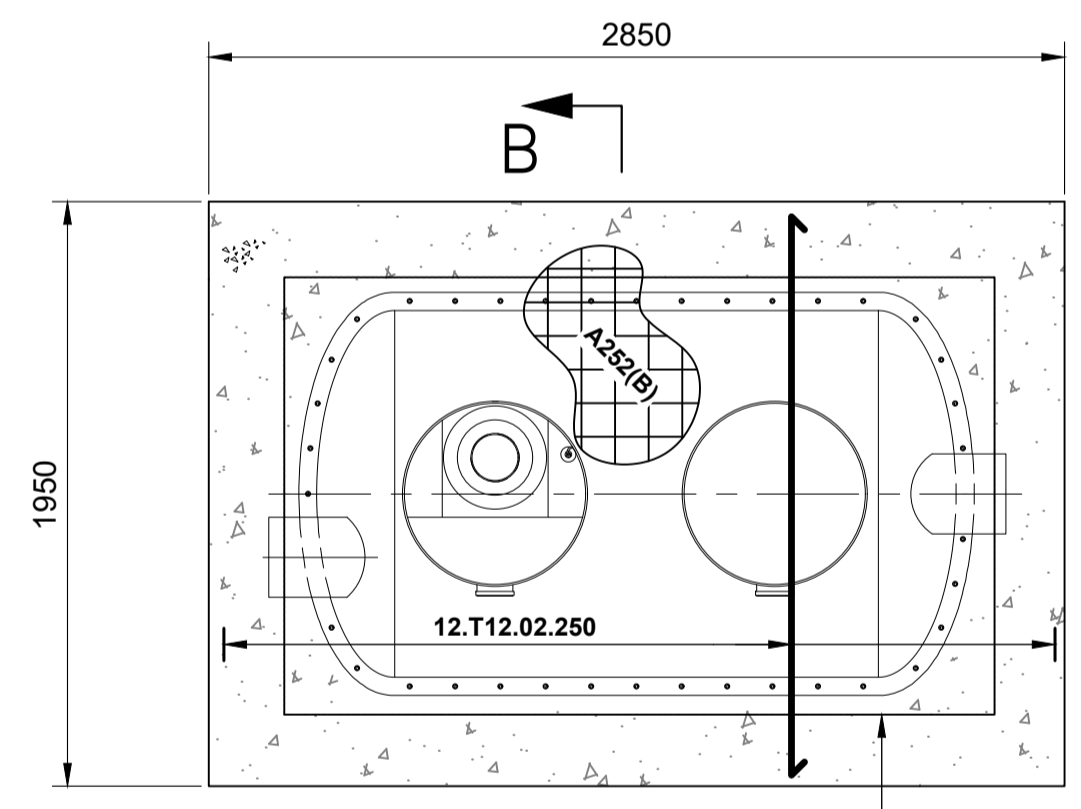

TOP PLAN 1:25

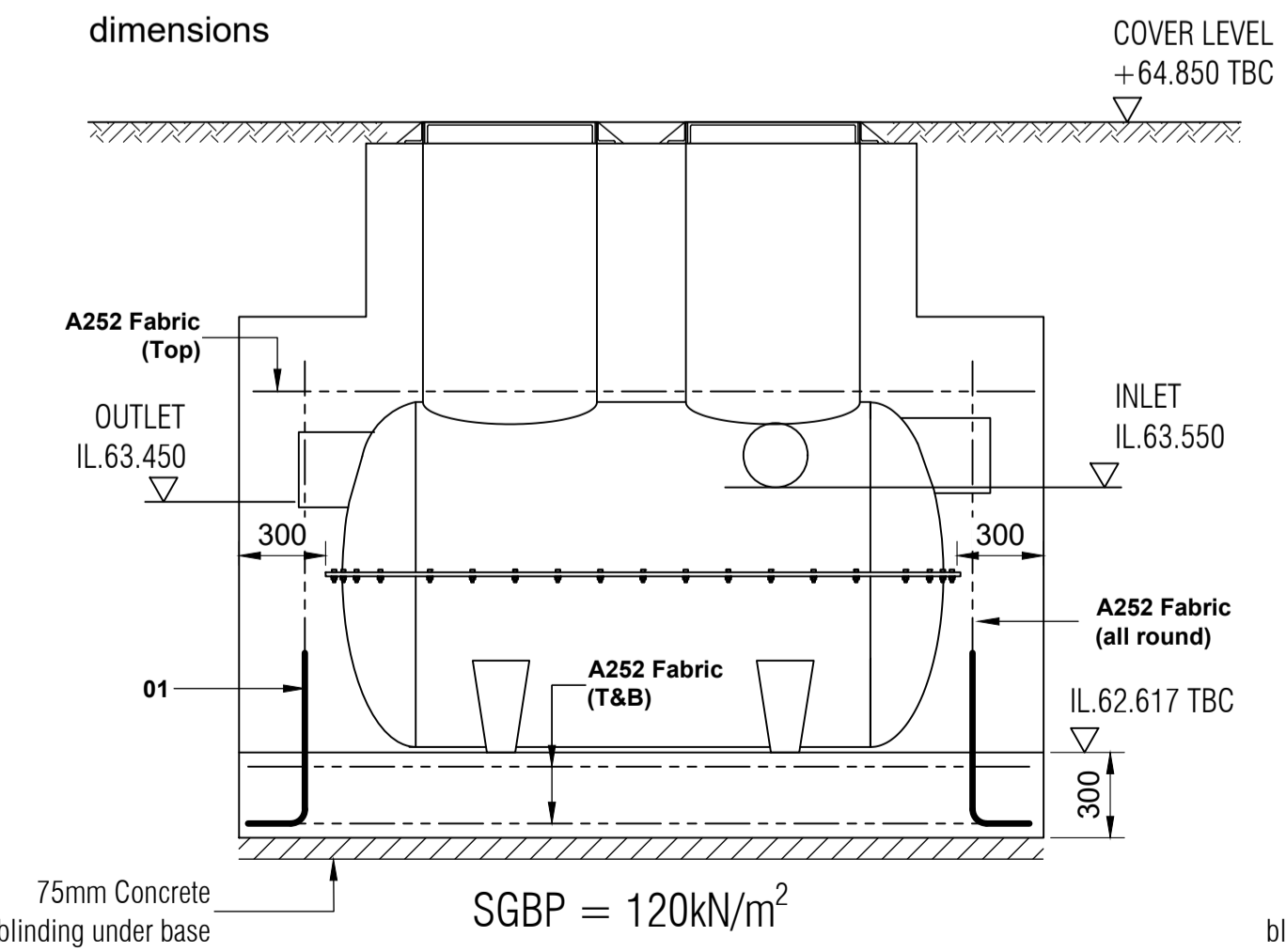

SECTION A-A 1:25

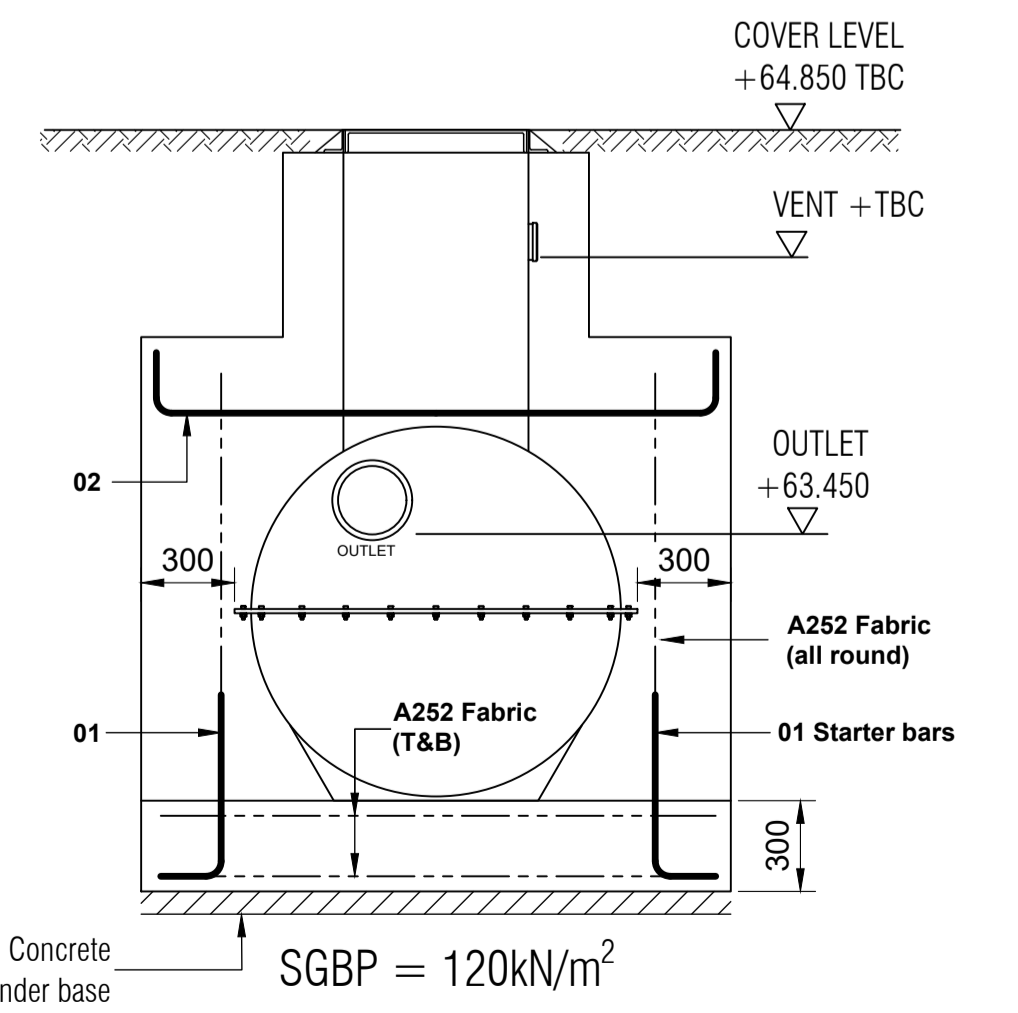

SECTION B-B 1:25

Petrol Interceptor (8)
 Ref: NSBP 6 or similar approved
 Cover Level = 64.850
 Invert Level = 62.617
 +300mm (min) RC encasement all round

MARSH NSBP 6 (CLASS 1) BY-PASS SEPARATOR
 Ø 1.35m x 2.25m LONG TANK
 300 TWINWALL INLET / OUTLET (STANDARD DUTY SHELL)

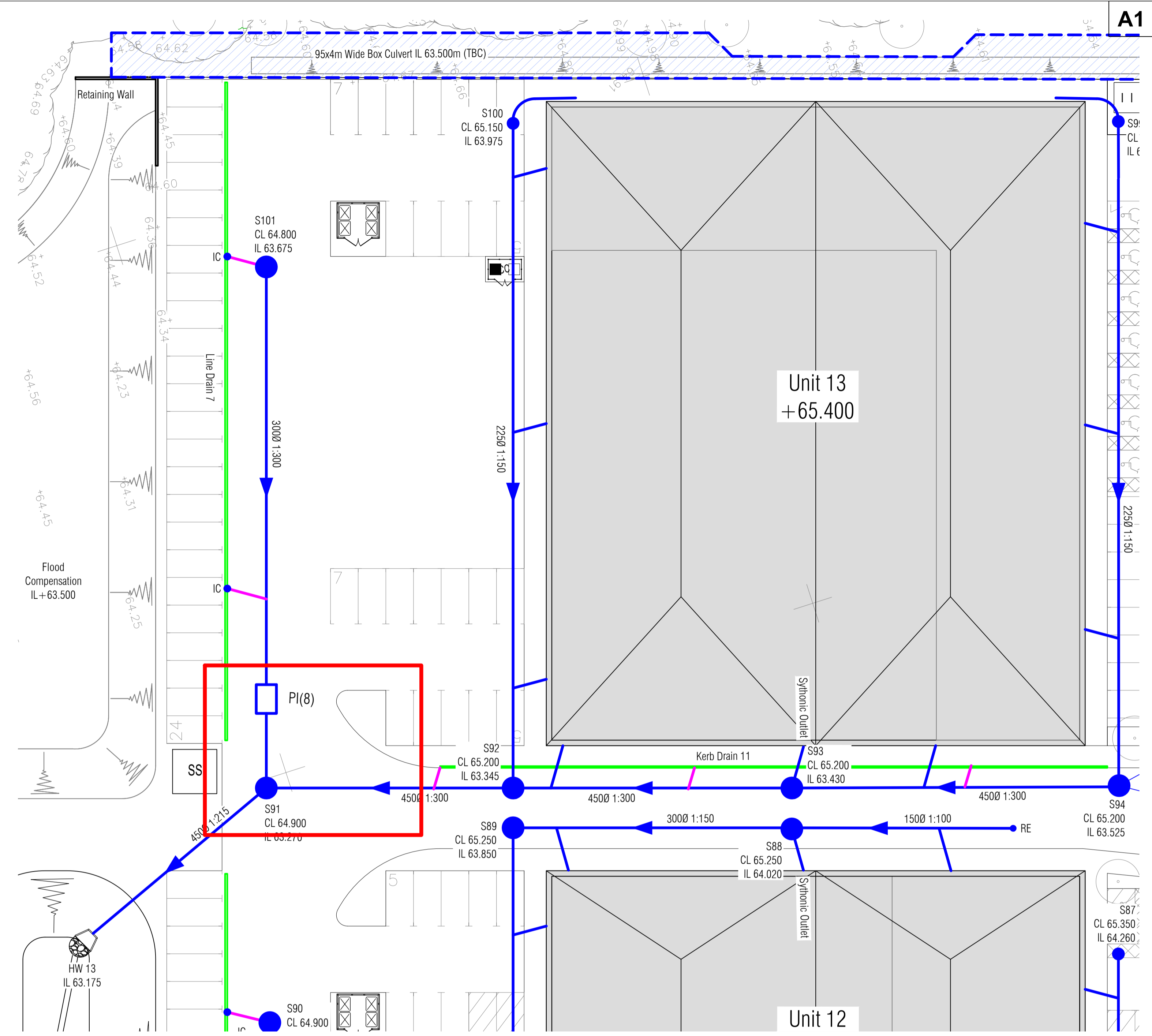
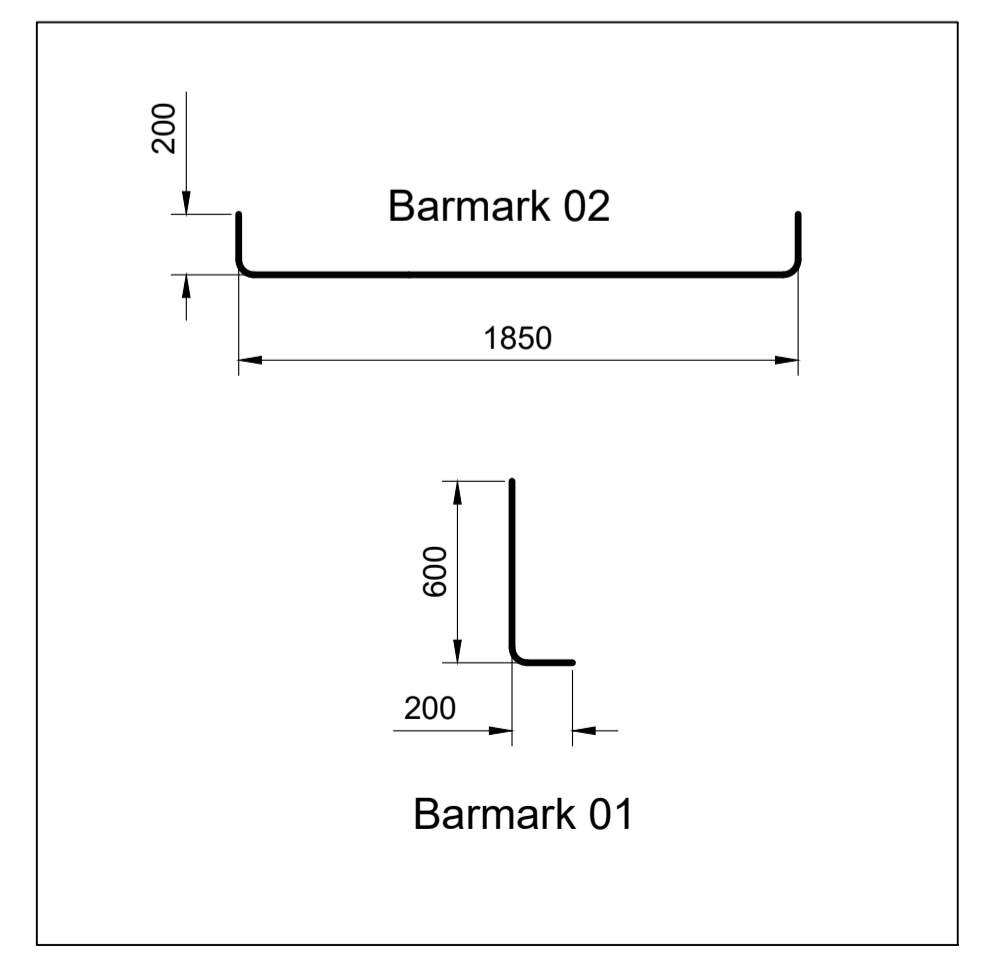

Unit 13 Drainage Key Plan 1:250

TOWN PLANNING

Rev	Date	Revision Description
Revision Schedule		
Project Title Catalyst Bicester Wendlebury Road, Bicester		
Client ALBION LAND		
Drawing Title PHASE 3 Unit 13 Interceptor (8) Details		
BAILEY JOHNSON HAYES Consulting Engineers		
ST ALBANS: Suite 4, Phoenix House, 63 Campfield Rd, ST ALBANS, Herts AL1 5FL MANCHESTER: Grange House, John Dalton Street, MANCHESTER, M2 6FW		
Scale	1:50,25 @A1	Drawing Number
Date	30.01.23	S1358-PH3-16
Drawn	DC	