

Unit 5 Interceptor Location 1:50

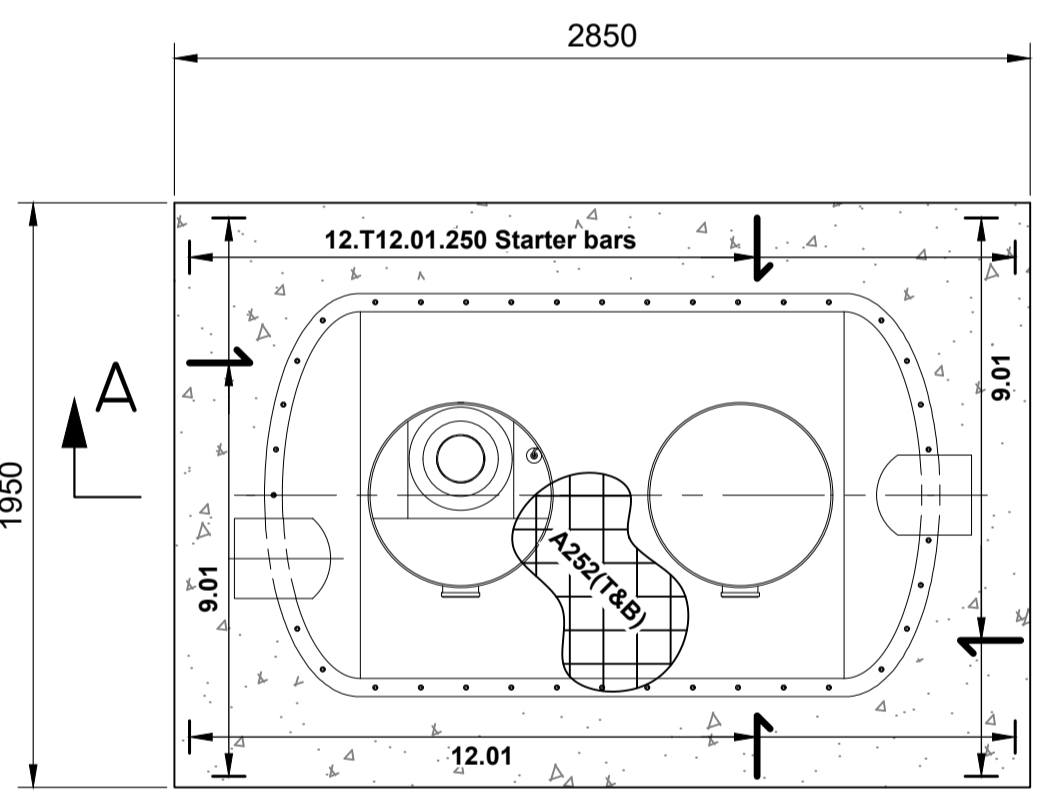

BASE PLAN 1:25

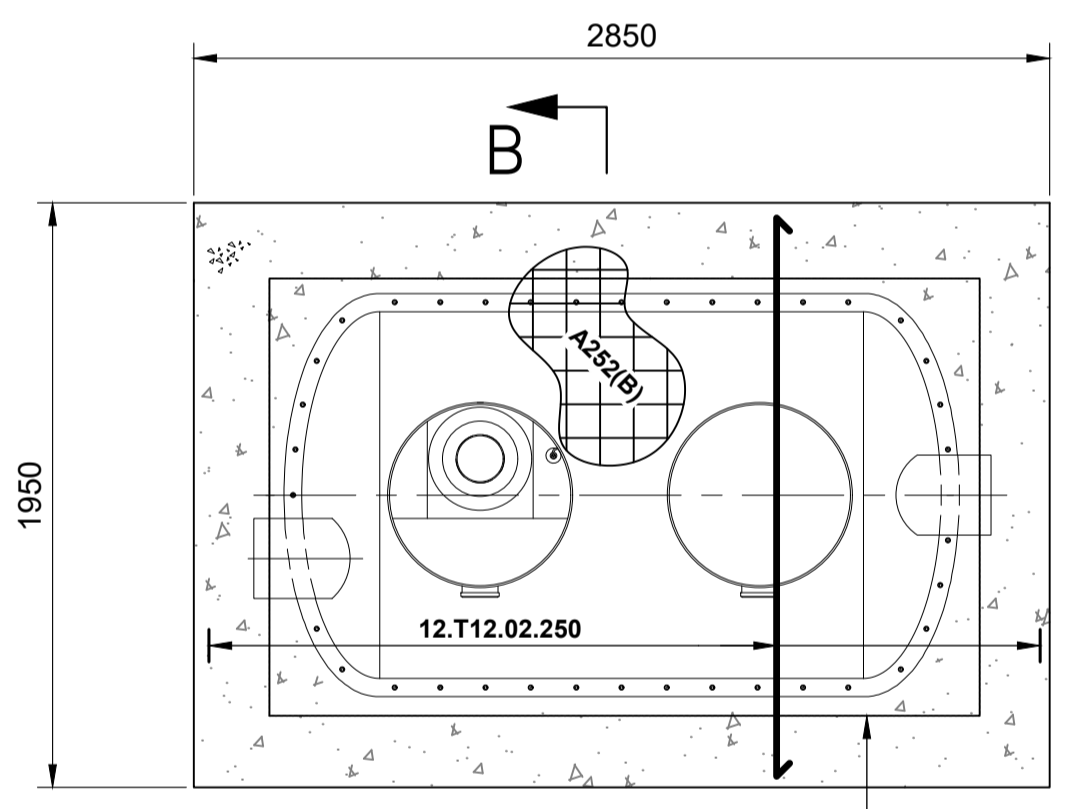

TOP PLAN 1:25

Petrol Interceptor (3)  
 Ref: NSBP 8 or similar approved  
 Cover Level = 64.800  
 Invert Level = 62.440  
 +300mm (min) RC encasement all round

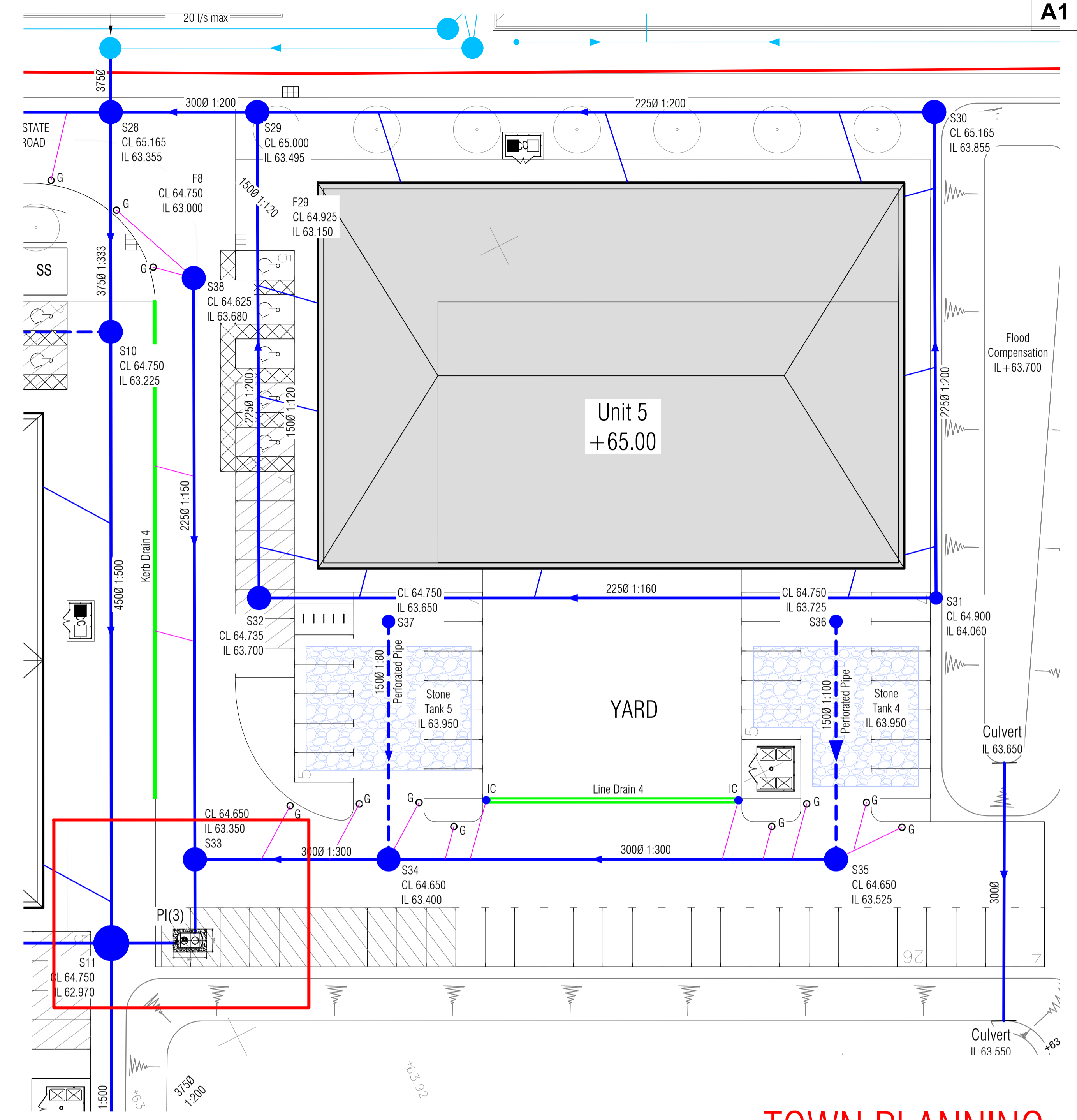

Unit 5 Drainage Key Plan 1:250

MARSH NSBP 8 (CLASS 1)  
 BY-PASS SEPARATOR  
 Ø 1.35m x 2.25m LONG TANK  
 375 TWINWALL INLET / OUTLET  
 (STANDARD DUTY SHELL)

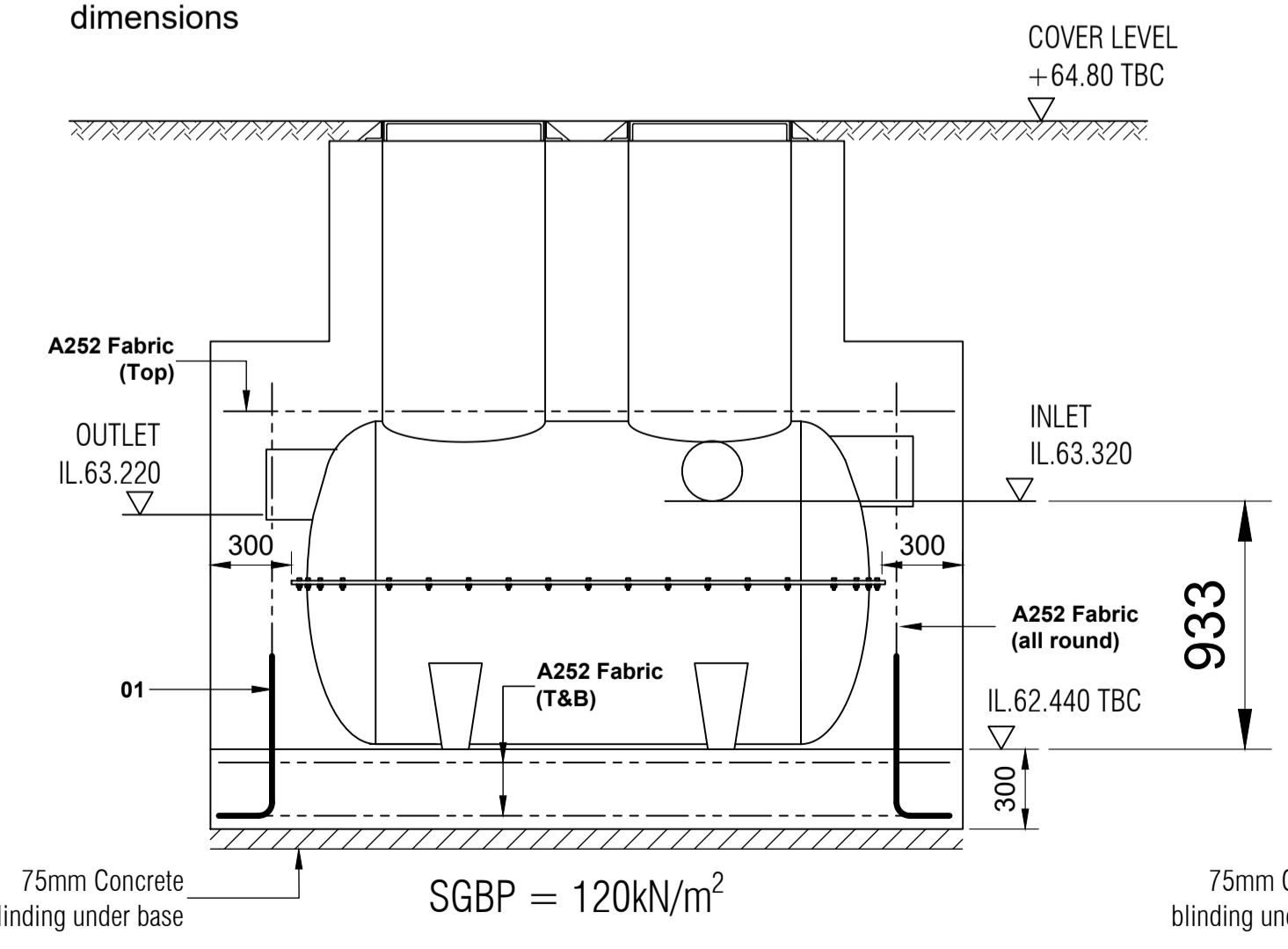

SECTION A-A 1:25

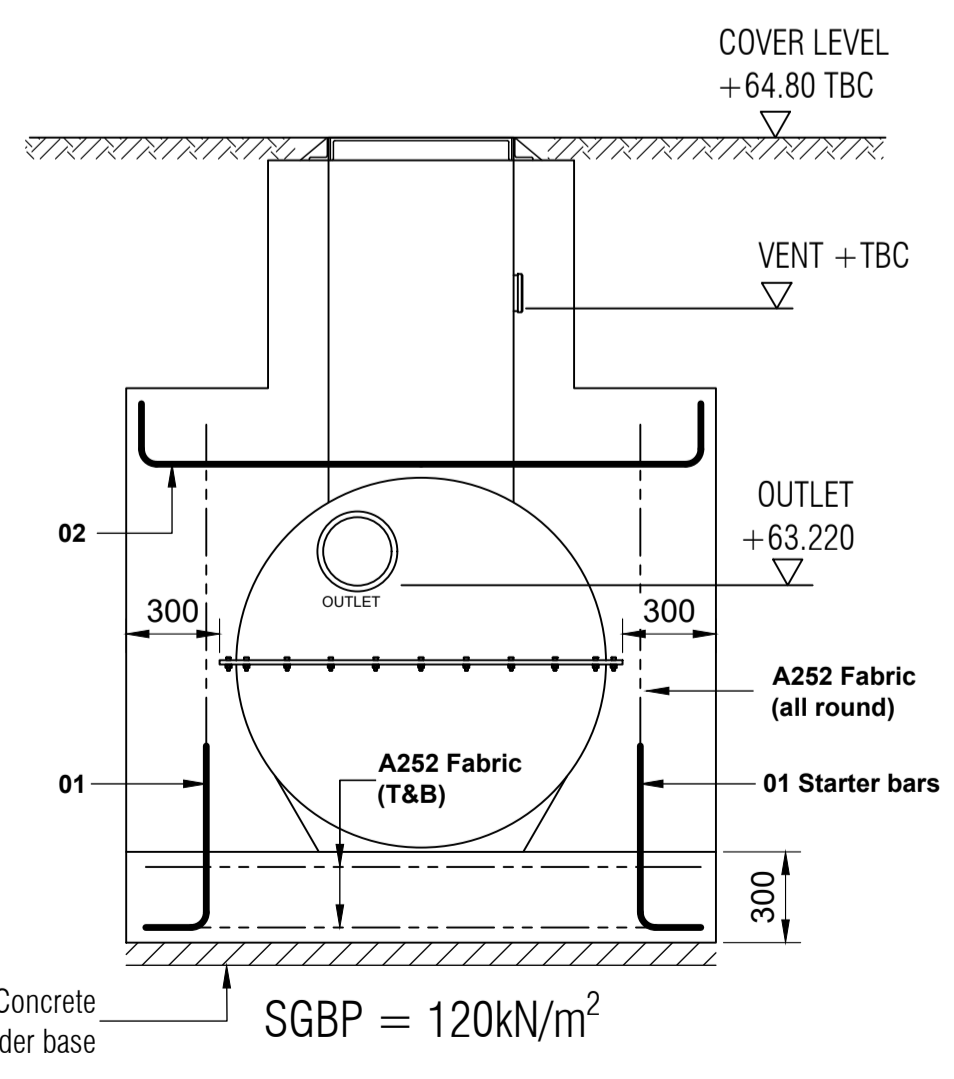

SECTION B-B 1:25

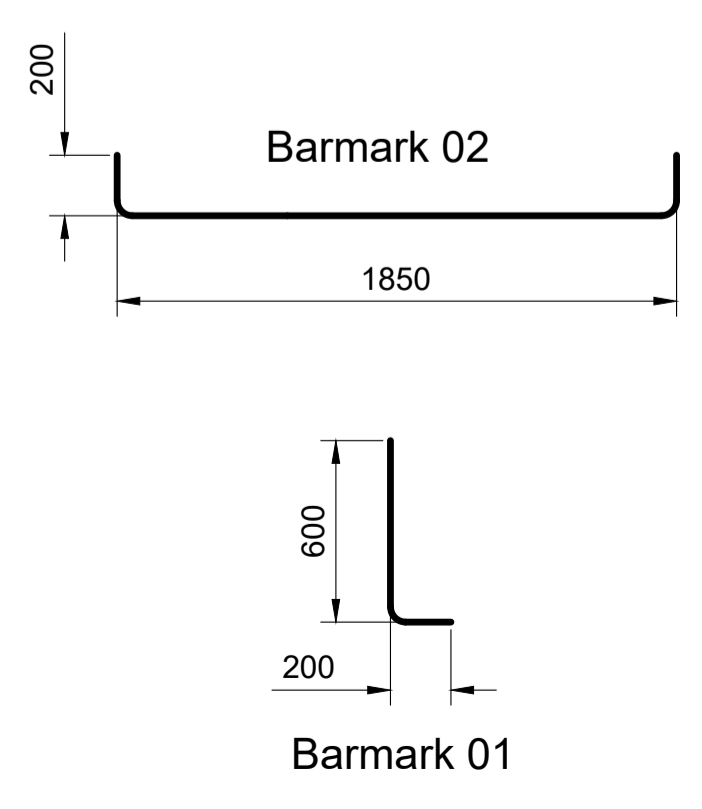

TOWN PLANNING

Rev	Date	Revision Description
Revision Schedule		
Project Title Catalyst Bicester Wendlebury Road, Bicester		
Client ALBION LAND		
Drawing Title PHASE 2 Unit 5 Interceptor (3) Details		
BAILEY JOHNSON HAYES Consulting Engineers		
ST. ALBANS: Suite 4, Phoenix House, 63 Campfield Rd, ST. ALBANS, Herts AL1 5FL MANCHESTER: Grange House, John Dalton Street, MANCHESTER, M2 6FW		
Scale 1:50,25 @A1	Drawing Number S1358-PH2-18	
Date 17.01.23	Drawn DC	