

Unit 6 External Works Layout 1:250

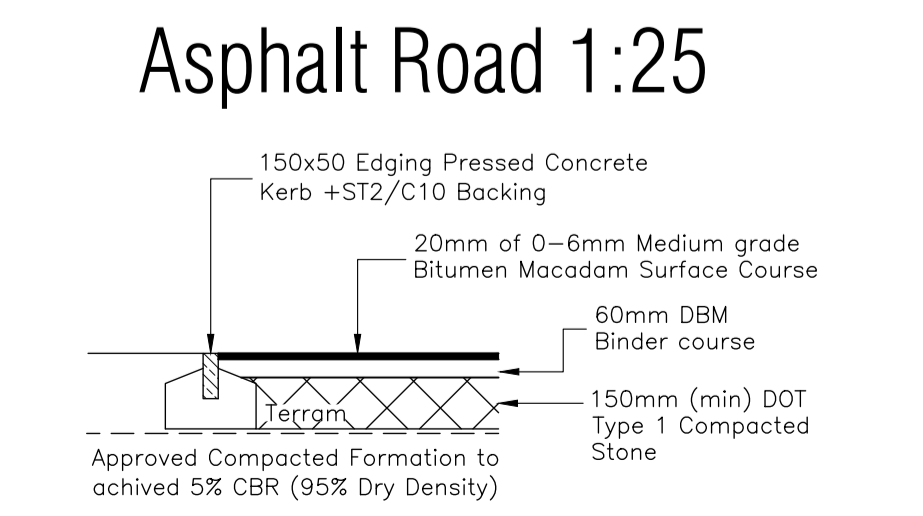

- NOTES**
- This drawing is to be read in conjunction with all relevant Architects and Bailey Johnson Hayes drawings and specifications.
  - Do not scale. Work only to figured dimensions.
  - All dimensions to be confirmed on site prior to commencement of work.
  - Proposed Site and Finishes Plan from Cornish Architects:- Drawing Ref: 22011 - TP - 001 - E
  - Topographical Survey by MK Surveys Limited: Drawing Ref: 25646 (Rev 1) - Topographical Survey
  - Soft Landscaping and planting to be as per Reform (Phase 1) and Laird Bailey (Phases 2) plans and schedules.

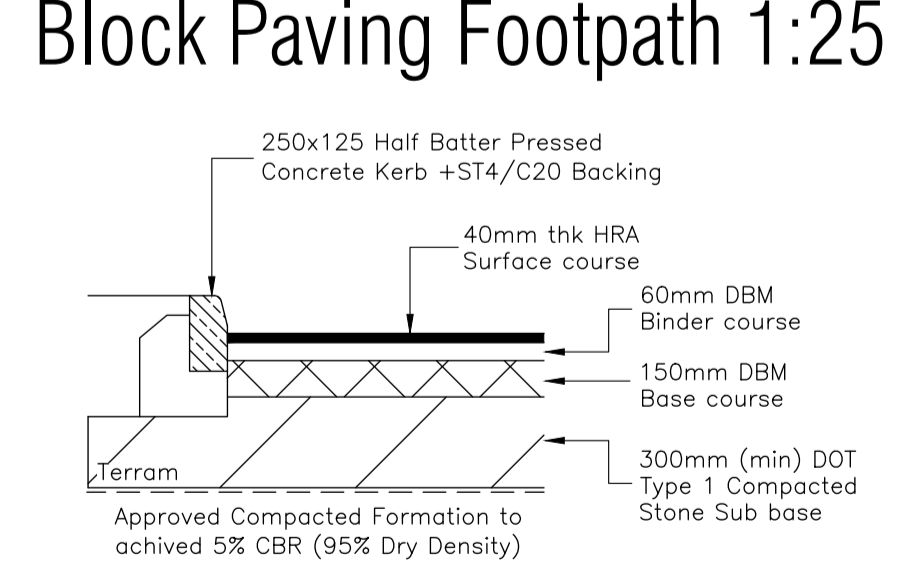
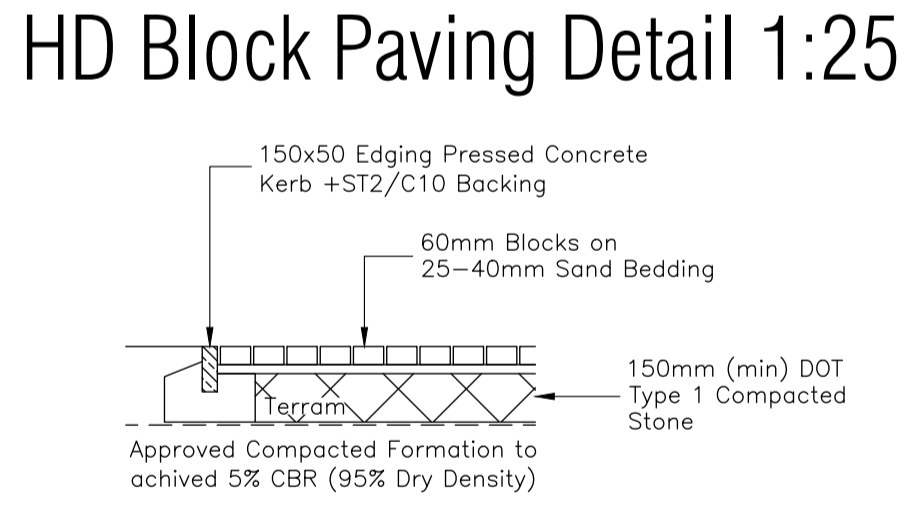
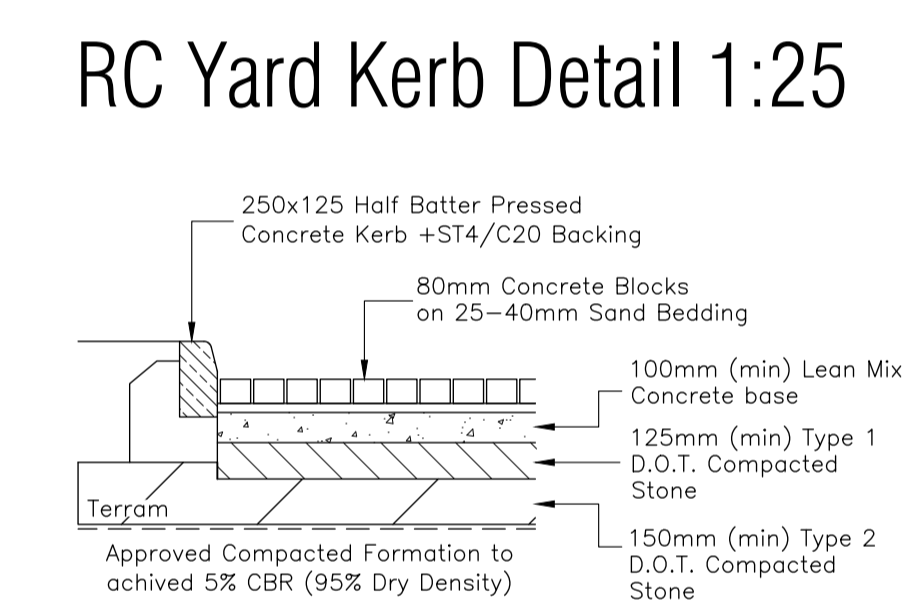
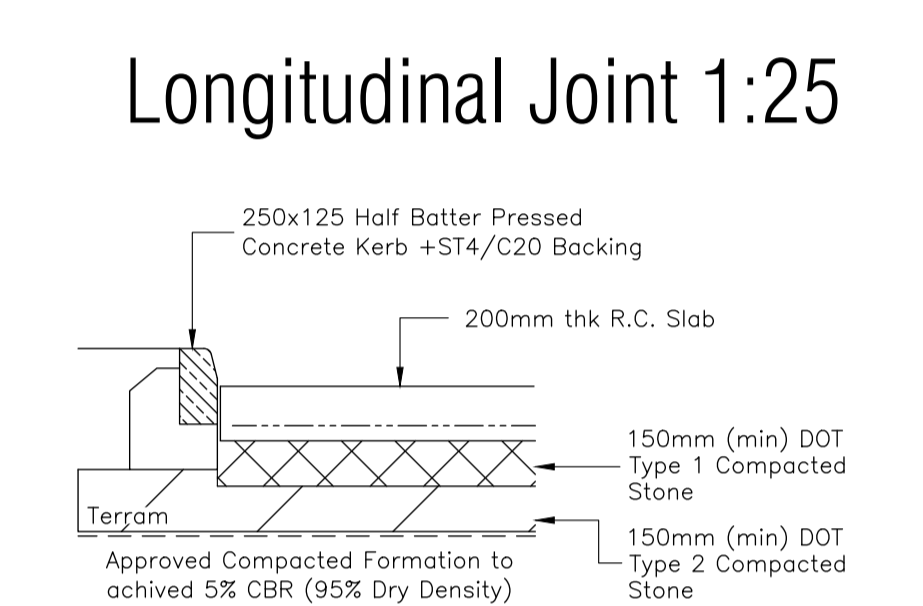
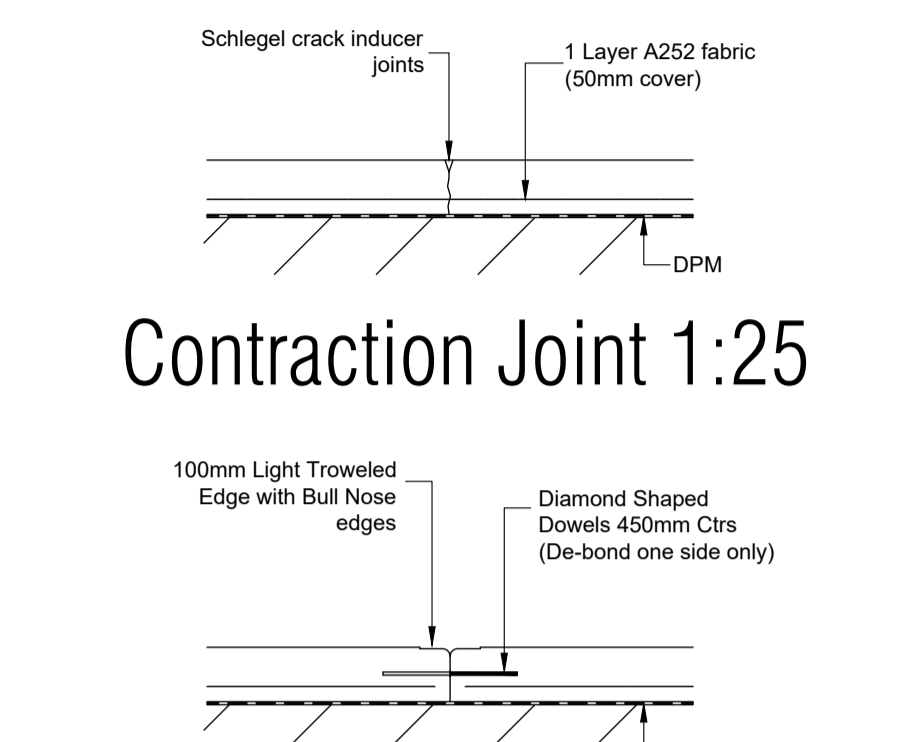
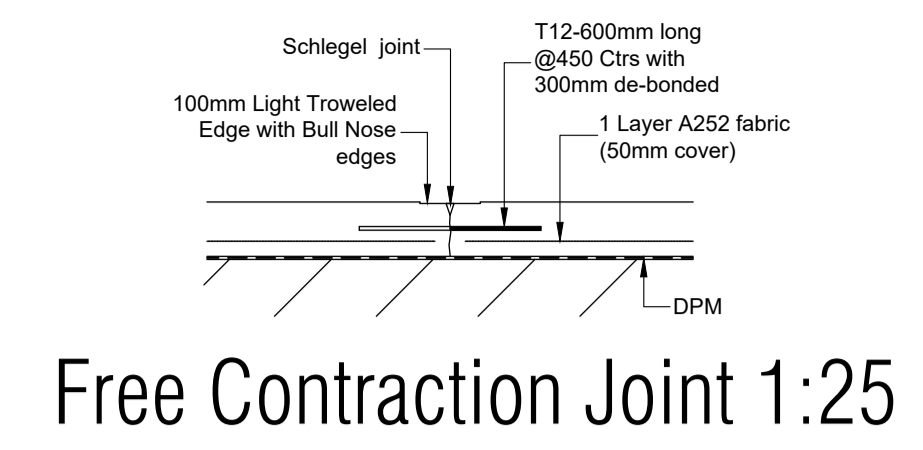
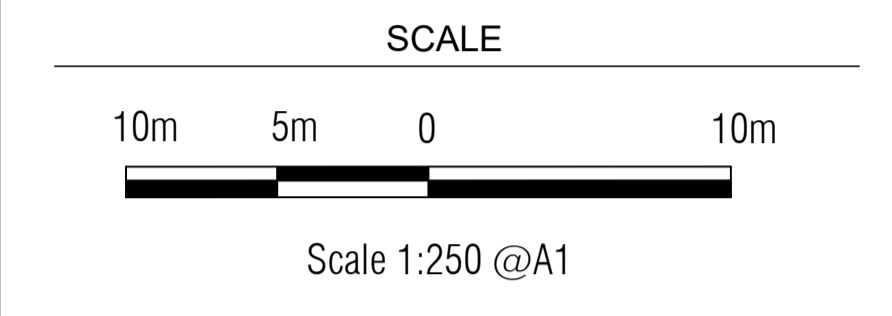

- LEGEND**
- New Office/Production Building
  - 200mm thk RC Yard Slab
  - 80mm HD Block Paving
  - 80mm Permeable Block Paving
  - 60mm Footpath Block Paving
  - Asphalt Estate Road
  - Bitmac Footways

Permeable Block Carpark 1:25

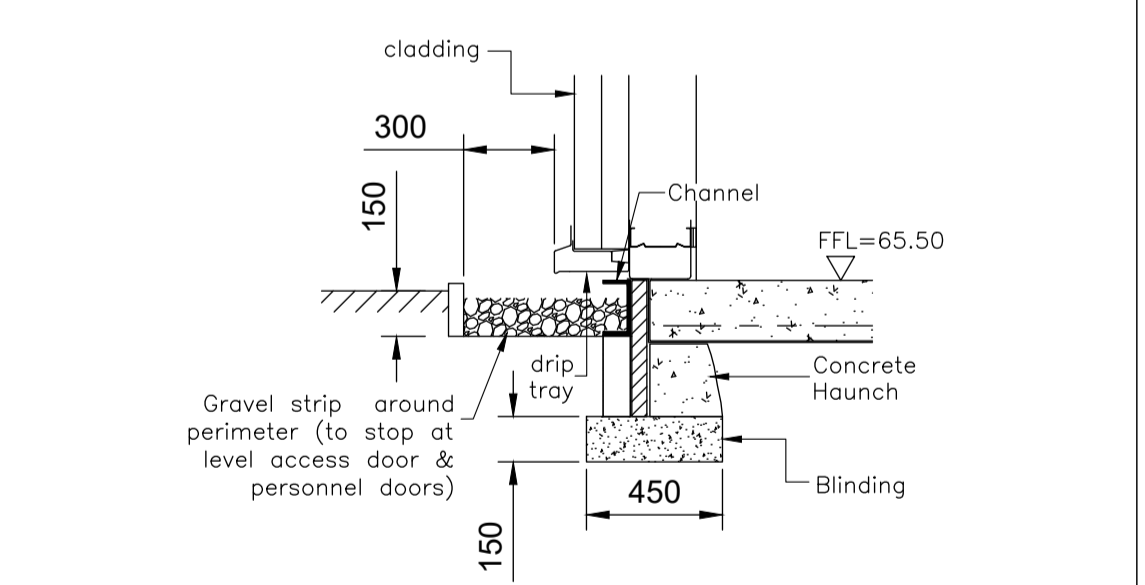

Gravel Strip Detail 1:25

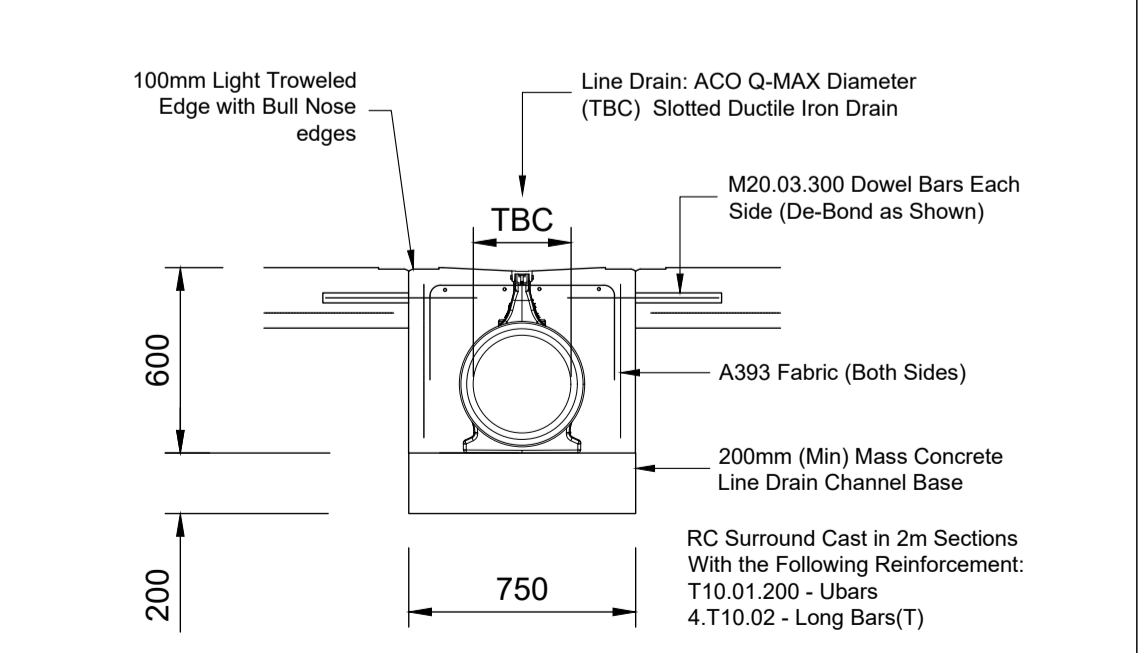

ACO Qmax Detail 1:25

**TOWN PLANNING**

B	17.01.23	Minor Revs to LLFA comments
A	10.01.23	Issued for Tender
Rev	Date	Revision Description

**Revision Schedule**

Project Title  
**Catalyst Bicester**  
Wendlebury Road, Bicester



Drawing Title  
**PHASE 2**  
Unit 6 External Works

**BAILEY JOHNSON HAYES**  
Consulting Engineers

ST ALBANS: Suite 4, Phoenix House, 63 Campfield Rd, ST ALBANS, Herts AL1 5FL  
MANCHESTER: Grange House, John Dalton Street, MANCHESTER, M2 6FW

Scale	1:250 @A1	Drawing Number	S1358-PH2-06 B
Date	24.11.22		
Drawn	DC		