

Unit 8+9 External Works Layout 1:250

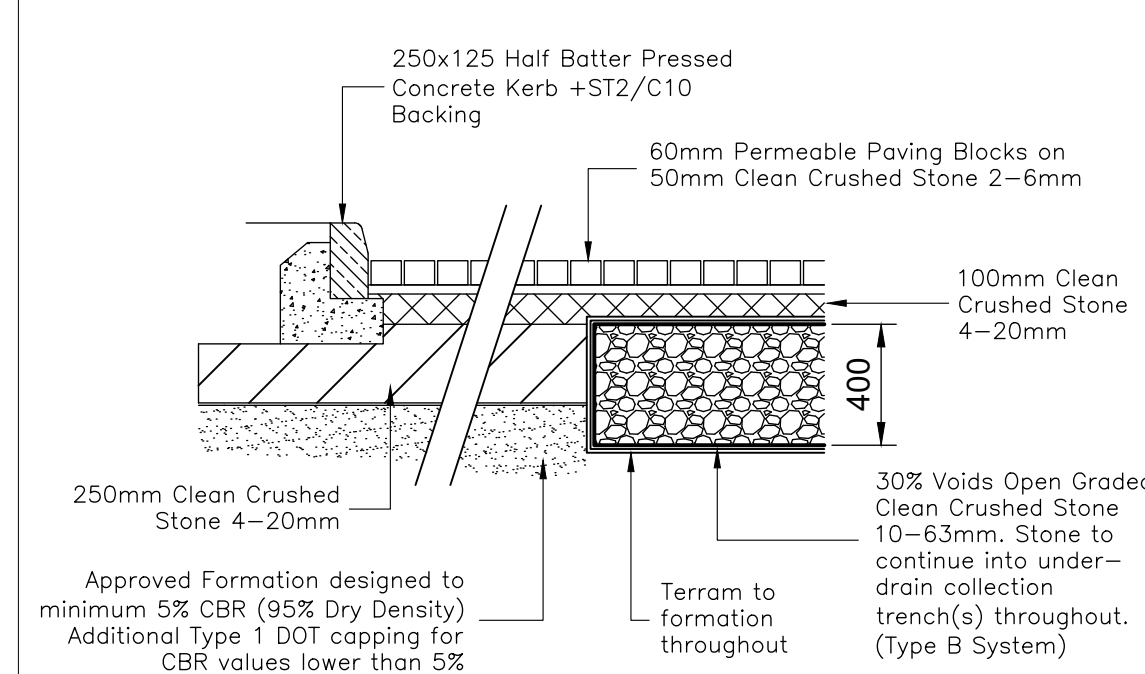

Permeable Block Carpark 1:25

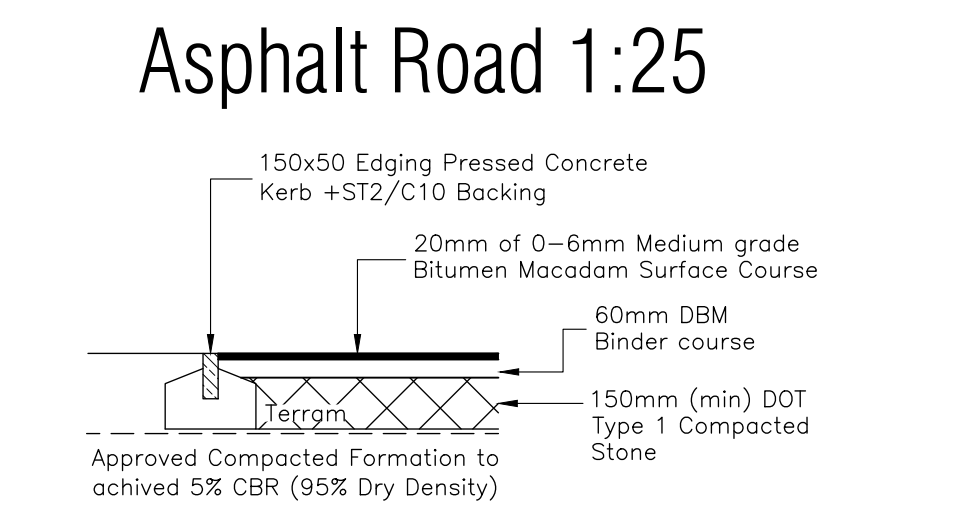
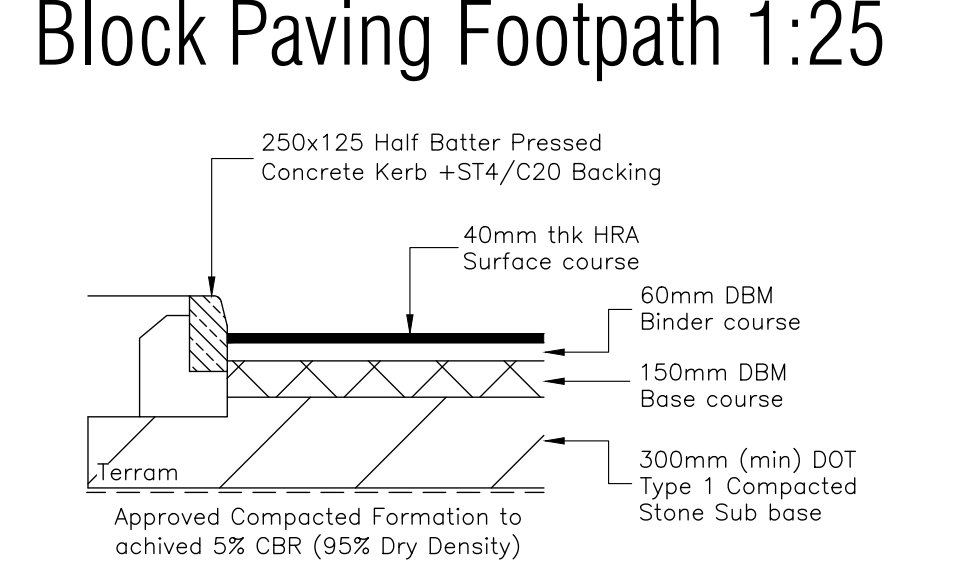
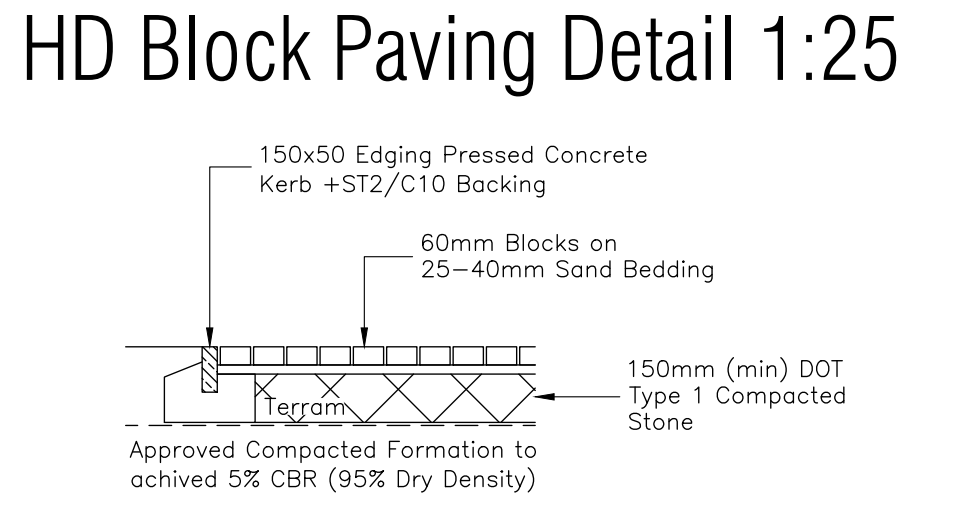
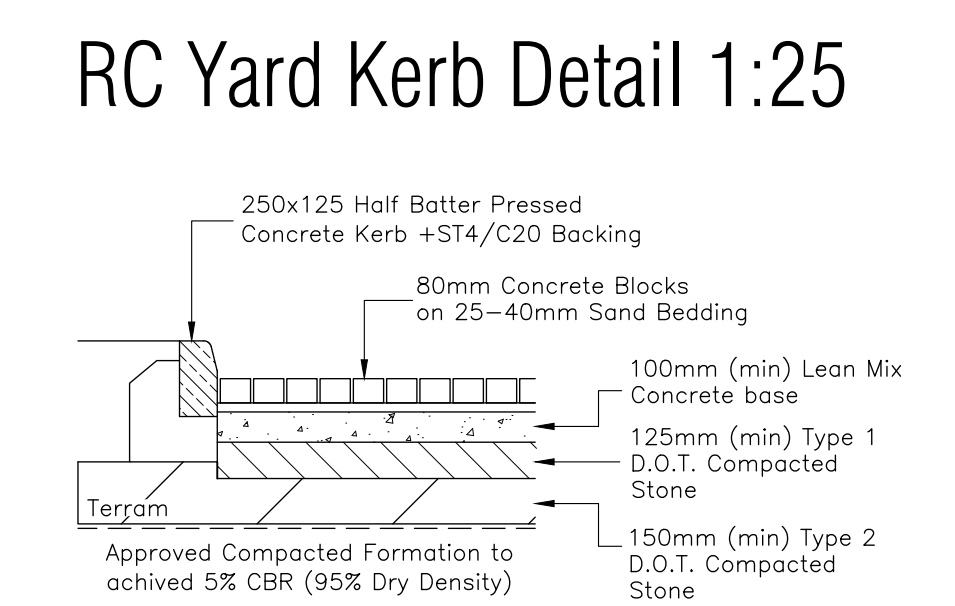
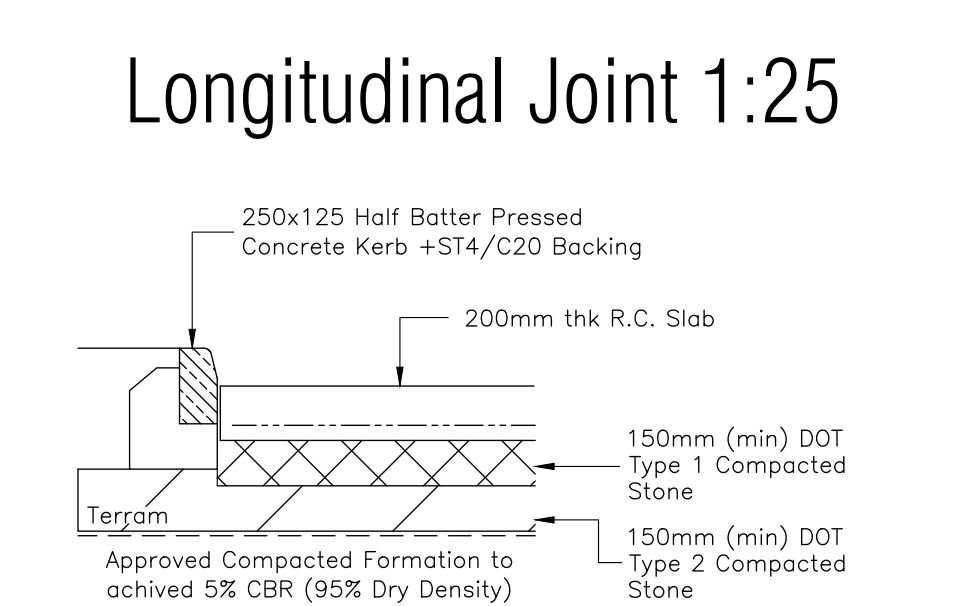
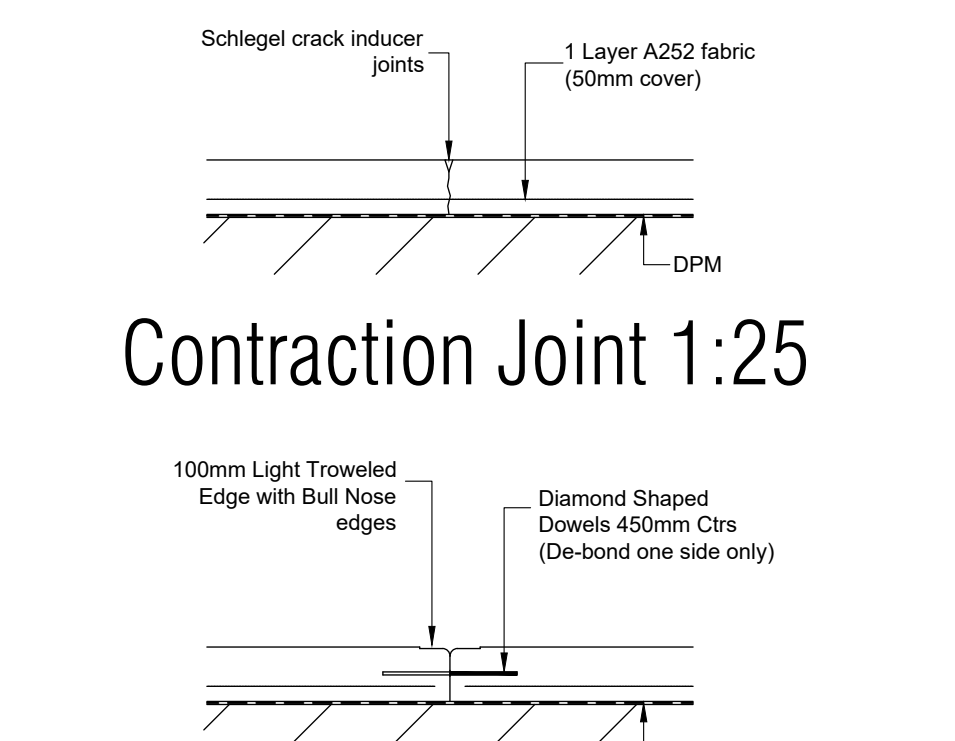
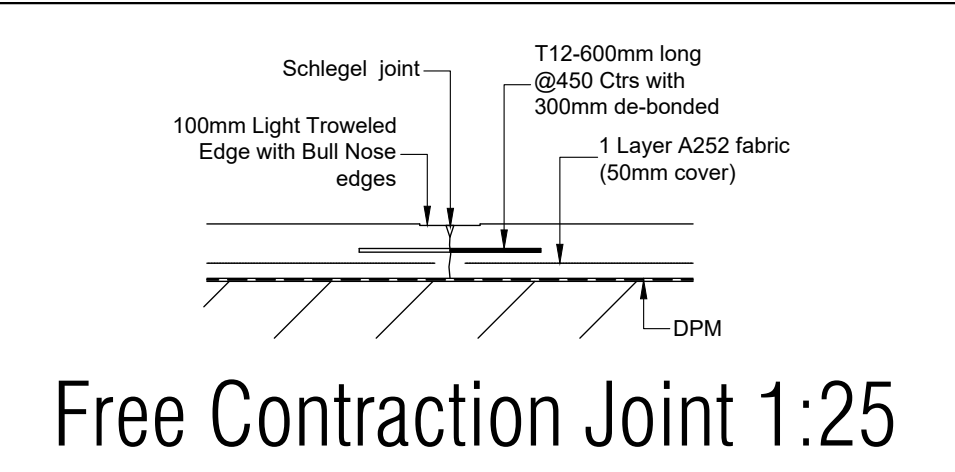
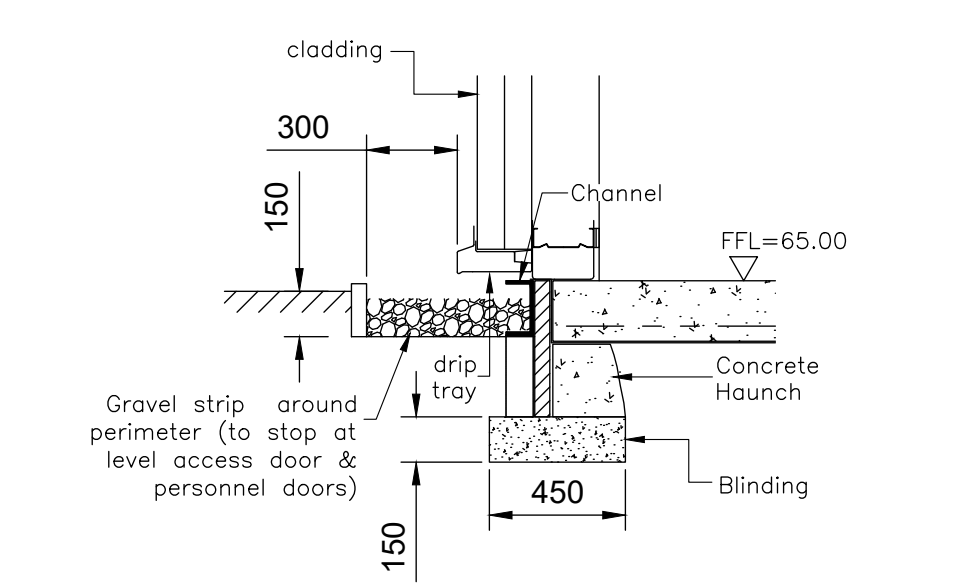

Gravel Strip Detail 1:25

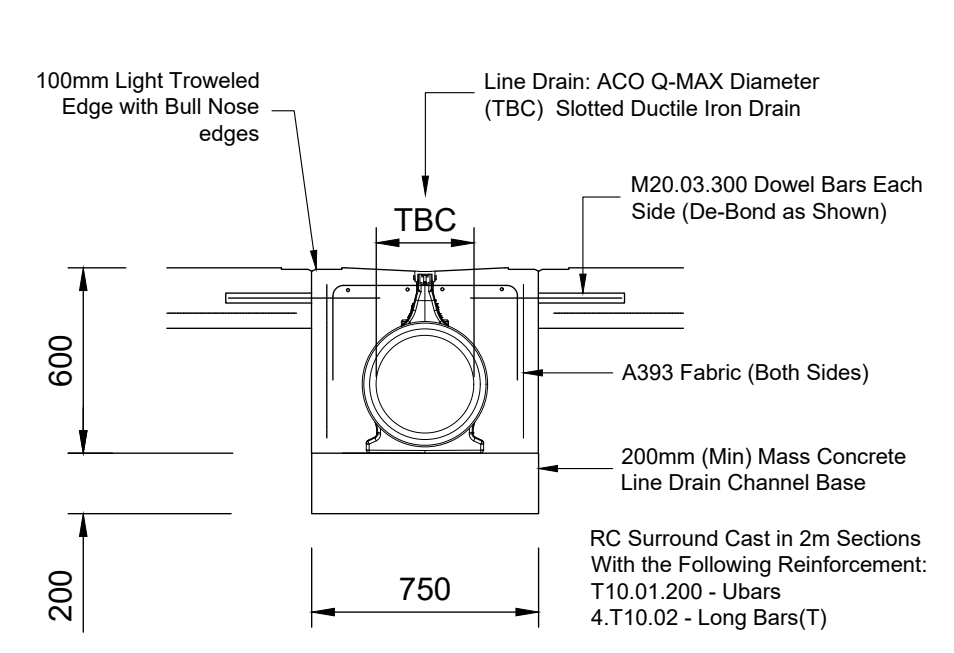

ACO Qmax Detail 1:25

- NOTES**
- This drawing is to be read in conjunction with all relevant Architects and Bailey Johnson Hayes drawings and specifications.
 - Do not scale. Work only to figured dimensions.
 - All dimensions to be confirmed on site prior to commencement of work.
 - Proposed Site and Finishes Plan from Cornish Architects:- Drawing Ref: 22011 - TP - 001 - E
 - Topographical Survey by MK Surveys Limited: Drawing Ref: 25646 (Rev 1) - Topographical Survey
 - Soft Landscaping and planting to be as per Reform (Phase 1) and Laird Bailey (Phases 2&3) plans and schedules.

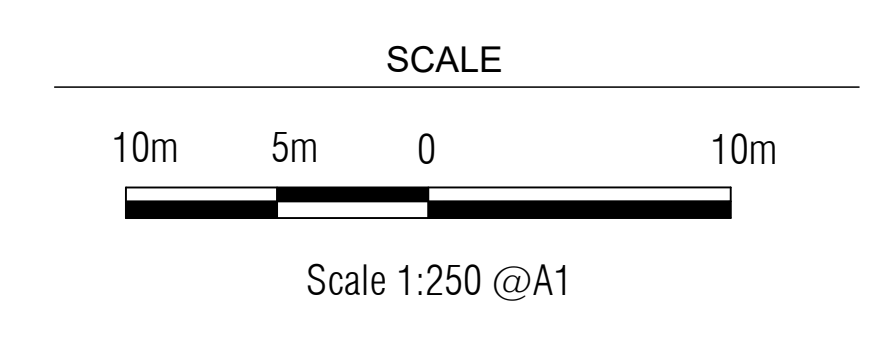

- LEGEND**
- New Office/Production Building
 - 200mm thk RC Yard Slab
 - 80mm HD Block Paving
 - 60mm Permeable Block Paving
 - 60mm Footpath Block Paving
 - Asphalt Estate Road
 - Bitmac Footways

TOWN PLANNING

Rev	Date	Revision Description

Revision Schedule

Project Title
Catalyst Bicester
Wendlebury Road, Bicester



Drawing Title
PHASE 2
Unit 8-9 External Works

BAILEY JOHNSON HAYES
Consulting Engineers

ST ALBANS: Suite 4, Phoenix House, 63 Campfield Rd, ST ALBANS, Herts AL1 5FL
MANCHESTER: Grange House, John Dalton Street, MANCHESTER, M2 6FW

Scale: 1:250 @A1
Date: 24.11.22
Drawn: DC

Drawing Number: S1358-PH2-10