

GENERAL NOTES

- THIS DRAWING IS TO BE READ IN CONJUNCTION WITH ALL GENERAL ARRANGEMENT AND PROJECT DETAILS DRAWINGS.
- UNLESS NOTED OTHERWISE, ALL DIMENSIONS ARE TO STRUCTURAL FACES AND/OR PARTITION STUDS.
- ABBREVIATIONS USED:-
 EMJ EXTERNAL MOVEMENT JOINT
 HL AT HIGH LEVEL
 AAV AIR ADMITTANCE VALVE
 SVP SOIL AND VENT PIPE
 DP DRAINAGE POINT
 RWP RAIN WATER PIPE
 CJ CONSTRUCTION JOINT
- LEGEND
 [Symbol] FACING BRICKWORK / RENDER FINISH ON 7.2N BLOCKWORK
 [Symbol] ENGINEERING BRICKWORK IN LINE WITH STRUCTURAL ENGINEERS SPECIFICATION
 [Symbol] 3.6N/50. MM AIRCRETE BLOCK (550 - 650 KG/M³) TO CLIENTS SPECIFICATION. BLOCK STRENGTH TO BE IN ACCORDANCE WITH THE STRUCTURAL ENGINEERS DETAILS. PARTY WALL IN ACCORDANCE WITH ROBUST DETAIL E-WM-30.
 [Symbol] NON-LOADBEARING PARTITION AS FOLLOWS:
 70MM GYPFRAME 'C' STUDS WITH 12.5 MM PLASTER BOARD. MOISTURE RESISTANT BOARD TO BE USED IN WET AREAS. PLY INFILL BETWEEN STUDS TO BE USED TO SUPPORT RADIATORS / KITCHEN WALL UNITS ALL IN ACCORDANCE WITH THE CLIENTS SPECIFICATION AND DETAIL.
 25MM ISOVER APR 1200 IN THE STUD CAVITY OR EQUIVALENT APPROVED MATERIAL (TO CLIENT SPECIFICATION) TO ALL BATHROOMS AND BETWEEN BEDROOMS / LIVING SPACES AS INDICATED
 [Symbol] 12 MM PLY FOR SANITARYWARE BASINS AND W/C'S INCLUDING BOXING, STUD WALLS AND BUTTRESS WALLS AS INDICATED
 [Symbol] BUTTRESS WALLS REQUIRE 12MM PLY LINING TO ONE SIDE AS STRUCTURAL ENGINEER'S DETAILS
 [Symbol] DENOTES SPAN OF FLOOR OVER (TYPE STATED)
 B&B BEAM & BLOCK
 TJ JOIST SPAN
 T TRUSS
- [Symbol] SB DENOTES STRUCTURAL BEAM OVER FOR ALL STRUCTURAL STEELWORK, PADSTONES, AND MOVEMENT JOINT DETAILS REFER TO THE STRUCTURAL ENGINEER'S DRAWINGS.
- ALL DRAINAGE RUNS TO BE ABOVE FLOOR UNLESS STATED OTHERWISE.
- ALL KITCHEN LAYOUTS TO SPECIALIST'S DESIGN AND DETAILS
- CONTINUOUS MECHANICAL EXTRACTS
 ALL EXTRACT DUCTS TO BE WITHIN THE FLOOR / ROOF SPACE UNLESS NOTED OTHERWISE, REFER TO SPECIALIST'S DRAWINGS FOR DETAILS
 [Symbol] INDICATES EXTRACT LOCATION
- [Symbol] DENOTES SMOKE ALARM - TO BE SELF CONTAINED, MAINS FED & INTERCONNECTED, TO COMPLY WITH B.S. 5446 PART 1.
 [Symbol] HEAT DETECTOR A100 EI 144 WITH BATTERY BACK UP
- FOR MOVEMENT JOINT, BED JOINT REINFORCEMENT AND ALL STRUCTURAL INFORMATION REFER TO STRUCTURAL ENGINEERS DRAWINGS AND DETAILS
- ALL SVP'S TO BE INSULATED WITH MIN 25MM INSULATION QUILT AND TO BE BOXED IN WITH 25X50 SW TIMBER BATTEN FRAMEWORK AND 2ND LAYERS OF 12.5MM PLASTERBOARD.

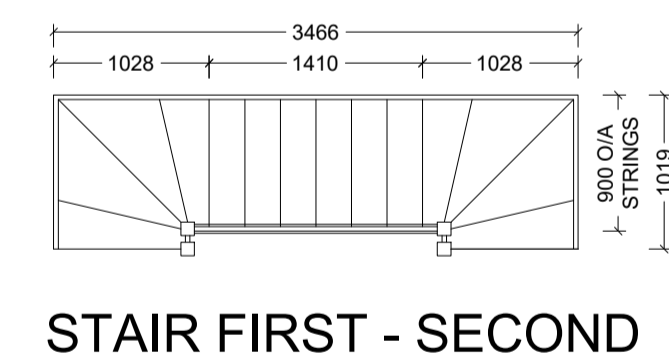

STAIR FIRST - SECOND

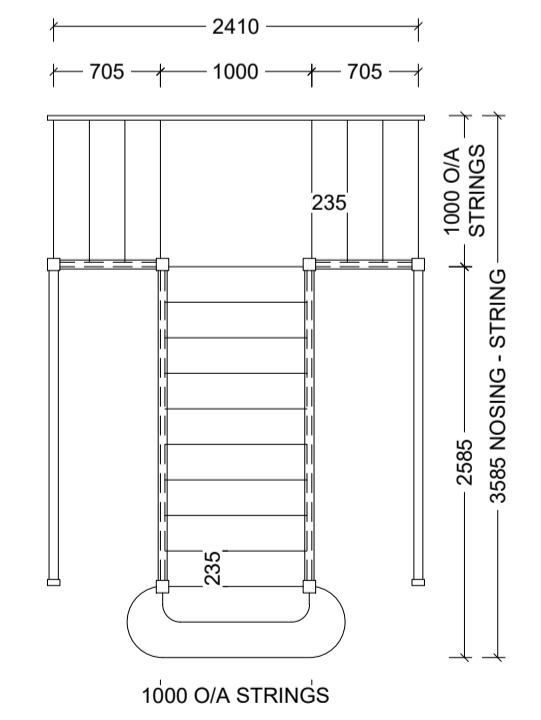

STAIR GROUND - FIRST

TIMBER STAIRCASE	
GROUND - FIRST FLOOR	FIRST - SECOND FLOOR
3275mm Total Rise	2935mm Total Rise
16 X 204.6mm Risers	15 X 195.6mm Risers
15 X 235mm Goings (Min.)	14 X 235mm Goings (Min.)
PITCH 41°	PITCH 40°
OVERALL WIDTH 1000MM	OVERALL WIDTH 900MM

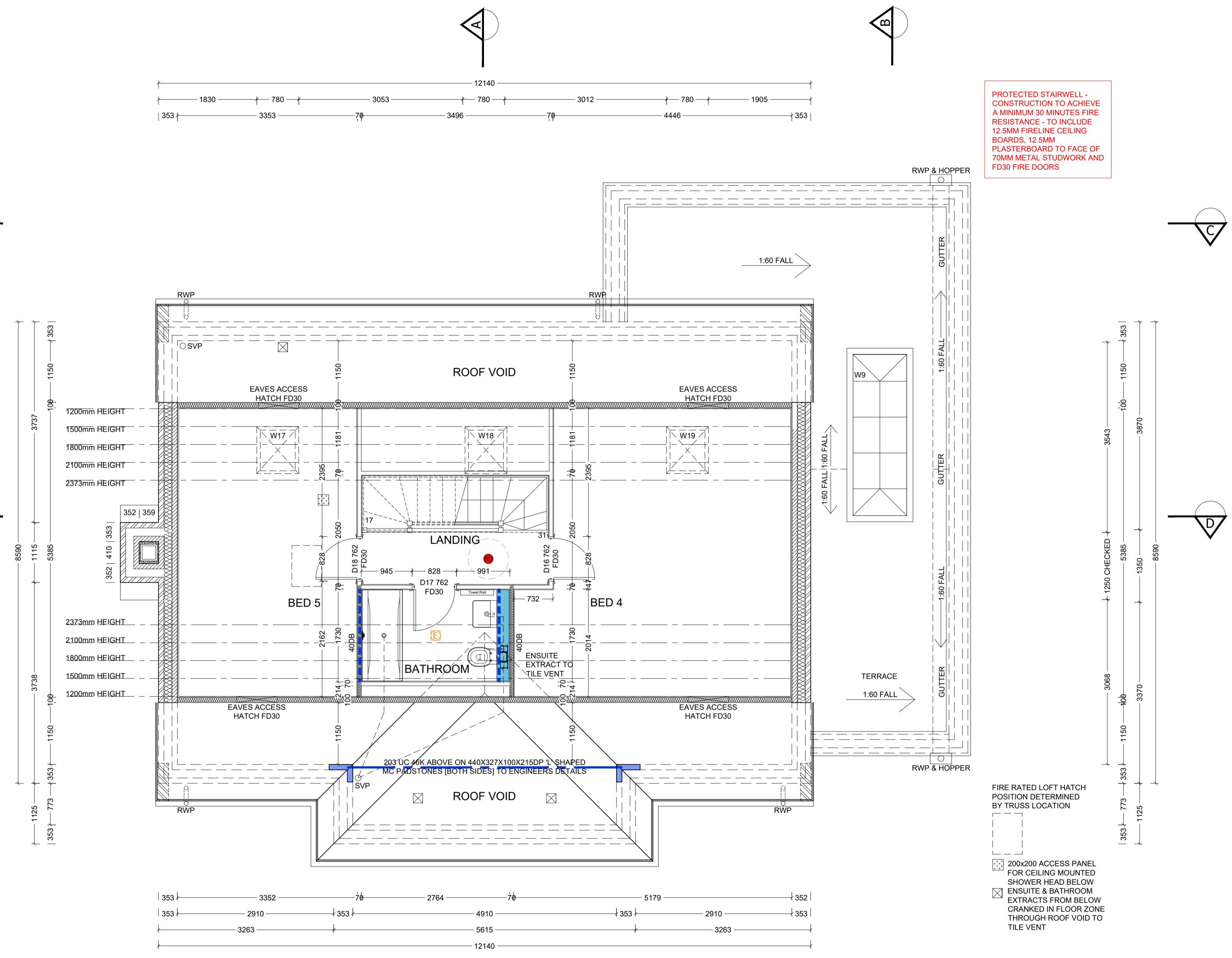

FIRST FLOOR PLAN

PROTECTED STAIRWELL - CONSTRUCTION TO ACHIEVE A MINIMUM 30 MINUTES FIRE RESISTANCE - TO INCLUDE 12.5MM FIRELINE CEILING BOARDS, 12.5MM PLASTERBOARD TO FACE OF 70MM METAL STUDWORK AND FD30 FIRE DOORS

Revision	Date	Description	By
P1	20.05.22	Preliminary Issue	MJR
P2	23.09.22	Main house foot print increased chimney re-centred side windows omitted, minor adjustments to internal rooms	MJR

A1 SHEET

BLOCKWORK STRENGTH
 7.2N GROUND - FIRST
 7.2N FIRST - SECOND
 3.6N SECOND - ROOF

REFER TO DRAWING
 HT5-09-05 FOR SCHEDULES

AREA SCHEDULE				
REF /	NET AREA		GROSS AREA	
	m ²	ft ²	m ²	ft ²
GROUND FLOOR	124.24	1337.30	125.70	1353.02
FIRST FLOOR	88.97	957.66	89.97	968.42
SECOND FLOOR	47.92	515.80	59.15	636.68
TOTAL	261.13	2810.76	274.82	2958.12

NET AREA = AREA MEASURED WITHIN THE BOUNDARY OF THE PLASTER FINISH TO EXTERNAL WALL AND SLOPING CEILINGS AT 1500MM ABOVE FFL.
 GROSS AREA = AREA MEASURED WITHIN THE BOUNDARY OF THE INNER STRUCTURAL FACE OF THE EXTERNAL WALL AND SLOPING CEILINGS AT 1200MM ABOVE FFL.

PHASE 9E PLOTS - (AS) 766,778,779 - (OPP) 765,770

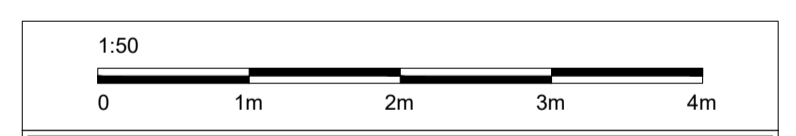

Site Address:
 UPPER HEYFORD, PHASE 9
 BICESTER

Drawing Title:
 HOUSE TYPE 5
 SECOND FLOOR PLAN

Scale: 1:50 @ A1 Date drawn: MAY 22 Drawn by: MJR

Project Number: 727 Drawing Number: HT5-09-03 Revision: P2

Status:
PRELIMINARY