

**DRAINAGE LAYOUT ACCESS ROAD  
1 IN 500 @ A3**

**NOTE:**

All work as per Oxordshire County Council highways department specification

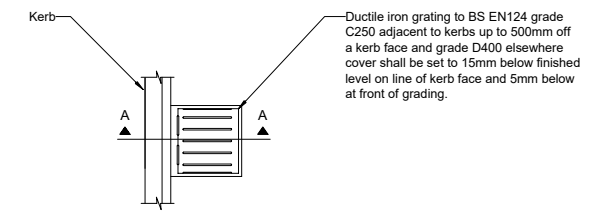

**PLAN**

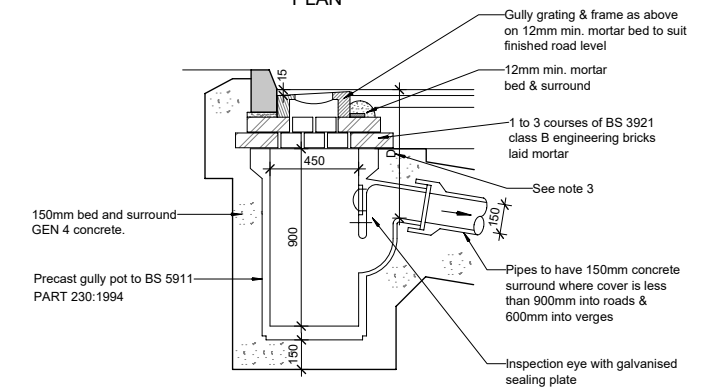

**SECTION A - A**

**8010 - Gully Detail - Concrete**

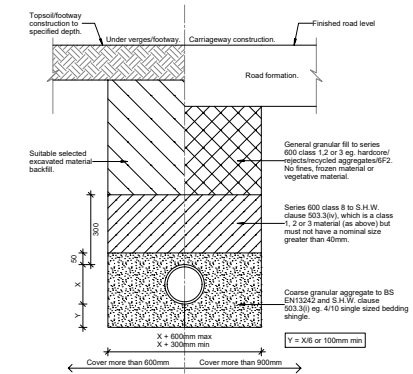

**Concrete Protection for Pipes Laid at Shallow Depths  
Cover < 600mm**

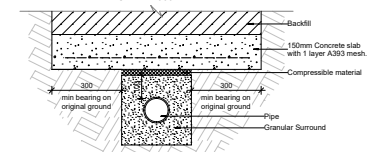

**8064 - Pipe Bedding Detail Type S**



**DRAINAGE LAYOUT AND DETAILS FOR  
MILTON ROAD DEVELOPMENT ACCESS ROAD  
1 IN 500 @ A3**

RIDA Reports Limited  
Bean Acre Road, Hook Norton  
Banbury OX15 5UA  
Telephone: 01608 510 121  
[www.rida-reports.co.uk](http://www.rida-reports.co.uk)