

**DRAINAGE LAYOUT ACCESS ROAD
1 IN 500 @ A3**

NOTE:

All work as per Oxordshire County Council highways department specification

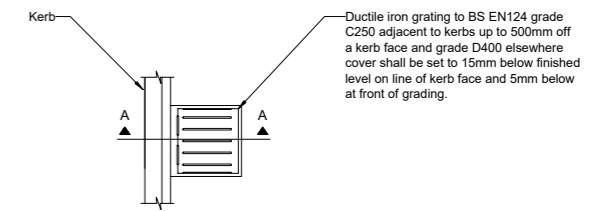

PLAN

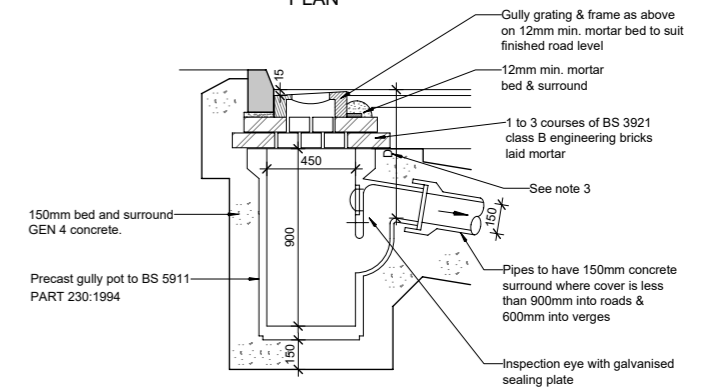

SECTION A - A

8010 - Gully Detail - Concrete

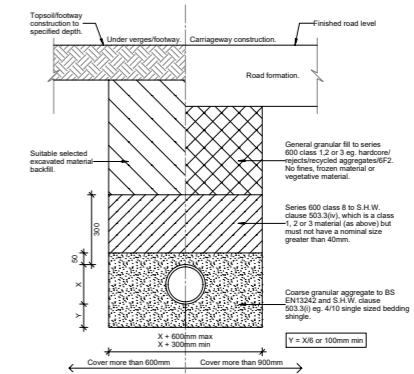

**Concrete Protection for Pipes Laid at Shallow Depths
Cover < 600mm**

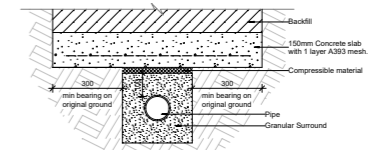

8064 - Pipe Bedding Detail Type S



**DRAINAGE LAYOUT AND DETAILS FOR
MILTON ROAD DEVELOPMENT ACCESS ROAD
1 IN 500 @ A3**

RIDA Reports Limited
Bean Acre Road, Hook Norton
Banbury OX15 5UA
Telephone: 01608 510 121
www.rida-reports.co.uk