

NOTES

1. All dimensions are in millimetres unless shown otherwise.
2. Dimensions of the concrete bed are the minimum required. Any overbreak of the excavation in width (shown as x) or in depth shall be filled with ST2 concrete when the bedding concrete is placed, trowel floated on top surface.
3. The existing carriageway shall be broken out as shown before the surface is reinstated in bituminous materials.
4. Kerbs shall be laid in accordance with clause 1101.

K1 kerb shown but detail is applicable to all kerb types.

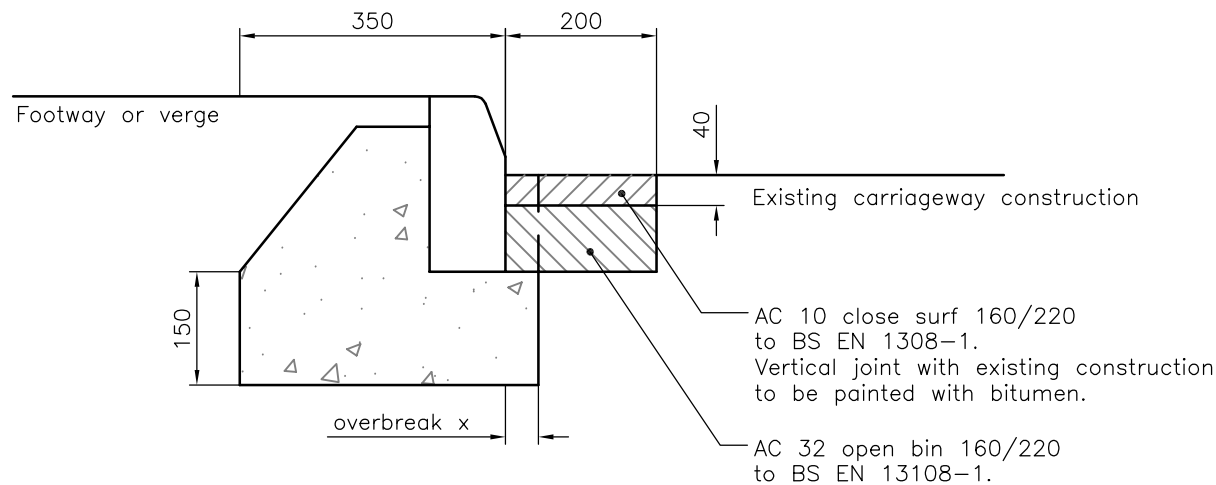

Reinstatement Detail for Kerbs  
Laid at the Edge of Existing Carriageway



Kerbs, Footways and Paved Areas

© Unauthorised reproduction infringes copyright

SCALE

Not to Scale

INITIALS

RVA

ALB

AMM

DATE

01.2006

01.2006

4.2007

INDEX

—

DRAWING No.

SECOND ISSUE

AMENDMENT

HSD/1100/139

10.05.08

DATE

CATEGORY

1