

ATTACHMENT H

ROAD SAFETY ASSESSMENT

Road Safety Assessment

**A4095 Howes Lane, junction with Bucknell Road,
Bicester**

Conversion of Junction to a Mini Roundabout

Date: 17/03/2022

Report produced for: Velocity Transport Planning

Report produced by: Kevin Seymour, Road Safety Consulting Ltd

Reference: RSC/KS/EB/21095

Document Control Sheet

Project Title A4095 Howes Lane, junction with Bucknell Road, Bicester
Conversion of Junction to a Mini Roundabout

Report Title Road Safety Assessment
Reference: RSC/KS/EB/21095

Revision -

Status Draft

Control Date 17/03/2022

Record of Issue

Issue	Author	Date	Check	Date	Authorised	Date
Draft	KS	16/03/22	EB	17/03/22	KS	17/03/22

Distribution

Organisation	Contact	Copies
Velocity Transport Planning	Mark Kirby	ecopy

Road Safety Consulting Ltd
4 Paramore Close
Whetstone
Leicestershire
LE8 6EY
Registered in England and Wales
Company Number 5225549

1. Introduction

1.1. Project Brief & Background

- 1.1.1. As part of the proposed development for up to 530 residential units on land on the north-west side of Bicester, there is a proposal to convert the existing give way controlled tee junction at the A4095 Howes Lane junction with Bucknell Road, Bicester, to a three armed mini roundabout. Road Safety Consulting Ltd has been commissioned to assess the road safety implications associated with the existing layout and proposed conversion of the junction, to inform the designer and client on the relative merits and risks of the proposed conversion.
- 1.1.2. The conversion of this junction is being proposed as a result of Oxfordshire County Council's decision to redirect the previously agreed funding for the Approved A4095 Strategic Link Road (14/01968/F). As such, the proposed Interim Improvement (i.e., the conversion of the A4095 Howes Lane/Bucknell Road junction to a mini roundabout) is proposed to accommodate all of the development traffic associated with the full Firethorn Development prior to the implementation of the A4095 Strategic Link Road.
- 1.1.3. The access to the proposed residential development is to be taken from the as-built estate road that runs from a priority junction with the B4100 to the south-east of the proposed development with Charlotte Avenue to a priority junction to the north-east of the proposed development with Braeburn Avenue.
- 1.1.4. A Bus Only link is located between the Eastern and Western Parcels of the proposed development. Two site access junctions will be formed to the south of the bus gate and one new site access junction to be formed to the north of the bus gate. A new extended access road is to be provided on the northern boundary of the western parcel of the proposed development. A temporary access is proposed to access the Eastern Parcel of land from the B4100 during construction only and a temporary access is proposed to the Western Parcel from the existing layby on the B4100 Banbury Road during construction only.

1.2. Outline of Methodology

- 1.2.1. This safety assessment has been carried out by comparing road safety issues associated with the layout of the existing junction form with the aid of the reported road traffic collision record for the junction, with the possible road safety related issues associated with the proposed conversion of the junction to a mini roundabout. This comparative assessment is qualitative in nature and specific to this particular change in junction form.
- 1.2.2. The road safety issues have been identified with both layouts and a discussion on the benefits / disbenefits of the proposed conversion of junction form carried, with final concluding remarks.

2. The Existing Junction

2.1. Junction Layout

- 2.1.1. Currently, the junction of the A4095 Howes Lane with Bucknell Road is a three-armed give way controlled tee junction. This section of the highway network is subject to a posted speed limit of 30mph and street lighting is present.
- 2.1.2. Howes Lane has a two lane give way line and the approach has a series of horizontal curves on the eastbound approach to the junction; this reduces forward visibility to the junction area, but there appears to be adequate stopping sight distance along Howes Lane, towards the junction, consistent with the posted speed limit. This approach is on a slight downhill gradient towards the junction. There is an existing map type direction sign on the immediate approach to the junction.
- 2.1.3. On Howes Lane, approximately 40m west of the junction with Bucknell Road, there is a bridleway, to the north of the road and equestrians were observed to be using Howes Lane and Bucknell Road during the site visit.



- 2.1.4. Bucknell Road (southern arm), is on a straight alignment and there is a TRIEF kerbed traffic island approximately 40m from the centre of the junction. There is a continuous hatched marking separator strip; the strip appears to have been highlighted with red surfacing in the past, although this is faded. The hatched area extends through the junction, to provide a narrow, 1m wide, right turn area for users wishing to turn from Bucknell Road on to Howes Lane. This hatched area does not allow right turning vehicles to clear the through lane, and this led to some, minimal, queuing at the junction in the off-peak site visit period.



- 2.1.5. Bucknell Road (northern arm), is at the southbound exit from an adjacent small conventional roundabout; the junction of Bucknell Road with the A4095 Lords Lane, and the roundabout exit is approximately 40m from the centre of the junction with Howes Lane. There is an uncontrolled pedestrian crossing, on Bucknell Road, just north of the Howes Lane junction; this crossing forms a link to the nearby footpath, which links with an adjacent residential development. There are map type direction signs on both the A4095 Lords Lane and Bucknell Road (N) approaches to the roundabout.



A4095 Howes Lane, junction with Bucknell Road, Bicester
Conversion of Junction to a Mini Roundabout



2.2. Traffic Flow Data

2.2.1. Peak hour traffic flow data has been provided to the assessment team, for both existing (2022) conditions and projected (2028) conditions, with possible development traffic added. This data is shown, in diagrammatic form below.

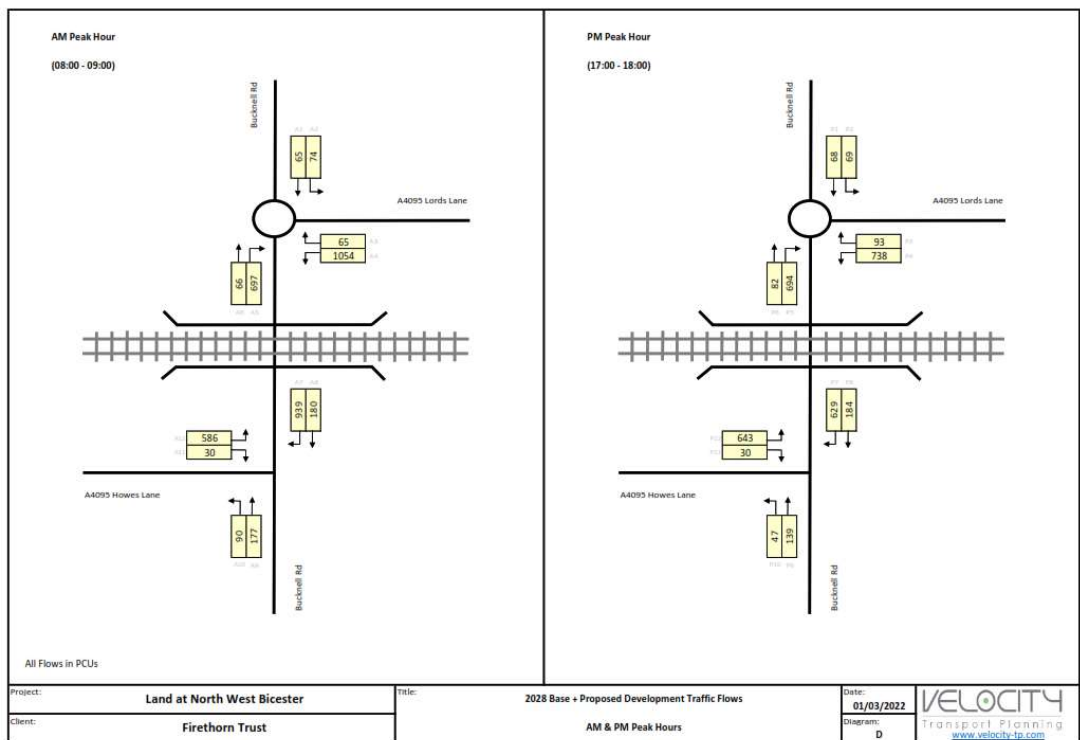
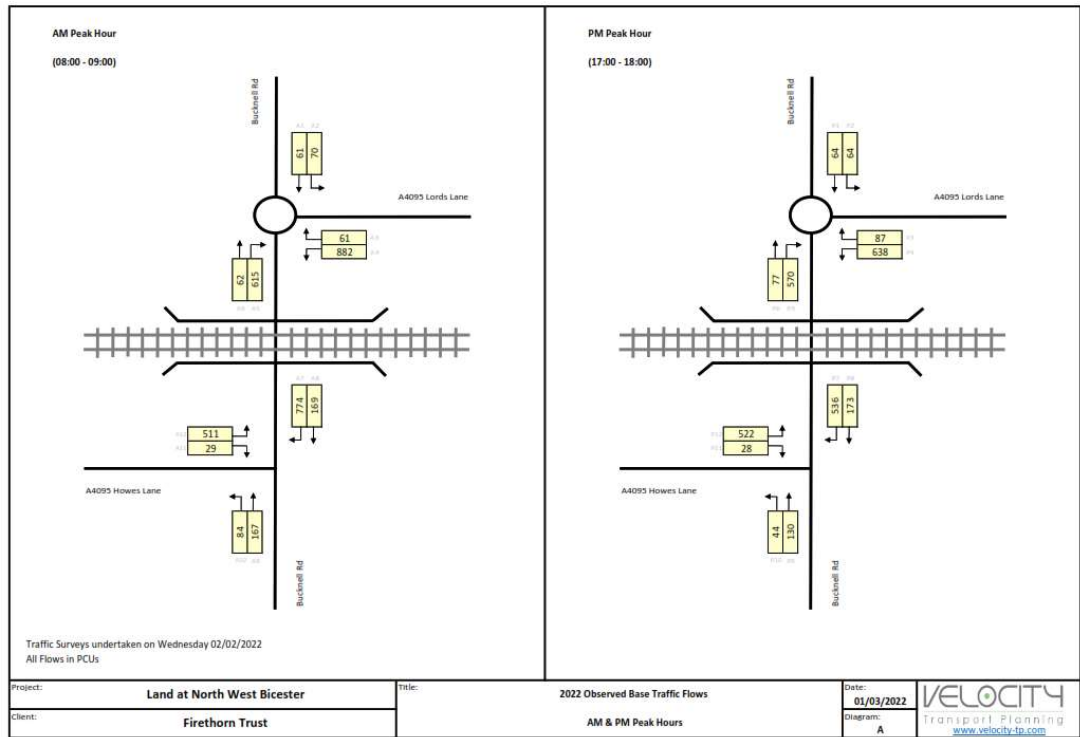

2.2.2. The traffic flow data indicates that the predominant traffic flows at the junction are:

- The left turn manoeuvre from Howes Lane to Bucknell Road, and
- The right turn manoeuvre from Bucknell Road to Howes Lane.

- 2.2.3. The traffic flow data also indicates that in the AM peak hour the increase in traffic at the junction will be 15.5% (from 1744 vehicles in 2022, to 2002 by 2028 with development) and 16.7% in the pm peak hours (from 1433 in 2022, to 1672 in 2028 with development).
- 2.2.4. Whilst capacity modelling information has not been provided to the assessment team, it can be seen that the turning traffic proportions would indicate that the current junction priorities do not reflect the predominant traffic movements and queuing at the junction (particularly for the right turn manoeuvre from Bucknell Road) is likely at peak times with increased traffic volumes associated with the proposed development.
- 2.2.5. No vehicle speed information has been made available to the assessment team, however, the proximity of the Lords Lane roundabout to the Howes Lane junction is likely to result in low approach vehicle speeds.

2.3. Road Traffic Collision History

- 2.3.1. Road traffic collision data has been provided to the assessment team for the five year period 01/01/2016 and 31/12/2021. This data indicates that there have been no reported injury collisions at the Howes Lane junction, nor the roundabout junction with Bucknell Road with the A4095 in that period.
- 2.3.2. One injury collision occurred on the A4095 Lords Lane, approximately 50m from the roundabout junction. This collision appears to be related to a medical episode and not related to the highway layout at this location.

2.4. Road Safety Related Issues of the Existing Layout

- 2.4.1. Notwithstanding the absence of reported road traffic collisions, there are a number of potential road safety related issues associated with the existing layout; these are outlined below and are associated with both the existing traffic flow conditions and in future traffic flow scenarios with the proposed development.
- 2.4.2. On Bucknell Road (N), at the uncontrolled pedestrian crossing, inter-visibility between pedestrians crossing from the western footway and drivers turning left from Howes Lane is restricted by the railway bridge wing wall. At the time of the site visit traffic flows were such that it was difficult to assess a safe gap for pedestrians to make the crossing; it is likely that during peak traffic periods assessing safe gaps is likely to be more problematic. Additional traffic volumes associated with the proposed development is likely to exacerbate the issue.
- 2.4.3. On Bucknell Road (N), the right turn manoeuvre to Howes Lane is the predominant traffic flow at present, this is reflected in the traffic flow data provide above. There is a short stacking space between the right turn area and the exit of the Lords Lane roundabout. It is likely that occasionally queuing vehicles may exceed this stacking space, which may lead to blocking of the roundabout junction. Queuing vehicles within the roundabout junction area may increase the risk of collisions involving unexpected lane change or filtering manoeuvres, particularly involving two-wheeled users. Additional traffic volumes associated with the proposed development is likely to exacerbate the issue.
- 2.4.4. With the current collision record, the apparent road safety issues have not led to reported road traffic collisions, however increased traffic volumes, and possible increases in pedestrian movements associated with the proposed development may increase the likelihood of the road safety related hazards maturing into reported collisions. The increase in traffic volumes will increase exposure to risk, however there is no clear calculable method of identifying whether the increase in exposure to risk will mature into injury collisions.

3. The Proposed Junction

3.1. Junction Layout

- 3.1.1. The proposal to convert the give way controlled tee junction has been triggered by Oxfordshire County Council's decision to redirect the previously agreed funding for the Approved A4095 Strategic Link Road (14/01968/F). As such, the proposed Interim Improvement (i.e. the conversion of the A4095 Howes Lane/Bucknell Road junction to a mini roundabout) is proposed to accommodate all of the development traffic associated with the full Firethorn Development prior to the implementation of the A4095 Strategic Link Road.

- 3.1.2. The proposed mini roundabout junction layout has been subject to a Stage 1 Road Safety Audit (RSA) (audit reference RSC/KS/EB/21093). This audit raised six road safety related issues, with associated recommendations to mitigate these issues. This report should be read in conjunction with the Stage 1 RSA report and the issues identified within the Stage 1 RSA will not be repeated within this report.

3.2. Mini Roundabout Road Safety

- 3.2.1. TRL research report TRL 281 – Accidents at Urban Mini Roundabouts indicates that three arm mini roundabouts have similar mean collision rates to three arm priority T-junctions and up to 30% fewer collisions than for signalled junctions. This research (confirmed by DfT Mini Roundabout Good Practice Guidance – 2006) also indicates that the severity of collisions (percentage of fatal and serious collisions to all injury accidents) at three arm mini-roundabout sites is lower than at three arm signalled junctions and considerably lower than at 30 mph T-junctions.
- 3.2.2. The same research also indicates that at three arm sites 39.9% of injury collisions involved two wheeled users; the majority of these were of the entering/circulating type. Research from TfL indicates, that in London, 37% of collisions at priority junctions involved two-wheeled users, compared to 33% for mini roundabouts – “Levels of Risk in Greater London, issue 13, TfL 2012.

4. Discussion and Conclusions

4.1. Discussion

- 4.1.1. According to DfT / County Surveyors document “Mini Roundabout Good Practice Guidance” the introduction of a three arm mini roundabout can improve the operation of a junction by:
- **Reducing the dominance of one traffic flow**
As the mini-roundabout works on the principle of ‘priority to circulating traffic from the right,’ a minor traffic flow can be given priority over a major traffic flow that would otherwise dominate the junction.
 - **Giving priority to right turners**
Again the ‘priority’ principle of operation has been exploited for right-turning traffic, giving it priority over ahead movements from the opposing direction.
 - **Facilitating access and reducing delay at side roads**
The ‘priority to the right’ rule effectively halves the traffic to which side road flow has to yield priority, making it easier for side road traffic to turn.
 - **Improving capacity at overloaded junctions**
For a given road space, the mini-roundabout has a higher capacity than most alternatives and is very flexible in coping with variations in both volumes and proportions of traffic flow during the day.
- 4.1.2. Additionally, the injury collision rates for mini roundabouts are generally similar to urban T-junctions, and show lower severity of injury when compared with urban T-junctions. Mini roundabouts are generally believed to have high proportions of collisions involving two-wheeled users, although this is likely to be layout dependent and figures from TfL show mixed outcomes, and in Greater London the proportions of two-wheeled user involvement for the two junction types is similar.
- 4.1.3. At the specific location in question, i.e. the junction of A4095 Howes Lane, there have been no recorded injury collisions in the past five years. Whilst no vehicle speed information has been made available to the assessment team, the proximity of the Lords Lane roundabout to the study junction is likely to result in low approach vehicle speeds and this may be contributing to the good collision record history and continue to assist in reducing collision risk with the introduction of a mini roundabout.
- 4.1.4. From a road safety related point of view, there are potential road safety related issues associated with the proposed mini roundabout layout, as highlighted within the Stage 1 Road Safety Audit, although the design is likely to be amenable to amendment to overcome the issues directly related to the proposed junction conversion.
- 4.1.5. There are pedestrian safety issues associated with both the existing and proposed layouts, specifically, restricted inter-visibility at the uncontrolled crossing of the northern arm of Bucknell Road. The lack of any injury collisions involving pedestrians at this location at present, may be a result of low pedestrian crossing volumes. The proposed layout is unlikely to improve conditions for pedestrians at the junction, particularly with increased traffic volumes, as well as possible increased pedestrian activity. Any increase in traffic flows will increase the exposure to risk for

vulnerable users, therefore there may be a need to introduce measures to improve the pedestrian crossing environment; the Stage 1 RSA has recommended improvement measures.

- 4.1.6. At the Howes Lane junction, the predominant turning movement are the left turn from Howes Lane to Bucknell Road northern arm and the reverse right turn movement from Bucknell Road in to Howes Lane. The introduction of a mini roundabout junction would provide a level of priority for the right turn manoeuvre in to Howes Lane and this is likely to be beneficial in reducing the possibility of junction blocking at the adjacent Lords Lane roundabout.

4.2. Conclusions

- 4.2.1. The existing T-junction layout exhibits a good road safety record, with no reported road traffic collisions in the past five year period.
- 4.2.2. The conversion of the existing junction to a mini roundabout is unlikely to materially adversely affect road safety at the junction, with collision control data indicating similar collision rates between T-junctions and mini roundabouts, and with the proportion of serious injuries being less with mini roundabouts.
- 4.2.3. Some research has indicated that mini roundabouts tend to have higher portions of collisions involving two-wheeled users than T-junctions, although control data from TfL shows similar proportions of two-wheeled users involvement with the different junction types.
- 4.2.4. With the absence of strong evidence to rule out the conversion of the junction to a mini roundabout, there are some benefits in such a conversion, and these are associated with traffic capacity improvements and introducing priority for right turning movements from Bucknell Road, which would assist in capacity improvement and play a part in reducing potential junction blocking at the Lords Lane roundabout, which would in turn reduce the likelihood of collisions associated with such junction blocking.
- 4.2.5. Overall, the conversion of the existing T-junction would provide positive impacts in terms of traffic capacity, to enable a level of residential development to be implemented. Any adverse effects that may be associated with such a conversion are questionable and appear to be able to be mitigated by a 'best practice' design of the three armed mini roundabout.
- 4.2.6. One issue that should be carefully considered when converting the junction form would be pedestrian safety and amenity at the junction. This is clearly an issue with the current T-junction layout and improved provision, as recommended with the Stage 1 RSA, would mitigate an existing issue and provide a more 'pedestrian friendly' crossing environment with the proposed converted layout.

Safety Assessors

Kevin Seymour, B Sc, PG Dip TS, MCIHT, MSoRSA

Signed:  Date: 16th March 2022

Elaine Bingham, BEng (Hons), MCIHT, MSoRSA

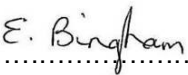
Signed:  Date: 17th March 2022

Road Safety Consulting Ltd
4 Paramore Close
Whetstone
Leicestershire
LE8 6EY

APPENDIX 1: Existing and Proposed Junction Layouts

Existing Layout

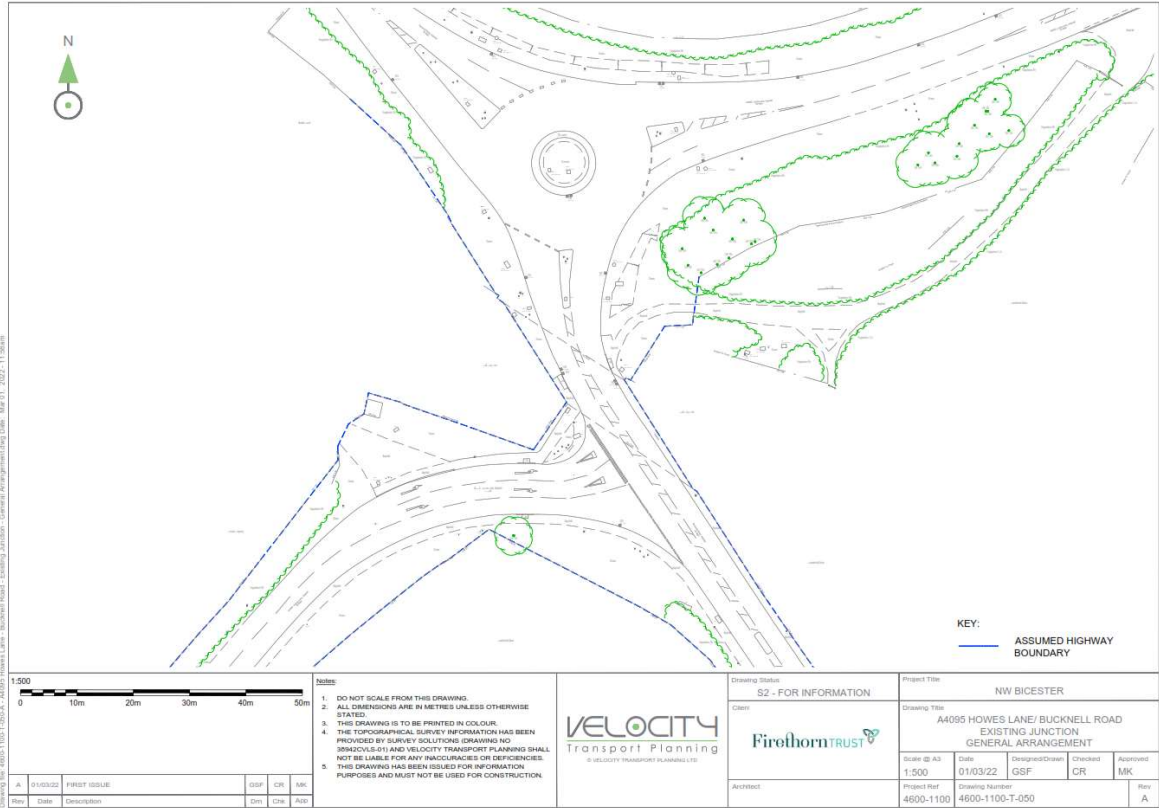

Proposed Layout

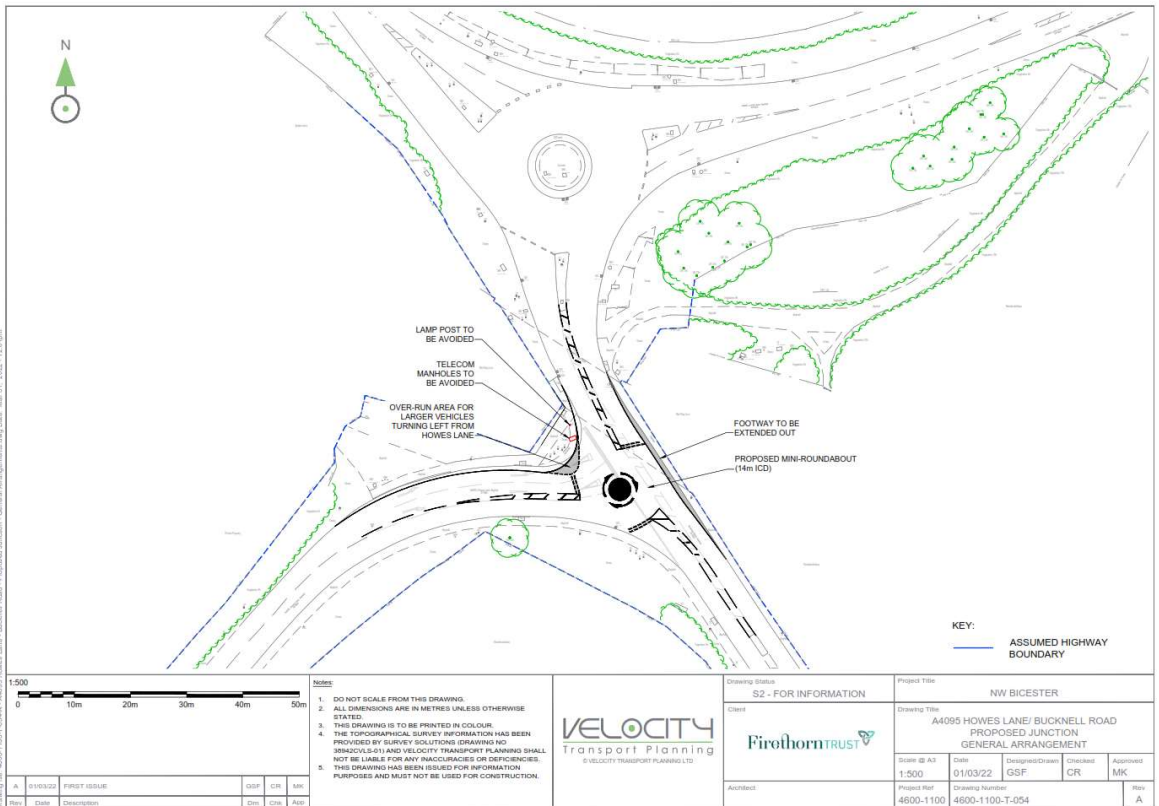

ATTACHMENT I

PROPOSED MINI-ROUNDBOUT JUNCTION PARAMETERS

Drawing file: 4600-1100-T-060-A - A4095 Howes Lane - Bucknell Road - Proposed Junction - General Arrangement Measurements.dwg Date: Mar 15, 2022 - 12:20pm

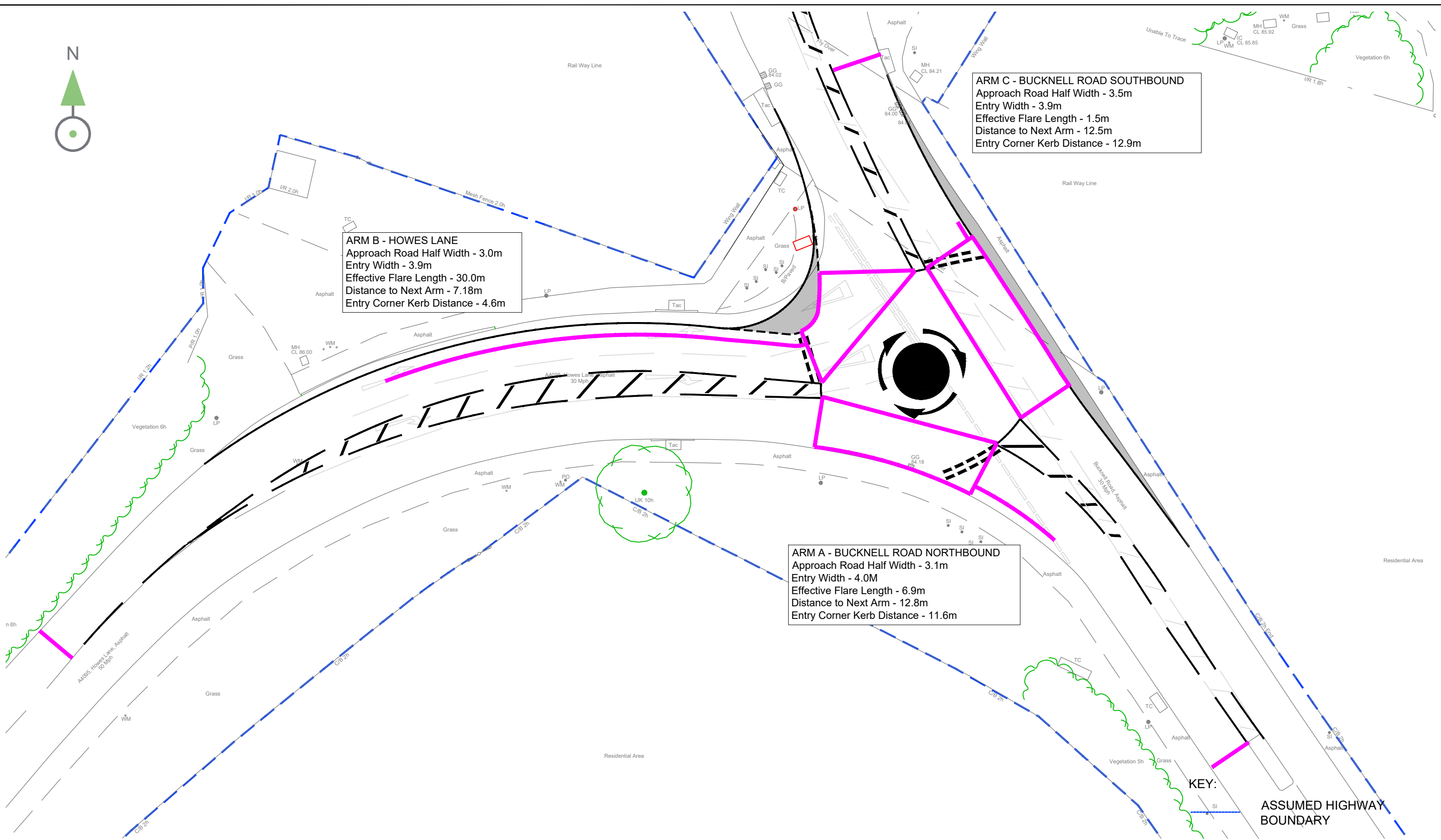

ARM B - HOWES LANE
 Approach Road Half Width - 3.0m
 Entry Width - 3.9m
 Effective Flare Length - 30.0m
 Distance to Next Arm - 7.18m
 Entry Corner Kerb Distance - 4.6m

ARM C - BUCKNELL ROAD SOUTHBOUND
 Approach Road Half Width - 3.5m
 Entry Width - 3.9m
 Effective Flare Length - 1.5m
 Distance to Next Arm - 12.5m
 Entry Corner Kerb Distance - 12.9m

ARM A - BUCKNELL ROAD NORTHBOUND
 Approach Road Half Width - 3.1m
 Entry Width - 4.0m
 Effective Flare Length - 6.9m
 Distance to Next Arm - 12.8m
 Entry Corner Kerb Distance - 11.6m

KEY:
 --- ASSUMED HIGHWAY BOUNDARY



- Notes:**
- DO NOT SCALE FROM THIS DRAWING.
 - ALL DIMENSIONS ARE IN METRES UNLESS OTHERWISE STATED.
 - THIS DRAWING IS TO BE PRINTED IN COLOUR.
 - THE TOPOGRAPHICAL SURVEY INFORMATION HAS BEEN PROVIDED BY SURVEY SOLUTIONS (DRAWING NO 38942CVLS-01) AND VELOCITY TRANSPORT PLANNING SHALL NOT BE LIABLE FOR ANY INACCURACIES OR DEFICIENCIES.
 - THIS DRAWING HAS BEEN ISSUED FOR INFORMATION PURPOSES AND MUST NOT BE USED FOR CONSTRUCTION.



Drawing Status
S2 - FOR INFORMATION



Client
 Architect

Project Title
NW BICESTER

Drawing Title
A4095 HOWES LANE/ BUCKNELL ROAD PROPOSED JUNCTION GENERAL ARRANGEMENT - MEASUREMENTS

Scale @ A3 1:500	Date 15/03/22	Designed/Drawn GSF	Checked CR	Approved MK
---------------------	------------------	-----------------------	---------------	----------------

Project Ref 4600-1100	Drawing Number 4600-1100-T-060	Rev A
--------------------------	-----------------------------------	----------

Rev	Date	Description	Drn	Chk	App
A	15/03/22	FIRST ISSUE	GSF	CR	MK

ATTACHMENT J

PROPOSED MINI-ROUNDBOUT JUNCTION – JUNCTIONS 10 OUTPUT FILES

Junctions 10
ARCADY 10 - Roundabout Module
Version: 10.0.3.1598 © Copyright TRL Software Limited, 2021
For sales and distribution information, program advice and maintenance, contact TRL Software: +44 (0)1344 379777 software@trl.co.uk trlsoftware.com
The users of this computer program for the solution of an engineering problem are in no way relieved of their responsibility for the correctness of the solution

Filename: 2022.03.14 - NW BICESTER - HOWES LANE (Mini RbT Mitigation).j10
Path: P:\Firethorn Trust_4600\1100 - NW Bicester\Analysis\Modelling\Picady\BTM 2026 FLOWS
Report generation date: 23/03/2022 15:21:26

- »BTM Base 2026, AM
- »BTM Base 2026, PM
- »BTM 2026 + Proposed Development, AM
- »BTM 2026 + Proposed Development, PM

Summary of junction performance

	AM						PM					
	Set ID	Queue (PCU)	Delay (s)	RFC	LOS	Junction Delay (s)	Set ID	Queue (PCU)	Delay (s)	RFC	LOS	Junction Delay (s)
BTM Base 2026												
Arm A	D1	4.5	33.19	0.82	D	132.46	D2	1.9	12.62	0.64	B	349.63
Arm B		3.5	22.05	0.77	C			55.8	222.96	1.12	F	
Arm C		68.1	248.48	1.13	F			153.8	607.00	1.27	F	
BTM 2026 + Proposed Development												
Arm A	D3	5.0	37.25	0.84	E	309.47	D4	1.9	12.20	0.63	B	527.20
Arm B		4.9	29.15	0.83	D			105.7	472.77	1.25	F	
Arm C		149.5	591.54	1.27	F			208.4	807.01	1.34	F	

Values shown are the highest values encountered over all time segments. Delay is the maximum value of average delay per arriving vehicle. Junction LOS and Junction Delay are demand-weighted averages.

File summary

File Description

Title	(untitled)
Location	
Site number	
Date	02/11/2021
Version	
Status	(new file)
Identifier	
Client	
Jobnumber	
Enumerator	VTPI\CRicci
Description	

Units

Distance units	Speed units	Traffic units input	Traffic units results	Flow units	Average delay units	Total delay units	Rate of delay units
m	kph	PCU	PCU	perHour	s	-Min	perMin

Analysis Options

Mini-roundabout model	Calculate Queue Percentiles	Calculate residual capacity	RFC Threshold	Average Delay threshold (s)	Queue threshold (PCU)
JUNCTIONS 9			0.85	36.00	20.00

Demand Set Summary

ID	Scenario name	Time Period name	Traffic profile type	Start time (HH:mm)	Finish time (HH:mm)	Time segment length (min)
D1	BTM Base 2026	AM	ONE HOUR	07:45	09:15	15
D2	BTM Base 2026	PM	ONE HOUR	16:45	18:15	15
D3	BTM 2026 + Proposed Development	AM	ONE HOUR	07:45	09:15	15
D4	BTM 2026 + Proposed Development	PM	ONE HOUR	16:45	18:15	15

Analysis Set Details

ID	Network flow scaling factor (%)
At	100.000

BTM Base 2026, AM

Data Errors and Warnings

No errors or warnings

Junction Network

Junctions

Junction	Name	Junction type	Use circulating lanes	Arm order	Junction Delay (s)	Junction LOS
1	untitled	Mini-roundabout		A, B, C	132.46	F

Junction Network

Driving side	Lighting	Road surface	In London	Network delay (s)	Network LOS
Left	Normal/unknown	Normal/unknown		132.46	F

Arms

Arms

Arm	Name	Description
A	untitled	
B	untitled	
C	untitled	

Mini Roundabout Geometry

Arm	Approach road half-width (m)	Minimum approach road half-width (m)	Entry width (m)	Effective flare length (m)	Distance to next arm (m)	Entry corner kerb line distance (m)	Gradient over 50m (%)	Kerbed central island
A	3.10	3.10	4.00	6.9	12.80	11.60	0.0	
B	3.00	3.00	3.90	30.0	7.18	4.60	0.0	
C	3.50	3.50	3.60	1.5	12.50	12.90	0.0	

Slope / Intercept / Capacity

Roundabout Slope and Intercept used in model

Arm	Final slope	Final intercept (PCU/hr)
A	0.622	1078
B	0.621	972
C	0.621	904

The slope and intercept shown above include any corrections and adjustments.

Traffic Demand

Demand Set Details

ID	Scenario name	Time Period name	Traffic profile type	Start time (HH:mm)	Finish time (HH:mm)	Time segment length (min)
D1	BTM Base 2026	AM	ONE HOUR	07:45	09:15	15

Vehicle mix source	PCU Factor for a HV (PCU)
HV Percentages	2.00

Demand overview (Traffic)

Arm	Linked arm	Use O-D data	Average Demand (PCU/hr)	Scaling Factor (%)
A		✓	470	100.000
B		✓	539	100.000
C		✓	915	100.000

Origin-Destination Data

Demand (PCU/hr)

From	To		
	A	B	C
A	0	174	296
B	13	0	526
C	180	735	0

Vehicle Mix

Heavy Vehicle Percentages

From	To		
	A	B	C
A	0	10	10
B	10	0	10
C	10	10	0

Results

Results Summary for whole modelled period

Arm	Max RFC	Max Delay (s)	Max Queue (PCU)	Max LOS
A	0.82	33.19	4.5	D
B	0.77	22.05	3.5	C
C	1.13	248.48	68.1	F

Main Results for each time segment

07:45 - 08:00

Arm	Total Demand (PCU/hr)	Circulating flow (PCU/hr)	Capacity (PCU/hr)	RFC	Throughput (PCU/hr)	End queue (PCU)	Delay (s)	Unsignalised level of service
A	354	543	740	0.478	350	1.0	10.044	B
B	406	220	836	0.486	402	1.0	9.047	A
C	689	10	898	0.767	676	3.3	16.914	C

08:00 - 08:15

Arm	Total Demand (PCU/hr)	Circulating flow (PCU/hr)	Capacity (PCU/hr)	RFC	Throughput (PCU/hr)	End queue (PCU)	Delay (s)	Unsignalised level of service
A	423	645	677	0.624	419	1.8	15.204	C
B	485	264	808	0.599	482	1.6	12.056	B
C	823	12	897	0.917	803	8.3	35.901	E

08:15 - 08:30

Arm	Total Demand (PCU/hr)	Circulating flow (PCU/hr)	Capacity (PCU/hr)	RFC	Throughput (PCU/hr)	End queue (PCU)	Delay (s)	Unsignalised level of service
A	517	709	636	0.813	508	4.1	28.893	D
B	593	320	774	0.767	587	3.3	20.438	C
C	1007	14	895	1.125	883	39.4	112.013	F

08:30 - 08:45

Arm	Total Demand (PCU/hr)	Circulating flow (PCU/hr)	Capacity (PCU/hr)	RFC	Throughput (PCU/hr)	End queue (PCU)	Delay (s)	Unsignalised level of service
A	517	717	632	0.819	516	4.5	33.193	D
B	593	325	771	0.770	593	3.5	22.050	C
C	1007	14	895	1.125	893	68.1	227.823	F

08:45 - 09:00

Arm	Total Demand (PCU/hr)	Circulating flow (PCU/hr)	Capacity (PCU/hr)	RFC	Throughput (PCU/hr)	End queue (PCU)	Delay (s)	Unsignalised level of service
A	423	709	637	0.663	431	2.3	20.012	C
B	485	272	804	0.603	492	1.7	12.964	B
C	823	12	897	0.917	882	53.1	248.483	F

09:00 - 09:15

Arm	Total Demand (PCU/hr)	Circulating flow (PCU/hr)	Capacity (PCU/hr)	RFC	Throughput (PCU/hr)	End queue (PCU)	Delay (s)	Unsignalised level of service
A	354	706	639	0.554	357	1.4	14.242	B
B	406	225	833	0.487	408	1.1	9.392	A
C	689	10	898	0.767	879	5.7	128.057	F

BTM Base 2026, PM

Data Errors and Warnings

No errors or warnings

Junction Network

Junctions

Junction	Name	Junction type	Use circulating lanes	Arm order	Junction Delay (s)	Junction LOS
1	untitled	Mini-roundabout		A, B, C	349.63	F

Junction Network

Driving side	Lighting	Road surface	In London	Network delay (s)	Network LOS
Left	Normal/unknown	Normal/unknown		349.63	F

Traffic Demand

Demand Set Details

ID	Scenario name	Time Period name	Traffic profile type	Start time (HH:mm)	Finish time (HH:mm)	Time segment length (min)
D2	BTM Base 2026	PM	ONE HOUR	16:45	18:15	15

Vehicle mix source	PCU Factor for a HV (PCU)
HV Percentages	2.00

Demand overview (Traffic)

Arm	Linked arm	Use O-D data	Average Demand (PCU/hr)	Scaling Factor (%)
A		✓	504	100.000
B		✓	764	100.000
C		✓	1036	100.000

Origin-Destination Data

Demand (PCU/hr)

		To		
		A	B	C
From	A	0	178	326
	B	13	0	751
	C	646	390	0

Vehicle Mix

Heavy Vehicle Percentages

		To		
		A	B	C
From	A	0	10	10
	B	10	0	10
	C	10	10	0

Results

Results Summary for whole modelled period

Arm	Max RFC	Max Delay (s)	Max Queue (PCU)	Max LOS
A	0.64	12.62	1.9	B
B	1.12	222.96	55.8	F
C	1.27	607.00	153.8	F

Main Results for each time segment

16:45 - 17:00

Arm	Total Demand (PCU/hr)	Circulating flow (PCU/hr)	Capacity (PCU/hr)	RFC	Throughput (PCU/hr)	End queue (PCU)	Delay (s)	Unsignalised level of service
A	379	285	901	0.421	376	0.8	7.504	A
B	575	243	821	0.700	565	2.4	14.969	B
C	780	10	898	0.868	756	5.9	24.902	C

17:00 - 17:15

Arm	Total Demand (PCU/hr)	Circulating flow (PCU/hr)	Capacity (PCU/hr)	RFC	Throughput (PCU/hr)	End queue (PCU)	Delay (s)	Unsignalised level of service
A	453	326	875	0.518	452	1.2	9.321	A
B	687	292	791	0.868	673	5.8	30.559	D
C	931	11	897	1.038	867	21.9	72.622	F

17:15 - 17:30

Arm	Total Demand (PCU/hr)	Circulating flow (PCU/hr)	Capacity (PCU/hr)	RFC	Throughput (PCU/hr)	End queue (PCU)	Delay (s)	Unsignalised level of service
A	555	337	869	0.639	552	1.9	12.393	B
B	841	357	751	1.121	736	32.1	109.222	F
C	1141	13	896	1.273	894	83.5	223.987	F

17:30 - 17:45

Arm	Total Demand (PCU/hr)	Circulating flow (PCU/hr)	Capacity (PCU/hr)	RFC	Throughput (PCU/hr)	End queue (PCU)	Delay (s)	Unsignalised level of service
A	555	337	868	0.639	555	1.9	12.618	B
B	841	359	749	1.122	746	55.8	222.963	F
C	1141	13	896	1.273	896	144.8	467.059	F

17:45 - 18:00

Arm	Total Demand (PCU/hr)	Circulating flow (PCU/hr)	Capacity (PCU/hr)	RFC	Throughput (PCU/hr)	End queue (PCU)	Delay (s)	Unsignalised level of service
A	453	337	868	0.522	456	1.2	9.662	A
B	687	295	789	0.870	774	34.0	211.055	F
C	931	13	896	1.040	895	153.8	607.003	F

18:00 - 18:15

Arm	Total Demand (PCU/hr)	Circulating flow (PCU/hr)	Capacity (PCU/hr)	RFC	Throughput (PCU/hr)	End queue (PCU)	Delay (s)	Unsignalised level of service
A	379	335	870	0.436	381	0.9	8.128	A
B	575	246	819	0.702	700	2.9	57.686	F
C	780	12	897	0.870	890	126.3	567.040	F

BTM 2026 + Proposed Development, AM

Data Errors and Warnings

No errors or warnings

Junction Network

Junctions

Junction	Name	Junction type	Use circulating lanes	Arm order	Junction Delay (s)	Junction LOS
1	untitled	Mini-roundabout		A, B, C	309.47	F

Junction Network

Driving side	Lighting	Road surface	In London	Network delay (s)	Network LOS
Left	Normal/unknown	Normal/unknown		309.47	F

Traffic Demand

Demand Set Details

ID	Scenario name	Time Period name	Traffic profile type	Start time (HH:mm)	Finish time (HH:mm)	Time segment length (min)
D3	BTM 2026 + Proposed Development	AM	ONE HOUR	07:45	09:15	15

Vehicle mix source	PCU Factor for a HV (PCU)
HV Percentages	2.00

Demand overview (Traffic)

Arm	Linked arm	Use O-D data	Average Demand (PCU/hr)	Scaling Factor (%)
A		✓	470	100.000
B		✓	581	100.000
C		✓	1031	100.000

Origin-Destination Data

Demand (PCU/hr)

		To		
		A	B	C
From	A	0	174	296
	B	13	0	568
	C	180	851	0

Vehicle Mix

Heavy Vehicle Percentages

		To		
		A	B	C
From	A	0	10	10
	B	10	0	10
	C	10	10	0

Results

Results Summary for whole modelled period

Arm	Max RFC	Max Delay (s)	Max Queue (PCU)	Max LOS
A	0.84	37.25	5.0	E
B	0.83	29.15	4.9	D
C	1.27	591.54	149.5	F

Main Results for each time segment

07:45 - 08:00

Arm	Total Demand (PCU/hr)	Circulating flow (PCU/hr)	Capacity (PCU/hr)	RFC	Throughput (PCU/hr)	End queue (PCU)	Delay (s)	Unsignalised level of service
A	354	622	691	0.512	349	1.1	11.445	B
B	437	220	836	0.523	433	1.2	9.715	A
C	776	10	898	0.864	753	5.7	24.464	C

08:00 - 08:15

Arm	Total Demand (PCU/hr)	Circulating flow (PCU/hr)	Capacity (PCU/hr)	RFC	Throughput (PCU/hr)	End queue (PCU)	Delay (s)	Unsignalised level of service
A	423	714	633	0.667	419	2.1	18.113	C
B	522	264	809	0.646	519	1.9	13.544	B
C	927	12	897	1.033	865	21.1	70.606	F

08:15 - 08:30

Arm	Total Demand (PCU/hr)	Circulating flow (PCU/hr)	Capacity (PCU/hr)	RFC	Throughput (PCU/hr)	End queue (PCU)	Delay (s)	Unsignalised level of service
A	517	737	619	0.836	507	4.6	32.653	D
B	640	320	774	0.827	629	4.5	25.684	D
C	1135	14	895	1.268	893	81.6	218.800	F

08:30 - 08:45

Arm	Total Demand (PCU/hr)	Circulating flow (PCU/hr)	Capacity (PCU/hr)	RFC	Throughput (PCU/hr)	End queue (PCU)	Delay (s)	Unsignalised level of service
A	517	739	618	0.837	516	5.0	37.250	E
B	640	325	771	0.830	638	4.9	29.150	D
C	1135	14	895	1.268	895	141.7	457.317	F

08:45 - 09:00

Arm	Total Demand (PCU/hr)	Circulating flow (PCU/hr)	Capacity (PCU/hr)	RFC	Throughput (PCU/hr)	End queue (PCU)	Delay (s)	Unsignalised level of service
A	423	739	618	0.684	433	2.5	22.363	C
B	522	272	803	0.650	533	2.1	15.231	C
C	927	12	897	1.034	896	149.5	591.538	F

09:00 - 09:15

Arm	Total Demand (PCU/hr)	Circulating flow (PCU/hr)	Capacity (PCU/hr)	RFC	Throughput (PCU/hr)	End queue (PCU)	Delay (s)	Unsignalised level of service
A	354	736	620	0.571	358	1.5	15.325	C
B	437	225	832	0.525	441	1.2	10.205	B
C	776	10	898	0.864	891	120.7	546.457	F

BTM 2026 + Proposed Development, PM

Data Errors and Warnings

No errors or warnings

Junction Network

Junctions

Junction	Name	Junction type	Use circulating lanes	Arm order	Junction Delay (s)	Junction LOS
1	untitled	Mini-roundabout		A, B, C	527.20	F

Junction Network

Driving side	Lighting	Road surface	In London	Network delay (s)	Network LOS
Left	Normal/unknown	Normal/unknown		527.20	F

Traffic Demand

Demand Set Details

ID	Scenario name	Time Period name	Traffic profile type	Start time (HH:mm)	Finish time (HH:mm)	Time segment length (min)
D4	BTM 2026 + Proposed Development	PM	ONE HOUR	16:45	18:15	15

Vehicle mix source	PCU Factor for a HV (PCU)
HV Percentages	2.00

Demand overview (Traffic)

Arm	Linked arm	Use O-D data	Average Demand (PCU/hr)	Scaling Factor (%)
A		✓	504	100.000
B		✓	850	100.000
C		✓	1093	100.000

Origin-Destination Data

Demand (PCU/hr)

		To		
		A	B	C
From	A	0	178	326
	B	13	0	837
	C	703	390	0

Vehicle Mix

Heavy Vehicle Percentages

		To		
		A	B	C
From	A	0	10	10
	B	10	0	10
	C	10	10	0

Results

Results Summary for whole modelled period

Arm	Max RFC	Max Delay (s)	Max Queue (PCU)	Max LOS
A	0.63	12.20	1.9	B
B	1.25	472.77	105.7	F
C	1.34	807.01	208.4	F

Main Results for each time segment

16:45 - 17:00

Arm	Total Demand (PCU/hr)	Circulating flow (PCU/hr)	Capacity (PCU/hr)	RFC	Throughput (PCU/hr)	End queue (PCU)	Delay (s)	Unsignalised level of service
A	379	282	903	0.420	376	0.8	7.478	A
B	640	243	821	0.779	626	3.5	19.099	C
C	823	10	898	0.916	791	8.1	30.907	D

17:00 - 17:15

Arm	Total Demand (PCU/hr)	Circulating flow (PCU/hr)	Capacity (PCU/hr)	RFC	Throughput (PCU/hr)	End queue (PCU)	Delay (s)	Unsignalised level of service
A	453	315	882	0.514	452	1.1	9.164	A
B	764	292	791	0.966	732	11.5	50.457	F
C	983	11	897	1.095	882	33.3	99.667	F

17:15 - 17:30

Arm	Total Demand (PCU/hr)	Circulating flow (PCU/hr)	Capacity (PCU/hr)	RFC	Throughput (PCU/hr)	End queue (PCU)	Delay (s)	Unsignalised level of service
A	555	320	879	0.631	552	1.8	12.008	B
B	936	357	751	1.247	746	58.9	184.471	F
C	1203	11	897	1.342	896	110.2	298.553	F

17:30 - 17:45

Arm	Total Demand (PCU/hr)	Circulating flow (PCU/hr)	Capacity (PCU/hr)	RFC	Throughput (PCU/hr)	End queue (PCU)	Delay (s)	Unsignalised level of service
A	555	320	879	0.631	555	1.9	12.203	B
B	936	359	749	1.249	749	105.7	399.949	F
C	1203	11	897	1.342	897	186.8	603.780	F

17:45 - 18:00

Arm	Total Demand (PCU/hr)	Circulating flow (PCU/hr)	Capacity (PCU/hr)	RFC	Throughput (PCU/hr)	End queue (PCU)	Delay (s)	Unsignalised level of service
A	453	320	879	0.515	456	1.2	9.413	A
B	764	295	789	0.968	781	101.4	472.771	F
C	983	12	897	1.096	896	208.4	800.353	F

18:00 - 18:15

Arm	Total Demand (PCU/hr)	Circulating flow (PCU/hr)	Capacity (PCU/hr)	RFC	Throughput (PCU/hr)	End queue (PCU)	Delay (s)	Unsignalised level of service
A	379	318	880	0.431	381	0.8	7.953	A
B	640	246	819	0.781	811	58.7	357.827	F
C	823	12	896	0.918	892	191.2	807.011	F

ATTACHMENT B

VTP DRAWINGS



Key:

- Existing Elmsbrook Housing (52 Dwellings)
- Existing Elmsbrook Parking (99 Spaces)
- Existing Elmsbrook Garages (14 Units)

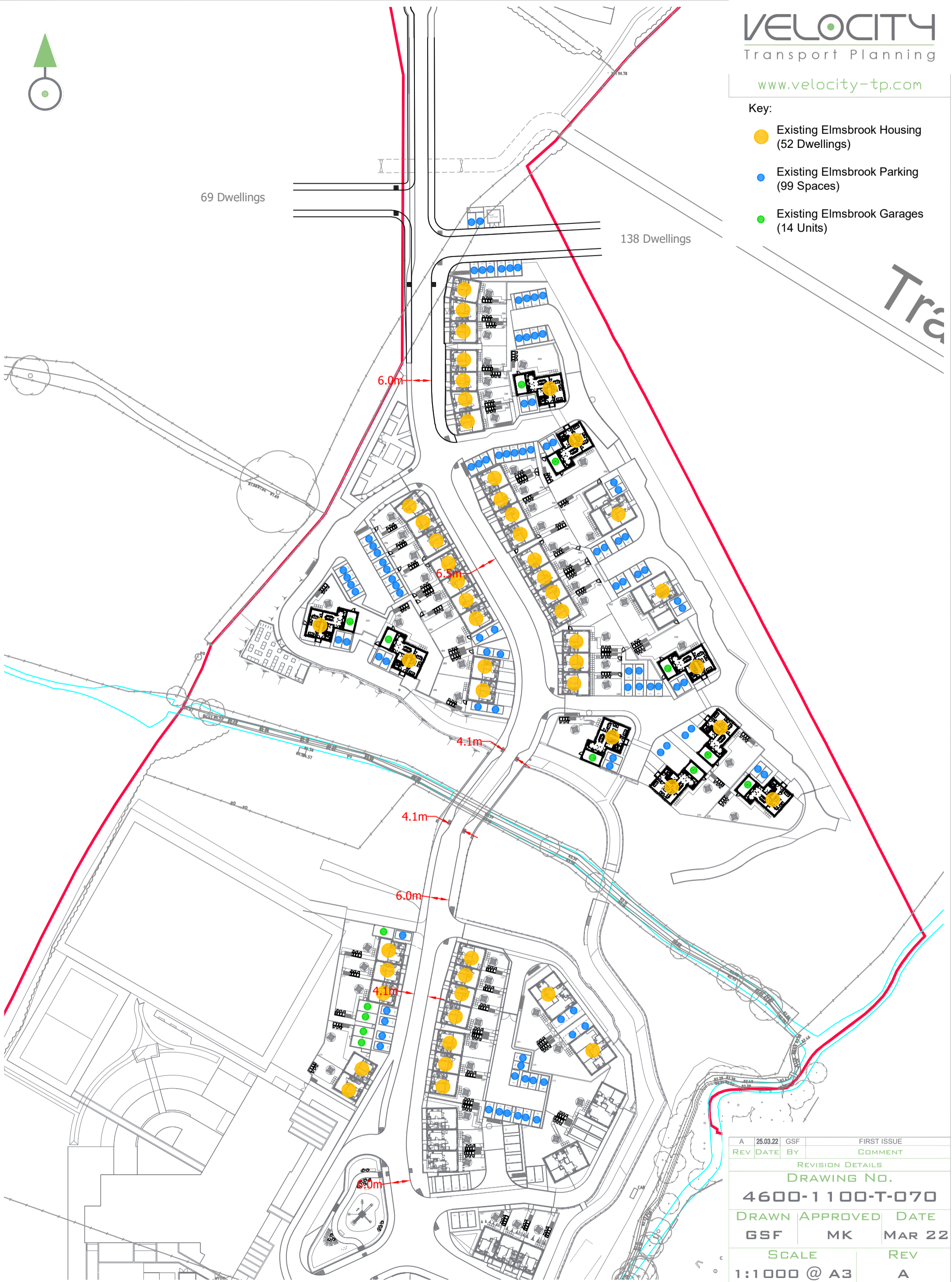

A	25.03.22	GSF	FIRST ISSUE
REV	DATE	BY	COMMENT
REVISION DETAILS			
DRAWING No.			
4600-1100-T-070			
DRAWN		APPROVED	DATE
GSF		MK	MAR 22
SCALE			REV
1:1000 @ A3			A

CLIENT
FIRETHORN TRUST

PROJECT
NW BICESTER

DRAWING TITLE
**ELMSBROOK SPINE
ROAD ASSESSMENT**



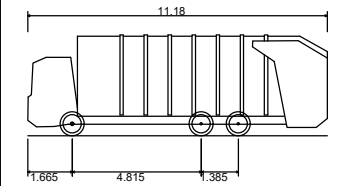

Phoenix 2 One-Pass (with Elite 6x4 chassis)
Overall Length 11.180m
Overall Width 2.550m
Overall Body Height 3.760m
Min Body Ground Clearance 0.312m
Track Width 2.550m
Lock to lock time 4.00s
Kerb to Kerb Turning Radius 10.150m

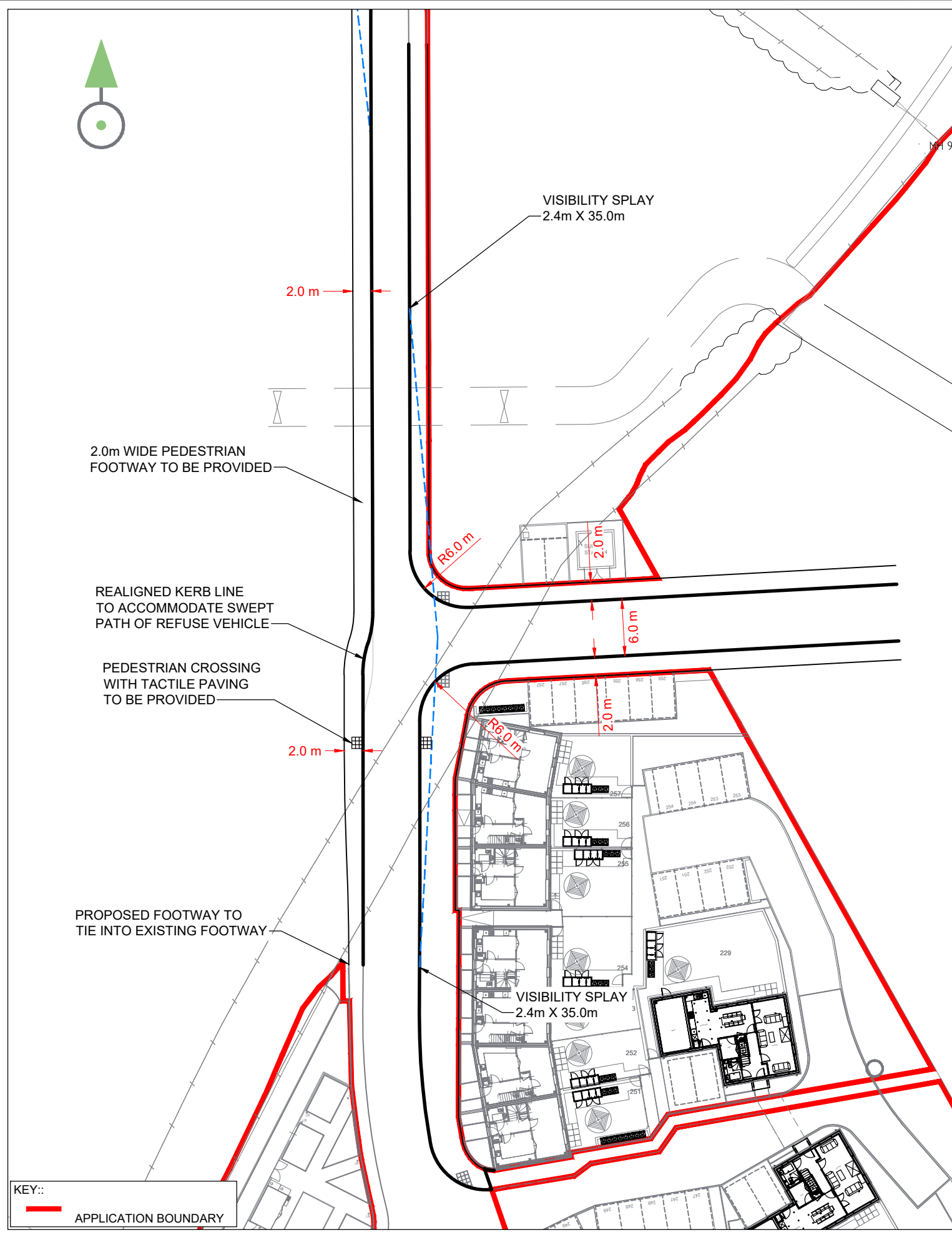
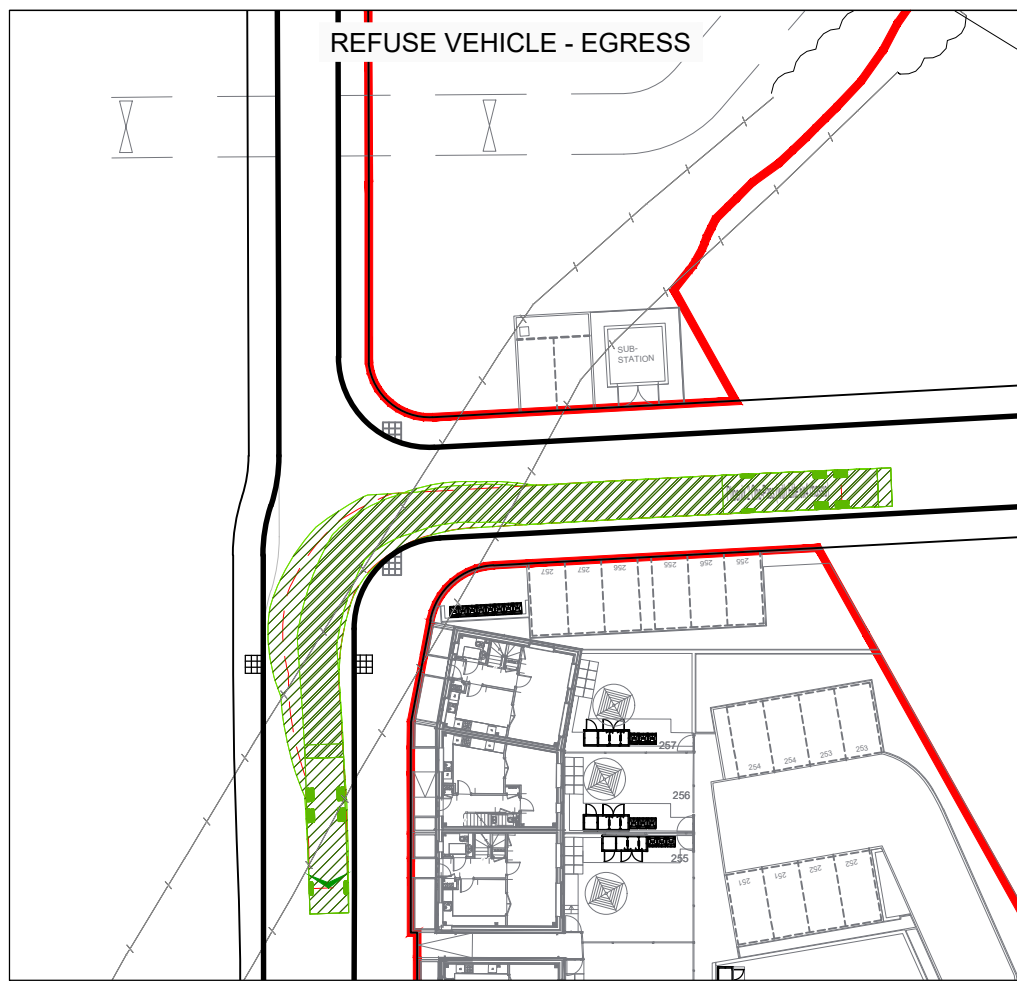
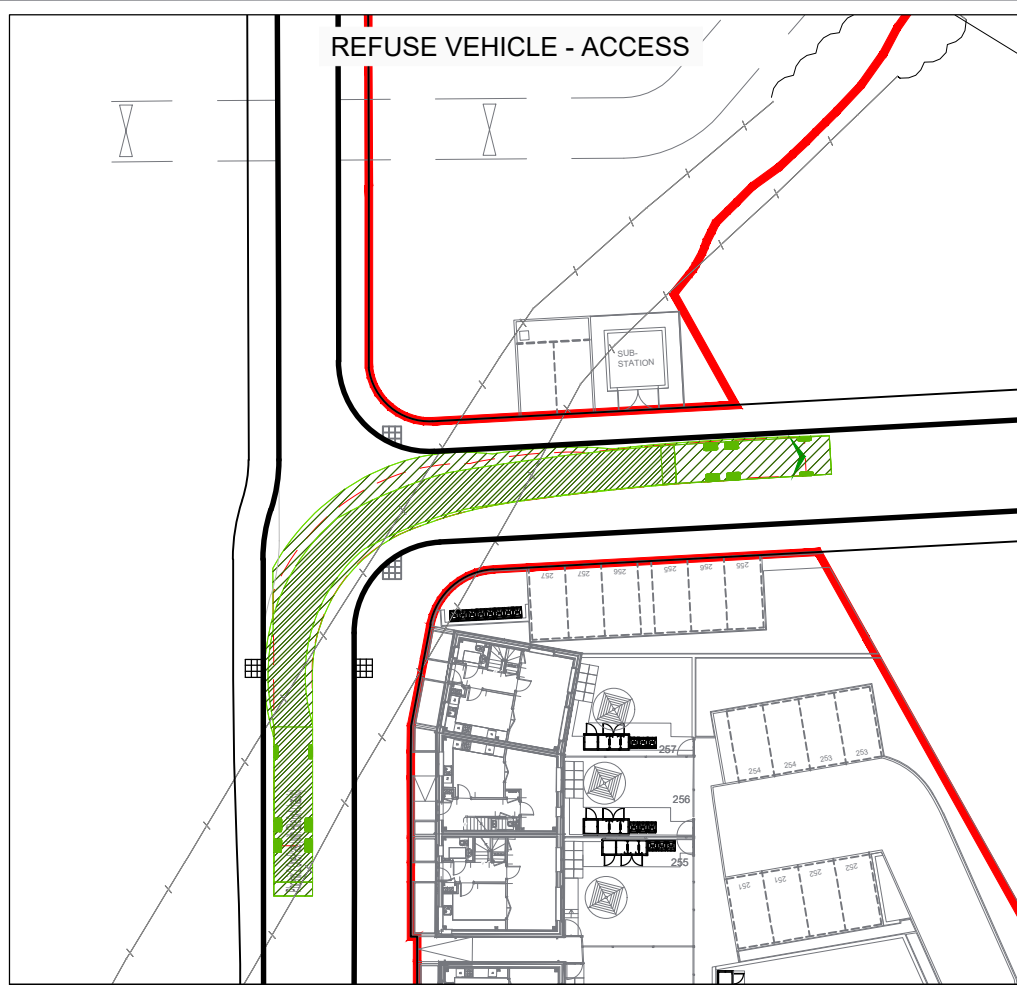

KEY::
APPLICATION BOUNDARY

A	20.01.22	FIRST ISSUE	MK
REV	DATE	COMMENT	APP
REVISION DETAILS			
DRAWING No.			
4600-1100-T-040			
DRAWN		APPROVED	DATE
EP		MK	JAN 22
SCALE		REV	
1:500 @ A3		A	





2.0m WIDE PEDESTRIAN FOOTWAY TO BE PROVIDED

VISIBILITY SPLAY
2.4m X 35.0m

VISIBILITY SPLAY
2.4m X 35.0m

2.0 m

2.0 m

6.0 m

2.0 m

R6.0 m

REALIGNED KERB LINE

PEDESTRIAN CROSSING WITH TACTILE PAVING TO BE PROVIDED

2.0 m

VISIBILITY SPLAY
2.4m X 35.0m

PROPOSED FOOTWAY TO TIE INTO EXISTING FOOTWAY

VISIBILITY SPLAY
2.4m X 35.0m

KEY::
APPLICATION BOUNDARY

REFUSE VEHICLE - ACCESS

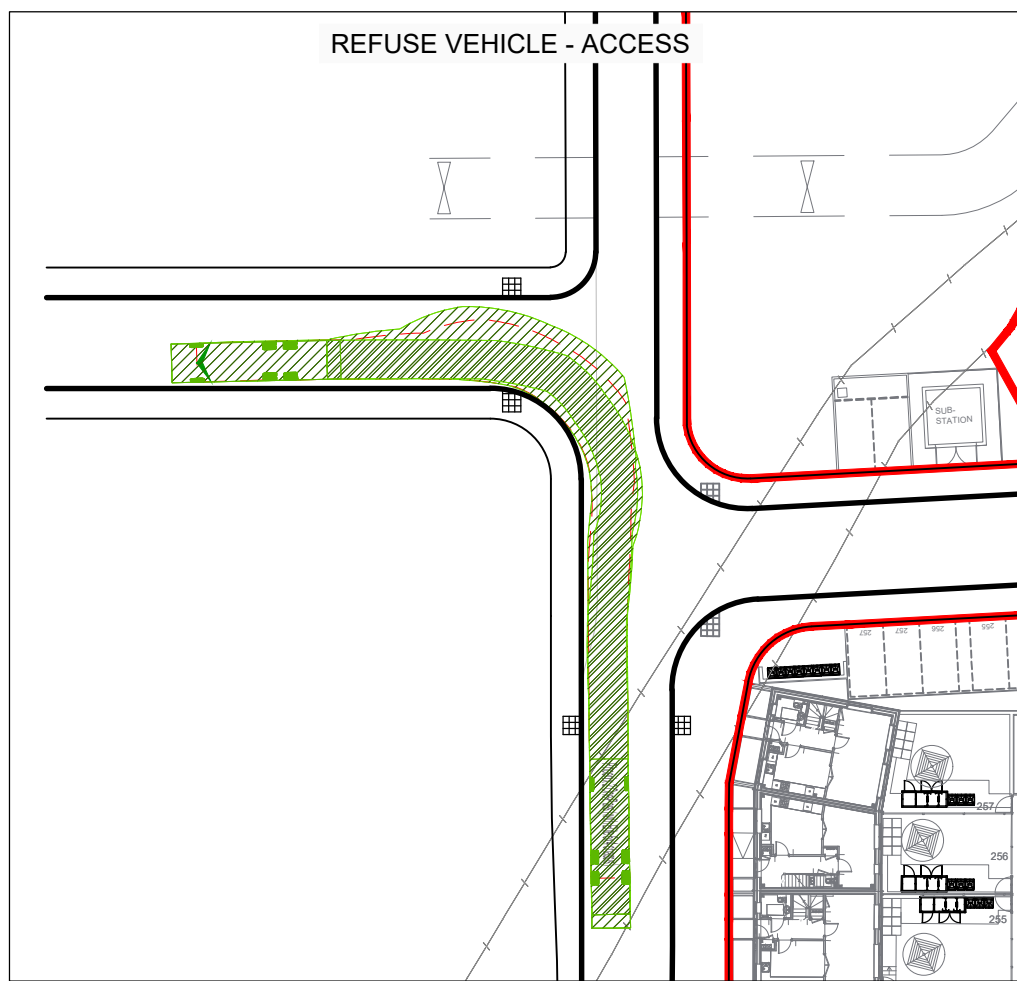

REFUSE VEHICLE - EGRESS

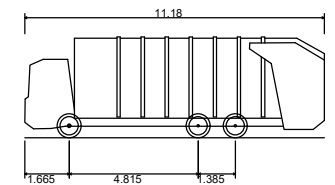
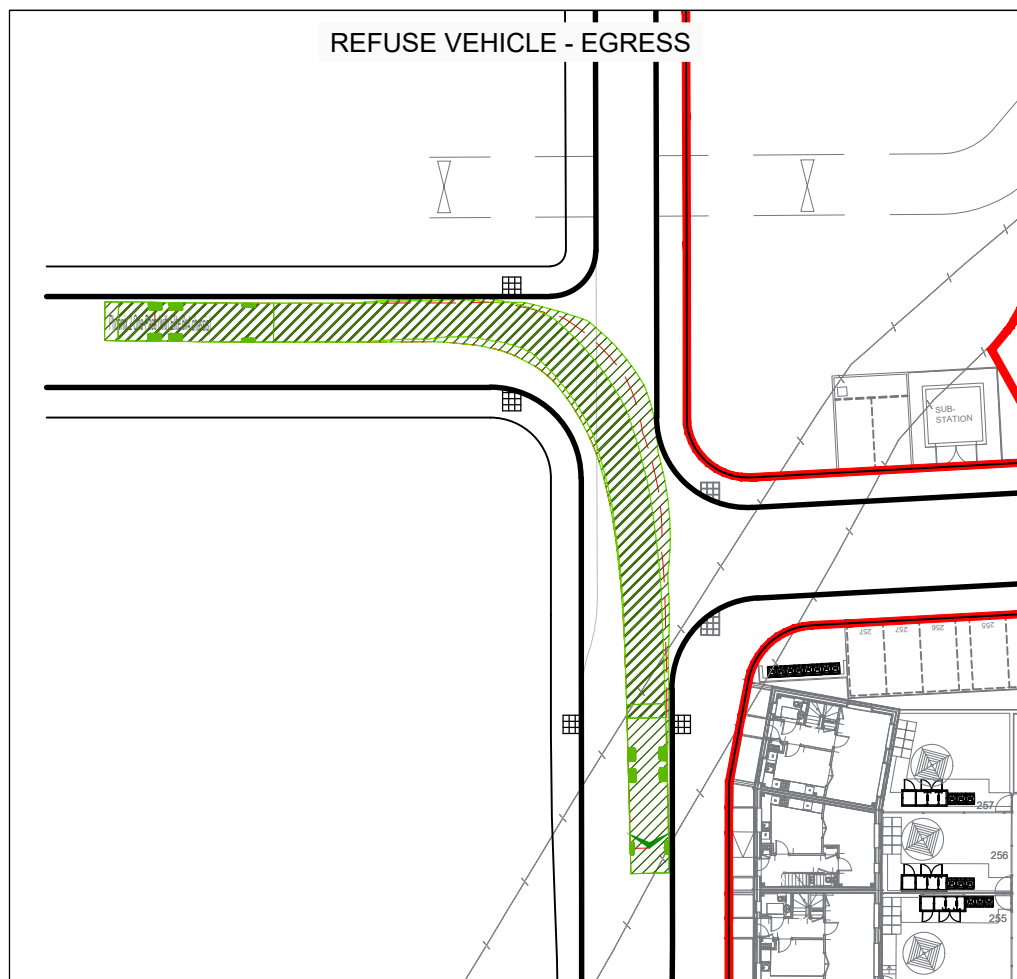

Phoenix 2 One-Pass (with Elite 6x4 chassis)

Overall Length	11.180m
Overall Width	2.550m
Overall Body Height	3.760m
Min Body Ground Clearance	0.312m
Track Width	2.550m
Lock to lock time	4.00s
Kerb to Kerb Turning Radius	10.150m

A	20.01.22	FIRST ISSUE	MK
REV	DATE	COMMENT	APP

REVISION DETAILS		
DRAWING No.		
4600-1100-T-041		
DRAWN	APPROVED	DATE
EP	MK	JAN 22
SCALE		REV
1:500 @ A3		A



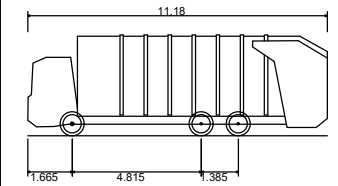

Phoenix 2 One-Pass (with Elite 6x4 chassis)
 Overall Length 11.180m
 Overall Width 2.550m
 Overall Body Height 3.760m
 Min Body Ground Clearance 0.312m
 Track Width 2.550m
 Lock to lock time 4.00s
 Kerb to Kerb Turning Radius 10.150m

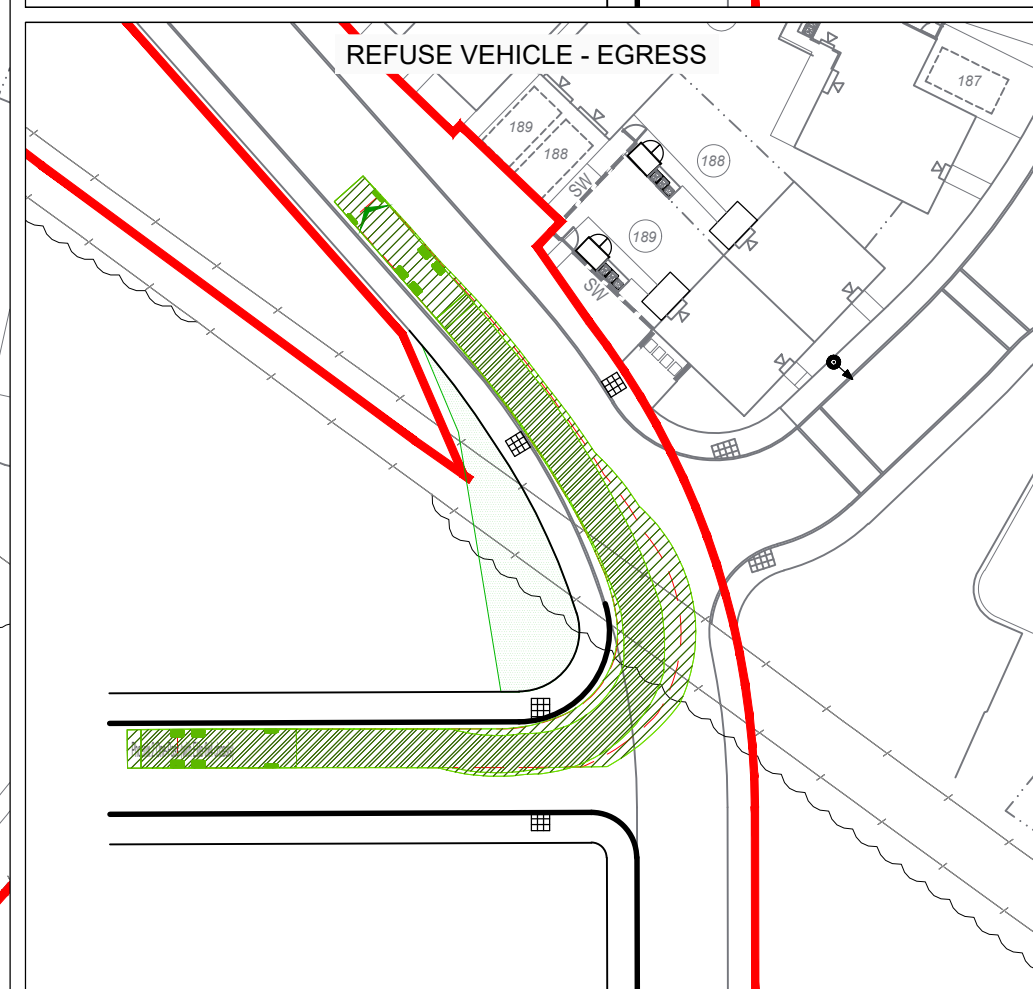
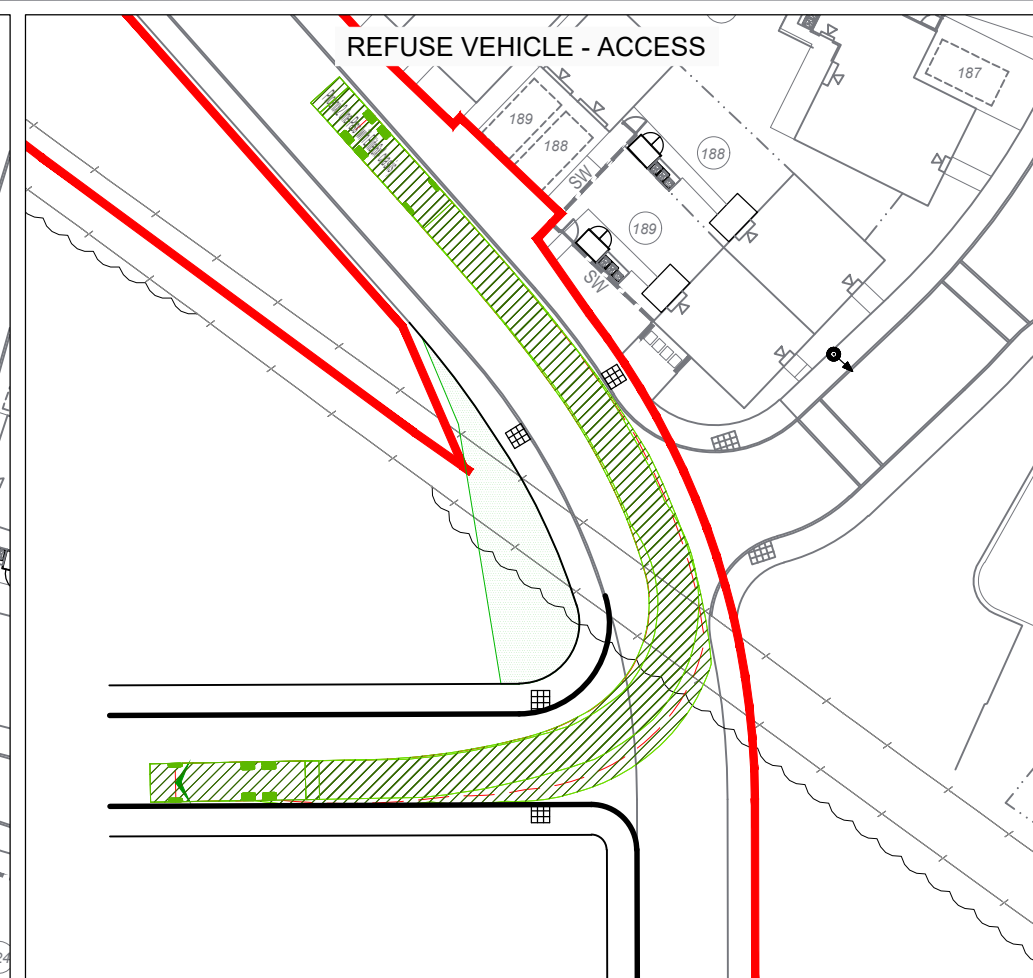
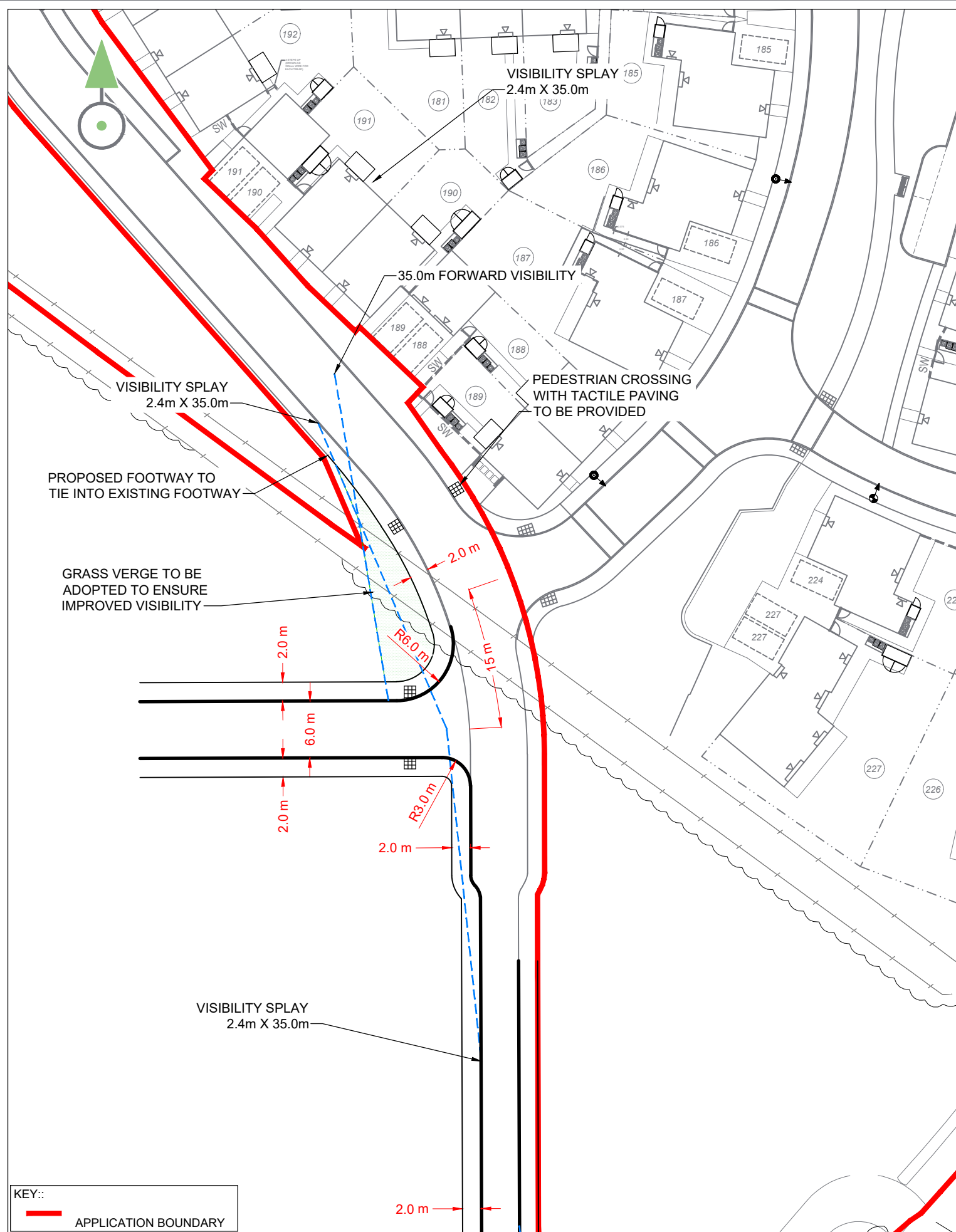

REV	DATE	COMMENT	APP
A	20.01.22	FIRST ISSUE	MK

REVISION DETAILS

DRAWING NO.
4600-1100-T-042

DRAWN	APPROVED	DATE
EP	MK	JAN 22

SCALE	REV
1:500 @ A3	A



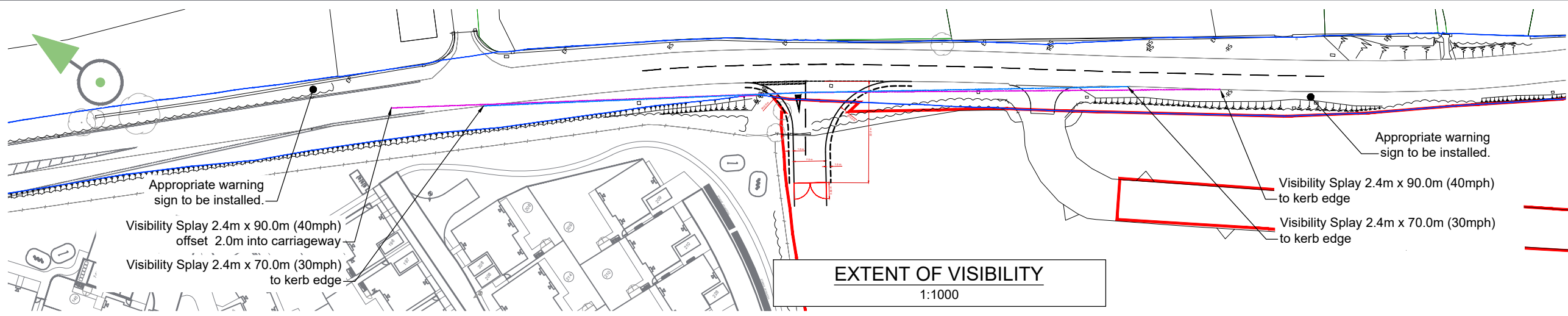

EXTENT OF VISIBILITY
1:1000

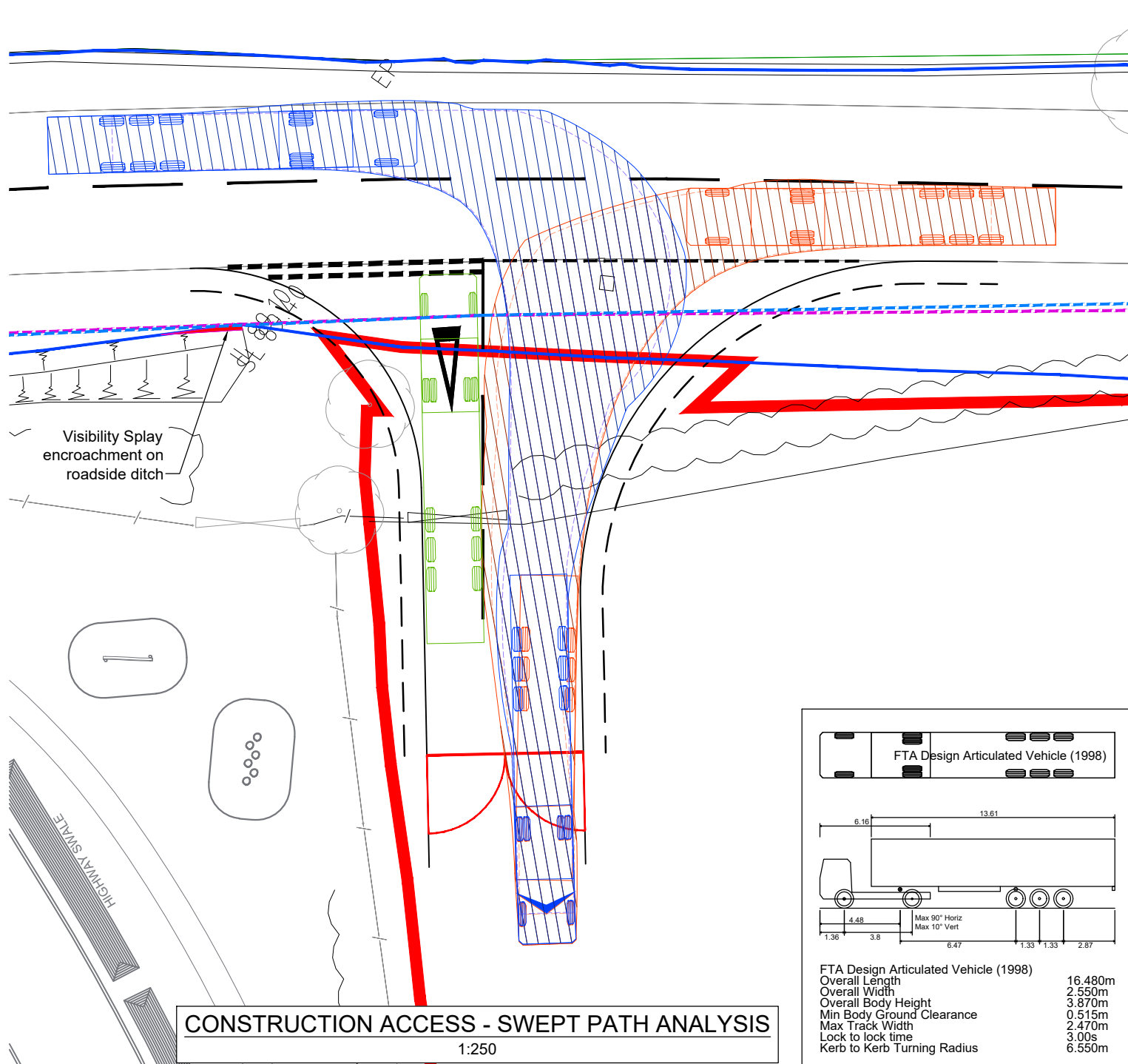

FTA Design Articulated Vehicle (1998)	
Overall Length	16.480m
Overall Width	2.550m
Overall Body Height	3.870m
Min Body Ground Clearance	0.515m
Max Track Width	2.470m
Lock to lock time	3.00s
Kerb to Kerb Turning Radius	6.550m

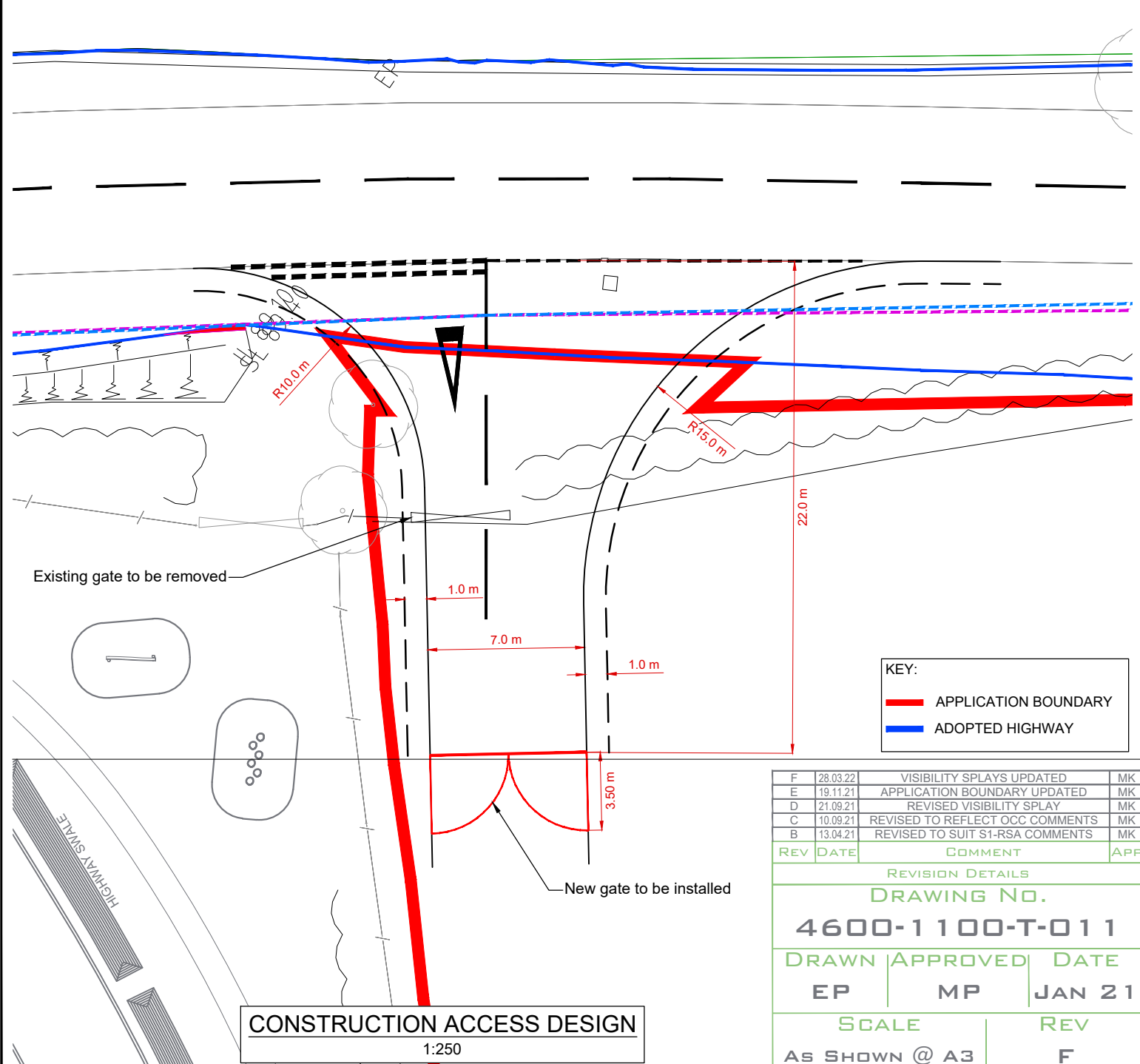

KEY:

- APPLICATION BOUNDARY
- ADOPTED HIGHWAY

REV	DATE	COMMENT	APP
F	28.03.22	VISIBILITY SPLAYS UPDATED	MK
E	19.11.21	APPLICATION BOUNDARY UPDATED	MK
D	21.09.21	REVISED VISIBILITY SPLAY	MK
C	10.09.21	REVISED TO REFLECT OCC COMMENTS	MK
B	13.04.21	REVISED TO SUIT S1-RSA COMMENTS	MK

REVISION DETAILS

DRAWING NO.
4600-1100-T-011

DRAWN	APPROVED	DATE
EP	MP	JAN 21

SCALE: AS SHOWN @ A3

REV: F



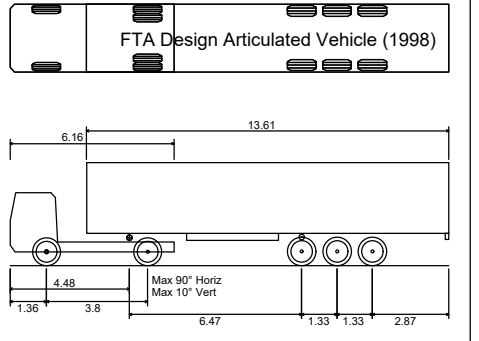

FTA Design Articulated Vehicle (1998)	
Overall Length	16.480m
Overall Width	2.550m
Overall Body Height	3.870m
Min Body Ground Clearance	0.515m
Max Track Width	2.470m
Lock to lock time	3.00s
Kerb to Kerb Turning Radius	6.550m

- Key:
- Highway Boundary
 - Elmsbrook Site Boundary
 - Application Boundary

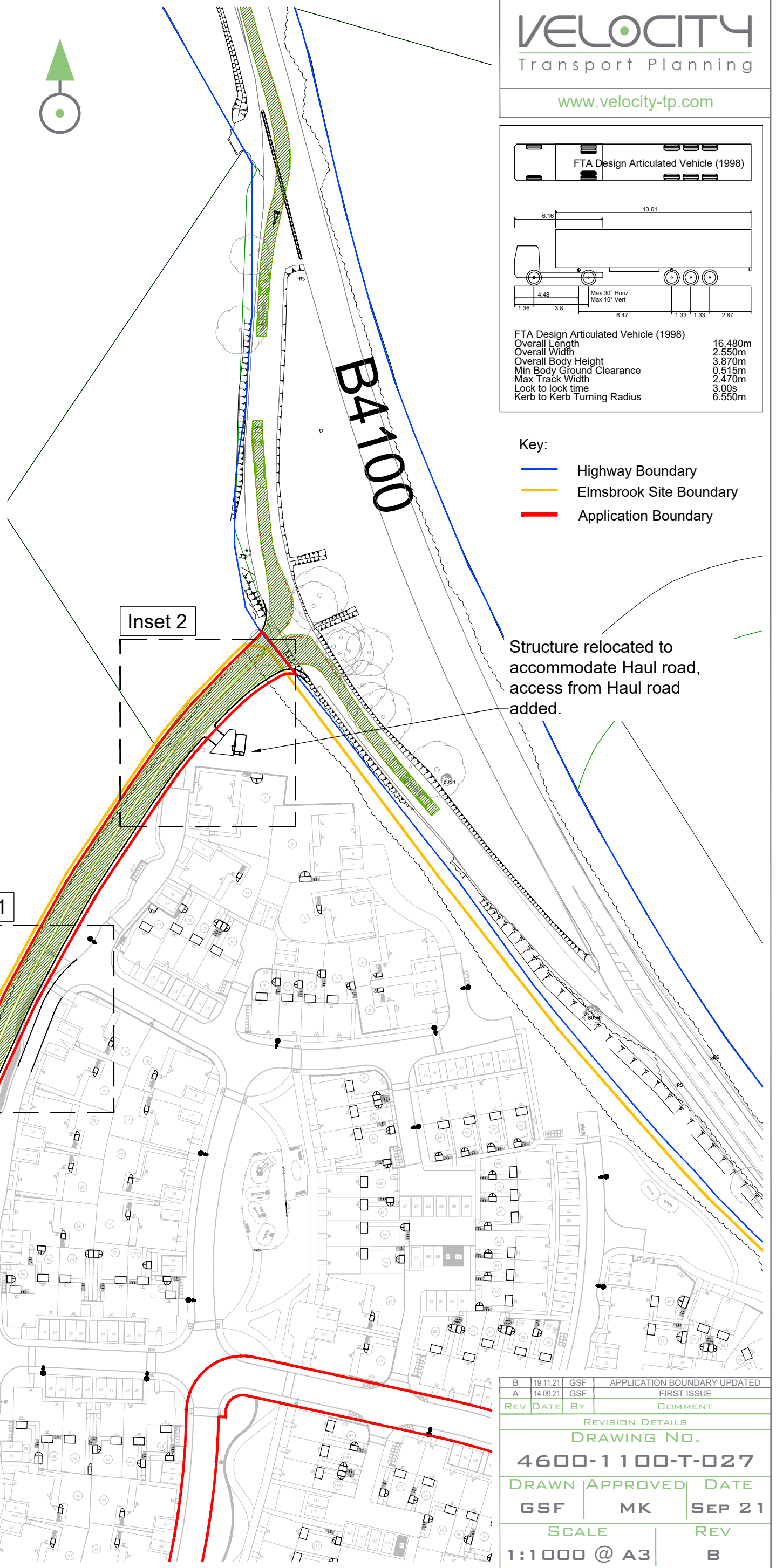
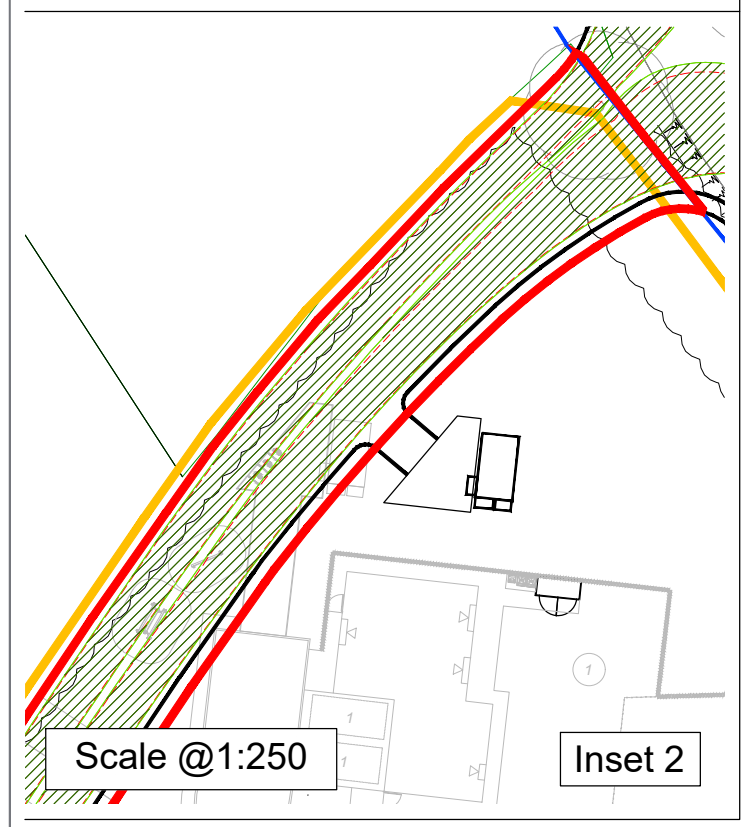
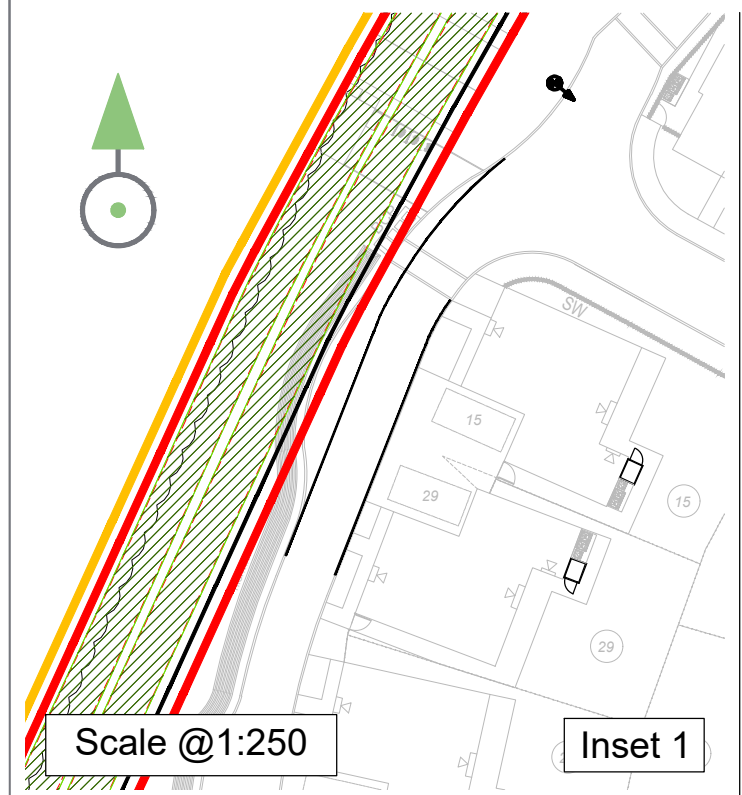

Structure relocated to accommodate Haul road, access from Haul road added.

Adjustment to Phase 4 road design to accommodate Proposed Haul road

B	19.11.21	GSF	APPLICATION BOUNDARY UPDATED
A	14.09.21	GSF	FIRST ISSUE
REV	DATE	BY	COMMENT
REVISION DETAILS			
DRAWING NO.			
4600-1100-T-027			
DRAWN		APPROVED	DATE
GSF		MK	SEP 21
SCALE		REV	
1:1000 @ A3		B	

