



# ARBORICULTURAL METHOD STATEMENT

The Leys, Adderbury  
Mr Nick Biggam

framptons

AA AMS 05  
May 2020



**Apical Arbor reserves all rights to this document.** This document, in whole or in part, may not be reproduced, stored in a retrieval system, transmitted in any form or by any means, electronic, mechanical, recorded, photocopied or otherwise, without the prior permission of Philip Bridger.

**Apical Arbor**  
**Astwell Castle Farm**  
**Helmdon**  
**Nr Brackley**  
**Northamptonshire**  
**NN13 5QU**



## CONTENTS

Chapter		Page
1	Summary	1
2	Introduction	2
3	Tree Preservation Orders	3
5	Survey and Explanation of BS 5837:2012 Categories	4
6	Tree Removals	9
7	Tree Protection / Special construction methods	12
8	Conclusions	13
Appendices		15
<b>Appendix A</b>	Tree Schedule - AA TS 01	
<b>Appendix B</b>	Tree Location Plan – AA TL 01	
<b>Appendix C</b>	Tree Protection Plan – AA TPP 05	
<b>Appendix D</b>	Dwg No. PF9614.01 Location Plan – April 2020 revision	

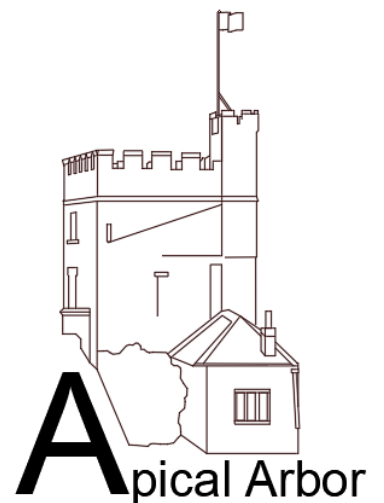

## 1 Summary

- 1.1 Following instructions received in May 2018, this statement has been produced to inform a planning application for the development of two residential units within the boundary of The Leys, Adderbury. The Site and proposed development have been assessed in accordance with the relevant British Standard, BS 5837:2012 'Trees in Relation to Design, Demolition and Construction'.
- 1.2 The Arboricultural survey was carried out by Philip Bridger. The schedule provided in Appendix A provides a detailed record of each of these components. Appendix B provides a graphical representation of the survey data.
- 1.3 The development will necessitate the removal of one category 'C' collection (G7) to facilitate the foot print of unit two. There are five category 'U' trees on the Site too, which should be removed regardless of any development. Just 14 trees will be removed, none of which should not considered a constraint,
- 1.4 All of the Category 'B' and 'A' trees are being retained.
- 1.5 TPO numbers have been added to the Tree protection Plan, all of these trees are being retained and protected.

## 2 Introduction

- 2.1 Following instructions received in May 2018, this statement has been produced to inform a planning application for the development of two residential units within the boundary of the Leys, Adderbury. The Site has been addressed in accordance with the relevant British Standard, BS 5837:2012 'Trees in Relation to Design, Demolition and Construction'.
- 2.2 This standard is intended to assist decision-making with regard to existing and proposed trees in the context of design, demolition and construction. It acknowledges the importance of trees and the benefits that they provide to both people and wildlife. These may include factors such as visual amenity, biodiversity and climate change adaptation / mitigation.
- 2.3 The Site is an established, and extensive, residential garden. The garden has been planted with formal borders and established specimen trees. A tennis court is present on the south side of the site, and an existing concrete access to the sewage works is present on the north side. There is an extensive and informed species list present in this garden, and the notable examples are all being retained. One of the highlights in this garden is the Handkerchief tree T32 which was surveyed whilst in full 'handkerchief' bloom. See below.



- 2.4 This report provides an informed overview of the existing tree cover, a summary of any implications arising from the proposed scheme and comments regarding the integration of existing trees into the proposed setting.
- 2.5 The following information does not constitute a health and safety survey or report. Where concerns for tree health and safety exist the necessary and appropriate tree inspections should be undertaken.
- 2.6 This report considers only the arboricultural component of the Site. It does not include the fauna or the entire flora present on the Site, and should not be used as an ecological appraisal.

### 3 Tree Preservation Orders

All trees subject to a Tree Preservation Order are being retained and protected.

TPO 01 – Red Oak, T19

TPO 02 – Copper Beech, T20

TPO 03 – English Oak, T24

TPO 04 – Japanese Cedar, T35

TPO 05 – Golden Laylandii, T37

TPO 06 – Swedish Whitebeam, T38

TPO 07 – Norway Maple, T39

TPO 08 – Swedish Whitebeam, T47

TPO 09 – Norway Spruce, T64

## 5 Survey and Explanation of BS 5837:2012 Categories

- 5.1.1 This type of survey is designed to identify and assess trees likely to be affected by development of the Site and assign them to appropriate categories. The results of the tree survey, including material constraints arising from existing trees that merit retention, should then be used to inform the design process.
- 5.2 The schedule provided in Appendix A provides a detailed record of each of these components. Appendix B provides a graphical representation of the survey data.
- 5.2.1 There are a wide range of species and quality of tree across the Site, including very good examples of mature trees.
- 5.3 Trees are surveyed on an individual basis unless they form a collective feature when they may be considered as a woodland, group or hedge on the basis of aerodynamic, cultural or visual features. Individual trees of particular prominence or value within a collection may still be assessed as individuals.

5.3.1 For each surveyed tree/group the following information has been recorded:

- i. TREE NO.: Used to identify trees in the schedule and associated plans.
- ii. SPECIES: Common names are used in this document and the Tree Schedule. Scientific names are provided in Appendix D.
- iii. HEIGHT: Height of tree in metres to the centre of the crown top or highest point.
- iv. DBH: Diameter of the tree at 1.5m from ground level or at the closest appropriate point if this is not possible. Where multiple stems are present these are measured individually where practicable. This measurement is used to calculate the Root Protection Area (RPA) for each tree.
- v. CROWN SPREAD: Measured at appropriate compass points e.g. N, E, S, W. Dimensions are taken from the centre of the main trunk. An 'Up to' figure may be provided in some circumstances e.g. for smaller specimens or where access is restricted.
- vi. CROWN CLEARANCE: Height to the lowest branch from ground level. Small twigs and epicormic growth may be present below this level but could be removed with no detriment to the tree.
- vii. PHYSIOLOGY and STRUCTURE: Description of general form, including presence of physical defects, disease or decay and other appropriate details based on health, vitality and overall structural integrity.
- viii. AGE CLASS: Young / Middle-aged / Mature / Over Mature / Veteran. Veteran trees are those deemed to be of significant biological, cultural or aesthetic value, usually beyond typical age range and often exhibiting significant structural defects.

5.3.2 Trees are categorised as per Table 1 of BS 5837:2012; these are divided between retention categories 'A' – 'U'.



#### 5.4 Explanation of Categories:

- i. **Category U:** Those in such a condition that any existing value would be lost within 10 years or which should, in the current context, be removed for reasons of sound arboricultural management. If within ownership, category U trees should not be considered as constraints within the planning process. However, it may be desirable to seek retention of a category U specimen if it is considered to have significant ecological or conservation value. Category U trees are identified by dark red canopy edges on the tree plans. A dark grey RPA may be included if the trees are offsite or desirable for retention.
- ii. **Category A:** Those of high quality and value: in such a condition as to be able to make a substantial contribution (a minimum of 40 years is suggested). These are identified by light green RPAs on the tree plans.
- iii. **Category B:** Those of moderate quality and value: those in such a condition as to make a significant contribution (a minimum of 20 years is suggested). These are identified by dark blue RPAs on the tree plans.
- iv. **Category C:** Those of low quality and/or value: currently in adequate condition to remain until new planting could be established (a minimum of 10 years is suggested), or young trees with a stem diameter below 150mm. These are identified by dark grey RPAs on the tree plans.

5.4.1 The following subcategories may be applied if appropriate. Trees may be allocated more than one subcategory, but this will not increase their overall value.

- i. Mainly **arboricultural** values (suffix 1)

**A1:** Trees that are particularly good examples of their species, especially if rare or unusual; or those that are essential components of groups or formal or semi-formal arboricultural features (e.g. the dominant and/or principal trees within an avenue).

**B1:** Trees that might be included in category A, but are downgraded because of impaired condition (e.g. presence of significant though remediable defects, including unsympathetic past management and major storm damage), such that they are unlikely to be suitable for retention in the long term; or trees lacking the special quality necessary to merit the category A designation.

**C1:** Unremarkable trees of very limited merit or such condition that they do not qualify in higher categories.

ii. Mainly **landscape** values (suffix 2)

**A2:** Trees, groups or woodlands of particular visual importance as arboricultural and/or landscape features.

**B2:** Trees present in numbers, usually growing as groups or woodlands, such that they attract a higher collective rating than they might as individuals; or trees occurring as collectives but situated so as to make little visual contribution to the wider locality.

**C2:** Trees present in groups or woodlands, but without this conferring on them significantly greater collective landscape value; and/or trees offering low or only temporary/transient landscape benefit.

iii. Mainly **cultural** values, including **conservation** (suffix 3)

**A3:** Trees, groups or woodlands of significant conservation, historical, commemorative or other value (e.g. veteran trees or wood-pasture).

**B3:** Trees with material conservation or other cultural value.

**C3:** Trees with no material conservation or other cultural value.

5.4.2 **Note:** as a general rule and irrespective of subcategories: category A trees are considered to be of the highest priority for retention; category B of moderate priority and those of

category C standing of lower priority. Onsite category U trees are given the lowest priority for retention.

5.5 The Root Protection Area (RPA) is the minimum soil surface area (in m<sup>2</sup>) that should be left undisturbed around each tree to maintain the tree's long-term viability. In First Environment drawings RPAs are illustrated in colour to indicate the extent of the constraint posed and show the category of the relevant tree or group:

- Category A trees/groups: **Green** RPA
- Category B trees/groups: **Blue** RPA
- Category C trees/groups: **Grey** RPA
- Offsite/Retained category U trees/groups: **Grey** RPA\*
- Onsite category U or Removed trees/groups: **No** RPA\*

\*Category U trees are identified by a **Dark Red** canopy edge

## 6 Tree Removals

6.1 New developments can be greatly enhanced by the presence of appropriate trees. The retention of suitable specimens can significantly aid the integration of new structures into an existing landscape and allow a degree of continuity for both people and wildlife alike. However, care must be taken to safeguard retained stock and minimise impacts, especially disturbance to the rooting environment.

6.1.1 Construction often entails extensive groundwork such as excavation, cutting, filling and compaction. These changes can not only directly damage roots but also affect the physical and chemical properties of the soil and so impair root growth or function.

6.1.2 The development will necessitate the removal of a collection of conifers, located in the residential garden of the building that will be moved for the access road. All other trees within this residential garden should be retained and protected.

6.1.3 The assessment is informed by tree location, current size, future requirements, root morphology and the proposed rooting environment. The tolerance of the trees to disturbance based on species, age, condition and the presence of surrounding trees and / or built form is also considered.

6.2 **Tree Works:** The development will necessitate the removal of groups, G7 & G8 as well as individual trees detailed below;

Tree Removals Summary			
Category A	Category B	Category C	Category U
0	0	14	5
Category C group of trees G2 & G3 will be partially removed.			
Category C groups of trees G7 will be removed entirely.			

Tree Removal Schedule			
Tree No.	Category	Species	Note
T01	C <sub>12</sub>	Laburnum	To be removed for grass kerb
T25	C <sub>12</sub>	Silver Birch	
T26	C <sub>12</sub>	Manchurian Cherry	
[27]	U	Wild Cherry	To be removed regardless of development
T28	C <sub>12</sub>	Rowan	
T29	C <sub>12</sub>	Purple Plum	
T30	C <sub>12</sub>	Juniper	
[31]	U	Indian Bean Tree	To be removed regardless of development
T33	C <sub>12</sub>	Wingnut	
T34	C <sub>12</sub>	Manchurian Cherry	
T40	C <sub>12</sub>	Wild Cherry	
[44]	U	Whitebeam	To be removed regardless of development
[45]	U	Black Walnut	To be removed regardless of development
T46	C <sub>12</sub>	Apple Sp.	
T54	C <sub>12</sub>	Norway Spruce	
T55	C <sub>12</sub>	Liquid Amber	
T57	C <sub>12</sub>	Scots Pine	
T58	C <sub>12</sub>	Norway Spruce	
T59	C <sub>12</sub>	Dawn Redwood	
T60	C <sub>12</sub>	Norway Spruce	

### 6.3 Pruning/crown lifting

To facilitate the development there is likely to be some remedial works to the trees along the existing access road, the majority of this work would be crown lifting, hedge trimming and dead wooding.

The following trees should be crown lifted to 4.5 on the proposed road side of their canopies;

Tree Pruning to facilitate development			
Tree No.	Category	Species	Note
G1	C <sub>12</sub>	Lawson Cypress	Trim back and gain clearance for plant.
G2	C <sub>12</sub>	Lawson Cypress	Trim back and gain clearance for plant.
T42	C <sub>12</sub>	Tulip Tree	Crown lift to 4m
Tree Pruning/ management of retained trees			
T32	B <sub>12</sub>	Handkerchief Tree	Crown lift to 2.5m
T38	B <sub>12</sub>	Swedish Whitebeam	Crown lift to 2.5m
T39	B <sub>12</sub>	Norway Maple	Crown lift to 2.5m
T47	C <sub>12</sub>	Swedish Whitebeam	Crown lift to 4m
T48	C <sub>12</sub>	Swedish Whitebeam	Crown lift to 4m
T49	B <sub>12</sub>	European Lime	Crown lift to 4m
T50	C <sub>12</sub>	Sweet Chestnut	Crown lift to 4m

## 7 Tree Protection / Special construction methods

### 7.1 Tree Protection Fencing

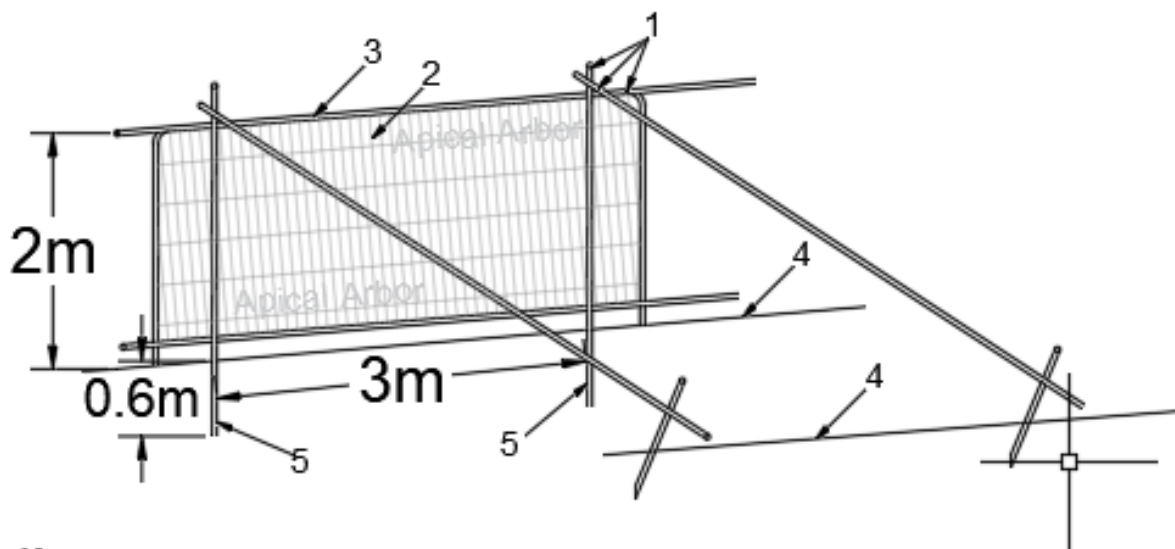

#### Key

- 1 Standard Scaffold poles
- 2 Heavy Gauge 2m tall, galvanized tube and welded mesh infill panels
- 3 Panels secured to uprights and cross members with wire ties
- 4 Ground level
- 5 Uprights driven into the ground until secure (min. 0.6m)
- 6 Standard Scaffold clamps

Tree protection fencing compliant with BS5837:2012 should be used to protect retained trees adjacent to the construction access road, and other construction activities. Specification of compliant fencing is above, on accompanying plan, Tree Protection Plan 01, Tree protection fencing is identified by the **Bold Blue Line**.

### 7.2 Above soil surfacing

The proposed footpath diversion cut across several root protection areas of retained trees including category 'A' trees. This footpath should be constructed above the existing soil surface. Adequate room has been provided between the proposed works, and the protective measures.

## 8 Conclusions

- 8.1 This statement has been produced to inform a planning application for Artificial sports pitch at Holy Cross Prep School, Kingston, a survey of trees likely to be influenced during construction has been undertaken in accordance with BS 5837:2012.
- 8.2 The development will necessitate the removal of 14 category 'C' trees, group G7, and the partial removal of G3. Removals schedule is shown above.
- 8.3 It is our opinion that trees shown as retained can be integrated within the proposed context with minimal risk of adverse impact, or that impacts can be kept within acceptable levels.

### Further Reading and Supporting Material:

British Standards Institution Publication (2010) *BS 3998: Recommendations for Tree Work*, BSI, London.

British Standards Institution Publication (2012) *BS 5837: Trees in Relation to Design, Demolition & Construction*, BSI, London.



Roberts, J., Jackson, N. & Smith, M. (2006) *Tree Roots in the Built Environment, Research for Amenity Trees No.8*, TSO, London.

# Appendices

# Appendix A Tree Schedule

AA TS 01

## Appendix B Tree Location Plan

AA TL 01

## Appendix C Tree Protection Plan

AA TPP 05

**Appendix D** Proposed Layout

5392.02 Rev E Site Layout April 2020

**Point of Contact:**

**Apical Arbor  
Astwell Castle Farm  
Helmdon  
Nr Brackley  
Northamptonshire  
NN13 5QU**



**T - 01295 768 541**

**M - 07757786101**

**E - [Apicalarbor@gmail.com](mailto:Apicalarbor@gmail.com)**

