

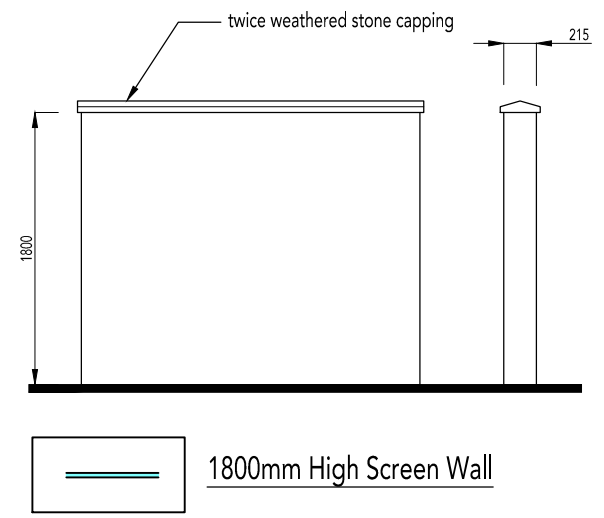

- REVISION/S:
- A. 2017-06-08. 1350mm high piers, field gate and knee rail added to the External Detailing Sheet to suit revised Planning Layout. DW
  - B. 2021-06-03. 900mm high estate railing removed and 1200mm high post & rail fence added. CM

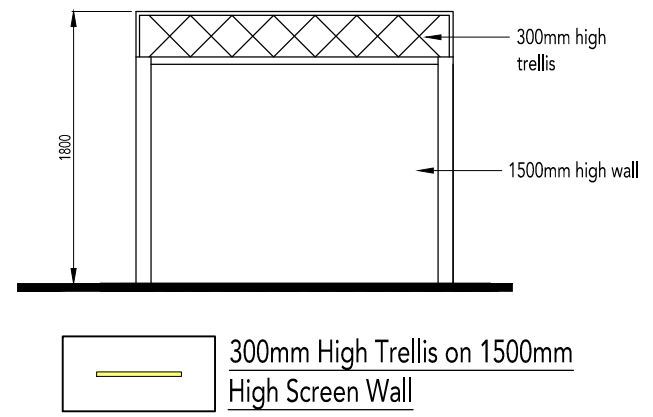

 1800mm High Screen Wall

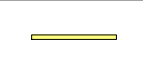

 300mm High Trellis on 1500mm High Screen Wall

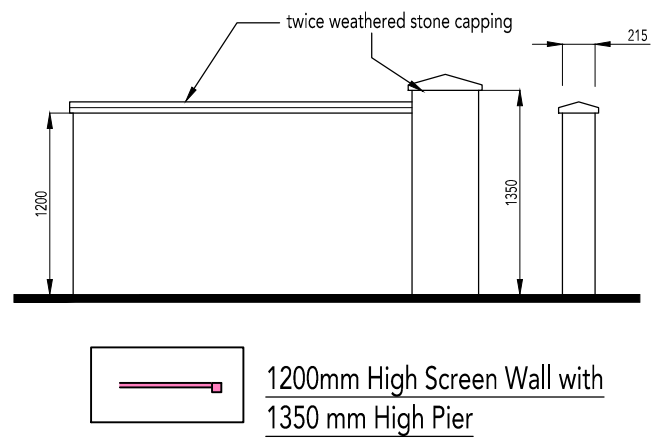

 1200mm High Screen Wall with 1350mm High Pier

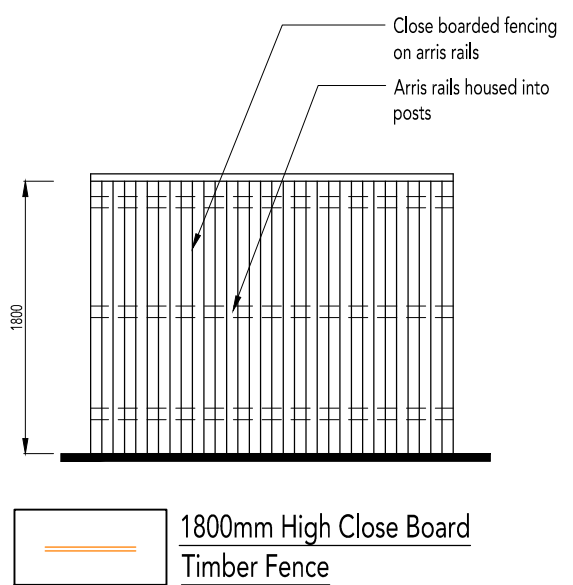

 1800mm High Close Board Timber Fence

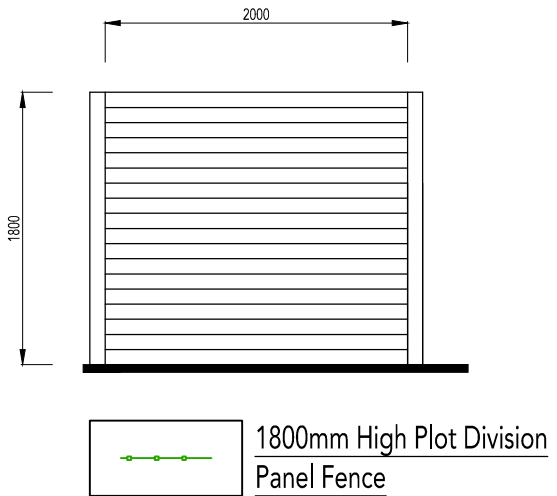

 1800mm High Plot Division Panel Fence

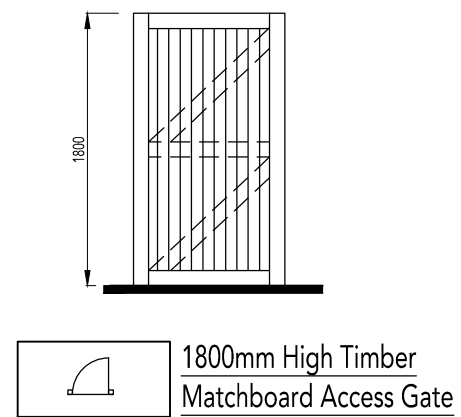

 1800mm High Timber Matchboard Access Gate

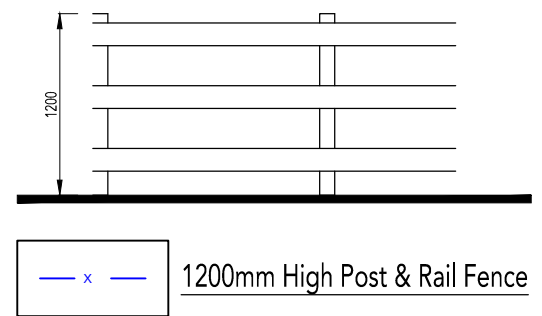

 1200mm High Post & Rail Fence

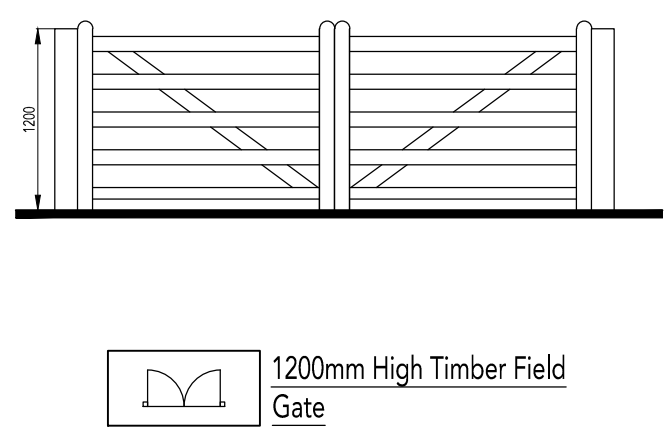

 1200mm High Timber Field Gate

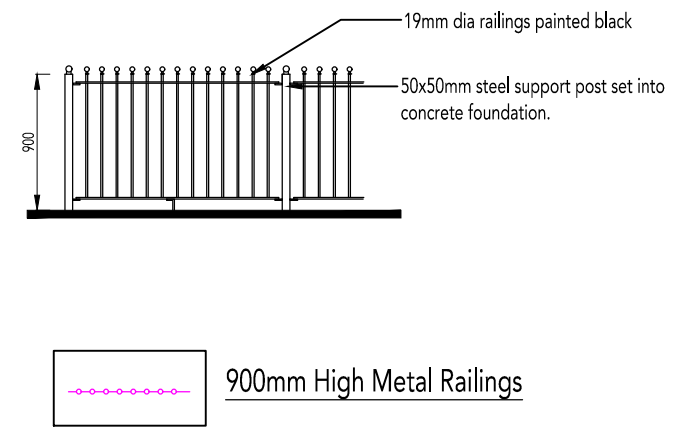

 900mm High Metal Railings

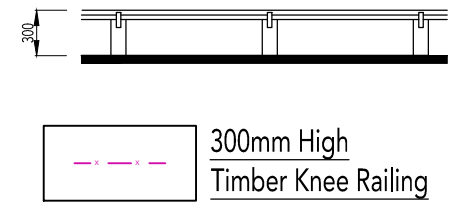

 300mm High Timber Knee Railing

**PLEASE NOTE:**

MATERIALS TO SCREEN WALLS & MASONRY PIERS TO BE INDICATED ON MATERIALS LAYOUT DRG NO: 0521-PH9-108.

