

COTEFIELD BUSINESS PARK BODICOTE

Transport Assessment

JNY9860-03
Cotefield Farm Retail
Transport Assessment
Version -
23 December 2019

Document Status

Version	Purpose of document	Authored by	Reviewed by	Approved by	Review date
-	Planning Application	Joanna Gunn	David Archibald	David Archibald	December 2019

This report was prepared by **RPS Consulting Services Ltd** ('RPS') within the terms of its engagement and in direct response to a scope of services. This report is strictly limited to the purpose and the facts and matters stated in it and does not apply directly or indirectly and must not be used for any other application, purpose, use or matter. In preparing the report, RPS may have relied upon information provided to it at the time by other parties. RPS accepts no responsibility as to the accuracy or completeness of information provided by those parties at the time of preparing the report. The report does not take into account any changes in information that may have occurred since the publication of the report. If the information relied upon is subsequently determined to be false, inaccurate or incomplete then it is possible that the observations and conclusions expressed in the report may have changed. RPS does not warrant the contents of this report and shall not assume any responsibility or liability for loss whatsoever to any third party caused by, related to or arising out of any use or reliance on the report howsoever. No part of this report, its attachments or appendices may be reproduced by any process without the written consent of RPS. All enquiries should be directed to RPS.

Prepared by:

Prepared for:

RPS Consulting Services Ltd

Cotefield Holdings Limited

Joanna Gunn
Transport Consultant

20 Western Avenue, Milton Park, Abingdon, Oxfordshire.
OX14 4SH.

T 01235 432 190
E joanna.gunn@rpsgroup.com

Contents

1	INTRODUCTION.....	1
2	EXISTING SITUATION.....	2
3	DEVELOPMENT PROPOSALS.....	11
4	TRANSPORT POLICY AND GUIDANCE.....	13
5	TRIP GENERATION AND PARKING DEMAND.....	20
6	IMPACTS AND OPERATIONAL ASSESSMENT.....	46
7	SUMMARY AND CONCLUSIONS.....	50

Figures and Appendices

FIGURES

FIGURE 1 – SITE LOCATION PLAN

FIGURE 2 – PUBLIC TRANSPORT PROVISION

APPENDICES

APPENDIX A – PROPOSED SITE PLAN

APPENDIX B – CHERWELL DISTRICT COUNCIL COMMENTS

APPENDIX C – PARKING BEAT SURVEY DATA

APPENDIX D – MANUAL CLASSIFIED COUNT DATA

APPENDIX E – AUTOMATIC TRAFFIC COUNT DATA

APPENDIX F – PERSONAL INJURY ACCIDENT DATA

APPENDIX G – TRICS OUTPUT REPORTS

APPENDIX H – TRAFFIC FLOW DIAGRAMS

APPENDIX I – JUNCTIONS 9 OUTPUT REPORTS

1 INTRODUCTION

- 1.1 This Transport Assessment (TA) has been prepared by RPS to support a planning application for a 1235sqm (gross) food store at Cotefield Business Park, Bodicote, with associated access, parking, delivery area and landscaping.
- 1.2 The site layout is attached at **Appendix A**. Full details of the proposed development are included in **Section 3**.
- 1.3 This TA considers the highway and transport matters associated with the proposed development and has been produced in accordance with National Planning Policy Framework; Planning Policy Guidance; the Ministry for Housing, Communities and Local Government's guidance on Travel Plans, Transport Assessments and statements in decision-taking; and Oxfordshire County Council (OCC) guidance on Transport for New Developments: Transport Assessments and Travel Plans (March 2014).
- 1.4 This TA has been prepared following the receipt of comments from Cherwell District Council and Oxfordshire County Council, a copy of which is attached at **Appendix B**. This TA has been prepared in accordance with these comments, and with the guidance included in the NPPF and PPG and OCC guidance
- 1.5 This TA considers the transport aspects of the development proposal. The remainder of the report is divided into the following sections:
- **Section 2:** Existing Situation;
 - **Section 3:** Development Proposals;
 - **Section 4:** Transport Policy and Guidance;
 - **Section 5:** Trip Generation and Parking Demand;
 - **Section 6:** Impacts and Operational Assessment; and
 - **Section 7:** Summary and Conclusions.

2 EXISTING SITUATION

Introduction

- 2.1 This section considers the current site use, location and surroundings. This includes a review of cycling and walking facilities and public transport facilities available for users of the site. It also assesses the local highway network and Personal Injury Accidents (PIAs) on the highway network within the last five years. This information is then summarised and used as a base against which the development proposals are assessed.

Site Use, Location and Surroundings

- 2.2 The site is located at Cotefield Business Park, approximately 3.7km south of Banbury. The site is accessed via a ghost island right turn priority junction from the A4260 Oxford Road which routes north to Banbury town centre and south towards Oxford.
- 2.3 Within Cotefield Business Park, north of the proposed development is Cotefield Garden Centre with two access points from Cotefield Drive. South of the site is JS Auctions, an auction house with monthly antique auctions and viewing days, and quarterly art auctions occurring over two or three days. Jensen International Automotive also occupies one of the units to the south of the proposed development site.
- 2.4 To the immediate southwest of the site is an area of grassland and, further west, an 86-dwelling residential development recently constructed by CALA Homes. As of January 2019, approximately 90% of the units were occupied and it is expected that the site is now at full occupation or as good as full occupation.
- 2.5 To the south of the residential development, another 95 dwelling development has been consented. The development will take approximately 24 months to construct.

Site Access

- 2.6 The site is located immediately west of the A4260 Oxford Road which currently provides access to Cotefield Business Park via a ghost island right turn priority junction. The A4260 Oxford Road is one of the key vehicular routes between Banbury and Oxford. The A4260 Oxford Road routes north to Banbury and south towards Kidlington and Oxford via Adderbury and Deddington.
- 2.7 There is a ghost island right turn lane for vehicles travelling from the north into Cotefield Business Park and a wide give way line from the minor arm to the major arm, allowing a vehicle to turn left whilst another vehicle is waiting to turn right. A central splitter island with dropped kerbs and tactile paving is located in the centre of the minor arm back from the give way line to facilitate a pedestrian crossing point.

Existing Site and Operations

- 2.8 The site is previously developed brownfield land, currently used as a parking area by the adjacent industrial units and construction site. Construction staff use the northern section of the site as a parking zone and construction compound for the adjacent CALA Homes development to the

west. The southern section of the site is used as an overflow car park for the adjacent auction house.

- 2.9 JS Auctions holds monthly specialist auctions of fine art and antiques, with monthly auctions of antique furniture and quarterly auctions of artwork. Auctions start at 10:00, with viewings from 08:00 on the day of the auction. Viewings are from 09:00 to 17:00 the day before, and continue until late, with no fixed end time.
- 2.10 Whilst the proposed development site is currently used as a compound for the adjacent CALA Homes development, the compound will no longer be necessary after construction has been completed and all dwellings all occupied. Additionally, whilst the southern section of the site is currently used as an overflow car park for the adjacent auction house, there are other potential parking locations around Cotefield Business Park, which could be utilised by the auction house during peak times as shown within the parking surveys described later in this section, and in Section 5.

Pedestrian Access

- 2.11 Paragraph 2.3 of the Design Manual for Roads and Bridges TD91/05 ‘Provision for non-motorised users’ states that walking is used to access a wide variety of destinations including educational facilities, shops, and places of work, normally within a range of up to 2 miles. Such a distance captures the majority of the local urban and residential area.
- 2.12 The Chartered Institute of Highways and Transportation (CIHT) publication ‘Providing for Journeys on Foot’ suggests acceptable walking distances for various land uses. These are based on an average walking speed of approximately 1.4 metres / second, which equates to approximately 400 metres in five minutes or 4.8 kilometres per hour as set out in **Table 2.1**.

Table 2.1: CIHT’s Acceptable Walking Distances

Definition	Town centres	Commuting / School	Elsewhere
Desirable	200m	500m	400m
Acceptable	400m	1000m	800m
Preferred Maximum	800m	2000m	1200m

- 2.13 Most residents of Bodicote village centre live within the 1200m preferred maximum walking distances as recommended by CIHT, equating to a maximum fifteen minute walk. Many of the adjacent residential dwellings will be constructed and occupied prior to completion of the proposed food store and will be within this distance to the proposed retail unit. Some residents at Bankside Phase 1 development will be within maximum recommended walking distances.
- 2.14 Within the vicinity of the proposed development site, the A4260 Oxford Road has a footway on the western side of the carriageway which narrows south of the site access junction. There are good levels of street lighting between the development site and Banbury town centre. There is some street lighting on the A4260 south of Cotefield Business Park; however, lighting is only present on the eastern side of the carriageway.

- 2.15 The A4260 routes north onto Weeping Cross, which routes west towards the village centre of Bodicote. The A4260 junction with Weeping Cross is a signalised junction with dropped kerbs, tactile paving and a central island. Weeping Cross is a 30mph residential road with footways and street lighting.
- 2.16 In summary, the site will be well located to allow pedestrian access from Bodicote, the adjacent residential developments which are under construction, and those which are soon to be constructed or will be coming forward as part of the Local Plan.

Cycle Access

- 2.17 A number of off and on road cycle routes are provided in the vicinity of the site, including National Cycle Route 5 located approximately 1.2km from the site. This is accessed via a combination of track roads and off road cycle routes.
- 2.18 National Cycle Route 5 routes along the southern boundary of Banbury, and south through Bodicote and can be accessed via Molyneux Drive / Freemans Road from the site. NCR 5 routes from Banbury through Bodicote, down to Oxford. Locally the route passes along Church Street, the High Street, White Post Road and Bankside.
- 2.19 Cycle lanes are provided on both sides of the carriageway on the A4260 Oxford Road north of Broad Gap, approximately 750m north of the site access junction. North of Mayfield Road these become shared foot and cycleways and provide a link to Sainsbury's and Horton Hospital.

Bus Facilities

- 2.20 Bus stops are located on the A4260 approximately 350m and 500m from the site. Bus services S4 and X4 operate from the A4260 Oxford Road bus stops, facilitating travel in both directions. The S4 operates between Banbury and Oxford from the A4260 adjacent to Weeping Cross with an hourly frequency in both directions. The X4 operates once per morning in each direction between Banbury bus station and Oxford city centre.
- 2.21 An additional stop is located on Weeping Cross, opposite Blackwood Place, from which bus service B3 operates. The B3 operates between Weeping Cross and Banbury town centre with a half hourly frequency.

Air Quality Management Areas (AQMA)

- 2.22 The Department for Environment, Food and Rural Affairs website (<https://uk-air.defra.gov.uk/>) has been accessed to ascertain whether there is an AQMA within the vicinity of the site. The site does not lie within a designated AQMA.

Committed Development

- 2.23 There are a number of committed developments in Banbury, which are to be considered in the traffic impact of the proposed development. Further details of the committed developments that have been assessed are outlined in Section 5 of this report.

Traffic and Parking Surveys

- 2.24 In order to obtain baseline information for Cotefield Business Park and assess the impact of the proposed food store development, traffic surveys were undertaken in late September 2018.
- 2.25 The auction house does not have auctions every weekend, and the number of auction attendees varies with each auction. Based on previous auctions, the client and the auction house operators advised the auctions that occur in late September are typically the busiest auctions to occur annually. Conducting a survey of the maximum potential parking accumulation would enable a robust assessment of the peak vehicle trip generation and parking accumulation that could arise from the existing units at Cotefield Business Park.
- 2.26 The adjacent auction house has viewings prior to an auction, with peak viewings taking place on the Friday preceding the auction between 09:00 and 19:00. Auctions typically take place on Saturdays, with viewings from 08:30 and auctions commencing at 10:00 until late. Online bidding has reduced historical auction attendances by approximately 50%.
- 2.27 Two Manual Classified Counts (MCCs) were undertaken to determine the arrival and departure times and turning movements of vehicles. One MCC was located at the site access junction with the A4260, and another at the Cotefield Nurseries / Cotefield Business Park staggered crossroads. The hours of the MCC survey were Friday 28 September 2018 between 16:00 and 19:00, and Saturday 29 September 2018 peak between 10:00 and 15:00) in line with typical retail peak hours.
- 2.28 In addition, two Automatic Traffic Counters (ATCs) were placed to validate the MCCs and collected data for the seven day period between 26 September and 2 October 2018 on the A4260 south of the site access junction, and on the Cotefield Business Park access road, east of the Cotefield Nurseries access.
- 2.29 Parking beat surveys were undertaken at Cotefield Business Park on Friday 28 September and Saturday 29 September 2018, coinciding with peak viewing and auction times and the ATCs and MCCs. The purpose of the parking beat survey was to determine the parking demand created by each section of the Cotefield Business Park, and to assess whether there would be sufficient capacity to accommodate all vehicles associated with the auction house, should the overflow car park be developed.
- 2.30 The CALA Homes development is almost at full occupation, with contractors, sales team and residents all on site simultaneously. The construction of the housing development will have been completed and fully occupied while the proposed development is being constructed; therefore, the compound currently used by CALA and located on the site will no longer be in use.
- 2.31 The parking beat surveys were proposed to be undertaken between 07:00 and 19:00 on Friday 28 September and Saturday 29 September 2018; however, due to an accident on the M40 on the Friday survey, enumerators were unable to start the survey at the planned 07:00 start, instead starting the survey at 10:30 on Friday 28 September 2018. The Saturday survey was unaffected and undertaken as planned.
- 2.32 The parking beat survey was conducted at various locations around Cotefield Business Park in line with known and potential parking locations for the adjacent units. In total there were 14 potential parking locations across Cotefield Business Park, including small zones where parking

- was not known to occur, but could be a parking location if required. The parking peak survey data and survey locations are shown at **Appendix C**.
- 2.33 Due to the delay in collecting parking survey data, it was not possible to determine the number of vehicles arriving to the site associated with the construction of the adjacent CALA Homes development. The only vehicles which park within the northern section of the development site are vehicles associated with the CALA Homes construction site. These vehicles all arrive prior to any other operations within Cotefield Business Park; therefore, it is reasonable to assume that all vehicles parked in this location at the start of the Friday parking beat survey (at 10:30) are those associated with the CALA Homes construction site.
- 2.34 The CALA Homes construction compound occupies the northernmost half of the overflow car park and contractors and sales staff associated with the development frequently park here. However, construction staff and contractors in private cars frequently park in the auction house overflow section of the car park. As a result, therefore it is not possible to precisely distinguish which vehicles are associated with the construction of the CALA Homes development and which are attributed to the auction house.
- 2.35 A summary of the traffic surveys and parking beat surveys are set out below.

Traffic Flows

Manual Classified Counts

- 2.36 As set out in paragraph 2.27, in order to obtain up-to-date traffic flows along the adjacent highway network, an independent specialist traffic survey company was commissioned to undertake traffic surveys. As shown at **Appendix D**, Manual Classified Counts (MCCs) were undertaken at the following locations:
- A4260 Oxford Road / Cotefield Nurseries Access / Cotefield Business Park staggered crossroads junction; and
 - A4260 Oxford Road / Access Road junction.
- 2.37 The MCCs were fully classified by turning movements and were undertaken on Friday 28 September 2018 over the PM peak period (16:00-19:00), and Saturday 29 September 2018 during the typical retail peak period (10:00-15:00).
- 2.38 The MCCs identified the Friday PM peak hour as being 16:15-17:15 at the site access / Oxford Road A4260 junction. The Saturday peak hour was identified as 12:15-13:15 at the site access / Oxford Road A4260 junction.

Automatic Traffic Counts

- 2.39 The MCCs were validated by the placement of two Automatic Traffic Counters (ATCs) located on the A4260 Oxford Road south of the application site access junction. The ATCs were fully classified and placed for a seven day period (Wednesday 26 September 2018 to Tuesday 2 October 2018). The full data is attached at **Appendix E**, with a summary of the weekday two-way traffic flows on the A4260 shown in **Graph 2.1**.

2.40 An analysis of the ATC data showed that for Monday to Thursday, the PM peak hour was 17:00 to 18:00 in line with typical peak commuter hours. For Friday 28 September, the PM peak hour as recorded by the ATC located on the A4260 Oxford Road was between 16:00 and 17:00. This is shown in **Graph 2.1** and consistent with the MCC data.

Graph 2.1: A4260 Oxford Road ATC Two-way Traffic Flows – Weekday Summary

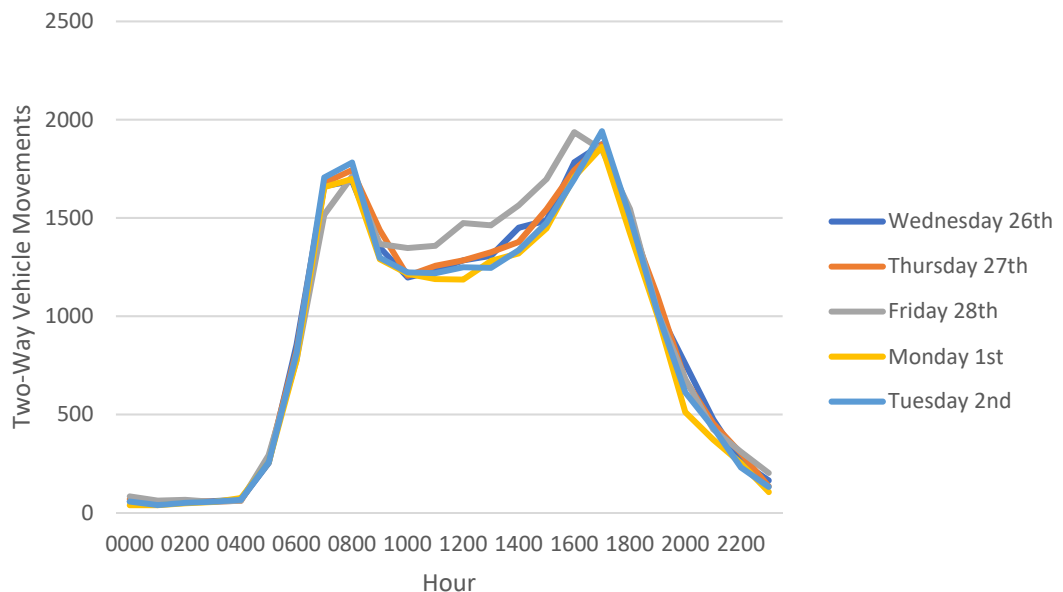

2.41 The ATC data shows the traffic flow variation on a day-to-day basis along the A4260, south of the site access. The observed 24hr weekday traffic flows vary between 20,802 and 22,856 two-way vehicle movements, with a weekday average of 21,804 two-way vehicle movements. The daily profile of weekday vehicle movements remains consistent, with the daily profile for Friday remaining similar in shape but occurring approximately one hour earlier during the interpeak and PM peak period.

2.42 The access road ATC shows fluctuations in two-way daily traffic flows attributed to the business park, construction staff and residents of the adjacent residential development. The full data is attached at **Appendix E** with a summary of the weekday two-way traffic flows shown below in **Graph 2.2**, showing consistent vehicle movements between 06:00 and 08:00 each weekday, with the profile during the interpeak period is inconsistent during the working week. Traffic flows on the site access road are highest on a Thursday and Friday.

Graph 2.2: Site Access Road ATC Two-way Traffic Flows – Weekday Summary



Parking Beat Survey

- 2.43 **Appendix C** sets out the zones surveyed at Cotefield Business Park. Zone 1 is the CALA Homes construction compound, and Zone 2 is the auction house overflow car park which form the boundary of this proposal.
- 2.44 The peak parking accumulation of Zone 2, the auction house overflow car park was 28 vehicles between 13:30 and 15:00 on Friday 28 September as shown in **Graph 2.3**, and 36 vehicles between 11:30 and 12:00 on Saturday 29 September as shown in **Graph 2.4**.
- 2.45 **Graph 2.3** shows a combined maximum parking accumulation of 33 vehicles between 13:30 and 15:00 on the site. **Graph 2.4** shows a combined maximum parking accumulation of 38 vehicles on the site between 11:30 and 12:00.
- 2.46 Upon receiving the parking beat survey data and on discussion with the client and auction house operators, it was apparent that CALA homes construction staff use the auction house overflow car park. Additionally, the start of construction and auction house opening occurs at a similar time and as a result, it is not possible to precisely distinguish which vehicles are construction staff.
- 2.47 Based on the above, it is not possible to accurately determine which vehicles will not be using the site once construction of the adjacent housing development is complete, and which vehicles are visitors to the auction house. The parked vehicles are a mixture of auction house visitors and CALA homes construction staff.

Graph 2.3: Parking Accumulation in Zones 1 and 2 (Friday 28th September 2018)

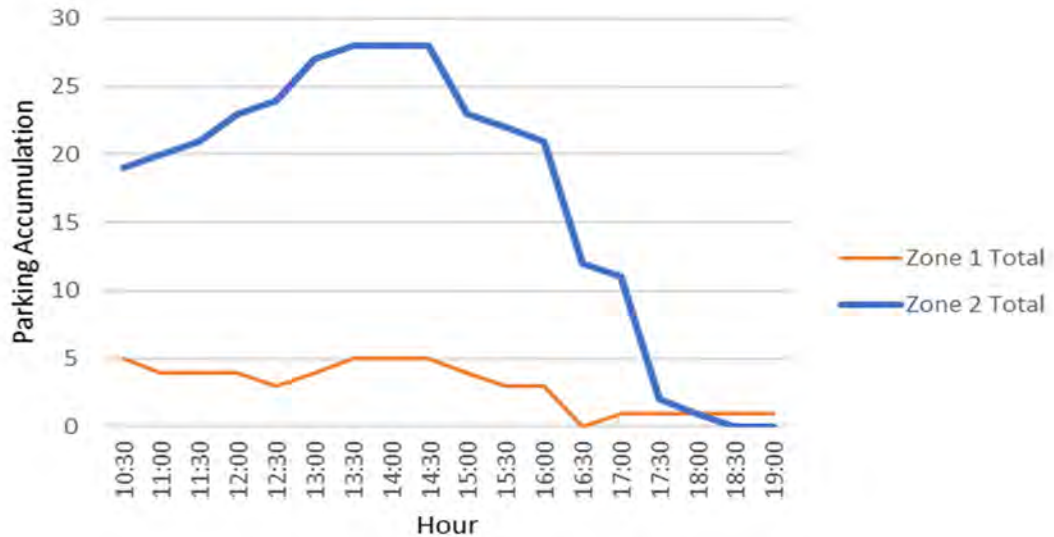

Graph 2.4: Parking Accumulation in Zones 1 and 2 (Saturday 29th September 2018)

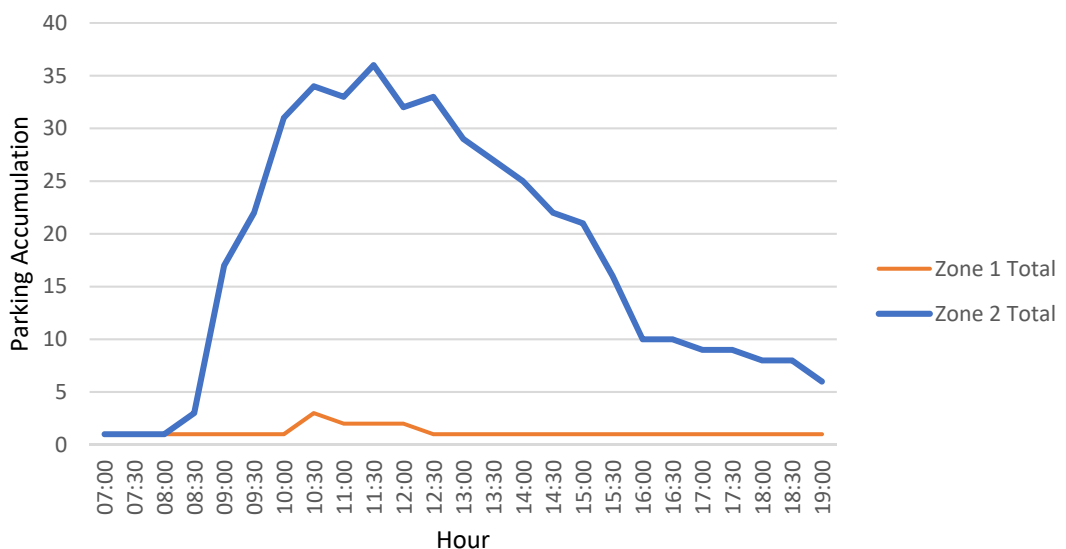

Personal Injury Accident Data

2.48 Personal Injury Accident (PIA) data was requested for a five-year period, although 68 months of data was provided by Oxfordshire County Council for the surrounding highway network within the vicinity of the site. The dates from which data was obtained covers the period 1 September 2013 to 31 August 2018 which was the latest available 5-year data at the time of the request. The OCC PIA output report is attached at **Appendix F**.

-
- 2.49 Additional data to cover the remainder of 2018 was sourced from Crashmap.co.uk, providing a total of 72 months' worth of PIA data.
- 2.50 The area for which PIA was obtained includes the A4260 within approximately 250m to the north, and 300m to the south of the Cotefield Business Park access junction. There were five injury accidents that occurred within the search area during the search time period, of which four were slight injury accidents and one was a serious injury accident. There were no fatal injury accidents. All accidents occurred at different locations with different contributory factors.
- 2.51 The serious injury accident occurred in February 2015 on the A4260 Oxford Road north of the rugby club access, involving two vehicles. A light goods vehicle travelling northbound crossed onto the other side of the carriageway and collided with a taxi travelling southbound on the A4260 Oxford Road.
- 2.52 A slight injury accident occurred on the A4260 to the north of the A4260 Oxford Road approximately 25m north of the rugby club access, involving two vehicles. Another slight injury accident occurred in August 2017 on the A4260 Oxford Road east of Banbury Rugby Club and was a shunt involving two vehicles.
- 2.53 Another slight injury accident occurred in October 2013 at the Weeping Cross / A4260 Oxford Road junction. A car turning right from Weeping Cross onto the A4260 Oxford Road failed to give way to a vehicle travelling northbound on the A4260 Oxford Road.
- 2.54 The final slight injury accident occurred on the A4260 Oxford Road approximately 300m south of the access junction, where a car travelling northbound failed to negotiate the road bend due to a medical incident.
- 2.55 From the analysis undertaken it appears that driver error was the common contributory factor and that there are no aspects with the local highway network that suggests it contributes to a road safety issue.

Summary

- 2.56 This section has demonstrated that the proposed development is located in a sustainable and accessible location for all modes of transport. There are a number of bus routes service the nearest bus stops to the site. Various residential areas such as Bodicote are currently within recommended maximum walking and cycling distance of the site, with more residential developments coming forward over the next few years.
- 2.57 PIA data demonstrates a low level of injury accidents on the surrounding roads and junctions.

3 DEVELOPMENT PROPOSALS

- 3.1 The development proposals are for a 1235sqm GFA food store at Cotefield Business Park, with associated access, car parking, delivery area and landscaping on a parcel of land on the southern edge of the settlement of Bodicote, around 1km from Bodicote village centre.
- 3.2 The site currently serves as overflow parking for the auction house at Cotefield Business Park and previously served as a construction compound for the adjacent housing development. The site is bound to the south by units at Cotefield Business Park and to the north by the Cotefield Business Park access road.
- 3.3 The proposed food store will serve Bodicote and the surrounding area, and capture pass-by trips for commuters along the A4260. As detailed in the Retail Impact Assessment (RIA), it is not thought likely that the catchment of the proposed store will extend very far north into Banbury. For context, the RIA considers the catchment area to be south Banbury and not north beyond the existing Sainsburys approximately 2km north of the site.
- 3.4 The size of store being proposed will cater for top-up and an element of main food shopping. The site will also serve as a local food store for the nearby Bankside development which is currently under construction, and Bankside Phase 2 should this be constructed.
- 3.5 This chapter outlines the proposals for the development site, the vehicular access arrangements, the internal provision for pedestrian and cyclist movements and the measures being promoted to encourage sustainable travel.

Vehicular and Pedestrian Access

- 3.6 Vehicular access to the proposed development will be taken from the existing access to Cotefield Business Park, taken via the ghost island right turn priority junction from the A4260 Oxford Road.
- 3.7 The proposed internal arrangement of paths in the proposed development will be designed to similar standards and principles to those of the west-adjointing consented development. This will therefore provide continuity between the adjacent residential developments and will create a safe environment for all pedestrians. A separate pedestrian access will be provided onto the A4260 Oxford Road for direct pedestrian access.

Deliveries and Refuse Collection

- 3.8 The internal road network to Cotefield Business Park is designed to facilitate the manoeuvrability and navigation of refuse vehicles and emergency service vehicles throughout the development. A service yard is located to the south of the proposed supermarket to enable Heavy Goods Vehicles (HGVs) to manoeuvre for deliveries in a safe manner within the site boundary.

Car and Cycle Parking

- 3.9 The food store car park will operate a one-way system to enable vehicles to turn left into the car parking area and manoeuvre within the site. 86 spaces will be allocated adjacent to the food store of which four will be disabled parking bays. Cycle parking will be provided in accordance with parking standards.

- 3.10 Oxfordshire County Council does not have documented standards for food retail parking allocation requirements. The precise amount of car parking will be determined according to the specific characteristics of the development and its location. Proposals should not prejudice road safety or significantly inconvenience the flow of traffic.
- 3.11 Parking standards are set out in Section 4: Transport Policy and Guidance. The site will provide 86 car parking spaces in line with the guidance available.
- 3.12 With regard to parking space dimensions, standard car parking spaces will be 2.5m by 5m.

Construction Traffic

- 3.13 Construction of the development would be similar to the construction works currently ongoing with the adjacent residential units. These vehicle movements are currently accommodated on the highway network, within the site and alongside existing the existing site operations, inclusive of auction days.

4 TRANSPORT POLICY AND GUIDANCE

- 4.1 This section details the transport policy documents against which the development proposals will be considered from national and local guidelines.

National Policy

National Planning Policy Framework

- 4.2 National policy in relation to the transport planning of developments is set out in the National Planning Policy Framework (NPPF). Section 9, 'Providing Sustainable Transport', states the following;
- 4.3 Paragraph 108 states that:
- "In assessing site that may be allocated for development in plans, or specific applications for development, it should be ensured that:
- appropriate opportunities to promote sustainable transport modes can be – or have been – taken up, given the type of development and its location;
 - safe and suitable access to the site can be achieved for all users; and
 - any significant impacts from the development on the transport network (in terms of capacity and congestion), or on highway safety, can be cost effectively mitigated to an acceptable degree."
- 4.4 Paragraph 109 states that:
- "Development should only be prevented or refused on highway grounds if there would be an unacceptable impact on highway safety, or the residual cumulative impacts on the road network would be severe."
- 4.5 Paragraph 111 states that:
- "All developments that will generate significant amounts of movement should be required to provide a travel plan, and the application should be supported by a transport statement of transport assessment so that the likely impacts of the proposal can be assessed."
- 4.6 With regard to parking, Paragraph 105 of the NPPF states that:
- "If setting local parking standards for residential and non-residential development, policies should take into account:
- the accessibility of the development;
 - the type, mix and use of the development;
 - the availability of and opportunities for public transport;
 - local car ownership levels; and
 - the need to ensure an adequate provision of spaces for charging plug-in and other ultra-low emission vehicles."

4.7 Paragraph 106 states that:

“Maximum parking standards for residential and non-residential development should only be set where there is a clear and compelling justification that they are necessary for managing the local road network, or for optimising the density of development in city and town centres and other locations that are well served by public transport (in accordance with chapter 11 of this Framework). In town centres, local authorities should seek to improve the quality of parking so that it is convenient, safe and secure, alongside measures to promote accessibility for pedestrians and cyclists.”

Planning Practice Guidance (PPG) ‘Travel Plans, Transport Assessments and Statements in Decision-Taking’ (March 2014)

4.8 *Planning Practice Guidance - Travel Plans, Transport Assessments and Statements in Decision-Taking* provides a concise report on the use and importance of Transport Assessments / Statements and Travel Plans. With regard to whether to provide a Transport Assessment, Transport Statement or no assessment, the guidance states that:

“Local planning authorities, developers, relevant transport authorities, and neighbourhood planning organisations should agree what evaluation is needed in each instance.”

4.9 The guidance states that Transport Assessments / Statements and Travel Plans can positively contribute to;

- “encouraging sustainable travel;
- lessening traffic generation and its detrimental impacts;
- reducing carbon emissions and climate impacts;
- creating accessible, connected, inclusive communities;
- improving health outcomes and quality of life;
- improving road safety; and
- reducing the need for new development to increase existing road capacity or provide new roads.”

4.10 The guidance states that Transport Assessments / Statements and Travel Plans should be proportionate to the size and scope of the proposed development, be tailored to particular local circumstances and be established at the earliest practicable possible stage of a development proposal.

4.11 The guidance continues by stating that these reports should be brought forward through collaborative ongoing working between the Local Planning Authority / Transport Authority, transport operators, Rail Network Operators, Highways Agency and other relevant bodies.

4.12 With regard to parking, the guidance moves away from the use of maximum parking guidance and Paragraph 008 states that:

“Maximum parking standards can lead to poor quality development and congested streets, local planning authorities should seek to ensure parking provision is appropriate to the needs of the development and not reduced below a level that could be considered reasonable.”

Local Policy

- 4.13 National policy on transport and land use establishes broad policy objectives that reflect the Government's aspirations for integrating land development and transport. The role of local government is to develop strategies based on specific local, social and spatial requirements, which deliver national aspirations.
- 4.14 Local strategy with respect to land use and transport is articulated in statutory documents prepared by planning and highway authorities which, for this development, comprise of the following:
- Oxfordshire County Council's Connecting Oxfordshire Local Transport Plan 2015-2031 (2015); and
 - The Cherwell Local Plan 2011 – 2031 (adopted July 2015).
- 4.15 In the absence of applicable food retail parking standards in the Cherwell Local Plan, advised parking standards are taken from the following documents;
- West Oxfordshire Local Plan 2031 – Adopted September 2018; and
 - Parking Standards - Supplementary Planning Guidance Adopted by Vale of White Horse Council (July 2006).

Oxfordshire County Council Connecting Oxfordshire Local Transport Plan 2015-2031 (adopted 2015)

- 4.16 The Connecting Oxfordshire Local Transport Plan (LTP4), sets out Oxfordshire County Council's policy and strategy for developing the transport system in Oxfordshire to 2031. It has been developed with input from Oxfordshire's district and city councils, its businesses, MPs, stakeholder groups and through public consultation.
- 4.17 Connecting Oxfordshire has been developed with these three over-arching transport goals (economy, environment and society), as set out in 'Volume 1: Policy & Overall Strategy':
- "To support jobs and housing growth and economic vitality;
 - To reduce transport emissions and meet our obligations to Government;
 - To protect, and where possible enhance Oxfordshire's environment and improve quality of life (including public health, safety and individual wellbeing.)"
- 4.18 Paragraph 122 of the LTP4 states the following:
- "It is vital that all of Oxfordshire's residents have an opportunity to contribute to, and benefit from, the economic success that is forecast for the county over the period of this Plan, whether or not they have access to a private car. Above all this requires access to education and jobs, but also to retail, leisure, culture, and health services. For short trips, access can be significantly improved through better walking and cycling links. When developing walking and cycling networks for towns, we will ensure that they include connections to areas that are less well served by public transport, and in particular, areas with higher levels of deprivation."

- 4.19 The Connecting Oxfordshire: Local Transport Plan 2015 – 2031 Volume 8, part ii document sets out, amongst other issues, the Banbury, Bicester, Carterton, Science Vale & Science Vale Cycle Strategy and Witney Area Strategies.
- 4.20 Policy BAN1 states the following:
- “We will seek opportunities to deliver transport schemes which will support the regeneration and growth of Banbury to 2031 and protect the historically sensitive areas of the town through:
- Promotion of Bankside;
 - Traffic management along A361 the South Bar Street/ Horsefair corridor;
 - Bridge Street/ Cherwell Street eastern corridor improvements;
 - Bloxham Road (A361)/ South Bar Street improvements;
 - Provision of A361 Bloxham Road to A4260 Oxford Road Spine Road
 - Hennef Way/ Southam Road improvements;
 - Hennef Way/ Concord Avenue improvements;
 - Hennef Way/ Ermont Way improvements;
 - Ermont Way/ Middleton Road improvements;
 - Increasing the capacity of junctions along Warwick Road (B4100);
 - Bloxham Road (A361) junction with Queensway and Springfield Avenue improvements;
 - A361 Southam Road junction with Castle Street and Warwick Road improvements;
 - Provision of a link road East of M40 Junction 11 (Overthorpe Road to A422);
 - Investigating the impact of i) a link road crossing from Tramway Road to Higham Way; ii) a link road from Higham Way to Chalker Way at Central M40 site; iii) a road linking Higham Way to Thorpe Way; iv) a south east link road;
 - Reviewing the highway signage on routes into the town centre to sign north-south through-traffic away from sensitive areas of the town centre and promote appropriate route choices at key decision making junctions;
 - A car park review and improvements, and provision of car park matrix signs.”
- 4.21 The promotion of Bankside as a site for residential development increases the number of dwellings which will utilise the proposed development as a local supermarket. Additionally, the provision of A361 Bloxham Road to A4260 Oxford Road Spine Road, to be paid for by the developer of the residential development South of Salt Way, will support operation of commercially viable bus services through the development, increasing accessibility and long term sustainability of the development.
- 4.22 The above policy extracted from the Oxfordshire County Council Connecting Oxfordshire Local Transport Plan 2015-2031 (September 2014) demonstrates that the site is suitably located to provide a valuable local supermarket for the hundreds of residential dwellings to be developed as part of the Local Plan. Additionally, transport scheme improvements and the provision of the

A361 Bloxham Road to A4260 Oxford Road Spine Road will enable more residents to cycle to the proposed food retail units.

The Cherwell Local Plan 2011 – 2031 Part 1 (adopted July 2015)

- 4.23 The Cherwell Local Plan 2011 – 2031 Part 1 (adopted July 2015) (incorporating Policy Bicester 13 re-adopted on 19 December 2016) sets out their proposals to support the local economy and communities over the next few decades. It is a plan which seeks to ensure that growth is targeted in the most sustainable locations, focusing on housing growth in Bicester and Banbury and to ensure that the level of development within local villages respects the character and beauty of rural areas while meeting local needs.
- 4.24 There is limited information regarding transport policy within the Cherwell Local Plan; however, there are details of specific strategic development sites which are within the vicinity of the proposed development.
- 4.25 Policy Banbury 4: Bankside Phase 2 is a development area of 27 hectares with 600 homes with associated services, facilities and other infrastructure located to the east of the A4260. The development will change the existing rural character of the area north-east of Bodicote on the eastern side of Oxford Road but will provide much needed family homes, including affordable housing. It will also bring about new services and facilities, canal side facilities, and an extensive area of public open space. As part of the additional development, educational facilities, open space including greenspace, playspace, allotments and outdoor provision will be provided to the south, known as Policy Banbury 12: Proposed Banbury United FC Relocation.
- 4.26 There will be a provision of vehicular, cycle and pedestrian access directly from the Banbury 4 site into site Banbury 12 and a provision of vehicular, cycle and pedestrian access directly from the site into site Banbury 12. A bus route extension from Phase 1 (an approved housing scheme to the immediate north) will also be provided.
- 4.27 Part of Bodicote village is designated as a conservation area as per the adopted local plan. Strategic housing sites and approved housing sites occupy much of the eastern side of the A4260 between Banbury town centre and the proposed development site; therefore at present the site and proposal is well situated to serve as a local food store in an area in which is proposed to have hundreds of houses as part of a long-term development plan.
- 4.28 Policy SLE 4: Improved Transport and Connections sets out the following:
 “All development where reasonable to do so, should facilitate the use of sustainable modes of transport to make the fullest possible use of public transport, walking and cycling. Encouragement will be given to solutions which support reductions in greenhouse gas emissions and reduce congestion. Development which is not suitable for the roads that serve the development and which have a severe traffic impact will not be supported.”
- 4.29 The proposed development site is currently well situated to capture commuter traffic from the A4260 and will result primarily in pass-by trips rather than adding new trips onto the road network; therefore, it is suitable for the roads that serve the development. Additionally, the proposed improvements in sustainable transport provision as part of the local plan means that in future, the site will serve as a local food store for a growing residential area, for which sustainable modes of transport between new homes and the proposed development site is a viable option.

- 4.30 The location of the site in transport terms is accessible by bus and cycle, and within The Chartered Institute of Highways and Transportation (CIHT) publication '*Providing for Journeys on Foot*' suggested maximum walking distances for residents of Bodicote. As additional sustainable transport infrastructure becomes available as the strategic housing sites are developed, the sustainability of the site in terms of transport and accessibility will become increasingly important.

Car Parking and Cycle Parking Standards

- 4.31 Oxfordshire County Council and Cherwell District Council do not have documented policy standards for non-residential land uses, and each application is considered on its merits.
- 4.32 In the absence of non-residential parking standards, non-residential parking standards for other District and Borough Councils within Oxfordshire are detailed below to provide a guide for food retail parking standards.

West Oxfordshire Local Plan 2031 – Adopted September 2018

- 4.33 The West Oxfordshire Local Plan 2031 was formally adopted in September 2018. The Local Plan determines the level of provision in accordance with the residential, non-residential and cycle parking standards adopted by Oxfordshire County Council as the highway authority. The residential parking standards are based on the provision of an 'optimum' number of spaces rather than a 'maximum' or 'minimum' and are based on the provision of a mix of allocated and unallocated spaces.
- 4.34 The West Oxfordshire Local Plan 2031 sets out that its parking policy will follow the level of provision in accordance with the residential, non-residential and cycle parking standards adopted by Oxfordshire County Council as the highway authority; however, there are no documented standards for non-residential developments.
- 4.35 The West Oxfordshire Local Plan 2011 – adopted in 2006, set out the maximum car parking Standards for West Oxfordshire (Zone C – small towns) as 1 space per 14m² for food retail, there was a presumption that the standards will also apply to developments below the threshold size of 1000m², but each case will be considered on merit with regard to the availability of public transport and accessibility of the site to pedestrians and cyclists.
- 4.36 Thresholds are set out in PPG13 (Transport). Trip generation and Parking Demand, and a strict PPG6 (sequential test) locational policy would apply to food and non-food retail developments. These parking standards were superseded by The West Oxfordshire Local Plan 2031; however, the one parking space per 14m² appears to have been standard guidance prior to the Oxfordshire County Council's Local Transport Plan 2015-2031.

Parking Standards - Supplementary Planning Guidance Adopted by Vale of White Horse Council (July 2006)

- 4.37 The Vale of White Horse District Council covers the area of Oxfordshire which incorporates towns such as Abingdon, Faringdon and Wantage. The Supplementary Planning Guidance: Parking Standards – Maximum levels states that for food retail, there should be one space per 14sqm GFA for sites above the application threshold of 1000sqm.

- 4.38 Supplementary Planning Guidance documents give more details on specific policies included in the existing Local Plan 2011. Although they are not part of the Local Plan, they should be read in conjunction with it and can be taken into account as a material consideration in determining planning applications.

Non-Statutory Cherwell Local Plan 2011 (not adopted – Dated December 2004)

- 4.39 The Non-Statutory Cherwell Local Plan 2011 was intended to review and update the Local Plan adopted in 1996. Due to changes to the planning system introduced by the Government, work on this plan was discontinued prior to adoption. The Non-Statutory Cherwell Local Plan 2011 is not part of the statutory development plan but was approved as interim planning policy for development control purposes in December 2004.
- 4.40 The Non-Statutory Cherwell Local Plan 2011 was an interactive plan and details the parking standards for non-residential developments online. Although the guidance was not adopted, it set out parking standards for food retail are 1 space per 14sqm for developments that exceed a 1000sqm threshold.

5 TRIP GENERATION AND PARKING DEMAND

5.1 This section considers the likely trip generation of the proposed food store and the distribution of those trips on the local highway and transport networks. The vehicular trips associated with the proposed development have been generated through an interrogation of the Trip Rate Information Computer System (TRICS Version 7.6.3) database for similar sites.

Trip Generation

5.2 To calculate the number of vehicular trips generated by the 1235sqm food retail unit, vehicular trips have been obtained from an interrogation of the TRICS database for sites with similar characteristics to those of the proposed development.

Food Retail Land Use

5.3 The TRICS database has three land use categories pertaining to food retail:

- A – Food Superstore: “A single food superstore with or without a petrol filling station as part of the site. May be part of a retail park, but site details and survey will only include the food superstore (and PFS if present) element. There may also be small shop units as part of the site. However, if the small shop units constitute more than 15% of the total Gross Floor Area of the site the site should be classified as 01/I, 01/J, or 01/M”;
- C - Discount Food Store: “A single discount food superstore offering customers cheaper food, often sold in bulk packaging. May be part of a retail park, but site details and survey will only include the discount food store element”;
- O – Convenience Store: “Small “corner shop” style store or small “local” version of a major retailer store, selling various items which may include groceries, newspapers and magazines, confectionery, and household products”.

5.4 The parameters used include land use ‘01 – Retail’ and category ‘A – Food Superstore’ as the site does not fall under the discount food store, categorised as “a single discount food superstore offering customers cheaper food, often sold in bulk packaging.” There is potential for the proposed site to fall under both ‘Food Superstore’ and ‘Convenience Store’ land use categories; however, the site is a single food store, a standalone unit with associated car parking and is not a smaller version of a major retailer. Based on the above, the proposed food store is classified as a Food Superstore within the TRICS database.

5.5 Comparatively, the TRICS database generates a greater rate of total person movements for a convenience store; however, the modal split of a convenience store sees a greater percentage of the modal split represented by pedestrians.

5.6 The proposed food store is 1235sqm GFA located just off the A4260 Oxford Road, one of the primary commuter roads between Banbury and Oxford. As such, the site is suitably located to capture vehicle trips already on the A4260 Oxford Road. The modal split of a superstore which typically sees a greater percentage of vehicle trips is applicable to the typical modal split likely to occur at the proposed development.

5.7 The full TRICS output report is attached at **Appendix G**.

Trip Generation

- 5.8 Trips have been generated based on a scheme design of 1235sqm GFA and are detail in **Table 5.1** below.

Table 5.1: Food Retail - TRICS Trip Rates

	Friday PM Network Peak 16:00-17:00			Friday PM Development Peak 17:00-18:00			Saturday Peak 12:00- 13:00		
	In	Out	Two-way	In	Out	Two-way	In	Out	Two-way
Total Person Trip Rate	14.314	13.671	27.985	15.17	16.759	31.929	10.209	10.485	20.694
Total Person Trips	177	169	346	187	207	394	126	129	256
Vehicle Trip Rate	8.495	7.906	16.401	9.459	9.727	19.186	5.033	5.176	10.209
Vehicle Trips	105	98	203	117	120	237	62	64	126

- 5.9 **Table 5.1 and Appendix G** shows that the Friday development peak hour vehicle trip generation is anticipated to occur between 17:00 and 18:00, with 117 arrivals and 120 departures totalling 237 two-way vehicle movements. **Table 5.1** shows that an estimated 126 two-way vehicle movements occur during the Saturday network peak hour.
- 5.10 The traffic survey data identified the Friday PM network peak hour as 16:00 to 17:00 and would remain as such with the addition of development traffic; therefore the network peak hour of 16:00 to 17:00 has been assessed.
- 5.11 **Appendix G** shows that the Saturday development peak hour vehicle trip generation is anticipated to occur between 16:00 and 17:00, with 73 arrivals and 64 departures totalling 137 two-way vehicle movements. The traffic survey data identified the Saturday network peak hour as 12:00 and 13:00 and the combined peak would occur between 12:00 and 13:00.
- 5.12 Given the nature of the proposed development site and its location on a primary commuter road from Oxford to Banbury, a high proportion of the proposed development vehicle trip generation will consist of pass-by and transferred trips. These are detailed in the paragraphs below.

Pass-by, Transferred and Diverted Trips

- 5.13 The proposed food store is located on a primary commuter road and a proportion of pass-by, diverted and transferred trips will occur as a result. The Department for Transport (DfT) document 'Guidance on Transport Assessment' (March 2007), although withdrawn, states that the level of reduction in vehicular trip generation based on the mix of trips "will be to a degree subjective and dependent on the specific characteristics and location of the proposed development."
- 5.14 Pass-by, diverted and transferred trips are defined below as per the TRICS Research report 14/1 'Pass-By & Diverted Trips':

- “Pass-by trips are already present on the road network directly adjacent to accesses to a development, which will turn into the Site. If it can be clearly demonstrated that there will be a proportion of true pass-by trips that were already on the network, then these can be deducted from the calculated generation for a development.
 - Diverted trips are already present on the local road network but not the road(s) from which access is taken and would divert from their existing route to access the development. They are similar to pass-by trips, but have to deviate to make use of a development. Diverted trips will tend to return to their original route after visiting the development. It is important to identify the potential for such diversion to occur so as to ensure that the correct flows are assessed at specific junctions on the highway network.
 - Transferred trips are already present on the local road network, accessing similar existing sites in close proximity to the proposed development and will have the potential to transfer their destination to the proposed development. These are slightly different from diverted trips as these wholly transfer from using an existing development to a new one, e.g. shoppers switching to a new supermarket that is more conveniently located for them.”
- 5.15 The TRICS Research Report 14/1 ‘Pass-By & Diverted Trips’ considers questions and reviews of research that has been carried out since 1995 on pass-by and diverted trips and supersedes the 95/2 TRICS Research Report. The report summary concludes with the following:
- “It is recognised that there is no simple answer in determining the percentage of trips to a site that are pass-by or diverted. It is therefore recommended that a site-by-site approach is taken in assessing the prevalence of pass-by and diverted trips.”
- 5.16 The TRICS Research report 14/1 ‘*Pass-By & Diverted Trips*’ draws upon commercial and academic research spread across several disciplines, and the findings are set out in the report. Each piece of academic research is detailed in the following paragraphs.
- Somerfield: Shopping Trip Survey (1996)**
- 5.17 The first piece of research reviewed in the TRICS report is the Somerfield Shopping Trip Survey (1996), which carried out customer surveys at 33 stores with different location characteristics. The purpose was to identify level linked expenditure undertaken by Somerfield shoppers in a variety centre types, the extent to which linked trips vary with location; and beneficiaries of linked spending. The sample was selected to reflect the different sizes of town centres, from sub regional to small district and local centres. The survey results indicate that pass-by and diverted trips is a significant feature of retail shopping in many centre, with 46% of the surveyed customers visiting another shop in a town centre on the same trip as that to Somerfield.
- “However, the amount of linked expenditure varies depending on the type of town centre, as shown in the figure below. In-town stores generate the highest average linked spend (46p per pound spent in Somerfield), followed by edge-of-centre stores at 21p per pound spent at Somerfield.”
- 5.18 A summary of the findings are summarised in the TRICS Research report 14/1 and are summarised in **Figure 5.1**.

Figure 5.1: Amount of Linked Spending per £1 spend in Somerfield

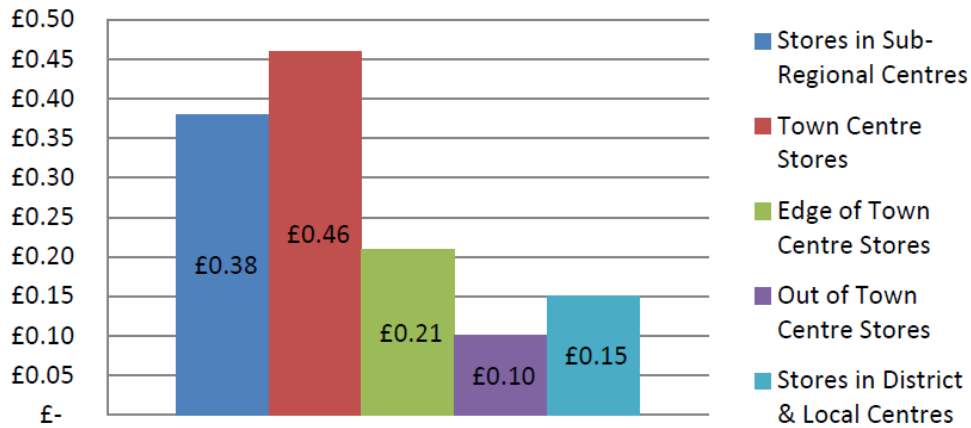

5.19 Alongside the extent to which a store compliments a town centre, the study recognised additional factors influencing pass-by and diverted trips such as facilities within the town and shop size.

Bennison et al. (2000) Linked Shopping Trips: a report for Tesco Stores Ltd.

5.20 An additional review of academic research, the Bennison et al. (2000) “Linked Shopping Trips: a report for Tesco Stores Ltd” was reviewed within the TRICS report; however, the report was unpublished and only provided a summary of the findings and does not set out any details on factors such as site location, catchment or store size. As a result, the findings of this report are as follows:

“The study concluded that linked trips do exist but that the majority of grocery shopping trips do not have a linked trip associated with them; in other words, they can be seen as primary trips. The propensity for linked trips depends on the location of the foodstore and tends to decrease as the distance between the store and town centre increases.”

Tesco Survey: Shopping Centres Research – Linked Trips Information, 2001

5.21 Tesco Stores Ltd commissioned research into linked trips between a number of its food stores and town / district centres. The research was undertaken in May and June of 2001 and consisted of interview surveys leaving six Tesco stores located in existing shopping centres.

5.22 Whilst the report found that the average proportion of linked trips between the store and the town / district centre was 49%, with the range of values being from 34% (Milton Keynes) to 66% (Stevenage), this was conducted within existing shopping centres. The proposed food retail unit will be a standalone store in an edge of town location; therefore the range in linked trips quoted in this piece of commercial research is not directly applicable to the proposed development.

Harries et al. (2012) Trip Generation Characteristics of Large-Format Retail Development Sites in Auckland

- 5.23 TRICS Research report 14/1 summarises that this academic research found that a high proportion of secondary (pass-by and diverted) trips exist, being in the range of 57-67% at a supermarket and home improvement warehouse.
- 5.24 The data obtained for this research was conducted in New Zealand for a mixed retail use site; therefore the research findings have therefore not been considered to have any relevance to the proposed development.

Ghezawi et al. (1998) Convenience Store Trip Generation

- 5.25 Academic research on convenience store trip generation written conducted by Ghezawi et al. (1998) is referenced in the TRICS Research report 14/1. The report states that there is an interesting issue relating to the trips generated by convenience stores, which involves pass-by trips. If pass-by trips are assumed to be impulsive stops along predetermined routes, then these trips generated by sites such as convenience stores can be estimated based on the traffic volumes on adjacent roads:
- “This study aimed to develop mathematical models for estimating traffic generated by convenience stores using data collected at 26 stores. Two sets of equations were developed, one for all trips and one for pass-by trips only.
 - 13 of the 26 convenience stores were selected for a questionnaire survey to assess the percentage of pass-by trips. A total of 571 interviews were undertaken with questions designed to determine whether a trip made to the store was a primary trip, a diverted trip or a pass-by trip.
 - The average percentage of pass-by trips recorded was 72%, with a range between the 13 stores of 61 to 85%. The study also found a positive relationship between pass-by trip percentage and adjacent street volumes using average daily traffic flows.
 - The paper recognises that pass-by trips are important to recognise when assessing the impact that a development will have on the surrounding street system since they already exist on the road network.”
- 5.26 The above research does not establish the link between location (i.e. edge of town or intermediate location) and pass-by trips. Although the site is in an edge of town location, based on the above it is well situated on the A4260 Oxford Road to capture impulse stops.

Wrigley (2006) The Effects of Corporate Foodstores on the High Street: Rebalancing the Debates, University of Southampton

- 5.27 The report considered two food stores located in edge of town centres locations at Beverley in East Yorkshire and Warminster in Wiltshire. The research summary is as follows:
- “Research into the level of linked trips occurring between the stores and adjacent town centres indicated that a high level of linked trips combining food shopping and the use of other town centre shops and servicing were taking place. The level of linked (diverted) trips recorded at both locations was in the region of 60% (65% at Beverley, 58% at Warminster).”

National Retail Planning Forum Scoping Paper, 2004

- 5.28 The National Retail Planning Forum (NRPF) commissioned the Oxford Institute of Retail Management in 2004 to produce a report considering the issue of linked trips; however, the academic review of this research was that there were a number of gaps within the research, and that location data was often location specific and is often unavailable in the public domain. “Where such survey data is available, data on diverted trips is often fragmented and unanalysed.”

Mouchel (2009) Proposed Tesco Store & Shopping Centre, West Bromwich: Working Paper 3 – Linked Trips

- 5.29 This piece of academic research focused on the potential for linked trips between town centre locations and food stores.

- 5.30 Research into the level of linked and pass-by trips which could be generated by a new Tesco store in West Bromwich Town Centre was produced by Mouchel (2009), summarised in TRICS Research report 14/1 below.

- “In order to determine the level of linked trips likely to occur at the Tesco store, a number of research papers on linked trips were investigated. It is argued that this research, much of which has been detailed above, demonstrates a high level of linkage between town centres and foodstores, with the level of linked trips ranging from 34% to 66% (Tesco Stores Ltd., 2001) and the majority of cases having a level of linked trips with adjacent town and shopping centres at above 60%.
- “To provide a robust assessment however, a proportion of linked trips between the Tesco store and shopping centre of 50% was proposed, a figure argued to be “significantly below that which could be achieved given the results ... within the available research.
- “It is recognised within the working paper that the level of pass-by trips generated by the store would vary across the day and also from weekday to weekend. A pass-by level of 40% was accepted to be a robust estimate during the weekday PM peak period.”

- 5.31 The proposed food store is located within an edge of town area adjacent to a primary commuter road. The range of pass-by trips summarised in this piece of academic research will not be directly applicable to the proposed food retail unit; however, the level of pass-by trips generated by the proposed development is anticipated to vary across the day, and from weekday to weekend.

Aslop Verrill (2007) Planning and Retail Statement, Quay Street, Fareham

- 5.32 A Planning and Retail Statement to support a planning application by Tesco Stores Ltd. for a retail food store development in Fareham was undertaken, with the methodology using telephone surveys to investigate the shopping habits of residents within the catchment area. The TRICS Research report 14/1 summarises the research as follows:

“The survey found that the majority of trips to do main food shopping are single purpose journeys (primary trips). 89.8% of trips originated at home, and 97.4% ended at home. 79.4% of respondents did not carry out any other activities while completing their main food shop. Data from the survey confirms that, generally speaking, town centre foodstores have a higher incidence of linked trip activity.”

Maclver, A. (1999) Transportation Impact Assessment: Forecasting Travel Demand

5.33 Maclver.A. (1999) states that whilst methodologies for estimating trip generation rates are well established as a result of major data collection programmes, experienced transportation engineers have become extremely astute at predicting trip rates for new developments. However; it is evident that trip distribution methodology is far from being clearly understood by practitioners.

5.34 Maclver defines primary trips as simple trip chains made from home, and the methodology used to estimate trip distribution of primary trips is well developed. Maclver then details that secondary trips are of interest, primarily due to the fact that they can be discounted during the assessment of traffic impact on the local road network.

“Previous trip type surveys have indicated that on average 70% of pass-by trips during the evening peak originated at work. The increase in pass-by trip proportions during this period can largely be attributed to these work trips. Although pass-by trips do occur at other times of the day they are not usually work-based, but involve other purpose.”

5.35 TRICS Research report 14/1 Paragraph 6.40 states that Maclver recommends that the following general rules are used for determining the proportions of pass-by trips at superstore developments in the United Kingdom:

- “For superstores located on major commuting routes in larger urban areas, the pass-by proportion may range between 25-35% depending on the levels of traffic flow. It may be assumed that more populous urban areas will generate higher levels of pass-by trips;
- On other less significant commuting routes, in out-of-town locations and in urban areas with smaller populations, the pass-by proportion can be assumed to be in the range of 15 to 25%;
- In town centres and on non-primary routes the proportion will be approximately 10%; and
- In locations with little propensity to generate pass-by trips the proportion can be as low as 5%.”

TRICS Research report 14/1: Pass-By & Diverted Trips Assessment Methodology

5.36 The TRICS Research report 14/1, section 11: Pass-By & Diverted Trips Assessment Methodology states that a generic standard reduction is no longer applicable – instead a level of reduction should be determined on a site-by-site basis.

5.37 The methodology states the following:

“A store’s location type can influence both the daily trip rate and percentage of secondary (pass-by and diverted) trips. As a store’s proximity to a town centre increases, the potential percentage of pass-by trips also increases.”

5.38 The methodology uses a graph, shown in **Figure 5.2**, to demonstrate a linear relationship between site location and the pass-by trips percentage.

Figure 5.2: Relationship between Site Location and Pass-by Trips

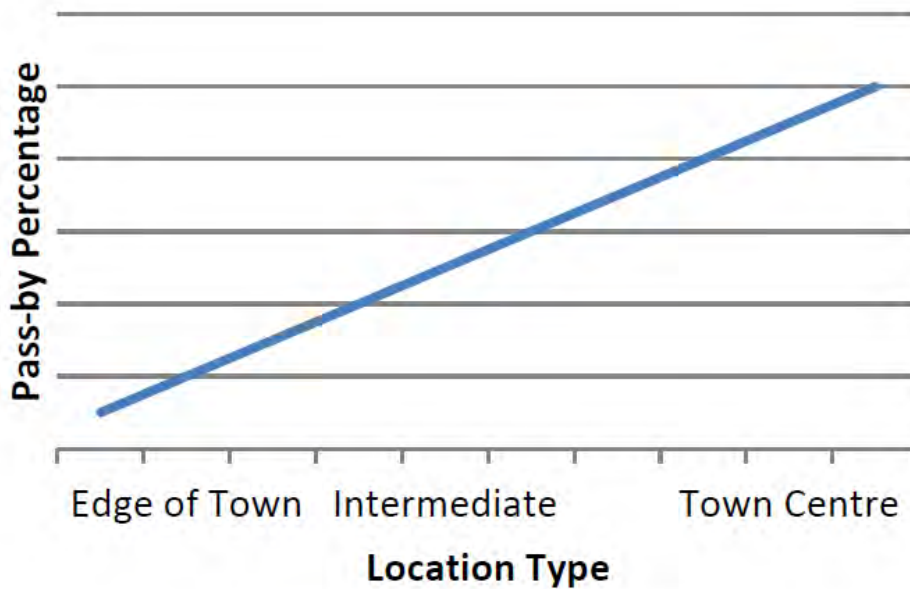

Pass-by Trips

5.39 The TRICS Research Report 14/1 indicates that a number of factors play a role in the determination of likely levels of pass-by and linked trips, these include:

- Location: “should be assigned to either town centre, intermediate location or edge of town”;
- Facilities: “should be assessed to see whether the development will have any of the facilities within the retail store such as a café, or sectors such as clothing, electricals, petrol station, pharmacy, opticians etc”;
- Gross Floor Area: “the gross floor area of the store should be noted. Two store categories have been devised based on GFA; stores with a GFA of 4,000m² or less are more likely to act as convenience stores, whilst those with a GFA higher than 4,000m² are more likely to act as comparison stores. Convenience stores are more likely to produce pass-by trips, whilst comparison stores are more likely to produce diverted trips. People are prepared to travel further to access a comparison store than a convenience store (20 minutes for a comparison store, compared to 10 minutes for convenience)”;
- Proximity to Infrastructure: “the proximity of the development to major infrastructure should be calculated. This includes, but is not limited to, railway stations and public transport interchanges; schools; large residential areas; other commercial areas; competition sites; and major office / workplace areas;” and
- “Click and Collect Services”. It is assumed that this service won’t be provided.

- 5.40 Using the criteria set out above, the site is characterised by the following:
- Location: at the edge of Bodicote village on the outskirts of Banbury; however, directly adjacent to one of the key commuter routes between Oxford and Banbury and would draw pass-by trips as a result;
 - Facilities: the proposed food store will not have any additional facilities such as a café or clothing section;
 - Gross Floor Area: at 1190sqm GFA, the site is considered more likely to act as a convenience store based on the criteria set out above;
 - Proximity to Infrastructure: the site is not situated near to any bus or rail stations which may increase the number of pass-by trips; however the site is located on the A4260 Oxford Road and is adjacent to a health club with spa and Banbury Rugby Club; and
 - Click and Collect Services: this service will not be available at the proposed food store.
- 5.41 The proposed food store is categorised as an edge of town development, therefore the percentage of pass-by trips in accordance with the graph above is restricted. However; the site is located on a principal road with potential for pass-by trips, particularly in the weekday PM peak hour as commuters will make impulse stops on their journey. Additionally, the sites proximity to infrastructure such as the health club and spa will also increase the percentage of pass-by trips.
- 5.42 The TRICS Research Report 14/1 states that stores with a GFA of 4,000m² or less are more likely to act as convenience stores, whilst those with a GFA higher than 4,000m² are more likely to act as comparison stores. The TRICS Research Report 14/1 states that convenience stores are more likely to produce pass-by trips, and the 1190sqm GFA proposed development lies within this category, increasing the potential for pass-by trips. Having assessed the pieces of academic research summarised in TRICS Research Report 14/1; the percentage of pass-by trips ranges significantly. Ghezawi et al. 91998) stated that the average percentage of pass-by trips was 72% with a range between 61% and 85%. Mouchel (2009) found that linked trips ranged between 34% to 66%, concluding that a pass-by level of 40% in this research was accepted to be a robust estimate during the weekday PM period.
- 5.43 Of the pieces of academic research cited in the TRICS Research Report 14/1, Maclver (1999) provides the most detailed and conservative estimates. Maclver (1999) summarises that for superstores located on major commuting routes in larger urban areas, the pass-by proportion may range between 25-35% depending on the levels of traffic flow, and it may be assumed that more populous urban areas will generate higher levels of pass-by trips.

Diverted Trips

- 5.44 Diverted trips are defined as already being present on the local road network, but not the road(s) from which access is taken and would divert from their existing route to access the development. Paragraph 11.10 of the TRICS Research report 14/1 states that convenience stores are more likely to produce pass-by trips, whilst comparison stores are more likely to produce diverted trips. People are prepared to travel further to access a comparison store than a convenience store (20 minutes for a comparison store, compared to 10 minutes for convenience). Stores with a GFA of 4,000m² or less are more likely to act as convenience stores, whilst those with a GFA higher than 4,000m² are more likely to act as comparison stores.

- 5.45 The number of diverted trips as a result of the proposed development is likely to be negligible. Residents in the local villages south of Banbury such as Adderbury, Deddington, King's Sutton and Milton will already be using the A4260 to commute to work, and to access the nearest major food retailers in south Banbury. As these residents are already on the road network, these vehicle movements would be included as a pass-by trip rather than a diverted trip, as they are still utilising the same section of the road network.
- 5.46 Based on the above, the percentage of diverted trips is likely to be negligible and would be offset by an increase in the percentage of pass-by trips.

Percentage of Pass-by Trips

- 5.47 Having considered the commercial and academic research summaries, based on the range of 25% to 35% cited by Maclver (1999) and site accessibility, an appropriate percentage for pass-by trips of 35% will be applied to the proposed Friday PM development trips. This considers the edge of town location, the positive relationship between pass-by trip percentage and adjacent street volumes, the potential for the site to capture passing commuter traffic, and the potential for diverted trips being classified as pass-by trips based on the location of the proposed development.
- 5.48 The potential for pass-by trips generated on a Saturday may be lower than the pass-by trip percentage on a weekday. The ATC data attached at **Appendix E** demonstrates that two-way daily traffic flows for the A4260 Oxford Road on a Friday were 22858, with Saturday flows of 17465. Proportionally, two-way daily traffic flows for a Saturday are 76.4% of Friday daily two-way traffic flows.
- 5.49 Taking into account the range of 25% to 35% cited by Maclver (1999), the application of the percentage of 76.4% to the 10% range (25% to 35%) equates to a Saturday pass-by trip of 32.6%.

New Trips

- 5.50 The number of vehicle trips to be generated by the proposed development is detailed later in this section of the report.
- 5.51 Table 7 of the Retail Impact Assessment sets out the estimated convenience goods trade draw pattern to the proposed development and the consequent impact on existing stores. The Retail Impact Assessment sets out that the majority of trips generated by the proposed development are not new trips, with Table 7 of the Retail Impact Assessment showing an estimated trade draw of £6.36m from stores within the catchment, from Sainsbury's and Morrisons in south Banbury in addition to other stores within the south Banbury area.
- 5.52 Table 4 of the Retail Impact Assessment sets out that the benchmark turnover of the proposed development in 2023 is £7.07m. The proposed trade draw to the food store is estimated to be £6.36m, as set out in Table 7 of the RIA. This equates to approximately 89.96% of the trade draw being from Sainsburys, Morrisons and smaller stores set out in the RIA.
- 5.53 Based on the above, it is calculated that of the vehicle trips to be generated by the proposed development, 89.96% will be pass-by and transferred trips, with the remaining 10.04% being new trips. The distribution of the new trips will follow the same distribution of transfer trips, set out below.

Transferred Trips

- 5.54 The TRICS Research report 14/1 does not consider transferred trips, focusing on pass-by and diverted trips only. Transferred trips will be estimated using data supplied in the Retail Impact Assessment.
- 5.55 Transfer trips are already present on the local road network, accessing similar existing sites near the proposed development and will have the potential to transfer their destination to the proposed development.
- 5.56 The Retail Impact Assessment considers the site will draw the largest part of its turnover from the Sainsbury's and Morrisons stores in south Banbury, just outside the catchment area. This will be spending by residents living in settlements in the east and west of the catchment who are currently travelling north on Upper Astrop Road and the A361 Bloxham Road for shopping in Banbury. These vehicles will route from Banbury to the proposed development.
- 5.57 Table 7 of the Retail Impact Assessment predicts a solus impact of -14.88% on sales at the Sainsbury's store in south Banbury, an -14.94% impact on sales for Morrisons, a -12.36% impact on the Spar on Oxford Road, and a -9.97% impact on the Spar at Molyneux Drive. Details of the retail impact for additional local stores are set out in the Retail Impact Assessment.
- 5.58 Table 7 of the Retail Impact Assessment states that an estimated £0.82m of the trade draw to the proposed development will be from stores within Bloxham, Adderbury, Kings Sutton, Bodicote / South Banbury and Deddington within the catchment area. A further £2.54m will be from Sainsburys, £1.91m from Morrisons, £0.45m from other stores in Banbury and an additional £0.64m from stores outside Banbury for an assessment year of 2023.
- 5.59 As set out in Tables 6 and 7 of the Retail Impact Assessment, the benchmark turnover of the proposed development in 2023 is £7.07m, of which £6.36m is anticipated to be trade draw from other food retail units within the agreed catchment area, and other stores within and surrounding Banbury.
- 5.60 The percentage of pass-by and new trips have been calculated, and the remaining trips are transfer trips. Referring to the Retail Impact Assessment, Appendix 2: Catchment Area demonstrates the eleven Lower Level Super Output Areas (LSOA) within the catchment area. To calculate the distribution of transfer trips, the estimated population of each LSOA was used to calculate the proportion of transferred vehicle movements arriving from each LSOA to the development site.
- 5.61 An allowance for pass-by, diverted and transferred trips will be incorporated into the traffic flows, set out in **Section 6**.

Summary

- 5.62 In summary, a total of 10.04% of trips associated with the proposed development will be new trips. The remaining trips will comprise of pass-by and transferred trips.
- 5.63 For a Friday PM, the percentage of pass-by trips will be 35%, 10.04% will be new trips and the remaining 54.96% will be transferred trips. For a Saturday, the percentage of pass-by trips will be 32.6%, with 10.04% of trips being new to the network and the remaining 57.36% being transferred trips. The number of vehicle movements is set out in **Appendix H**.

Distribution and Assignment of New Trips

- 5.64 The proposed development is small in size and is expected to serve a relatively confined catchment that encompasses Bodicote, the southern side of Banbury and south to just beyond Bloxham, Adderbury and Kings Sutton. The proposed development trips have been distributed across the site access junction based on an analysis of the following nine Lower Level Super Output Areas (LSOA):
- Cherwell 006D;
 - Cherwell 007A;
 - Cherwell 007C;
 - Cherwell 008A;
 - Cherwell 008B;
 - Cherwell 008C;
 - Cherwell 008D;
 - Cherwell 009A;
 - Cherwell 010A;
 - Cherwell 010B; and
 - South Northamptonshire 011A.
- 5.65 The Retail Impact Assessment details the catchment area for the proposed development. Based on the above LSOAs and the route taken by residents to access the proposed development, the distribution is set out in **Table 5.2**.

Table 5.2: Census Population Data

LSOA	Estimate Population (mid-2018)	Route to Site		A4260 North	A4260 South
		A4260 North	A4260 South		
Cherwell 006D	1,631	100%	0%	1,631	0
Cherwell 007A	1,285	100%	0%	1,285	0
Cherwell 007C	1,378	100%	0%	1,378	0
Cherwell 008A	1,678	0%	100%	0	1,678
Cherwell 008B	1,517	0%	100%	0	1,517
Cherwell 008C	3,466	100%	0%	3,466	0
Cherwell 008D	2,804	50%	50%	1,402	1,402
Cherwell 009A	1,715	50%	50%	858	858
Cherwell 010A	1,426	0%	100%	0	1,426
Cherwell 010B	1,208	0%	100%	0	1,208
South Northamptonshire 011A	2,449	0%	100%	0	2,449

5.66 Based on the information set out in **Table 5.2**, using the estimate populations, approximately 48.7% of traffic would route from the A4260 North and approximately 51.3% from the A4260 South. However, the distribution of transfer and pass-by trips would differ as food retail trips are transferred from nearby supermarkets and convenience stores.

Parking Demand

5.67 The TRICS vehicle trip rate and daily profile demonstrates that the arrivals and departures throughout the day is relatively consistent, with relatively little parking accumulation occurring if the TRICS data is analysed on an hour by hour basis. Arrivals and departures are relatively equal throughout each hour-long period.

5.68 To calculate the parking accumulation, the amount of time a customer is likely to be on site needs to be calculated. As the amount of time each customer will be on site varies on any given trip, a justification for the average value used for assessment purposes is set out below.

Time Spent on Site

5.69 To estimate the duration that users of the proposed development site may spend on site, data has been used from the Institute of Grocery Distribution (IGD), a research and training charity for the food and grocery industry. The research was conducted by the IGD for McColl's, a chain of convenience stores in the UK and some of the research findings are summarised below:

- Consumers spend an average of 16.7 hours a month food and grocery shopping, with 9.8hrs travel and 6.9hrs in stores; and
 - Convenience stores save up to 50% of time on some missions, with the average time shopping for an evening meal (including travel time) being 25 minutes for a convenience store and 46 minutes for other trips.
- 5.70 Based on the above proportions of consumers spending an average of 16.7 hours a month food and grocery shopping, with 9.8hrs travel and 6.9hrs in stores, the average length of stay in-store is 10 minutes for a convenience store trip, and 19 minutes for other trips (although this relates to all stores).
- 5.71 Based on the above proportions of consumers spending an average of 16.7 hours a month food and grocery shopping, with 9.8hrs travel and 6.9hrs in stores, the average length of stay in-store is 10 minutes for a convenience store trip, and 19 minutes for other trips (although this relates to all stores).
- 5.72 It is assumed for assessment purposes that consumers will spend an average of 15 minutes on site, as the site will serve as a convenience food store without the diverse product choice of a larger superstore such as Sainsbury's or Morrisons.

Friday PM Parking Accumulation

- 5.73 The proposed development vehicle trip generation will peak on a Friday PM, between 17:00 and 18:00. In order to assess the peak parking demand and demonstrate the site can accommodate the vehicle trips likely to be generated, vehicle trip rates derived from TRICS data in addition to an average stay of 15 minutes will be used to assess the peak parking accumulation.
- 5.74 **Table 5.3** sets out the vehicle trip rates based on TRICS 100m² GFA calculated for 1235m² GFA. There will be an estimated 117 arrivals and 120 departures during the Friday PM Peak, totalling 237 two-way vehicle movements.

Table 5.3: Friday Development Vehicular Trip Generation

Time	Arrivals	Departures	Total	Parking Accumulation
06:00-07:00	0	0	0	0
07:00-08:00	11	6	17	5
08:00-09:00	49	35	84	19
09:00-10:00	59	45	104	32
10:00-11:00	71	60	131	43
11:00-12:00	86	83	169	46
12:00-13:00	85	83	168	48
13:00-14:00	79	82	161	45
14:00-15:00	83	80	162	48
15:00-16:00	82	88	170	41
16:00-17:00	105	98	203	48
17:00-18:00	117	120	237	45
18:00-19:00	86	102	187	29
19:00-20:00	69	79	148	19
20:00-21:00	53	61	114	12
21:00-22:00	34	45	80	0
Total	1067	1067	2134	-

- 5.75 As calculated in **Table 5.3**, the peak parking accumulation which will arise from the proposed development occurs on a Friday between 16:00 and 17:00. However, this is calculated on an hour by hour basis.
- 5.76 Due to the nature of the development, the majority of vehicles that arrive to site within an hour period will leave within the same hour period; therefore, a parking accumulation needs to be calculated based on hourly development traffic and the average time a consumer is likely to be on site.
- 5.77 To calculate the potential peak parking accumulation to occur within an hour period, the following calculations have been made:
- Based on the data set out in **Table 5.3**, the peak of 117 arrivals are spread out over an hour period (17:00-18:00). This equates to approximately one vehicle arriving approximately every 31 seconds;

- A consumer will be on site for an average of fifteen minutes;
- Based on 117 vehicles arriving within an hour period at 31 second intervals and remaining on site for fifteen minutes, there will need to be 30 parking spaces for all vehicles arriving within the first 15 minute period. This is based on a vehicle arriving at 17:00, then one arriving every 31 seconds during the first fifteen minutes of the peak hour; and
- One vehicle will depart every 31 seconds after being on site for 15 minutes, equal to the arrival frequency. **Graph 5.1** demonstrates this, shown below.

Graph 5.1: Parking Accumulation During Friday Development PM Peak Hour

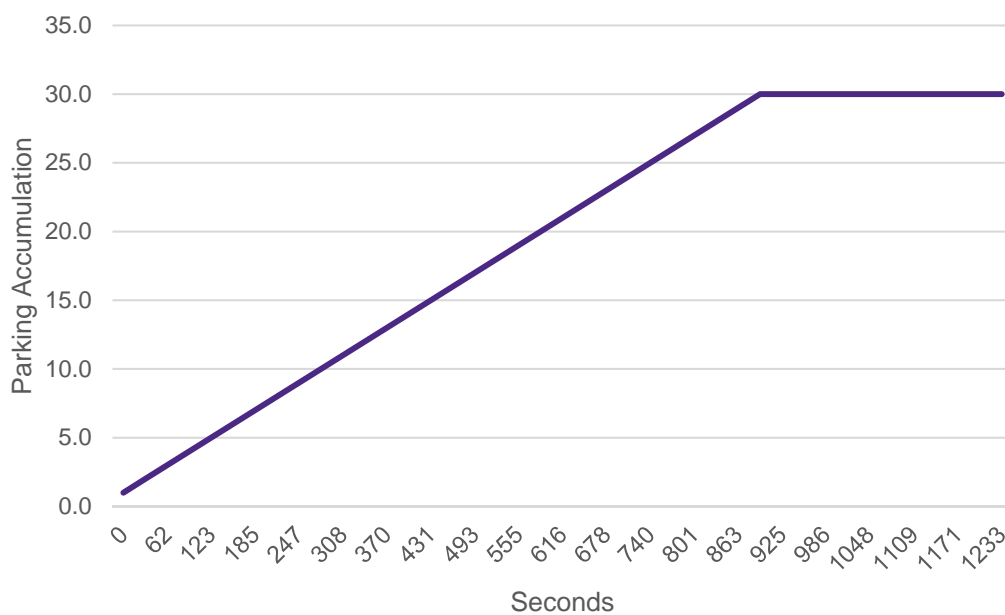

- For the above calculations, vehicles will be on site for an average of 15 minutes; therefore, there will be no vehicles from the 16:00-17:00 hour period left parked within the car park at 17:15.

5.78 The above calculations assume that there are no vehicles on site at the start of the 17:00-18:00 hour period, therefore the peak parking accumulation to occur within that hour period does not take into account other vehicles on site. To take this into account, the following assumptions have been made:

- Using the TRICS daily profile, the peak parking accumulation when calculated on an hour-by-hour basis occurs at the end of the 16:00 and 17:00 hour period, with a peak of 48 vehicles on site;
- Based on 117 vehicles arriving within an hour period at 31 second intervals and remaining on site for fifteen minutes, there will need to be 30 parking spaces;
- It is assumed that, for a worst case scenario, that the parking accumulation remains at 48 vehicles at the start of the 17:00-18:00 period; and

- Taking into account the parking accumulation of 48 vehicles at the start of the 17:00-18:00 hour and taking into account the potential parking accumulation of 30 vehicles during the PM peak hour, the peak parking accumulation would be 78 vehicles. This assumes that all vehicles on site at the end of the 16:00-17:00 time period remain on site, whereas consumers will be departing to a similar rate at which they arrive.
- 5.79 The proposed development seeks to provide a total of 86 parking spaces. The above parking accumulation calculations are undertaken for a Friday, demonstrating that the provision of parking at the site is sufficient to enable turnover of spaces.

Saturday Parking Accumulation

- 5.80 For a Saturday the peak parking accumulation will not exceed the Friday PM peak parking accumulation. As shown in **Table 5.4**, the Saturday development peak hour occurs between 16:00 and 17:00 with 73 arrivals and 64 departures, totalling 137 two-way vehicle movements.

Table 5.4: Saturday Development Vehicular Trip Generation

Time	Arrivals	Departures	Total	Parking Accumulation
06:00-07:00	0	0	0	0
07:00-08:00	10	6	16	4
08:00-09:00	32	24	56	12
09:00-10:00	54	44	98	22
10:00-11:00	59	60	119	21
11:00-12:00	67	64	131	24
12:00-13:00	62	64	126	22
13:00-14:00	70	64	134	29
14:00-15:00	67	65	131	30
15:00-16:00	69	62	131	37
16:00-17:00	73	64	137	45
17:00-18:00	51	68	119	29
18:00-19:00	49	58	108	19
19:00-20:00	33	45	78	7
20:00-21:00	14	18	33	3
21:00-22:00	7	10	16	0
Total	716	716	1431	-

- Based on 73 vehicles arriving within an hour period at 50 second intervals and remaining on site for fifteen minutes, there will need to be 18 parking spaces during the Saturday development peak hour;

- A consumer will be on site for an average of fifteen minutes; and
- One vehicle will depart every 50 seconds after being on site for 15 minutes, equal to the arrival frequency.

5.81 **Graph 5.2** demonstrates the profile of parking accumulation during the Saturday network peak hour.

Graph 5.2: Parking Accumulation During Saturday Development Peak Hour

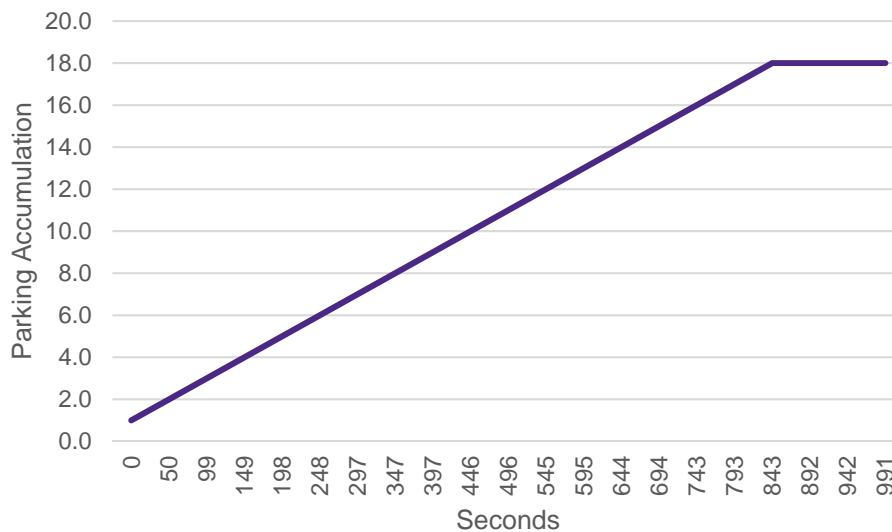

5.82 The above calculations assume that there are no vehicles on site at the start of the 16:00-17:00 hour period, therefore the peak parking accumulation to occur within that hour period does not take into account other vehicles on site. To take this into account, the following assumptions have been made:

- Using the TRICS daily profile, the parking accumulation when calculated on an hour-by-hour basis for 15:00 to 16:00 is 37 vehicles;
- Based on 73 vehicles arriving between 16:00 and 17:00 at 51 second intervals and remaining on site for fifteen minutes, there will need to be 18 parking spaces;
- It is assumed that, for an absolute worst case scenario, that the parking accumulation remains at 37 vehicles at the start of the 16:00-17:00 period; and
- Taking into account the parking accumulation of 37 vehicles at the start of the 16:00-17:00 hour and taking into account the potential parking accumulation of 18 vehicles during the Saturday development peak hour, the peak parking accumulation would be 55 vehicles. This assumes that all vehicles on site at the end of the 15:00-16:00 time period remain on site, whereas consumers will be departing to a similar rate at which they arrive.

Future Year Traffic Flows

- 5.83 An assessment year of 2024 has been selected, being five years from the year of submission.
- 5.84 During the traffic surveys undertaken as part of this assessment, most of the CALA Homes units were occupied but construction staff and contractors were still on site. As a result, the vehicle movements at the site access recorded by both manual and automatic traffic counters will not be representative of vehicle flows which will occur once the development is completed and fully occupied.
- 5.85 To establish a baseline scenario, the vehicles recorded arriving and exiting the CALA Homes development have been removed from the manual count surveys, and the same number removed from the automatic traffic counts. The predicted full residential traffic flows as calculated in its original transport assessment submitted with its planning application will be included in the baseline scenario.

Growth Rates

- 5.86 The proposed development site is located within an area of Banbury which is being developed as part of the Local Plan, with some sites under construction, some partially occupied, and some coming forward towards the end of the Plan period. In addition, there are other residential developments to the north of Banbury which model traffic flows along the A4260 Oxford Road, and they have been assumed to travel across the site access.
- 5.87 As part of the future year traffic flows, an assessment of committed developments has been undertaken based on the traffic flows set out in the developments respective Transport Assessments. Each development has undertaken a reasonable worst-case assessment in accordance with best practice.
- 5.88 Typically to establish future year peak hour traffic flows, against which the impacts of the proposed development can be assessed, observed traffic flows are growthed using the Department for Transport (DfT) software TEMPRO. However with the addition of committed and cumulative developments, this double counts and creates a scenario where we have 'worst case' on top of a 'worst case'. As a result, the model generates a scenario which would not occur.
- 5.89 Based on the above, and the number of committed and cumulative sites being added, a TEMPRO growth rate has not been applied and the traffic flows for the committed sites have been incorporated into the baseline scenario. The committed developments which have been assessed are set out below.

Committed Developments

- 5.90 A substantial proportion of the dwellings at the Bankside / Longford Park development have been built out, with almost all parcels of land being constructed on. A reserved matters application, submitted in 2015 for 215 dwellings, is the final section of Bankside which is currently under construction, with some houses for sale.
- 5.91 The traffic surveys were undertaken in September 2018, when there were no occupied dwellings on the final parcel of land at Longford Park. Therefore traffic flows associated with this section of Bankside will not have been included within the traffic surveys.

- 5.92 Based on the application for a total of 1070 dwellings at Bankside, and the reserved matters application for 215 dwellings being the final section to be constructed, it is assumed that, for assessment purposes, 80% of the proposed dwellings which are consented for the Bankside development are currently constructed and occupied.
- 5.93 A small percentage (approximately 20%) of the total dwellings to be constructed as part of Bankside are within the reserved matters application; therefore it is assumed that 20% of development traffic as set out in the Bankside transport assessment will be added to the base traffic flows.
- 5.94 As set out above, the consented 95-dwelling development (Planning Reference: 14/02156/OUT) will be included in the committed development assessment; however, the residential development has a planning condition to determine the form of access to the site from the A4260 Oxford Road.
- 5.95 Additional committed developments which have been considered as part of the assessment are set out in **Table 5.5**.

Table 5.5: Committed Developments

Planning Reference	Application Name	Development Outline	Considered on the network	Status
05/01337/OUT	Bankside	Mixed-use development including 1070 residential units and 2,200m ² of B1 office land-use.	Colin Buchanan TA (April 2005). Traffic flows shown at Weeping Cross and Farmfield Road. Assumed straight on through our Site Access.	Under Construction
11/00617/OUT	Land South of Molyneux Drive	82 residential dwellings	RPS TA April 2011 Figure 17. Assumed to continue straight on through Farmfield Road junction.	Under Construction
14/02156/OUT	Land South of Cotefield Business Park	95 dwellings	Traffic Flows taken from RPS Transport Assessment (Ref: JNY 8146-01E)	Granted
15/01326/OUT	Land west of White Post Road	The proposed development comprises the construction of up to 280 houses (up to 30% affordable)	Ashley Helme Associates TA. Traffic flows shown on A4260 Oxford Road / Weeping Cross junction, assumed to go straight through site access junction	Granted

- 5.96 Planning Application 14/02156/OUT, ‘Land South of Cotefield Business Park’, has a travel plan which sets out the following targets:

“Between the initial travel survey and first biannual travel survey:

- Achieve a 5% percent reduction in single occupancy car-driver trips to/from the development from the baseline (initial travel survey) position;
- Between the first biannual travel survey and second biannual travel survey:

- Achieve a further 5% percent reduction in single occupancy car-driver trips to/from the development from the baseline (first biannual survey) position.”
- 5.97 Based on the target reduction of single occupancy vehicle trips of approximately 10% over the Travel Plan monitoring period, the traffic flows derived from this transport assessment have been reduced by 10% to reflect the target model shift.
- 5.98 The Planning Application 11/00617/OUT, ‘Land South of Molyneux Drive’ Travel Plan sets out a target modal shift of single occupancy vehicles of 10%. Based on the target reduction of single occupancy vehicle trips of approximately 10% over the Travel Plan monitoring period, the traffic flows derived from this transport assessment have also been reduced by 10% to reflect the target model shift.
- 5.99 Planning Application 15/01326/OUT, ‘Land West of White Post Road’ states that their Travel Plan target is a maximum peak hour 2-way vehicle trip rate of 0.537 vehicles/hour/dwelling to be achieved within five years of first occupation of the development. Based on a peak hour PM trip rate of 0.658, development traffic passing through the junction has been reduced by approximately 18%.
- 5.100 The traffic flows for each of the committed developments are outlined in **Appendix H**, and the total committed development traffic is outlined for the Friday PM and Saturday peak hours.

Cumulative Developments

- 5.101 Two large cumulative developments have been incorporated into the traffic flows to assess the site access junction’s likely operation in the future assessment year of 2024, shown in **Table 5.6**.

Table 5.6: Cumulative Developments

Planning Reference	Application Name	Development Outline	Considered on the Network	Status
19/01047/OUT	Bankside 2 Land North of Health Club East of Phase 2 Longford Park Oxford Road Bodicote	Up to 850 residential dwellings, although the TA is based on a residential scheme of 900 dwellings. A new signal controlled junction with Banbury Road at the southern edge of the allocated BAN12 site.	Markides Associates TA (May 2019) Traffic flow diagrams within TA figures.	Under Consultation
14/01932/OUT	Land south of Salt Way (Wykham Farm)	Up to 1,000 dwellings together with a mixed use local centre. Including A1 retail up to 1,000 m2, financial services (A2), restaurants, pubs and takeaways (A3, A4, A5), community uses (D1); primary school and safeguarded additional primary school land; secondary school playing field land.	Environmental Statement Chapter 5: Transport and Access Jubb TA (2014). Shows traffic on A4260 - assumed straight through our network	Awaiting Decision

Bankside 2

- 5.102 Bankside 2 (original Planning Reference: 17/01408/OUT) involved an outline planning application for a residential development of up to 700 dwellings with a multi-purpose community building, green infrastructure including playing fields, and associated infrastructure with alterations to the existing access from the A4260 Oxford Road. The outline planning application for 700 units residential units on the BAN4 was submitted in June 2017 and scoping discussions took place in advance of that application. Subsequent to the discussions, further feedback was received from OCC in response to pre-application submissions to CDC in relation to the ES Scoping Submission.
- 5.103 Following submission of the outline planning application, further meetings were held with both OCC and CDC to discuss the application. Feedback given at the time was that the consideration should be given to the provision of access to the BAN4 site via BAN12. Changes to the proposals to provide a new access into the BAN4 and BAN12 sites from Banbury Road, with an extension of the redline boundary for the site into the northern section of BAN12, has led to an increase of 150 dwellings from the 2017 planning application.
- 5.104 The updated Transport Assessment (under Planning Reference 19/01047/OUT) states that in the interim, a SATURN model of the whole of Banbury was completed has now been utilised to identify the changes in traffic flows that will occur as a result of all major development in Banbury.
- 5.105 The Transport Assessment submitted under 17/01408/OUT forecast future year traffic flow utilising TEMPRO growth factors, TRICS trip rates and data from Transport Assessment of committed development in the area. For planning application 19/01047/OUT, OCC required that the Banbury SATURN model is used to obtain traffic flows forecasts. The results flows were then used in detailed junction capacity models.
- 5.106 The planning application for Bankside 2 was submitted in 2019. The SATURN modelling undertaken as part of the assessment utilised traffic flows from 2026 and 2031. However, in OCC consultation response dated 7th August 2019, OCC have stated that the Transport Assessment lacks sufficient information and evidence to provide confidence in the traffic impact assessment undertaken and there appears to be an error in the SATURN model outputs on which the assessment has been based. As a result, the county council cannot be confident in the results of the junction capacity assessments or of the conclusions made regarding the requirements for mitigation:
- “The SATURN Banbury model outputs provided in Appendix R of the TA and the traffic flow diagrams at Figures 5.1 - 5.2 and 5.5 – 5.6 show no turning movements to or from the site access arm of the Longford Park Road / Oxford Road / Weeping Cross junction in all baseline model scenarios (2026 and 2031, AM and PM). In fact, it appears from the outputs at Appendix R that the Oxford Road / Longford Park Road junction has been omitted from the Baseline scenarios entirely (it is noted that this junction is listed as ‘Junction 17’ in the ‘with development’ outputs).
- These outputs also show very few turning movements to or from the site access arm of the Longford Park Road / Bankside roundabout junction in these baseline scenarios (e.g. only 49 two-way movements in the 2031 AM peak hour). All movements that do access / egress the site at this junction are shown to arrive / depart only to / from the Bankside East arm of the junction.”
- 5.107 As the 2019 Transport Assessment for Bankside 2 does not include accurate traffic flows which are able to be used as part of an assessment, and because the planning application does not

-
- have planning consent, the traffic flows from the 2017 Transport Assessment will be factored to represent the increase from 700 dwellings to 850 dwellings.
- 5.108 The 2019 application will have assumed a 2020 start date at the time of submission, and a final design year of 2031. Based on the above, it would have been assumed that 2020 to 2031 was the construction period for this development; however, as the planning application is still under consultation and is likely to require additional assessment, it is assumed construction could instead start in 2022 and continue to 2033.
- 5.109 Based on the application of up to 850 dwellings, it is assumed that over an eleven-year construction period, an average of 78 dwellings would be constructed each year. Based on the rate of 78 dwellings constructed per year and an assessment year of 2024, approximately 156 dwellings will have been constructed and occupied between 2022 and 2024.
- 5.110 Based on the above calculations of approximately 156 of 850 dwellings being constructed and occupied, a multiplication factor of 18.4% has been applied to the factored traffic flows derived from the Bankside 2 Transport Assessment to calculate the predicted traffic flows during the assessment year of 2024.

Land South of Salt Way (Wykham Farm)

- 5.111 Land South of Salt Way (Planning reference: 14/01932/OUT) is an outline planning application for a residential development of up to 1000 dwellings, summarised in **Table 5.6**. The application was submitted in November 2014 and a design year of 2027 was identified as an appropriate timeline for the build out of the site.
- 5.112 A 2014 application will have assumed a 2015 start date at the time of submission. Based on the above, it would have been assumed that 2015 to 2027 was the construction period for this development, occurring over twelve years.
- 5.113 The planning application, as of November 2019, is in the late stages of its application, at the determining period to allow for the final drafting of the s106 agreement. Based on this, it can be assumed that construction could commence in 2021, maintaining the 12-year construction period and continuing to 2033.
- 5.114 Based on the application of up to 1000 dwellings, it is assumed that over a twelve-year construction period, an average of 84 dwellings would be constructed each year. Based on the rate of 84 dwellings constructed per year and an assessment year of 2024, approximately 252 dwellings will have been constructed and occupied between 2021 and 2024.
- 5.115 Based on the above, a multiplication factor of 25.2% has been applied to the traffic flows derived from the Land South of Salt Way to calculate the predicted traffic flows during the assessment year of 2024.
- 5.116 Oxfordshire County Council's Transport for New Developments: Transport Assessments and Travel Plans (2014) states that Travel Plan targets must be made in agreement with Oxfordshire County Council. Whilst both cumulative sites have not taken into account a reduction in single occupancy vehicle trips as a result of a travel plan implementation, the traffic flows derived from this transport assessment have been reduced by 10% to reflect a target model shift.

Factoring Residential Traffic Flows

- 5.117 The cumulative and committed residential developments assess a weekday AM and PM peak hour within their transport assessments, in line with typical residential peak hours. As a result, they do not assess their development traffic flows for a Saturday peak period, which is the typical retail vehicle trip generation peak.
- 5.118 In order to enable an analysis of the impact of the committed developments through the site access / A4260 Oxford Road junction during the Saturday peak, a vehicle trip rate was obtained by an analysis of the Trip Rate Information Computer System (TRICS Version 7.6.3) database for similar sites.
- 5.119 As there are few residential sites in TRICS which have Saturday surveys, one trip rate has been obtained and applied to all cumulative and committed developments in the absence of Saturday traffic flows. The TRICS trip rates are set out in **Table 5.7**.
- 5.120 The Friday PM traffic flows from each committed and cumulative development that assessed traffic flows on the A4260 Oxford Road were factored using the Saturday vehicle trip rate and the Friday vehicle trip rate. All factored Saturday cumulative and committed development traffic flows are set out at **Appendix H**. The application of a factor rather than a Saturday trip rate retains the fabric and selection process methodology of the trip rates utilised for each Transport Assessment.

Table 5.7: TRICS Saturday Peak Trip Rates

	Arrivals	Departures	Two-way
Vehicle Trip Rate (12:00-13:00)	0.134	0.235	0.369
Total Person Trip Rate (12:00-13:00)	0.202	0.412	0.614

Table 5.8: TRICS Weekday PM Peak Trip Rates

	Arrivals	Departures	Two-way
Vehicle Trip Rate (17:00-18:00)	0.358	0.152	0.51
Total Person Trip Rate (17:00-18:00)	0.573	0.264	0.837

- 5.121 One site assessed as part of the committed assessment, Bankside, has a mix of residential units and office land use; however, the Transport Assessment states that of the 80 northbound trips associated with the development during the weekday PM peak hour, only one is an employment trip. Of the 63 southbound vehicle movements during the weekday PM peak hour, four are employment trips. This is set out in **Appendix H**.

- 5.122 As the percentage of employment trips is low relative to the percentage of residential trips, the Saturday factor was applied to the Friday traffic flows without discounting the office vehicle movements for the Bankside development.
- 5.123 The above numbers were set out in the Transport Assessment for the Bankside 2 planning application (original Planning Reference: 17/01408/OUT). As the updated Bankside 2 Transport Assessment, the SATURN model was used to obtain traffic flows forecasts. The results flows were then used in detailed junction capacity models. As a result, the traffic flows for their committed and cumulative analysis are not set out within the Transport Assessment.
- 5.124 For the 'Land South of Salt Way' committed development, there is a mixture of residential, A1 retail and a range of other land uses within the traffic flows. However; as it is not possible to ascertain the number of vehicles attributed to each land use and discount vehicle trips that will not occur on a Saturday (i.e. education), the Saturday factor was applied to the Friday traffic flows without discounting vehicle movements attributed to other land uses within this development.
- 5.125 All factored Saturday cumulative and committed development traffic flows are set out at **Appendix H**.

Baseline Scenario

- 5.126 The committed developments have been added to the 2018 observed traffic flows for both the Friday PM and Saturday peak hours to create both a 2024 baseline scenario. The resultant 2024 Baseline traffic flows for the Friday and Saturday peak hour peaks are outlined in **Appendix H** respectively.
- 5.127 The 2024 baseline plus development traffic flows are shown for the Friday PM and Saturday peak hour in **Appendix H** respectively. The baseline plus development, and baseline plus committed plus development scenarios, assess the impact of the existing consented development in partnership with the cumulative and committed development traffic on the existing road network.

Parking Capacity Analysis

- 5.128 The peak parking accumulation for all units across Cotefield Business Park (excluding Cotefield Nurseries) was 83 vehicles between 12:00 and 13:00 on Friday 28 September 2018, and 81 vehicles between 10:30 and 11:30 on Saturday 29 September 2018.
- 5.129 An assessment of parking capacity will be based on the peak parking accumulation of 83 vehicles at Cotefield Business Park. Of the 83 vehicles, 27 were parked within Zone 2.
- 5.130 For a worst case assessment of the parking availability, it is assumed that all vehicles parked in Zone 2 are visitors of the auction house and would need to be accommodated elsewhere on the site should the site be developed. However, these vehicles comprise both visitors to the auction house and contractors for the CALA homes development; the contractors will not be on site once the proposed development is constructed.
- 5.131 The location of the service yard to the south of the building will result in the loss of three parking zones currently used by the units at Cotefield Business Park. Referring to Appendices C and A, the location of the loading bay and swept path of an HGV reversing into the site will remove

parking available at Zones 3, 4, 5 and approximately 50% of spaces from Zone 10. This is set out in **Table 5.9**, which sets out that a total of 10 vehicles parked in Zones 3, 4 and 5 would also need to be accommodated within alternative parking zones.

Table 5.9: Parking Capacity and Accumulation

Zone	Assumptions	Useable Parking Area	Estimated Parking Spaces	Spare Capacity After Development	Peak Parking Accumulation (Friday 13:00)
1	6m between parking rows Parking bays 2.5mx5m	3 rows 30x5m, 6m apart =3x12 parking spaces	36	-	4
2	6m between parking rows Parking bays 2.5mx5m	3 rows 30x5m =3x12 parking spaces	36	-	27
3	2.5x5m bays	1 row 10x5m	4	4	2
4	2.5x5m bays	1 row 12.5x5m	5	5	2
5	2.5x5m bays	1 row 20x5m	8	8	6
6	2.5x5m bays	1 row 15x5m	6	6	5
7	2.5x5m bays	1 row 17.5x5m	7	7	4
8	2.5x5m bays	1 row 10x5m	4	4	3
9	2.5x5m bays	1 row 15x5m 1 row 10x5m	10	10	9
10	2.5x5m bays	1 row 30x5m	12	12	6
11	2.5x5m bays parallel bays 2.5x6m	1 row 30x5m (12) 1 row 15x5m (6) 1 row parallel bays 18mx2.5m (3)	21	21	2
12		Excluded			
13		Excluded - can only be reached through the auction house			
14	2.5x5m bays	1 row 22.5x5m (9) 1 row 12.5x5m (4)	13	13	11
Total			162	90	81

5.132 **Table 5.9** demonstrates that the spare parking capacity of additional parking spaces at Cotefield Business Park would be able to accommodate the 31 vehicles located in Zones 1 and 2 of the parking beat survey once the site is developed. No areas are reserved for parking for other units, and all units share parking within the site.

6 IMPACTS AND OPERATIONAL ASSESSMENT

- 6.1 The potential increase in traffic flows generated by the proposed development has been assessed for the future year of 2024, being five years after the year of submission.
- 6.2 Operational assessments of the site access junction with the A4260 Oxford Road have been undertaken using the Transport Research Laboratory (TRL) modelling software Junctions 9 PICADY.

Development Traffic Impact

- 6.3 The increases in traffic flows on the surrounding network have been calculated to establish the potential impact of the proposed development on the local highway network. Based on the survey data and the trip generation shown within Section 5, the following scenarios have been modelled for both a Friday PM Network Peak (16:00-17:00) and Saturday network peak (12:00-13:00) at **Appendix H**, and modelled using Junctions 9 for the following scenarios:

- 2018 Observed;
- 2024 Baseline;
- 2024 Baseline + Development;
- 2024 Baseline + Cumulative Development; and
- 2024 Baseline + Cumulative Development + Development traffic flows.

Junction Capacity Assessments

- 6.4 As set out above, the operational and capacity assessments of the junctions have been undertaken using the TRL software Junction 9 – PICADY. The junction geometries for the site access are based on OS mapping.
- 6.5 PICADY provides two main measures of junction capacity and operation, namely traffic demand relative to capacity (RFC) and queue length. These measurements are discussed briefly below.

Rate of Flow to Capacity (RFC)

- 6.6 Within PICADY the RFC (ratio of flow to capacity) provides the primary measure of the capacity of a junction and is reported for each priority controlled entry arm. When RFC exceeds 1.0 the arm is considered to be operating over capacity, and queuing will occur.

Queue Length

- 6.7 Queue length (Q) provides an indication of how the overall junction performance may affect adjacent junctions on the highway network.

Site Access / A4260 Priority junction

- 6.8 The existing Cotefield Business Park access will be used to serve the proposed food store development. A junction capacity assessment using PICADY has been undertaken for this junction.

6.9 The results of the analysis of the “2018 Observed” traffic at the site access / A4260 Priority junction are shown in **Table 6.1** while the PICADY output can be found in **Appendix I**.

Table 6.1: Site Access Road / Oxford Road Junction: 2018 Observed

Link	Friday PM Peak		Saturday Peak	
	RFC	Queue	RFC	Queue
Site Access left to A4260 Oxford Road (N)	0.14	0.2	0.09	0.1
Site Access right to A4260 Oxford Road (S)	0.24	0.3	0.10	0.1
A4260 Oxford Road (N) Right Turn	0.07	0.1	0.09	0.1

6.10 **Table 6.1** summarises the results of the 2018 observed traffic flows. The junction operates within capacity, with a max RFC of 0.24 occurring on the site access during the Friday peak hour with no associated queue.

6.11 The committed developments outlined in Section 6 have been added to the 2018 base traffic flows to form the 2024 baseline. The results of the operational assessments are outlined in **Table 6.2** below.

Table 6.2: Site Access Road / Oxford Road Junction: 2024 Baseline

Link	Friday PM Peak		Saturday Peak	
	RFC	Queue	RFC	Queue
Site Access left to A4260 Oxford Road (N)	0.18	0.2	0.13	0.1
Site Access right to A4260 Oxford Road (S)	0.31	0.4	0.15	0.2
A4260 Oxford Road (N) Right Turn	0.13	0.1	0.10	0.1

6.12 **Table 6.2** shows that the site access junction currently operates within capacity with a maximum RFC in the 2024 Interim Baseline Friday PM peak of 0.28 on the site access right turn movement with no associated queue. The junction is anticipated to continue operating within capacity in the 2024 Baseline scenario with a maximum RFC in the 2024 Friday PM peak of 0.31 on the site access right turn movement.

6.13 **Table 6.3** summarises the results of the 2024 baseline traffic flows with the addition of the proposed development traffic.

Table 6.3: Site Access Road / Oxford Road Junction: 2024 Baseline ‘with Development’ Results

Link	Friday PM Peak		Saturday Peak	
	RFC	Queue	RFC	Queue
Site Access left to A4260 Oxford Road (N)	0.42	0.7	0.21	0.3
Site Access right to A4260 Oxford Road (S)	0.73	2.2	0.32	0.5
A4260 Oxford Road (N) Right Turn	0.27	0.4	0.17	0.2

- 6.14 **Table 6.3** demonstrates that with the addition of development traffic, the site access junction is operating within capacity in the Friday PM peak period, with a maximum RFC of 0.73 on the site access turning left onto the A4260 Oxford Road and queue of 2 vehicles.
- 6.15 **Table 6.3** also shows that with the addition of the development traffic the site access junction is anticipated to continue operating within capacity in the Saturday Peak 2024 baseline + development scenarios with a maximum RFC of 0.32 on the site access right turn movement with no associated queue.
- 6.16 The cumulative developments outlined in Section 6 have been added to the 2024 baseline traffic flows and the results of the operational assessments are outlined in **Table 6.4**.

Table 6.4: Site Access Road / Oxford Road Junction: 2024 Baseline ‘with Cumulative’ Results

Link	Friday PM Peak		Saturday Peak	
	RFC	Queue	RFC	Queue
Site Access left to A4260 Oxford Road (N)	0.18	0.2	0.13	0.2
Site Access right to A4260 Oxford Road (S)	0.34	0.5	0.15	0.2
A4260 Oxford Road (N) Right Turn	0.13	0.1	0.10	0.1

- 6.17 **Table 6.4** shows that with the addition of cumulative development traffic the site access junction is anticipated to operate in the 2024 baseline + committed scenarios with a maximum RFC of 0.34 on the site access right turn movement in the Friday PM peak with no associated queue.
- 6.18 **Table 6.4** also shows that with the addition of cumulative development traffic, the site access junction is anticipated to continue operating within capacity in the Saturday Peak with a maximum RFC of 0.15 on the site access right turn movement with no associated queue.

6.19 The proposed development traffic flows have been added to the 2024 baseline + cumulative development scenarios and the results of the operational assessments are outlined in **Table 6.5** below.

Table 6.5: Site Access Road / Oxford Road Junction: 2024 Baseline ‘with Cumulative and Development’ Results

Link	Friday PM Peak		Saturday Peak	
	RFC	Queue	RFC	Queue
Site Access left to A4260 Oxford Road (N)	0.52	1.0	0.21	0.3
Site Access right to A4260 Oxford Road (S)	0.80	2.9	0.33	0.5
A4260 Oxford Road (N) Right Turn	0.27	0.4	0.17	0.2

6.20 **Table 6.5** demonstrates that in the 2024 baseline + committed + development PM peak the addition of the committed development is anticipated to result in the junction operating within capacity with a maximum RFC of 0.80 on the site access right turn movement.

6.21 In the 2024 baseline + committed + development scenario the junction is anticipated to operate within capacity in the Saturday peak with a maximum RFC of 0.33 on the site access right turn movement.

Summary

6.22 The junction capacity assessments demonstrate that the proposed development will increase traffic flows on the local road network, however the site access junction will operate within capacity with the addition of development traffic. With the addition of the committed development traffic flows the site access junction in the 2024 baseline + development + committed PM peak hour scenario will operate within capacity.

6.23 With regard to highway safety, **Section 2** demonstrated that there were no road safety issues. The proposal will generate the same types and classifications of vehicles that are already on the highway network, and there is nothing to suggest that the injury accident rate will be altered. It is considered that the proposals will not create an unacceptable impact on road safety.

6.24 It is considered that the development proposal would not have a detrimental impact on the operation of the local highway or transport networks, nor would it have an unacceptable impact on highway safety. The proposed development would not have a severe residual impact, and it is thus in accordance with the requirements of the NPPF.

7 SUMMARY AND CONCLUSIONS

- 7.1 This Transport Assessment (TA) has been prepared by RPS to support a planning application for a 1190sqm (gross) food store at Cotefield Business Park, Bodicote with associated access, parking, delivery area and landscaping.
- 7.2 This TA considers the highway and transport matters associated with the proposed development and has been produced in accordance with National Planning Policy Framework, and Planning Policy Guidance on Travel Plans, Transport Assessments and statements in decision-taking.
- 7.3 This TA has been prepared following the receipt of comments from the Local Highway Authority (LHA) Oxfordshire County Council (OCC), a copy of which is attached at **Appendix B**. The TA has been prepared in accordance with these comments.
- 7.4 The development proposals are consistent with transport planning policies at a national and local level.
- 7.5 An analysis of the Personal Injury Accident data of the A4260 within the vicinity of the site access shows that there are no road safety issues within the vicinity of the site that would be exacerbated by the proposed development.
- 7.6 Trips have been generated for the proposed development site using TRICS and have considered the level of new trips on the network, plus those that would already be on the network and travel to and from the site.
- 7.7 An operational assessment has been undertaken of the site access road / A4260 Oxford Road junction. This has demonstrated that in 2018 and 2024 the junctions will operate satisfactorily in the base scenarios and the inclusion of proposed development traffic will not adversely affect this.
- 7.8 It is considered that the development proposal would not have a detrimental impact on the operation of the local highway or transport networks or highway safety and would not have a severe residual impact in accordance with the requirements of the NPPF.

Figures

Figure 1 – Site Location Plan

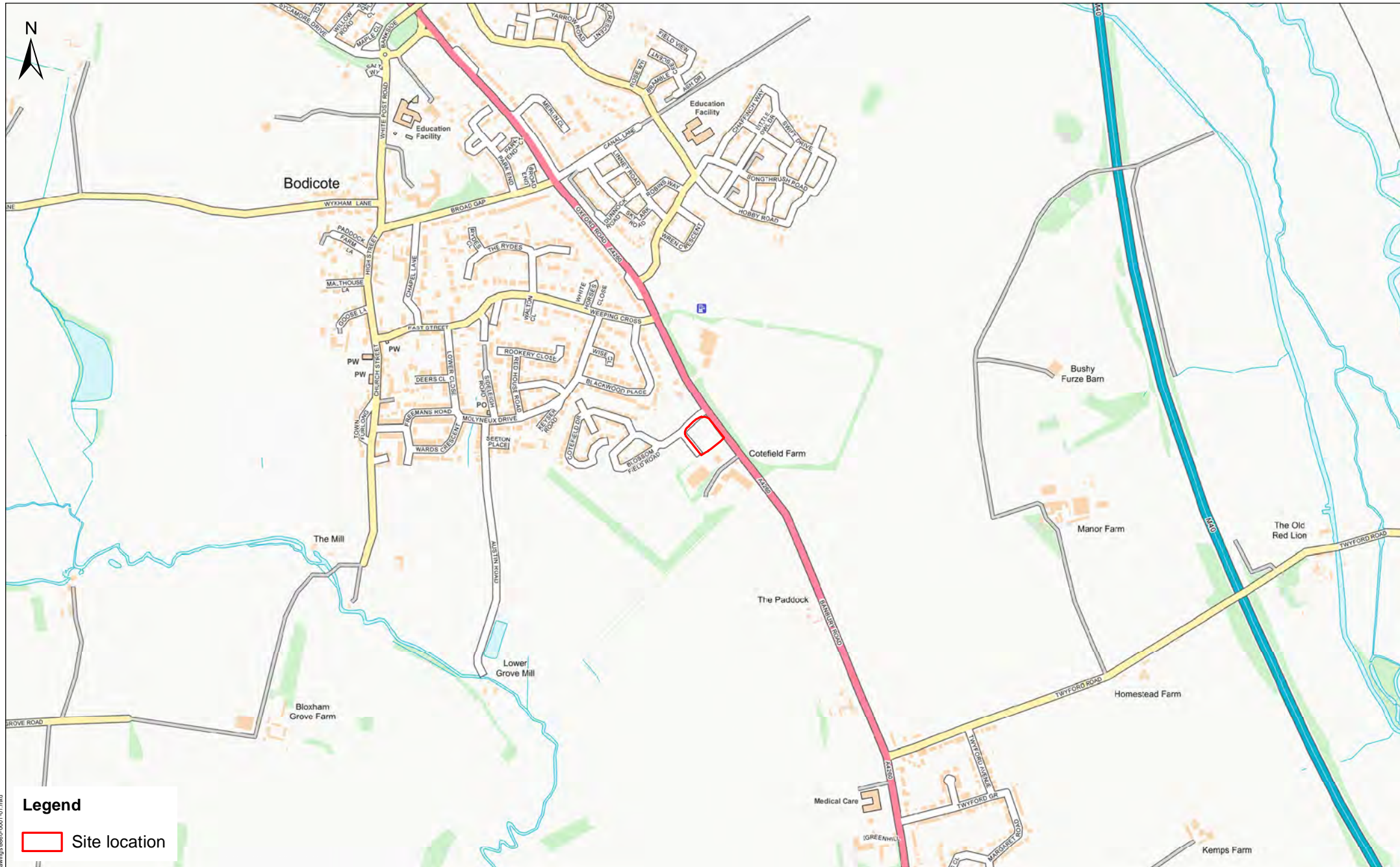

Legend

Site location



Date: Dec 2018 Scale: 1:12,000 Rev:
 Drwg. No: JNY9860 Drawn: CR Checked: JG

Project:
COTEFIELD FARM RETAIL
 Title:
SITE LOCATION PLAN

Figure No:
 1

Figure 2 – Public Transport Provision

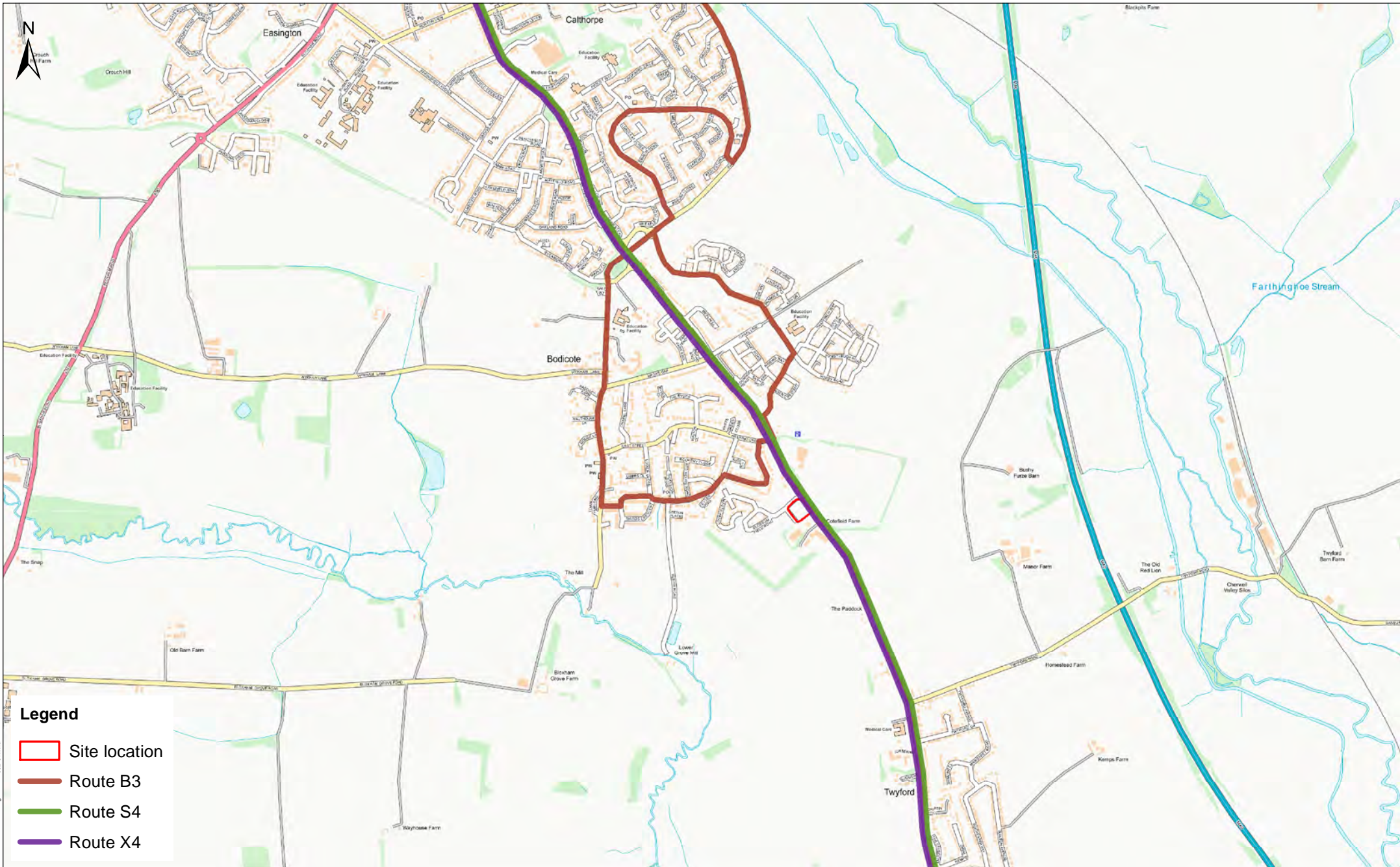

- Legend**
- Site location
 - Route B3
 - Route S4
 - Route X4

Path: \\saur-mplb-02\projects\TRANSPORT\JNY9860\Final\Drawing\860-0002_01.mxd



Date: Dec 2018 Scale: 1:20,000 Rev:
 Drwg. No: JNY9860 Drawn: CR Checked: JG

Project: COTFIELD FARM RETAIL
 Title: BUS FACILITIES

Figure No: 2

Appendices

Appendix A – Proposed Site Plan

DO NOT SCALE FROM THIS DRAWING - Figured dimensions only to be used for setting out.
Any dimensional discrepancies found on site are to be brought to the attention of the architect or
contract administrator immediately, IF IN DOUBT ASK!

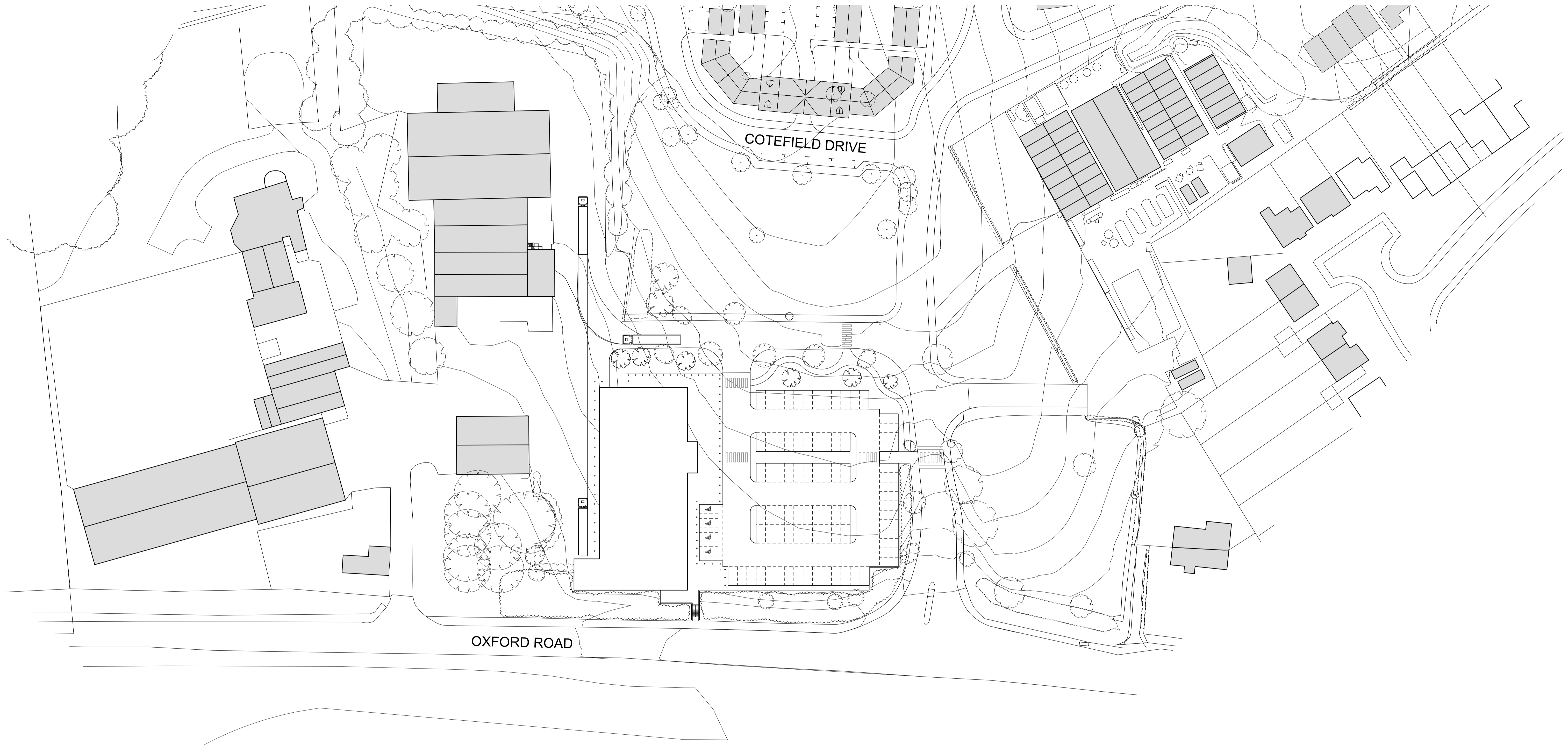

	Project: Cotefield Farm	Job No: 39042
	Drawing Title: Proposed Site Plan	Drawing No: 02 rev. A
1 Water End Barns Water End Eversholt MK17 9EA t 01525 309 400 hello@madebyprosper.com madebyprosper.com	Date: Jan 2019	Drawn: KD Checked: BM
	Client: Will Bratt	Scale: 1:500@A1

Appendix B – Cherwell District Council Comments

CHERWELL DISTRICT COUNCIL

Pre-Application Report

Pre-application Reference No:	18/00060/PREAPP
Proposal:	The proposed development will comprise a 732sqm (gross) convenience store with associated access, parking, delivery area and landscaping. This is a follow-up request relating to an updated Retail Impact Assessment.
Site Address:	Land West Of Cotefield Business Park Oxford Road, Bodicote

TECHNICAL ASSESSMENT

Consultations Undertaken:

- **Business Support Unit:** No comment received
- **Economic Development:** No comment received
- **Planning Policy:** No comment received

(Please note, should comments be received from any of the above consultees post preparation of this report, these will be forwarded under separate cover as soon as available).

Flood Risk: The site is within Flood Zone 1 which is the zone of lowest flood risk. The Environment Agency has produced advice for applicants and agents about assessing flood risk in the planning process, and this can be viewed online at: <https://www.gov.uk/flood-risk-assessment-for-planning-applications>. You should have regard to this advice when preparing your application.

The Environment Agency also offers a pre-application service, details about which are available online at: <https://www.gov.uk/government/publications/planning-advice-environment-agency-standard-terms-and-conditions>

EIA Screening Opinion Required? No

Committee or Delegated Matter?

The matter is likely to be delegated unless it is requested to be brought to Committee by a Member of the Council.

Relevant Planning History: Please refer to our response to your previous pre-application enquiry (our ref. 17/00017/PREAPP).

You should be aware of the following matters/issues/designations:

As noted in our previous response, the site is within a Minerals Consultation Area, and there are a number of protected trees (Tree Preservation Order 12/1994) at the adjacent site Cotefield Farm to the south-east.

Policy Context: Please refer to our response to your previous pre-application enquiry (our ref: 17/00017/PREAPP).

PROFESSIONAL ASSESSMENT BY CASE OFFICER

This pre-application enquiry comes following a previous response given in relation to the proposed development of a convenience store with associated access, parking, delivery area and landscaping at the site. Specifically our comment was:

“I would question whether there is a need for a retail unit of the scale proposed in this location, given the proximity to existing retail outlets and also new development being brought forward within Longford Park. Should proposals be progressed any such need would need to be fully justified within supporting documentation, and in accordance with the provisions of Policy SLE 2 of the CLP 2031 any proposed retail development would need to be supported by a retail sequential test and, given the site’s rural location and scale of proposed floorspace, a retail impact assessment; including, but not limited to, potential impacts on the existing facilities within Bodicote and new development within Longford Park. Without demonstrating such a need it is unlikely that the principle of development would be supported in this location.”

Your pre-application enquiry seeks comment on the submitted Retail Impact Assessment. As such, comments within this report will be confined to this aspect only and reference should be made to the previous response 17/00017/PREAPP for the Council’s opinion on all other aspects of the proposed development.

As previously advised in the original pre-application response, the proposed site is not an allocated site, being situated on an edge of village location, and the principle of development will need to be considered with regard to policies PSD1, SLE1 and SLE2.

The submitted Retail Impact Assessment (‘RIA’) does not adequately assess the impact of the proposal on smaller local convenience stores/smaller retail outlets in surrounding villages (as identified as being within the catchment area at Appendix 5 of the RIA), only larger supermarkets. The retail impact assessment needs to take into account the impact on viability of these smaller stores within villages, which have been effectively disregarded due to their alternative retail offering.

The Council would need to understand the potential trade diversion away from these smaller retail outlets, to ensure that the proposals would not have a significant adverse impact on the future sustainability of these businesses and settlements within which they are set.

Due regard would also need to be had within any subsequent updated RIA for retail offering that is to be brought forward as part of the Castle Quay development which has outline consent 16/02366/OUT, with detailed application 17/00284/REM currently with the Council.

No consideration has been given as to whether this proposed location is the most suitable; a sequential test needs to be undertaken in this respect. The sequential test needs to identify why other sites have been discounted and also needs to demonstrate why Longford Park (05/01337/OUT) (Banbury 4) and South of Salt Way (14/01932/OUT) (Banbury 17) are unsuitable locations. The local centres within these new developments are key to community cohesion and to the overall success of these new developments. There is a risk that the vitality and viability of these local centres could be harmed.

Please note that the Council would seek its own independent advice from an external Retail Consultant in respect of a RIA submitted in support of any subsequent planning application.

I cannot make any further comment on the acceptability or otherwise on the principle of development until the above matters have been satisfactorily addressed.

Notwithstanding the above, should you wish to make an application, in addition to national application requirements, you should also include in your submission the following additional plans/information:

- Planning Statement (to include retail sequential test)
- Retail Impact Assessment
- Transport
- Energy Statement
- Renewable Energy Feasibility Assessment;
- Sustainable Drainage Strategy; including floodrisk and ground condition assessments;
- Proposed materials – make, type, colour etc
- A BS 5837 tree survey with root protection area
- Hard and soft landscaping proposals (to include hedge and shrub planting, sizes, species, positions, area of grass seeded/turfed; trees/hedges to be retained and proposed boundary treatments)
- Proposed refuse storage areas and bin collection points

Based on the current fee regulations, the fee for your application will be £462.00 per every 75m² of floor space (G.E.A.) (or part thereof) if a full planning application or £462.00 per 0.1ha of site area if outline application only.

Date of Report: 16/04/2018

Case Officer: Bob Neville

DISCLAIMER

The above advice represents the professional views of Council Officers and although given in good faith, it cannot prejudice any decision with the Council, as Local Planning Authority, may make at either Planning Committee or delegated officer level.

Appendix C – Parking Beat Survey Data



**8643 / BODICOTE BUSINESS PARK
SEPTEMBER 2018
PARKING BEAT SURVEY**

ZONE: 1

DATE: 28/09/2018

LOCATION: Bodicote Business Park

DAY: Friday

TIME	ZONE 1						TOTAL
	CAR	LGV	OGV1	OGV2	PSV	MCL	
07:00	0	0	0	0	0	0	0
07:30	0	0	0	0	0	0	0
08:00	0	0	0	0	0	0	0
08:30	0	0	0	0	0	0	0
09:00	0	0	0	0	0	0	0
09:30	0	0	0	0	0	0	0
10:00	0	0	0	0	0	0	0
10:30	3	2	0	0	0	0	5
11:00	3	1	0	0	0	0	4
11:30	2	2	0	0	0	0	4
12:00	3	1	0	0	0	0	4
12:30	2	1	0	0	0	0	3
13:00	2	2	0	0	0	0	4
13:30	3	2	0	0	0	0	5
14:00	3	2	0	0	0	0	5
14:30	3	2	0	0	0	0	5
15:00	3	1	0	0	0	0	4
15:30	3	0	0	0	0	0	3
16:00	1	2	0	0	0	0	3
16:30	0	0	0	0	0	0	0
17:00	0	0	1	0	0	0	1
17:30	0	0	1	0	0	0	1
18:00	0	0	1	0	0	0	1
18:30	0	0	1	0	0	0	1
19:00	0	0	1	0	0	0	1



**8643 / BODICOTE BUSINESS PARK
 SEPTEMBER 2018
 PARKING BEAT SURVEY**

ZONE: 2

DATE: 28/09/2018

LOCATION: Bodicote Business Park

DAY: Friday

TIME	ZONE 2						TOTAL
	CAR	LGV	OGV1	OGV2	PSV	MCL	
07:00	0	0	0	0	0	0	0
07:30	0	0	0	0	0	0	0
08:00	0	0	0	0	0	0	0
08:30	0	0	0	0	0	0	0
09:00	0	0	0	0	0	0	0
09:30	0	0	0	0	0	0	0
10:00	0	0	0	0	0	0	0
10:30	17	1	1	0	0	0	19
11:00	17	2	1	0	0	0	20
11:30	19	1	1	0	0	0	21
12:00	20	2	1	0	0	0	23
12:30	20	3	1	0	0	0	24
13:00	22	4	1	0	0	0	27
13:30	24	3	1	0	0	0	28
14:00	25	2	1	0	0	0	28
14:30	25	2	1	0	0	0	28
15:00	20	2	1	0	0	0	23
15:30	19	2	1	0	0	0	22
16:00	18	2	1	0	0	0	21
16:30	11	1	0	0	0	0	12
17:00	10	1	0	0	0	0	11
17:30	2	0	0	0	0	0	2
18:00	1	0	0	0	0	0	1
18:30	0	0	0	0	0	0	0
19:00	0	0	0	0	0	0	0



ZONE: 3

DATE: 28/09/2018

LOCATION: Bodicote Business Park

DAY: Friday

TIME	ZONE 3						TOTAL
	CAR	LGV	OGV1	OGV2	PSV	MCL	
07:00	0	0	0	0	0	0	0
07:30	0	0	0	0	0	0	0
08:00	0	0	0	0	0	0	0
08:30	0	0	0	0	0	0	0
09:00	0	0	0	0	0	0	0
09:30	0	0	0	0	0	0	0
10:00	0	0	0	0	0	0	0
10:30	2	0	0	0	0	0	2
11:00	3	0	0	0	0	0	3
11:30	2	0	0	0	0	0	2
12:00	2	0	0	0	0	0	2
12:30	2	0	0	0	0	0	2
13:00	2	0	0	0	0	0	2
13:30	2	0	0	0	0	0	2
14:00	2	0	0	0	0	0	2
14:30	3	0	0	0	0	0	3
15:00	3	0	0	0	0	0	3
15:30	1	1	0	0	0	0	2
16:00	1	1	0	0	0	0	2
16:30	0	0	0	0	0	0	0
17:00	0	0	0	0	0	0	0
17:30	0	0	0	0	0	0	0
18:00	0	0	0	0	0	0	0
18:30	0	0	0	0	0	0	0
19:00	0	0	0	0	0	0	0



**8643 / BODICOTE BUSINESS PARK
 SEPTEMBER 2018
 PARKING BEAT SURVEY**

ZONE: 4

DATE: 28/09/2018

LOCATION: Bodicote Business Park

DAY: Friday

TIME	ZONE 4						TOTAL
	CAR	LGV	OGV1	OGV2	PSV	MCL	
07:00	0	0	0	0	0	0	0
07:30	0	0	0	0	0	0	0
08:00	0	0	0	0	0	0	0
08:30	0	0	0	0	0	0	0
09:00	0	0	0	0	0	0	0
09:30	0	0	0	0	0	0	0
10:00	0	0	0	0	0	0	0
10:30	2	0	0	0	0	0	2
11:00	2	0	0	0	0	0	2
11:30	2	0	0	0	0	0	2
12:00	1	0	0	0	0	0	1
12:30	2	0	0	0	0	0	2
13:00	2	0	0	0	0	0	2
13:30	2	0	0	0	0	0	2
14:00	2	0	0	0	0	0	2
14:30	2	0	0	0	0	0	2
15:00	2	0	0	0	0	0	2
15:30	4	0	0	0	0	0	4
16:00	4	0	0	0	0	0	4
16:30	2	0	0	0	0	0	2
17:00	2	0	0	0	0	0	2
17:30	2	0	0	0	0	0	2
18:00	1	0	0	0	0	0	1
18:30	1	0	0	0	0	0	1
19:00	1	0	0	0	0	0	1



**8643 / BODICOTE BUSINESS PARK
SEPTEMBER 2018
PARKING BEAT SURVEY**

ZONE: 5

DATE: 28/09/2018

LOCATION: Bodicote Business Park

DAY: Friday

TIME	ZONE 5						TOTAL
	CAR	LGV	OGV1	OGV2	PSV	MCL	
07:00	0	0	0	0	0	0	0
07:30	0	0	0	0	0	0	0
08:00	0	0	0	0	0	0	0
08:30	0	0	0	0	0	0	0
09:00	0	0	0	0	0	0	0
09:30	0	0	0	0	0	0	0
10:00	0	0	0	0	0	0	0
10:30	1	1	0	0	0	0	2
11:00	2	1	0	0	0	0	3
11:30	3	0	0	0	0	0	3
12:00	4	0	0	0	0	0	4
12:30	4	1	0	0	0	0	5
13:00	5	1	0	0	0	0	6
13:30	4	1	0	0	0	0	5
14:00	4	1	0	0	0	0	5
14:30	5	0	0	0	0	0	5
15:00	5	0	0	0	0	0	5
15:30	4	0	0	0	0	0	4
16:00	4	0	0	0	0	0	4
16:30	2	0	0	0	0	0	2
17:00	2	0	0	0	0	0	2
17:30	0	0	0	0	0	0	0
18:00	0	0	0	0	0	0	0
18:30	0	0	0	0	0	0	0
19:00	0	0	0	0	0	0	0

ZONE: 6

DATE: 28/09/2018

LOCATION: Bodicote Business Park

DAY: Friday

TIME	ZONE 6						TOTAL
	CAR	LGV	OGV1	OGV2	PSV	MCL	
07:00	0	0	0	0	0	0	0
07:30	0	0	0	0	0	0	0
08:00	0	0	0	0	0	0	0
08:30	0	0	0	0	0	0	0
09:00	0	0	0	0	0	0	0
09:30	0	0	0	0	0	0	0
10:00	0	0	0	0	0	0	0
10:30	2	2	0	0	0	0	4
11:00	3	1	0	0	0	0	4
11:30	4	2	0	0	0	0	6
12:00	3	1	0	0	0	0	4
12:30	4	2	0	0	0	0	6
13:00	4	1	0	0	0	0	5
13:30	5	1	0	0	0	0	6
14:00	4	1	0	0	0	0	5
14:30	5	1	0	0	0	0	6
15:00	5	0	0	0	0	0	5
15:30	5	0	0	0	0	0	5
16:00	4	0	0	0	0	0	4
16:30	4	0	0	0	0	0	4
17:00	2	0	0	0	0	0	2
17:30	1	0	0	0	0	0	1
18:00	1	0	0	0	0	0	1
18:30	0	0	0	0	0	0	0
19:00	0	0	0	0	0	0	0

Note: Count doesn't include two scrapped cars near to the garage

ZONE: 7

DATE: 28/09/2018

LOCATION: Bodicote Business Park

DAY: Friday

TIME	ZONE 7						TOTAL
	CAR	LGV	OGV1	OGV2	PSV	MCL	
07:00	0	0	0	0	0	0	0
07:30	0	0	0	0	0	0	0
08:00	0	0	0	0	0	0	0
08:30	0	0	0	0	0	0	0
09:00	0	0	0	0	0	0	0
09:30	0	0	0	0	0	0	0
10:00	0	0	0	0	0	0	0
10:30	1	1	1	0	0	0	3
11:00	1	1	1	0	0	0	3
11:30	1	1	1	0	0	0	3
12:00	1	1	1	0	0	0	3
12:30	1	1	1	0	0	0	3
13:00	2	1	1	0	0	0	4
13:30	0	1	1	0	0	0	2
14:00	2	1	1	0	0	0	4
14:30	2	1	1	0	0	0	4
15:00	2	1	1	0	0	0	4
15:30	2	1	1	0	0	0	4
16:00	2	1	1	0	0	0	4
16:30	2	1	1	0	0	0	4
17:00	2	1	1	0	0	0	4
17:30	2	0	1	0	0	0	3
18:00	2	0	1	0	0	0	3
18:30	2	0	1	0	0	0	3
19:00	2	0	1	0	0	0	3

Note: Count doesn't include one abandoned car.



**8643 / BODICOTE BUSINESS PARK
SEPTEMBER 2018
PARKING BEAT SURVEY**

ZONE: 8

DATE: 28/09/2018

LOCATION: Bodicote Business Park

DAY: Friday

TIME	ZONE 8						TOTAL
	CAR	LGV	OGV1	OGV2	PSV	MCL	
07:00	0	0	0	0	0	0	0
07:30	0	0	0	0	0	0	0
08:00	0	0	0	0	0	0	0
08:30	0	0	0	0	0	0	0
09:00	0	0	0	0	0	0	0
09:30	0	0	0	0	0	0	0
10:00	0	0	0	0	0	0	0
10:30	2	0	0	0	0	0	2
11:00	2	0	0	0	0	0	2
11:30	2	0	0	0	0	0	2
12:00	2	0	0	0	0	0	2
12:30	3	0	0	0	0	0	3
13:00	3	0	0	0	0	0	3
13:30	4	0	0	0	0	0	4
14:00	3	0	0	0	0	0	3
14:30	2	0	0	0	0	0	2
15:00	4	0	0	0	0	0	4
15:30	2	0	0	0	0	0	2
16:00	2	0	0	0	0	0	2
16:30	3	0	0	0	0	0	3
17:00	2	0	0	0	0	0	2
17:30	2	0	0	0	0	0	2
18:00	1	0	0	0	0	0	1
18:30	1	0	0	0	0	0	1
19:00	1	0	0	0	0	0	1



**8643 / BODICOTE BUSINESS PARK
 SEPTEMBER 2018
 PARKING BEAT SURVEY**

ZONE: 9

DATE: 28/09/2018

LOCATION: Bodicote Business Park

DAY: Friday

TIME	ZONE 9						TOTAL
	CAR	LGV	OGV1	OGV2	PSV	MCL	
07:00	0	0	0	0	0	0	0
07:30	0	0	0	0	0	0	0
08:00	0	0	0	0	0	0	0
08:30	0	0	0	0	0	0	0
09:00	0	0	0	0	0	0	0
09:30	0	0	0	0	0	0	0
10:00	0	0	0	0	0	0	0
10:30	5	0	0	0	0	0	5
11:00	6	0	0	0	0	0	6
11:30	7	0	0	0	0	0	7
12:00	7	0	0	0	0	0	7
12:30	8	0	0	0	0	0	8
13:00	9	0	0	0	0	0	9
13:30	9	0	0	0	0	0	9
14:00	7	0	0	0	0	0	7
14:30	8	0	0	0	0	0	8
15:00	8	0	0	0	0	0	8
15:30	7	0	0	0	0	0	7
16:00	5	0	0	0	0	0	5
16:30	5	0	0	0	0	0	5
17:00	5	0	0	0	0	0	5
17:30	0	3	0	0	0	0	3
18:00	0	2	0	0	0	0	2
18:30	0	2	0	0	0	0	2
19:00	0	2	0	0	0	0	2



**8643 / BODICOTE BUSINESS PARK
SEPTEMBER 2018
PARKING BEAT SURVEY**

ZONE: 10

DATE: 28/09/2018

LOCATION: Bodicote Business Park

DAY: Friday

TIME	ZONE 10						TOTAL
	CAR	LGV	OGV1	OGV2	PSV	MCL	
07:00	0	0	0	0	0	0	0
07:30	0	0	0	0	0	0	0
08:00	0	0	0	0	0	0	0
08:30	0	0	0	0	0	0	0
09:00	0	0	0	0	0	0	0
09:30	0	0	0	0	0	0	0
10:00	0	0	0	0	0	0	0
10:30	2	0	0	0	0	0	2
11:00	2	0	0	0	0	0	2
11:30	3	0	0	0	0	0	3
12:00	4	0	0	0	0	0	4
12:30	4	0	0	0	0	0	4
13:00	6	0	0	0	0	0	6
13:30	5	0	0	0	0	0	5
14:00	6	0	0	0	0	0	6
14:30	6	0	0	0	0	0	6
15:00	5	0	0	0	0	0	5
15:30	3	0	0	0	0	0	3
16:00	3	0	0	0	0	0	3
16:30	0	0	0	0	0	0	0
17:00	0	0	0	0	0	0	0
17:30	1	0	0	0	0	0	1
18:00	1	0	0	0	0	0	1
18:30	1	0	0	0	0	0	1
19:00	1	0	0	0	0	0	1



**8643 / BODICOTE BUSINESS PARK
 SEPTEMBER 2018
 PARKING BEAT SURVEY**

ZONE: 11

DATE: 28/09/2018

LOCATION: Bodicote Business Park

DAY: Friday

TIME	ZONE 11						TOTAL
	CAR	LGV	OGV1	OGV2	PSV	MCL	
07:00	0	0	0	0	0	0	0
07:30	0	0	0	0	0	0	0
08:00	0	0	0	0	0	0	0
08:30	0	0	0	0	0	0	0
09:00	0	0	0	0	0	0	0
09:30	0	0	0	0	0	0	0
10:00	0	0	0	0	0	0	0
10:30	1	0	0	0	0	0	1
11:00	1	0	0	0	0	0	1
11:30	1	0	0	0	0	0	1
12:00	1	0	0	0	0	0	1
12:30	2	0	0	0	0	0	2
13:00	2	0	0	0	0	0	2
13:30	2	0	0	0	0	0	2
14:00	1	0	0	0	0	0	1
14:30	2	0	0	0	0	0	2
15:00	2	0	0	0	0	0	2
15:30	2	0	0	0	0	0	2
16:00	2	0	0	0	0	0	2
16:30	2	0	0	0	0	0	2
17:00	2	0	0	0	0	0	2
17:30	2	0	0	0	0	0	2
18:00	2	0	0	0	0	0	2
18:30	2	0	0	0	0	0	2
19:00	2	0	0	0	0	0	2



**8643 / BODICOTE BUSINESS PARK
SEPTEMBER 2018
PARKING BEAT SURVEY**

ZONE: 12

DATE: 28/09/2018

LOCATION: Bodicote Business Park

DAY: Friday

TIME	ZONE 12						TOTAL
	CAR	LGV	OGV1	OGV2	PSV	MCL	
07:00	0	0	0	0	0	0	0
07:30	0	0	0	0	0	0	0
08:00	0	0	0	0	0	0	0
08:30	0	0	0	0	0	0	0
09:00	0	0	0	0	0	0	0
09:30	0	0	0	0	0	0	0
10:00	0	0	0	0	0	0	0
10:30	2	0	0	0	0	0	2
11:00	2	0	0	0	0	0	2
11:30	3	0	0	0	0	0	3
12:00	3	0	0	0	0	0	3
12:30	3	0	0	0	0	0	3
13:00	2	0	0	0	0	0	2
13:30	2	0	0	0	0	0	2
14:00	2	0	0	0	0	0	2
14:30	3	0	0	0	0	0	3
15:00	2	0	0	0	0	0	2
15:30	2	0	0	0	0	0	2
16:00	3	0	0	0	0	0	3
16:30	3	0	0	0	0	0	3
17:00	3	0	0	0	0	0	3
17:30	3	0	0	0	0	0	3
18:00	5	0	0	0	0	0	5
18:30	4	0	0	0	0	0	4
19:00	3	0	0	0	0	0	3



**8643 / BODICOTE BUSINESS PARK
SEPTEMBER 2018
PARKING BEAT SURVEY**

ZONE: 13

DATE: 28/09/2018

LOCATION: Bodicote Business Park

DAY: Friday

TIME	ZONE 13						TOTAL
	CAR	LGV	OGV1	OGV2	PSV	MCL	
07:00	0	0	0	0	0	0	0
07:30	0	0	0	0	0	0	0
08:00	0	0	0	0	0	0	0
08:30	0	0	0	0	0	0	0
09:00	0	0	0	0	0	0	0
09:30	0	0	0	0	0	0	0
10:00	0	0	0	0	0	0	0
10:30	0	0	0	0	0	0	0
11:00	0	0	0	0	0	0	0
11:30	0	0	0	0	0	0	0
12:00	0	0	0	0	0	0	0
12:30	0	0	0	0	0	0	0
13:00	0	0	0	0	0	0	0
13:30	0	0	0	0	0	0	0
14:00	0	0	0	0	0	0	0
14:30	0	0	0	0	0	0	0
15:00	0	0	0	0	0	0	0
15:30	0	0	0	0	0	0	0
16:00	0	0	0	0	0	0	0
16:30	0	0	0	0	0	0	0
17:00	0	0	0	0	0	0	0
17:30	0	0	0	0	0	0	0
18:00	0	0	0	0	0	0	0
18:30	0	0	0	0	0	0	0
19:00	0	0	0	0	0	0	0



**8643 / BODICOTE BUSINESS PARK
 SEPTEMBER 2018
 PARKING BEAT SURVEY**

ZONE: 14

DATE: 28/09/2018

LOCATION: Bodicote Business Park

DAY: Friday

TIME	ZONE 14						TOTAL
	CAR	LGV	OGV1	OGV2	PSV	MCL	
07:00	0	0	0	0	0	0	0
07:30	0	0	0	0	0	0	0
08:00	0	0	0	0	0	0	0
08:30	0	0	0	0	0	0	0
09:00	0	0	0	0	0	0	0
09:30	0	0	0	0	0	0	0
10:00	0	0	0	0	0	0	0
10:30	11	1	0	0	0	0	12
11:00	10	1	0	0	0	0	11
11:30	9	1	0	0	0	0	10
12:00	8	1	0	0	0	0	9
12:30	8	1	0	0	0	0	9
13:00	10	1	0	0	0	0	11
13:30	9	1	0	0	0	0	10
14:00	11	1	0	0	0	0	12
14:30	8	0	0	0	0	0	8
15:00	5	0	0	0	0	0	5
15:30	5	0	0	0	0	0	5
16:00	5	0	0	0	0	0	5
16:30	5	0	0	0	0	0	5
17:00	4	0	0	0	0	0	4
17:30	3	0	0	0	0	0	3
18:00	4	0	0	0	0	0	4
18:30	3	0	0	0	0	0	3
19:00	3	3	0	0	0	0	6



8643 / BODICOTE BUSINESS PARK
SEPTEMBER 2018
PARKING BEAT SURVEY

ZONE: 1

DATE: 29/09/2018

LOCATION: Bodicote Business Park

DAY: Saturday

TIME	ZONE 1						TOTAL
	CAR	LGV	OGV1	OGV2	PSV	MCL	
07:00	0	0	1	0	0	0	1
07:30	0	0	1	0	0	0	1
08:00	0	0	1	0	0	0	1
08:30	0	0	1	0	0	0	1
09:00	1	0	0	0	0	0	1
09:30	1	0	0	0	0	0	1
10:00	1	0	0	0	0	0	1
10:30	1	1	1	0	0	0	3
11:00	1	0	1	0	0	0	2
11:30	1	0	1	0	0	0	2
12:00	1	0	1	0	0	0	2
12:30	0	0	1	0	0	0	1
13:00	0	0	1	0	0	0	1
13:30	0	0	1	0	0	0	1
14:00	0	0	1	0	0	0	1
14:30	0	0	1	0	0	0	1
15:00	0	0	1	0	0	0	1
15:30	0	0	1	0	0	0	1
16:00	0	0	1	0	0	0	1
16:30	0	0	1	0	0	0	1
17:00	0	0	1	0	0	0	1
17:30	0	0	1	0	0	0	1
18:00	0	0	1	0	0	0	1
18:30	0	0	1	0	0	0	1
19:00	0	0	1	0	0	0	1



8643 / BODICOTE BUSINESS PARK
SEPTEMBER 2018
PARKING BEAT SURVEY

ZONE: 2

DATE: 29/09/2018

LOCATION: Bodicote Business Park

DAY: Saturday

TIME	ZONE 2						TOTAL
	CAR	LGV	OGV1	OGV2	PSV	MCL	
07:00	1	0	0	0	0	0	1
07:30	1	0	0	0	0	0	1
08:00	1	0	0	0	0	0	1
08:30	3	0	0	0	0	0	3
09:00	16	0	1	0	0	0	17
09:30	20	2	0	0	0	0	22
10:00	28	2	1	0	0	0	31
10:30	32	2	0	0	0	0	34
11:00	31	2	0	0	0	0	33
11:30	33	3	0	0	0	0	36
12:00	30	2	0	0	0	0	32
12:30	31	2	0	0	0	0	33
13:00	27	2	0	0	0	0	29
13:30	25	2	0	0	0	0	27
14:00	23	2	0	0	0	0	25
14:30	21	1	0	0	0	0	22
15:00	16	3	2	0	0	0	21
15:30	12	2	2	0	0	0	16
16:00	10	0	0	0	0	0	10
16:30	10	0	0	0	0	0	10
17:00	9	0	0	0	0	0	9
17:30	9	0	0	0	0	0	9
18:00	8	0	0	0	0	0	8
18:30	7	1	0	0	0	0	8
19:00	6	0	0	0	0	0	6



8643 / BODICOTE BUSINESS PARK
SEPTEMBER 2018
PARKING BEAT SURVEY

ZONE: 3

DATE: 29/09/2018

LOCATION: Bodicote Business Park

DAY: Saturday

TIME	ZONE 3						TOTAL
	CAR	LGV	OGV1	OGV2	PSV	MCL	
07:00	1	0	0	0	0	0	1
07:30	1	0	0	0	0	0	1
08:00	1	0	0	0	0	0	1
08:30	1	0	0	0	0	0	1
09:00	2	0	0	0	0	0	2
09:30	2	0	0	0	0	0	2
10:00	3	0	0	0	0	0	3
10:30	3	0	0	0	0	0	3
11:00	3	0	0	0	0	0	3
11:30	2	0	0	0	0	0	2
12:00	2	0	0	0	0	0	2
12:30	2	0	0	0	0	0	2
13:00	2	0	0	0	0	0	2
13:30	1	0	0	0	0	0	1
14:00	1	0	0	0	0	0	1
14:30	1	0	0	0	0	0	1
15:00	2	0	0	0	0	0	2
15:30	2	0	0	0	0	0	2
16:00	2	0	0	0	0	0	2
16:30	1	0	0	0	0	0	1
17:00	1	0	0	0	0	0	1
17:30	0	0	0	0	0	0	0
18:00	0	0	0	0	0	0	0
18:30	0	0	0	0	0	0	0
19:00	0	0	0	0	0	0	0



**8643 / BODICOTE BUSINESS PARK
SEPTEMBER 2018
PARKING BEAT SURVEY**

ZONE: 4

DATE: 29/09/2018

LOCATION: Bodicote Business Park

DAY: Saturday

TIME	ZONE 4						TOTAL
	CAR	LGV	OGV1	OGV2	PSV	MCL	
07:00	2	0	0	0	0	0	2
07:30	2	0	0	0	0	0	2
08:00	2	0	0	0	0	0	2
08:30	2	0	0	0	0	0	2
09:00	1	0	0	0	0	0	1
09:30	1	0	0	0	0	0	1
10:00	2	0	0	0	0	0	2
10:30	3	0	0	0	0	0	3
11:00	3	0	0	0	0	0	3
11:30	3	0	0	0	0	0	3
12:00	3	0	0	0	0	0	3
12:30	3	0	0	0	0	0	3
13:00	2	0	0	0	0	0	2
13:30	3	0	0	0	0	0	3
14:00	2	0	0	0	0	0	2
14:30	1	0	0	0	0	0	1
15:00	1	0	0	0	0	0	1
15:30	2	0	0	0	0	0	2
16:00	2	0	0	0	0	0	2
16:30	1	0	0	0	0	0	1
17:00	1	0	0	0	0	0	1
17:30	1	0	0	0	0	0	1
18:00	1	0	0	0	0	0	1
18:30	1	0	0	0	0	0	1
19:00	1	0	0	0	0	0	1



8643 / BODICOTE BUSINESS PARK
SEPTEMBER 2018
PARKING BEAT SURVEY

ZONE: 5

DATE: 29/09/2018

LOCATION: Bodicote Business Park

DAY: Saturday

TIME	ZONE 5						TOTAL
	CAR	LGV	OGV1	OGV2	PSV	MCL	
07:00	0	0	0	0	0	0	0
07:30	1	0	0	0	0	0	1
08:00	1	0	0	0	0	0	1
08:30	2	0	0	0	0	0	2
09:00	2	0	0	0	0	0	2
09:30	2	0	0	0	0	0	2
10:00	2	0	0	0	0	0	2
10:30	2	0	0	0	0	0	2
11:00	2	0	0	0	0	0	2
11:30	2	0	0	0	0	0	2
12:00	2	0	0	0	0	0	2
12:30	2	0	0	0	0	0	2
13:00	2	0	0	0	0	0	2
13:30	2	0	0	0	0	0	2
14:00	2	0	0	0	0	0	2
14:30	2	0	0	0	0	0	2
15:00	2	0	0	0	0	0	2
15:30	1	0	0	0	0	0	1
16:00	1	0	0	0	0	0	1
16:30	1	0	0	0	0	0	1
17:00	0	0	0	0	0	0	0
17:30	0	0	0	0	0	0	0
18:00	0	0	0	0	0	0	0
18:30	0	0	0	0	0	0	0
19:00	0	0	0	0	0	0	0



**8643 / BODICOTE BUSINESS PARK
SEPTEMBER 2018
PARKING BEAT SURVEY**

ZONE: 6

DATE: 29/09/2018

LOCATION: Bodicote Business Park

DAY: Saturday

TIME	ZONE 6						TOTAL
	CAR	LGV	OGV1	OGV2	PSV	MCL	
07:00	1	0	0	0	0	0	1
07:30	1	0	0	0	0	0	1
08:00	1	0	0	0	0	0	1
08:30	1	0	0	0	0	0	1
09:00	1	0	0	0	0	0	1
09:30	0	0	0	0	0	0	0
10:00	1	0	0	0	0	0	1
10:30	1	0	0	0	0	0	1
11:00	1	0	0	0	0	0	1
11:30	1	0	0	0	0	0	1
12:00	1	0	0	0	0	0	1
12:30	1	0	0	0	0	0	1
13:00	1	0	0	0	0	0	1
13:30	1	0	0	0	0	0	1
14:00	1	0	0	0	0	0	1
14:30	1	0	0	0	0	0	1
15:00	1	0	0	0	0	0	1
15:30	0	0	0	0	0	0	0
16:00	1	0	0	0	0	0	1
16:30	1	0	0	0	0	0	1
17:00	1	0	0	0	0	0	1
17:30	0	0	0	0	0	0	0
18:00	0	0	0	0	0	0	0
18:30	0	0	0	0	0	0	0
19:00	0	0	0	0	0	0	0

Note: Count doesn't include two scrapped cars near to the garage



**8643 / BODICOTE BUSINESS PARK
SEPTEMBER 2018
PARKING BEAT SURVEY**

ZONE: 7

DATE: 29/09/2018

LOCATION: Bodicote Business Park

DAY: Saturday

TIME	ZONE 7						TOTAL
	CAR	LGV	OGV1	OGV2	PSV	MCL	
07:00	1	0	0	0	0	0	1
07:30	1	0	0	0	0	0	1
08:00	2	0	0	0	0	0	2
08:30	3	0	0	0	0	0	3
09:00	3	0	0	0	0	0	3
09:30	4	0	0	0	0	0	4
10:00	4	0	0	0	0	0	4
10:30	5	0	0	0	0	0	5
11:00	6	0	0	0	0	0	6
11:30	6	0	0	0	0	0	6
12:00	5	0	0	0	0	0	5
12:30	5	0	0	0	0	0	5
13:00	4	0	0	0	0	0	4
13:30	4	0	0	0	0	0	4
14:00	5	0	0	0	0	0	5
14:30	4	0	0	0	0	0	4
15:00	4	0	0	0	0	0	4
15:30	3	0	0	0	0	0	3
16:00	2	0	0	0	0	0	2
16:30	2	0	0	0	0	0	2
17:00	2	0	0	0	0	0	2
17:30	2	0	0	0	0	0	2
18:00	2	0	0	0	0	0	2
18:30	2	0	0	0	0	0	2
19:00	2	0	0	0	0	0	2

Note: Count doesn't include one abandoned car.



8643 / BODICOTE BUSINESS PARK
SEPTEMBER 2018
PARKING BEAT SURVEY

ZONE: 8

DATE: 29/09/2018

LOCATION: Bodicote Business Park

DAY: Saturday

TIME	ZONE 8						TOTAL
	CAR	LGV	OGV1	OGV2	PSV	MCL	
07:00	0	0	0	0	0	0	0
07:30	0	0	0	0	0	0	0
08:00	0	0	0	0	0	0	0
08:30	0	0	0	0	0	0	0
09:00	1	0	0	0	0	0	1
09:30	1	0	0	0	0	0	1
10:00	1	0	0	0	0	0	1
10:30	1	0	0	0	0	0	1
11:00	1	0	0	0	0	0	1
11:30	1	0	0	0	0	0	1
12:00	1	0	0	0	0	0	1
12:30	1	0	0	0	0	0	1
13:00	1	0	0	0	0	0	1
13:30	1	0	0	0	0	0	1
14:00	1	0	0	0	0	0	1
14:30	1	0	0	0	0	0	1
15:00	1	0	0	0	0	0	1
15:30	0	0	0	0	0	0	0
16:00	0	0	0	0	0	0	0
16:30	0	0	0	0	0	0	0
17:00	0	0	0	0	0	0	0
17:30	0	0	0	0	0	0	0
18:00	0	0	0	0	0	0	0
18:30	0	0	0	0	0	0	0
19:00	0	0	0	0	0	0	0



**8643 / BODICOTE BUSINESS PARK
SEPTEMBER 2018
PARKING BEAT SURVEY**

ZONE: 9

DATE: 29/09/2018

LOCATION: Bodicote Business Park

DAY: Saturday

TIME	ZONE 9						TOTAL
	CAR	LGV	OGV1	OGV2	PSV	MCL	
07:00	3	0	0	0	0	0	3
07:30	3	0	0	0	0	0	3
08:00	3	0	0	0	0	0	3
08:30	4	0	0	0	0	0	4
09:00	5	2	0	0	0	0	7
09:30	7	2	0	0	0	0	9
10:00	6	2	0	0	0	0	8
10:30	6	2	0	0	0	0	8
11:00	6	2	0	0	0	0	8
11:30	5	2	0	0	0	0	7
12:00	5	2	0	0	0	0	7
12:30	5	2	0	0	0	0	7
13:00	6	2	0	0	0	0	8
13:30	5	1	0	0	0	0	6
14:00	5	2	0	0	0	0	7
14:30	4	2	0	0	0	0	6
15:00	5	2	0	0	0	0	7
15:30	4	1	0	0	0	0	5
16:00	5	2	0	0	0	0	7
16:30	4	2	0	0	0	0	6
17:00	5	2	0	0	0	0	7
17:30	4	2	0	0	0	0	6
18:00	3	0	0	0	0	0	3
18:30	2	0	0	0	0	0	2
19:00	2	0	0	0	0	0	2



**8643 / BODICOTE BUSINESS PARK
SEPTEMBER 2018
PARKING BEAT SURVEY**

ZONE: 10

DATE: 29/09/2018

LOCATION: Bodicote Business Park

DAY: Saturday

TIME	ZONE 10						TOTAL
	CAR	LGV	OGV1	OGV2	PSV	MCL	
07:00	1	0	0	0	0	0	1
07:30	1	0	0	0	0	0	1
08:00	1	0	0	0	0	0	1
08:30	1	0	0	0	0	0	1
09:00	1	0	0	0	0	0	1
09:30	1	0	0	0	0	0	1
10:00	2	0	0	0	0	0	2
10:30	2	0	0	0	0	0	2
11:00	2	0	0	0	0	0	2
11:30	2	0	0	0	0	0	2
12:00	1	0	0	0	0	0	1
12:30	1	0	0	0	0	0	1
13:00	1	0	0	0	0	0	1
13:30	2	0	0	0	0	0	2
14:00	2	0	0	0	0	0	2
14:30	1	0	0	0	0	0	1
15:00	1	0	0	0	0	0	1
15:30	1	0	0	0	0	0	1
16:00	1	0	0	0	0	0	1
16:30	1	0	0	0	0	0	1
17:00	1	0	0	0	0	0	1
17:30	1	0	0	0	0	0	1
18:00	1	0	0	0	0	0	1
18:30	0	0	0	0	0	0	0
19:00	0	0	0	0	0	0	0



**8643 / BODICOTE BUSINESS PARK
SEPTEMBER 2018
PARKING BEAT SURVEY**

ZONE: 11

DATE: 29/09/2018

LOCATION: Bodicote Business Park

DAY: Saturday

TIME	ZONE 11						TOTAL
	CAR	LGV	OGV1	OGV2	PSV	MCL	
07:00	0	1	0	0	0	0	1
07:30	0	1	0	0	0	0	1
08:00	1	1	0	0	0	0	2
08:30	1	1	0	0	0	0	2
09:00	1	1	0	0	0	0	2
09:30	2	1	0	0	0	0	3
10:00	2	1	0	0	0	0	3
10:30	2	1	0	0	0	0	3
11:00	2	1	0	0	0	0	3
11:30	2	1	0	0	0	0	3
12:00	1	1	0	0	0	0	2
12:30	1	1	0	0	0	0	2
13:00	1	1	0	0	0	0	2
13:30	1	1	0	0	0	0	2
14:00	1	1	0	0	0	0	2
14:30	1	1	0	0	0	0	2
15:00	1	1	0	0	0	0	2
15:30	1	1	0	0	0	0	2
16:00	1	1	0	0	0	0	2
16:30	1	1	0	0	0	0	2
17:00	1	1	0	0	0	0	2
17:30	1	1	0	0	0	0	2
18:00	1	1	0	0	0	0	2
18:30	1	1	0	0	0	0	2
19:00	1	1	0	0	0	0	2



8643 / BODICOTE BUSINESS PARK
SEPTEMBER 2018
PARKING BEAT SURVEY

ZONE: 12

DATE: 29/09/2018

LOCATION: Bodicote Business Park

DAY: Saturday

TIME	ZONE 12						TOTAL
	CAR	LGV	OGV1	OGV2	PSV	MCL	
07:00	6	0	0	0	0	0	6
07:30	6	0	0	0	0	0	6
08:00	6	0	0	0	0	0	6
08:30	6	0	0	0	0	0	6
09:00	7	0	0	0	0	0	7
09:30	6	0	0	0	0	0	6
10:00	5	0	0	0	0	0	5
10:30	5	0	0	0	0	0	5
11:00	5	0	0	0	0	0	5
11:30	4	0	0	0	0	0	4
12:00	6	0	0	0	0	0	6
12:30	5	0	0	0	0	0	5
13:00	4	0	0	0	0	0	4
13:30	5	0	0	0	0	0	5
14:00	4	0	0	0	0	0	4
14:30	4	0	0	0	0	0	4
15:00	4	0	0	0	0	0	4
15:30	4	0	0	0	0	0	4
16:00	8	0	0	0	0	0	8
16:30	8	0	0	0	0	0	8
17:00	8	0	0	0	0	0	8
17:30	8	0	0	0	0	0	8
18:00	8	0	0	0	0	0	8
18:30	8	0	0	0	0	0	8
19:00	7	0	0	0	0	0	7



8643 / BODICOTE BUSINESS PARK
SEPTEMBER 2018
PARKING BEAT SURVEY

ZONE: 13

DATE: 29/09/2018

LOCATION: Bodicote Business Park

DAY: Saturday

TIME	ZONE 13						TOTAL
	CAR	LGV	OGV1	OGV2	PSV	MCL	
07:00	0	0	0	0	0	0	0
07:30	0	0	0	0	0	0	0
08:00	0	0	0	0	0	0	0
08:30	0	0	0	0	0	0	0
09:00	0	0	0	0	0	0	0
09:30	0	0	0	0	0	0	0
10:00	0	0	0	0	0	0	0
10:30	0	0	0	0	0	0	0
11:00	0	0	0	0	0	0	0
11:30	0	0	0	0	0	0	0
12:00	0	0	0	0	0	0	0
12:30	0	0	0	0	0	0	0
13:00	0	0	0	0	0	0	0
13:30	0	0	0	0	0	0	0
14:00	0	0	0	0	0	0	0
14:30	0	0	0	0	0	0	0
15:00	0	0	0	0	0	0	0
15:30	0	0	0	0	0	0	0
16:00	0	0	0	0	0	0	0
16:30	0	0	0	0	0	0	0
17:00	0	0	0	0	0	0	0
17:30	0	0	0	0	0	0	0
18:00	0	0	0	0	0	0	0
18:30	0	0	0	0	0	0	0
19:00	0	0	0	0	0	0	0



**8643 / BODICOTE BUSINESS PARK
SEPTEMBER 2018
PARKING BEAT SURVEY**

ZONE: 14

DATE: 29/09/2018

LOCATION: Bodicote Business Park

DAY: Saturday

TIME	ZONE 14						TOTAL
	CAR	LGV	OGV1	OGV2	PSV	MCL	
07:00	2	0	0	0	0	0	2
07:30	2	0	0	0	0	0	2
08:00	2	0	0	0	0	0	2
08:30	4	0	0	0	0	0	4
09:00	6	0	0	0	0	0	6
09:30	6	0	0	0	0	0	6
10:00	10	0	0	0	0	0	10
10:30	11	0	0	0	0	0	11
11:00	12	0	0	0	0	0	12
11:30	11	0	0	0	0	0	11
12:00	11	1	0	0	0	0	12
12:30	10	0	0	0	0	0	10
13:00	9	1	0	0	0	0	10
13:30	12	0	0	0	0	0	12
14:00	12	0	0	0	0	0	12
14:30	14	2	0	0	0	0	16
15:00	13	0	0	0	0	0	13
15:30	12	1	0	0	0	0	13
16:00	11	0	0	0	0	0	11
16:30	11	1	0	0	0	0	12
17:00	12	0	0	0	0	0	12
17:30	0	0	0	0	0	0	0
18:00	0	0	0	0	0	0	0
18:30	0	0	0	0	0	0	0
19:00	0	0	0	0	0	0	0

Appendix D – Manual Classified Count Data



SITE: 2

DATE: 28/09/2018

LOCATION: Internal junction

DAY: Friday

TIME	A to E							TOT	A to D							TOT
	CAR	LGV	OGV1	OGV2	PSV	MCL	PCL		CAR	LGV	OGV1	OGV2	PSV	MCL	PCL	
16:00	4	0	0	0	0	0	0	4	2	1	0	0	0	0	0	3
16:15	5	2	0	0	0	0	0	7	3	1	0	0	0	0	0	4
16:30	9	0	0	0	0	0	0	9	4	0	0	0	0	0	0	4
16:45	3	0	0	0	0	0	0	3	12	1	0	0	0	0	0	13
17:00	3	0	0	0	0	0	0	3	7	1	0	0	0	0	0	8
17:15	1	0	0	0	0	0	0	1	6	0	0	0	0	0	0	6
17:30	3	1	0	0	0	0	0	4	6	0	0	0	0	1	0	7
17:45	2	1	0	0	0	0	0	3	7	0	0	0	0	0	0	7
18:00	3	0	0	0	0	0	0	3	4	0	0	0	0	0	0	4
18:15	0	0	0	0	0	0	0	0	3	0	0	0	0	0	0	3
18:30	0	0	0	0	0	0	0	0	8	0	0	0	0	0	0	8
18:45	0	0	0	0	0	0	0	0	9	1	0	0	0	0	0	10
P/TOT	33	4	0	0	0	0	0	37	71	5	0	0	0	1	0	77



SITE: 2

DATE: 28/09/2018

LOCATION: Internal junction

DAY: Friday

TIME	A to C							TOT	A to B							TOT
	CAR	LGV	OGV1	OGV2	PSV	MCL	PCL		CAR	LGV	OGV1	OGV2	PSV	MCL	PCL	
16:00	0	0	0	0	0	0	0	0	1	0	0	0	0	0	0	1
16:15	0	0	0	0	0	0	0	0	1	0	0	0	0	0	0	1
16:30	0	0	0	0	0	0	0	0	2	0	0	0	0	0	0	2
16:45	0	0	0	0	0	0	0	0	0	0	0	0	0	0	0	0
17:00	0	0	0	0	0	0	0	0	0	0	0	0	0	0	0	0
17:15	0	0	0	0	0	0	0	0	1	0	0	0	0	0	0	1
17:30	0	0	0	0	0	0	0	0	1	0	0	0	0	0	0	1
17:45	0	0	0	0	0	0	0	0	1	0	0	0	0	0	0	1
18:00	0	0	0	0	0	0	0	0	1	0	0	0	0	0	0	1
18:15	0	0	0	0	0	0	0	0	0	0	0	0	0	0	0	0
18:30	0	0	0	0	0	0	0	0	0	0	0	0	0	0	0	0
18:45	0	0	0	0	0	0	0	0	0	1	0	0	0	0	0	1
P/TOT	0	0	0	0	0	0	0	0	8	1	0	0	0	0	0	9



SITE: 2

DATE: 28/09/2018

LOCATION: Internal junction

DAY: Friday

TIME	B to A							TOT	B to E							TOT
	CAR	LGV	OGV1	OGV2	PSV	MCL	PCL		CAR	LGV	OGV1	OGV2	PSV	MCL	PCL	
16:00	0	0	0	0	0	0	0	0	0	0	0	0	0	0	0	0
16:15	6	0	0	0	0	0	0	6	0	0	0	0	0	0	0	0
16:30	3	1	0	0	0	0	0	4	0	0	0	0	0	0	0	0
16:45	2	0	0	0	0	0	0	2	0	0	0	0	0	0	0	0
17:00	0	0	0	0	0	0	0	0	0	0	0	0	0	0	0	0
17:15	1	0	0	0	0	0	0	1	0	0	0	0	0	0	0	0
17:30	1	0	0	0	0	0	0	1	0	0	0	0	0	0	0	0
17:45	1	0	0	0	0	0	0	1	0	0	0	0	0	0	0	0
18:00	0	0	1	0	0	0	0	1	0	0	0	0	0	0	0	0
18:15	0	0	0	0	0	0	0	0	0	0	0	0	0	0	0	0
18:30	0	0	0	0	0	0	0	0	0	0	0	0	0	0	0	0
18:45	1	0	0	0	0	0	0	1	0	0	0	0	0	0	0	0
P/TOT	15	1	1	0	0	0	0	17	0	0	0	0	0	0	0	0



SITE: 2

DATE: 28/09/2018

LOCATION: Internal junction

DAY: Friday

TIME	B to D								TOT	B to C								TOT	
	CAR	LGV	OGV1	OGV2	PSV	MCL	PCL	TOT		CAR	LGV	OGV1	OGV2	PSV	MCL	PCL	TOT		
16:00	0	0	0	0	0	0	0	0	0	0	0	0	0	0	0	0	0	0	0
16:15	0	0	0	0	0	0	0	0	0	0	0	0	0	0	0	0	0	0	0
16:30	0	0	0	0	0	0	0	0	0	0	0	0	0	0	0	0	0	0	0
16:45	0	0	0	0	0	0	0	0	0	0	0	0	0	0	0	0	0	0	0
17:00	0	0	0	0	0	0	0	0	0	0	0	0	0	0	0	0	0	0	0
17:15	0	0	0	0	0	0	0	0	0	0	0	0	0	0	0	0	0	0	0
17:30	0	0	0	0	0	0	0	0	0	0	0	0	0	0	0	0	0	0	0
17:45	0	0	0	0	0	0	0	0	0	0	0	0	0	0	0	0	0	0	0
18:00	0	0	0	0	0	0	0	0	0	0	0	0	0	0	0	0	0	0	0
18:15	0	0	0	0	0	0	0	0	0	0	0	0	0	0	0	0	0	0	0
18:30	0	0	0	0	0	0	0	0	0	0	0	0	0	0	0	0	0	0	0
18:45	0	0	0	0	0	0	0	0	0	0	0	0	0	0	0	0	0	0	0
P/TOT	0	0	0	0	0	0	0	0	0	0	0	0	0	0	0	0	0	0	0



SITE: 2

DATE: 28/09/2018

LOCATION: Internal junction

DAY: Friday

TIME	C to B								TOT	C to A								TOT	
	CAR	LGV	OGV1	OGV2	PSV	MCL	PCL	TOT		CAR	LGV	OGV1	OGV2	PSV	MCL	PCL	TOT		
16:00	0	0	0	0	0	0	0	0	0	0	0	0	0	0	0	0	0	0	0
16:15	0	0	0	0	0	0	0	0	0	0	1	0	0	0	0	0	0	0	1
16:30	0	0	0	0	0	0	0	0	0	0	0	0	0	0	0	0	0	0	0
16:45	0	0	0	0	0	0	0	0	0	0	0	0	0	0	0	0	0	0	0
17:00	0	0	0	0	0	0	0	0	0	0	0	0	0	0	0	0	0	0	0
17:15	0	0	0	0	0	0	0	0	0	0	0	0	0	0	0	0	0	0	0
17:30	0	0	0	0	0	0	0	0	0	0	0	0	0	0	0	0	0	0	0
17:45	0	0	0	0	0	0	0	0	0	0	0	0	0	0	0	0	0	0	0
18:00	0	0	0	0	0	0	0	0	0	0	0	0	0	0	0	0	0	0	0
18:15	0	0	0	0	0	0	0	0	0	0	0	0	0	0	0	0	0	0	0
18:30	0	0	0	0	0	0	0	0	0	0	0	0	0	0	0	0	0	0	0
18:45	0	0	0	0	0	0	0	0	0	0	0	0	0	0	0	0	0	0	0
P/TOT	0	0	0	0	0	0	0	0	0	0	1	0	0	0	0	0	0	0	1



SITE: 2

DATE: 28/09/2018

LOCATION: Internal junction

DAY: Friday

TIME	C to E								TOT	C to D								TOT
	CAR	LGV	OGV1	OGV2	PSV	MCL	PCL	CAR		LGV	OGV1	OGV2	PSV	MCL	PCL			
16:00	0	0	0	0	0	0	0	0	0	0	0	0	0	0	0	0	0	0
16:15	0	0	0	0	0	0	0	0	0	0	0	0	0	0	0	0	0	0
16:30	0	0	0	0	0	0	0	0	0	0	0	0	0	0	0	0	0	0
16:45	0	0	0	0	0	0	0	0	0	0	0	0	0	0	0	0	0	0
17:00	0	0	0	0	0	0	0	0	0	0	0	0	0	0	0	0	0	0
17:15	0	0	0	0	0	0	0	0	0	0	0	0	0	0	0	0	0	0
17:30	0	0	0	0	0	0	0	0	0	0	0	0	0	0	0	0	0	0
17:45	0	0	0	0	0	0	0	0	0	0	0	0	0	0	0	0	0	0
18:00	0	0	0	0	0	0	0	0	0	0	0	0	0	0	0	0	0	0
18:15	0	0	0	0	0	0	0	0	0	0	0	0	0	0	0	0	0	0
18:30	0	0	0	0	0	0	0	0	0	0	0	0	0	0	0	0	0	0
18:45	0	0	0	0	0	0	0	0	0	0	0	0	0	0	0	0	0	0
P/TOT	0	0	0	0	0	0	0	0	0	0	0	0	0	0	0	0	0	0



SITE: 2

DATE: 28/09/2018

LOCATION: Internal junction

DAY: Friday

TIME	D to C								TOT	D to B								TOT
	CAR	LGV	OGV1	OGV2	PSV	MCL	PCL	CAR		LGV	OGV1	OGV2	PSV	MCL	PCL			
16:00	0	0	0	0	0	0	0	0	0	0	0	0	0	0	0	0	0	0
16:15	0	0	0	0	0	0	0	0	0	0	0	0	0	0	0	0	0	0
16:30	0	0	0	0	0	0	0	0	0	0	0	0	0	0	0	0	0	0
16:45	0	0	0	0	0	0	0	0	0	0	0	0	0	0	0	0	0	0
17:00	0	0	0	0	0	0	0	0	0	0	0	0	0	0	0	0	0	0
17:15	0	0	0	0	0	0	0	0	0	0	0	0	0	0	0	0	0	0
17:30	0	0	0	0	0	0	0	0	0	0	0	0	0	0	0	0	0	0
17:45	0	0	0	0	0	0	0	0	0	0	0	0	0	0	0	0	0	0
18:00	0	0	0	0	0	0	0	0	0	0	0	0	0	0	0	0	0	0
18:15	0	0	0	0	0	0	0	0	0	0	0	0	0	0	0	0	0	0
18:30	0	0	0	0	0	0	0	0	0	0	0	0	0	0	0	0	0	0
18:45	0	0	0	0	0	0	0	0	0	0	0	0	0	0	0	0	0	0
P/TOT	0	0	0	0	0	0	0	0	0	0	0	0	0	0	0	0	0	0



SITE: 2

DATE: 28/09/2018

LOCATION: Internal junction

DAY: Friday

TIME	D to A								TOT	D to E								TOT
	CAR	LGV	OGV1	OGV2	PSV	MCL	PCL	CAR		LGV	OGV1	OGV2	PSV	MCL	PCL			
16:00	2	1	0	0	0	0	0	3	0	0	0	0	0	0	0	0		
16:15	1	1	0	0	0	0	0	2	0	0	0	0	0	0	0	0		
16:30	2	0	0	0	0	0	1	3	0	0	0	0	0	0	0	0		
16:45	2	0	0	0	0	0	0	2	0	0	0	0	0	0	0	0		
17:00	3	0	0	0	0	0	1	4	0	0	0	0	0	0	0	0		
17:15	3	0	0	0	0	1	0	4	0	0	0	0	0	0	0	0		
17:30	6	1	0	0	0	0	0	7	0	0	0	0	0	0	0	0		
17:45	4	2	0	0	0	0	0	6	0	0	0	0	0	0	0	0		
18:00	1	0	0	0	0	1	0	2	0	0	0	0	0	0	0	0		
18:15	2	0	0	0	0	0	0	2	0	0	0	0	0	0	0	0		
18:30	2	1	0	0	0	0	0	3	0	0	0	0	0	0	0	0		
18:45	4	1	0	0	0	1	0	6	0	0	0	0	0	0	0	0		
P/TOT	32	7	0	0	0	3	2	44	0	0	0	0	0	0	0	0		



SITE: 2

DATE: 28/09/2018

LOCATION: Internal junction

DAY: Friday

TIME	E to D								TOT	E to C								TOT
	CAR	LGV	OGV1	OGV2	PSV	MCL	PCL	TOT		CAR	LGV	OGV1	OGV2	PSV	MCL	PCL	TOT	
16:00	0	0	0	0	0	0	0	0	0	1	0	0	0	0	0	0	1	
16:15	0	0	0	0	0	0	0	0	0	0	0	0	0	0	0	0	0	
16:30	0	0	0	0	0	0	0	0	0	0	0	0	0	0	0	0	0	
16:45	0	0	0	0	0	0	0	0	0	0	0	0	0	0	0	0	0	
17:00	0	0	0	0	0	0	0	0	0	0	0	0	0	0	0	0	0	
17:15	0	0	0	0	0	0	0	0	0	0	0	0	0	0	0	0	0	
17:30	0	0	0	0	0	0	0	0	0	0	0	0	0	0	0	0	0	
17:45	0	0	0	0	0	0	0	0	0	0	0	0	0	0	0	0	0	
18:00	0	0	0	0	0	0	0	0	0	0	0	0	0	0	0	0	0	
18:15	0	0	0	0	0	0	0	0	0	0	0	0	0	0	0	0	0	
18:30	0	0	0	0	0	0	0	0	0	0	0	0	0	0	0	0	0	
18:45	0	0	0	0	0	0	0	0	0	0	0	0	0	0	0	0	0	
P/TOT	0	0	0	0	0	0	0	0	0	1	0	0	0	0	0	0	1	



SITE: 2

DATE: 28/09/2018

LOCATION: Internal junction

DAY: Friday

TIME	E to B								TOT	E to A								TOT
	CAR	LGV	OGV1	OGV2	PSV	MCL	PCL	TOT		CAR	LGV	OGV1	OGV2	PSV	MCL	PCL	TOT	
16:00	0	0	0	0	0	0	0	0	0	11	1	0	0	0	0	0	12	
16:15	0	0	0	0	0	0	0	0	0	9	1	0	0	0	1	0	11	
16:30	0	0	0	0	0	0	0	0	0	16	3	0	0	0	0	0	19	
16:45	0	0	0	0	0	0	0	0	0	11	1	0	0	0	0	0	12	
17:00	0	0	0	0	0	0	0	0	0	11	1	0	0	0	0	0	12	
17:15	0	0	0	0	0	0	0	0	0	3	1	0	0	0	0	0	4	
17:30	0	0	0	0	0	0	0	0	0	4	0	0	0	0	1	0	5	
17:45	0	0	0	0	0	0	0	0	0	4	2	0	0	0	0	0	6	
18:00	0	0	0	0	0	0	0	0	0	3	0	0	0	0	0	0	3	
18:15	0	0	0	0	0	0	0	0	0	0	0	0	0	0	0	0	0	
18:30	0	0	0	0	0	0	0	0	0	1	0	0	0	0	0	0	1	
18:45	0	0	0	0	0	0	0	0	0	0	0	0	0	0	0	0	0	
P/TOT	0	0	0	0	0	0	0	0	0	73	10	0	0	0	2	0	85	



SITE: 2

DATE: 28/09/2018

LOCATION: Internal junction

DAY: Friday

TIME	TO ARM A							TOT	FROM ARM A							TOT
	CAR	LGV	OGV1	OGV2	PSV	MCL	PCL		CAR	LGV	OGV1	OGV2	PSV	MCL	PCL	
16:00	13	2	0	0	0	0	0	15	7	1	0	0	0	0	0	8
16:15	17	2	0	0	0	1	0	20	9	3	0	0	0	0	0	12
16:30	21	4	0	0	0	0	1	26	15	0	0	0	0	0	0	15
16:45	15	1	0	0	0	0	0	16	15	1	0	0	0	0	0	16
17:00	14	1	0	0	0	0	1	16	10	1	0	0	0	0	0	11
17:15	7	1	0	0	0	1	0	9	8	0	0	0	0	0	0	8
17:30	11	1	0	0	0	1	0	13	10	1	0	0	0	1	0	12
17:45	9	4	0	0	0	0	0	13	10	1	0	0	0	0	0	11
18:00	4	0	1	0	0	1	0	6	8	0	0	0	0	0	0	8
18:15	2	0	0	0	0	0	0	2	3	0	0	0	0	0	0	3
18:30	3	1	0	0	0	0	0	4	8	0	0	0	0	0	0	8
18:45	5	1	0	0	0	1	0	7	9	2	0	0	0	0	0	11
P/TOT	121	18	1	0	0	5	2	147	112	10	0	0	0	1	0	123



SITE: 2

DATE: 28/09/2018

LOCATION: Internal junction

DAY: Friday

TIME	TO ARM B							TOT	FROM ARM B							TOT	
	CAR	LGV	OGV1	OGV2	PSV	MCL	PCL		CAR	LGV	OGV1	OGV2	PSV	MCL	PCL		
16:00	1	0	0	0	0	0	0	1	0	0	0	0	0	0	0	0	0
16:15	1	0	0	0	0	0	0	1	6	0	0	0	0	0	0	0	6
16:30	2	0	0	0	0	0	0	2	3	1	0	0	0	0	0	0	4
16:45	0	0	0	0	0	0	0	0	2	0	0	0	0	0	0	0	2
17:00	0	0	0	0	0	0	0	0	0	0	0	0	0	0	0	0	0
17:15	1	0	0	0	0	0	0	1	1	0	0	0	0	0	0	0	1
17:30	1	0	0	0	0	0	0	1	1	0	0	0	0	0	0	0	1
17:45	1	0	0	0	0	0	0	1	1	0	0	0	0	0	0	0	1
18:00	1	0	0	0	0	0	0	1	0	0	1	0	0	0	0	0	1
18:15	0	0	0	0	0	0	0	0	0	0	0	0	0	0	0	0	0
18:30	0	0	0	0	0	0	0	0	0	0	0	0	0	0	0	0	0
18:45	0	1	0	0	0	0	0	1	1	0	0	0	0	0	0	0	1
P/TOT	8	1	0	0	0	0	0	9	15	1	1	0	0	0	0	0	17



SITE: 2

DATE: 28/09/2018

LOCATION: Internal junction

DAY: Friday

TIME	TO ARM C							TOT	FROM ARM C							TOT	
	CAR	LGV	OGV1	OGV2	PSV	MCL	PCL		CAR	LGV	OGV1	OGV2	PSV	MCL	PCL		
16:00	1	0	0	0	0	0	0	1	0	0	0	0	0	0	0	0	0
16:15	0	0	0	0	0	0	0	0	1	0	0	0	0	0	0	0	1
16:30	0	0	0	0	0	0	0	0	0	0	0	0	0	0	0	0	0
16:45	0	0	0	0	0	0	0	0	0	0	0	0	0	0	0	0	0
17:00	0	0	0	0	0	0	0	0	0	0	0	0	0	0	0	0	0
17:15	0	0	0	0	0	0	0	0	0	0	0	0	0	0	0	0	0
17:30	0	0	0	0	0	0	0	0	0	0	0	0	0	0	0	0	0
17:45	0	0	0	0	0	0	0	0	0	0	0	0	0	0	0	0	0
18:00	0	0	0	0	0	0	0	0	0	0	0	0	0	0	0	0	0
18:15	0	0	0	0	0	0	0	0	0	0	0	0	0	0	0	0	0
18:30	0	0	0	0	0	0	0	0	0	0	0	0	0	0	0	0	0
18:45	0	0	0	0	0	0	0	0	0	0	0	0	0	0	0	0	0
P/TOT	1	0	0	0	0	0	0	1	1	0	0	0	0	0	0	0	1



SITE: 2

DATE: 28/09/2018

LOCATION: Internal junction

DAY: Friday

TIME	TO ARM D							TOT	FROM ARM D							TOT
	CAR	LGV	OGV1	OGV2	PSV	MCL	PCL		CAR	LGV	OGV1	OGV2	PSV	MCL	PCL	
16:00	2	1	0	0	0	0	0	3	2	1	0	0	0	0	0	3
16:15	3	1	0	0	0	0	0	4	1	1	0	0	0	0	0	2
16:30	4	0	0	0	0	0	0	4	2	0	0	0	0	0	1	3
16:45	12	1	0	0	0	0	0	13	2	0	0	0	0	0	0	2
17:00	7	1	0	0	0	0	0	8	3	0	0	0	0	0	1	4
17:15	6	0	0	0	0	0	0	6	3	0	0	0	0	1	0	4
17:30	6	0	0	0	0	0	1	7	6	1	0	0	0	0	0	7
17:45	7	0	0	0	0	0	0	7	4	2	0	0	0	0	0	6
18:00	4	0	0	0	0	0	0	4	1	0	0	0	0	1	0	2
18:15	3	0	0	0	0	0	0	3	2	0	0	0	0	0	0	2
18:30	8	0	0	0	0	0	0	8	2	1	0	0	0	0	0	3
18:45	9	1	0	0	0	0	0	10	4	1	0	0	0	1	0	6
P/TOT	71	5	0	0	0	0	1	77	32	7	0	0	0	3	2	44



SITE: 2

DATE: 28/09/2018

LOCATION: Internal junction

DAY: Friday

TIME	TO ARM E							TOT	FROM ARM E							TOT
	CAR	LGV	OGV1	OGV2	PSV	MCL	PCL		CAR	LGV	OGV1	OGV2	PSV	MCL	PCL	
16:00	4	0	0	0	0	0	0	4	12	1	0	0	0	0	0	13
16:15	5	2	0	0	0	0	0	7	9	1	0	0	0	1	0	11
16:30	9	0	0	0	0	0	0	9	16	3	0	0	0	0	0	19
16:45	3	0	0	0	0	0	0	3	11	1	0	0	0	0	0	12
17:00	3	0	0	0	0	0	0	3	11	1	0	0	0	0	0	12
17:15	1	0	0	0	0	0	0	1	3	1	0	0	0	0	0	4
17:30	3	1	0	0	0	0	0	4	4	0	0	0	0	1	0	5
17:45	2	1	0	0	0	0	0	3	4	2	0	0	0	0	0	6
18:00	3	0	0	0	0	0	0	3	3	0	0	0	0	0	0	3
18:15	0	0	0	0	0	0	0	0	0	0	0	0	0	0	0	0
18:30	0	0	0	0	0	0	0	0	1	0	0	0	0	0	0	1
18:45	0	0	0	0	0	0	0	0	0	0	0	0	0	0	0	0
P/TOT	33	4	0	0	0	0	0	37	74	10	0	0	0	2	0	86



SITE: 2

DATE: 28/09/2018

LOCATION: Internal junction

DAY: Friday

TIME	JUNCTION TOTAL							TOT
	CAR	LGV	OGV1	OGV2	PSV	MCL	PCL	
16:00	21	3	0	0	0	0	0	24
16:15	26	5	0	0	0	1	0	32
16:30	36	4	0	0	0	0	1	41
16:45	30	2	0	0	0	0	0	32
17:00	24	2	0	0	0	0	1	27
17:15	15	1	0	0	0	1	0	17
17:30	21	2	0	0	0	2	0	25
17:45	19	5	0	0	0	0	0	24
18:00	12	0	1	0	0	1	0	14
18:15	5	0	0	0	0	0	0	5
18:30	11	1	0	0	0	0	0	12
18:45	14	3	0	0	0	1	0	18
P/TOT	234	28	1	0	0	6	2	271

PEAK HOUR CALCULATION	
16:00 to 17:00	129
16:15 to 17:15	132
16:30 to 17:30	117
16:45 to 17:45	101
17:00 to 18:00	93
17:15 to 18:15	80
17:30 to 18:30	68
17:45 to 18:45	55
18:00 to 19:00	49
PEAK VALUE	132

Appendix E – Automatic Traffic Count Data

Site No.	Location.	Direction.	Speed Limit - PSL (mph)	Start Date.	End Date.	Total Vehicles.	5 Day Ave.	7 Day Ave.	No. > Speed Limit.	% > Speed Limit.	No. > ACPO Limit.	% > ACPO Limit.	No. > DfT Limit.	% > DfT Limit.	Mean Speed	85%ile Speed
1	Access Road, Att - Sign, OSGR: SP 46789 37517	Eastbound	30	26 September 2018	02 October 2018	4068	616	581	82	2.0	20	0.5	0	0.0	18.5	23.7
		Westbound	30	26 September 2018	02 October 2018	4092	617	585	25	0.6	1	0.0	0	0.0	17.9	22.1
		Two way	30	26 September 2018	02 October 2018	8160	1233	1166	107	1.3	21	0.3	0	0.0	18.2	23.0

Site 1
 Location Access Road, Att - Sign, OSGR: SP 46789 37517
 Direction Eastbound

8643 / Bodicote Business Park, Banbury
 September 2018
 Automatic Traffic Count

26 September 2018

Time	Total	Classification												>PSL 30	>PSL% 30	>SL1 35 ACPO	>SL1% 35 ACPO	>SL2 45 DfT	>SL2% 45 DfT	Mean	Vpp 85
		1 MCL	2 SV	3 SVT	4 TB2	5 TB3	6 T4	7 ART3	8 ART4	9 ART5	10 ART6	11 BD	12 DRT								
0000	0	0	0	0	0	0	0	0	0	0	0	0	0	0	0	0	0	0	-	-	
0100	0	0	0	0	0	0	0	0	0	0	0	0	0	0	0	0	0	0	-	-	
0200	0	0	0	0	0	0	0	0	0	0	0	0	0	0	0	0	0	0	-	-	
0300	0	0	0	0	0	0	0	0	0	0	0	0	0	0	0	0	0	0	-	-	
0400	1	0	1	0	0	0	0	0	0	0	0	0	0	0	0	0	0	0	24.5	-	
0500	2	0	1	0	1	0	0	0	0	0	0	0	0	0	0	0	0	0	19.3	-	
0600	14	0	13	0	0	1	0	0	0	0	0	0	0	1	7.1	0	0	0	22.7	26.8	
0700	33	0	31	1	0	0	1	0	0	0	0	0	0	3	9.1	1	3	0	22.7	26.8	
0800	34	0	33	0	1	0	0	0	0	0	0	0	0	0	0	0	0	0	22.2	27.1	
0900	30	0	26	0	4	0	0	0	0	0	0	0	0	0	0	0	0	0	17.6	22.8	
1000	37	0	32	0	4	0	0	0	1	0	0	0	0	0	0	0	0	0	17.4	20.1	
1100	57	0	53	0	4	0	0	0	0	0	0	0	0	0	0	0	0	0	13.7	16.8	
1200	73	1	66	0	6	0	0	0	0	0	0	0	0	2	2.7	0	0	0	15.7	20.1	
1300	71	1	65	0	5	0	0	0	0	0	0	0	0	2	2.8	0	0	0	16.5	21	
1400	63	0	59	0	4	0	0	0	0	0	0	0	0	0	0	0	0	0	17.7	22.8	
1500	61	0	57	0	4	0	0	0	0	0	0	0	0	1	1.6	0	0	0	18.4	22.6	
1600	54	1	49	1	3	0	0	0	0	0	0	0	0	0	0	0	0	0	17.3	20.4	
1700	46	0	44	0	2	0	0	0	0	0	0	0	0	1	2.2	0	0	0	19	22.8	
1800	45	1	44	0	0	0	0	0	0	0	0	0	0	0	0	0	0	0	19.3	22.4	
1900	29	1	28	0	0	0	0	0	0	0	0	0	0	0	0	0	0	0	19.3	23.5	
2000	15	0	15	0	0	0	0	0	0	0	0	0	0	0	0	0	0	0	23.5	26.6	
2100	2	0	2	0	0	0	0	0	0	0	0	0	0	0	0	0	0	0	24.9	-	
2200	4	0	4	0	0	0	0	0	0	0	0	0	0	0	0	0	0	0	18.7	-	
2300	0	0	0	0	0	0	0	0	0	0	0	0	0	0	0	0	0	0	-	-	
07-19	604	4	559	2	37	0	1	0	1	0	0	0	0	9	1.5	1	0.2	0	17.7	22.8	
06-22	664	5	617	2	37	1	1	0	1	0	0	0	0	10	1.5	1	0.2	0	18	23.3	
06-00	668	5	621	2	37	1	1	0	1	0	0	0	0	10	1.5	1	0.1	0	18	23.3	
00-00	671	5	623	2	38	1	1	0	1	0	0	0	0	10	1.5	1	0.1	0	18	23.3	



Site 1
 Location Access Road, Att - Sign, OSGR: SP 46789 37517
 Direction Eastbound

8643 / Bodicote Business Park, Banbury
 September 2018
 Automatic Traffic Count

27 September 2018

Time	Total	Classification												>PSL 30	>PSL% 30	>SL1 35 ACPO	>SL1% 35 ACPO	>SL2 45 DfT	>SL2% 45 DfT	Mean	Vpp 85
		1 MCL	2 SV	3 SVT	4 TB2	5 TB3	6 T4	7 ART3	8 ART4	9 ART5	10 ART6	11 BD	12 DRT								
0000	0	0	0	0	0	0	0	0	0	0	0	0	0	0	0	0	0	0	-	-	
0100	0	0	0	0	0	0	0	0	0	0	0	0	0	0	0	0	0	0	-	-	
0200	0	0	0	0	0	0	0	0	0	0	0	0	0	0	0	0	0	0	-	-	
0300	0	0	0	0	0	0	0	0	0	0	0	0	0	0	0	0	0	0	-	-	
0400	1	0	1	0	0	0	0	0	0	0	0	0	0	0	0	0	0	0	23.6	-	
0500	1	0	1	0	0	0	0	0	0	0	0	0	0	0	0	0	0	0	18.9	-	
0600	12	0	11	0	1	0	0	0	0	0	0	0	0	0	0	0	0	0	23.9	29.3	
0700	34	1	32	0	1	0	0	0	0	0	0	0	0	0	0	0	0	0	22.4	26.2	
0800	37	0	36	0	1	0	0	0	0	0	0	0	0	3	8.1	0	0	0	23.1	26.6	
0900	33	0	29	0	2	1	1	0	0	0	0	0	0	0	0	0	0	0	19.3	21.9	
1000	38	0	34	0	3	1	0	0	0	0	0	0	0	1	2.6	0	0	0	17.1	19.7	
1100	45	1	41	0	2	1	0	0	0	0	0	0	0	0	0	0	0	0	17.8	20.1	
1200	70	1	64	0	5	0	0	0	0	0	0	0	0	2	2.9	1	1.4	0	17.2	21.7	
1300	56	0	50	0	5	1	0	0	0	0	0	0	0	0	0	0	0	0	16.9	23.5	
1400	66	0	62	0	4	0	0	0	0	0	0	0	0	0	0	0	0	0	18.1	21.9	
1500	82	1	69	0	8	0	4	0	0	0	0	0	0	0	0	0	0	0	16.8	21.3	
1600	51	1	48	0	1	0	0	0	1	0	0	0	0	2	3.9	0	0	0	19	23.7	
1700	39	2	34	0	3	0	0	0	0	0	0	0	0	1	2.6	1	2.6	0	19.1	24.4	
1800	21	0	19	0	2	0	0	0	0	0	0	0	0	0	0	0	0	0	22.8	26.4	
1900	18	0	18	0	0	0	0	0	0	0	0	0	0	0	0	0	0	0	21	25.3	
2000	10	0	10	0	0	0	0	0	0	0	0	0	0	2	20	1	10	0	26.1	-	
2100	4	0	4	0	0	0	0	0	0	0	0	0	0	1	25	0	0	0	24.4	-	
2200	4	0	4	0	0	0	0	0	0	0	0	0	0	0	0	0	0	0	19.1	-	
2300	1	0	1	0	0	0	0	0	0	0	0	0	0	0	0	0	0	0	17.7	-	
07-19	572	7	518	0	37	4	5	0	1	0	0	0	0	9	1.6	2	0.3	0	18.6	23.7	
06-22	616	7	561	0	38	4	5	0	1	0	0	0	0	12	1.9	3	0.5	0	18.9	24.4	
06-00	621	7	566	0	38	4	5	0	1	0	0	0	0	12	1.9	3	0.5	0	18.9	24.2	
00-00	623	7	568	0	38	4	5	0	1	0	0	0	0	12	1.9	3	0.5	0	18.9	24.2	



Site 1
 Location Access Road, Att - Sign, OSGR: SP 46789 37517
 Direction Eastbound

8643 / Bodicote Business Park, Banbury
 September 2018
 Automatic Traffic Count

28 September 2018

Time	Total	Classification												>PSL 30	>PSL% 30	>SL1 35 ACPO	>SL1% 35 ACPO	>SL2 45 DfT	>SL2% 45 DfT	Mean	Vpp 85
		1 MCL	2 SV	3 SVT	4 TB2	5 TB3	6 T4	7 ART3	8 ART4	9 ART5	10 ART6	11 BD	12 DRT								
0000	0	0	0	0	0	0	0	0	0	0	0	0	0	0	0	0	0	0	-	-	
0100	1	0	1	0	0	0	0	0	0	0	0	0	0	0	0	0	0	0	21.9	-	
0200	1	0	1	0	0	0	0	0	0	0	0	0	0	0	0	0	0	0	19.5	-	
0300	0	0	0	0	0	0	0	0	0	0	0	0	0	0	0	0	0	0	-	-	
0400	2	0	1	0	1	0	0	0	0	0	0	0	0	0	0	0	0	0	27.5	-	
0500	5	0	3	0	2	0	0	0	0	0	0	0	0	0	0	0	0	0	19.9	-	
0600	11	0	11	0	0	0	0	0	0	0	0	0	0	1	9.1	0	0	0	22.1	24.8	
0700	40	0	36	1	2	1	0	0	0	0	0	0	0	2	5	0	0	0	22.1	26.8	
0800	49	0	47	0	1	0	1	0	0	0	0	0	0	1	2	1	2	0	22	25.7	
0900	39	0	34	0	3	0	2	0	0	0	0	0	0	0	0	0	0	0	17.9	22.6	
1000	50	0	45	0	3	0	2	0	0	0	0	0	0	0	0	0	0	0	16	19.5	
1100	78	0	75	1	2	0	0	0	0	0	0	0	0	1	1.3	1	1.3	0	0	16.5	19.2
1200	63	0	55	0	7	0	1	0	0	0	0	0	0	3	4.8	1	1.6	0	0	18	23
1300	68	0	64	0	2	1	1	0	0	0	0	0	0	0	0	0	0	0	0	17	22.6
1400	51	3	44	0	4	0	0	0	0	0	0	0	0	1	2	0	0	0	0	17	22.6
1500	76	0	73	0	3	0	0	0	0	0	0	0	0	0	0	0	0	0	0	17.8	22.4
1600	74	2	67	0	5	0	0	0	0	0	0	0	0	1	1.4	1	1.4	0	0	16.9	20.1
1700	51	2	45	0	4	0	0	0	0	0	0	0	0	2	3.9	0	0	0	0	20	26.6
1800	19	2	17	0	0	0	0	0	0	0	0	0	0	1	5.3	1	5.3	0	0	20.2	23.9
1900	18	0	18	0	0	0	0	0	0	0	0	0	0	1	5.6	0	0	0	0	19.8	23.7
2000	13	0	12	0	0	1	0	0	0	0	0	0	0	0	0	0	0	0	0	20.6	23
2100	8	0	8	0	0	0	0	0	0	0	0	0	0	0	0	0	0	0	0	20.7	-
2200	13	0	13	0	0	0	0	0	0	0	0	0	0	0	0	0	0	0	0	19.8	21
2300	3	0	3	0	0	0	0	0	0	0	0	0	0	0	0	0	0	0	0	21.7	-
07-19	658	9	602	2	36	2	7	0	0	0	0	0	0	12	1.8	5	0.8	0	0	18.1	23
06-22	708	9	651	2	36	3	7	0	0	0	0	0	0	14	2	5	0.7	0	0	18.3	23.3
06-00	724	9	667	2	36	3	7	0	0	0	0	0	0	14	1.9	5	0.7	0	0	18.3	23.3
00-00	733	9	673	2	39	3	7	0	0	0	0	0	0	14	1.9	5	0.7	0	0	18.4	23.5



Site 1
 Location Access Road, Att - Sign, OSGR: SP 46789 37517
 Direction Eastbound

8643 / Bodicote Business Park, Banbury
 September 2018
 Automatic Traffic Count

29 September 2018

Time	Total	Classification												>PSL 30	>PSL% 30	>SL1 35 ACPO	>SL1% 35 ACPO	>SL2 45 DfT	>SL2% 45 DfT	Mean	Vpp 85
		1 MCL	2 SV	3 SVT	4 TB2	5 TB3	6 T4	7 ART3	8 ART4	9 ART5	10 ART6	11 BD	12 DRT								
0000	2	0	2	0	0	0	0	0	0	0	0	0	0	0	0	0	0	0	19.3	-	
0100	1	0	1	0	0	0	0	0	0	0	0	0	0	0	0	0	0	0	13.8	-	
0200	1	0	0	0	1	0	0	0	0	0	0	0	0	0	0	0	0	0	19.1	-	
0300	1	0	1	0	0	0	0	0	0	0	0	0	0	0	0	0	0	0	19.6	-	
0400	2	0	2	0	0	0	0	0	0	0	0	0	0	0	0	0	0	0	19.7	-	
0500	1	0	1	0	0	0	0	0	0	0	0	0	0	0	0	0	0	0	22.8	-	
0600	4	0	4	0	0	0	0	0	0	0	0	0	0	0	0	0	0	0	22	-	
0700	7	0	7	0	0	0	0	0	0	0	0	0	0	0	0	0	0	0	21.7	-	
0800	26	0	25	0	1	0	0	0	0	0	0	0	0	0	0	0	0	0	22.1	25.9	
0900	33	0	32	0	1	0	0	0	0	0	0	0	0	0	0	0	0	0	20.1	23.3	
1000	53	1	52	0	0	0	0	0	0	0	0	0	0	3	5.7	0	0	0	17.8	21.9	
1100	79	5	67	0	3	0	1	0	0	0	2	0	1	1	1.3	0	0	0	17.5	22.6	
1200	66	0	63	0	2	0	1	0	0	0	0	0	0	0	0	0	0	0	16.4	22.1	
1300	57	0	55	0	2	0	0	0	0	0	0	0	0	1	1.8	0	0	0	17.1	21.3	
1400	60	0	58	1	1	0	0	0	0	0	0	0	0	1	1.7	0	0	0	16.8	21	
1500	56	0	51	0	5	0	0	0	0	0	0	0	0	1	1.8	0	0	0	16.9	21.9	
1600	53	1	45	1	6	0	0	0	0	0	0	0	0	2	3.8	2	3.8	0	18	24.2	
1700	43	0	40	0	3	0	0	0	0	0	0	0	0	0	0	0	0	0	19.3	23.9	
1800	39	0	38	0	1	0	0	0	0	0	0	0	0	1	2.6	1	2.6	0	19.6	24.2	
1900	36	1	34	0	1	0	0	0	0	0	0	0	0	0	0	0	0	0	19.9	23.7	
2000	15	0	14	0	1	0	0	0	0	0	0	0	0	1	6.7	1	6.7	0	22.3	23.9	
2100	12	0	12	0	0	0	0	0	0	0	0	0	0	1	8.3	1	8.3	0	22.1	23.5	
2200	7	0	7	0	0	0	0	0	0	0	0	0	0	0	0	0	0	0	22.6	-	
2300	3	0	3	0	0	0	0	0	0	0	0	0	0	0	0	0	0	0	18.6	-	
07-19	572	7	533	2	25	0	2	0	0	0	2	0	1	10	1.7	3	0.5	0	18	23.3	
06-22	639	8	597	2	27	0	2	0	0	0	2	0	1	12	1.9	5	0.8	0	18.3	23.5	
06-00	649	8	607	2	27	0	2	0	0	0	2	0	1	12	1.8	5	0.8	0	18.3	23.5	
00-00	657	8	614	2	28	0	2	0	0	0	2	0	1	12	1.8	5	0.8	0	18.3	23.5	



Site 1
 Location Access Road, Att - Sign, OSGR: SP 46789 37517
 Direction Eastbound

8643 / Bodicote Business Park, Banbury
 September 2018
 Automatic Traffic Count

30 September 2018

Time	Total	Classification												>PSL 30	>PSL% 30	>SL1 35 ACPO	>SL1% 35 ACPO	>SL2 45 DfT	>SL2% 45 DfT	Mean	Vpp 85
		1 MCL	2 SV	3 SVT	4 TB2	5 TB3	6 T4	7 ART3	8 ART4	9 ART5	10 ART6	11 BD	12 DRT								
0000	2	0	2	0	0	0	0	0	0	0	0	0	0	0	0	0	0	0	21.5	-	
0100	2	0	2	0	0	0	0	0	0	0	0	0	0	0	0	0	0	0	24.5	-	
0200	1	0	1	0	0	0	0	0	0	0	0	0	0	0	0	0	0	0	22.9	-	
0300	0	0	0	0	0	0	0	0	0	0	0	0	0	0	0	0	0	0	-	-	
0400	2	0	2	0	0	0	0	0	0	0	0	0	0	0	0	0	0	0	22	-	
0500	1	0	1	0	0	0	0	0	0	0	0	0	0	0	0	0	0	0	20.2	-	
0600	1	0	1	0	0	0	0	0	0	0	0	0	0	0	0	0	0	0	21.9	-	
0700	2	0	2	0	0	0	0	0	0	0	0	0	0	0	0	0	0	0	21.9	-	
0800	6	0	5	1	0	0	0	0	0	0	0	0	0	0	0	0	0	0	22	-	
0900	17	0	17	0	0	0	0	0	0	0	0	0	0	0	0	0	0	0	21.2	23.5	
1000	35	0	35	0	0	0	0	0	0	0	0	0	0	0	0	0	0	0	16.8	21.9	
1100	43	0	43	0	0	0	0	0	0	0	0	0	0	0	0	0	0	0	17.7	24.4	
1200	42	0	40	0	2	0	0	0	0	0	0	0	0	0	0	0	0	0	16.2	21.5	
1300	41	0	41	0	0	0	0	0	0	0	0	0	0	1	2.4	0	0	0	17.1	23	
1400	35	0	35	0	0	0	0	0	0	0	0	0	0	2	5.7	1	2.9	0	17.8	23.3	
1500	27	0	25	0	2	0	0	0	0	0	0	0	0	0	0	0	0	0	16.7	24.4	
1600	14	0	13	0	1	0	0	0	0	0	0	0	0	0	0	0	0	0	19.6	22.1	
1700	20	0	20	0	0	0	0	0	0	0	0	0	0	1	5	0	0	0	21.8	26.6	
1800	12	0	12	0	0	0	0	0	0	0	0	0	0	0	0	0	0	0	20.4	25.7	
1900	7	0	7	0	0	0	0	0	0	0	0	0	0	0	0	0	0	0	22.2	-	
2000	9	1	8	0	0	0	0	0	0	0	0	0	0	2	22.2	0	0	0	23.3	-	
2100	8	0	8	0	0	0	0	0	0	0	0	0	0	0	0	0	0	0	22.1	-	
2200	2	0	2	0	0	0	0	0	0	0	0	0	0	0	0	0	0	0	16.1	-	
2300	0	0	0	0	0	0	0	0	0	0	0	0	0	0	0	0	0	0	-	-	
07-19	294	0	288	1	5	0	0	0	0	0	0	0	0	4	1.4	1	0.3	0	18	23.7	
06-22	319	1	312	1	5	0	0	0	0	0	0	0	0	6	1.9	1	0.3	0	18.4	24.2	
06-00	321	1	314	1	5	0	0	0	0	0	0	0	0	6	1.9	1	0.3	0	18.4	24.2	
00-00	329	1	322	1	5	0	0	0	0	0	0	0	0	6	1.8	1	0.3	0	18.5	24.2	



Site 1
 Location Access Road, Att - Sign, OSGR: SP 46789 37517
 Direction Eastbound

8643 / Bodicote Business Park, Banbury
 September 2018
 Automatic Traffic Count

01 October 2018

Time	Total	Classification												>PSL 30	>PSL% 30	>SL1 35 ACPO	>SL1% 35 ACPO	>SL2 45 DfT	>SL2% 45 DfT	Mean	Vpp 85
		1 MCL	2 SV	3 SVT	4 TB2	5 TB3	6 T4	7 ART3	8 ART4	9 ART5	10 ART6	11 BD	12 DRT								
0000	1	0	1	0	0	0	0	0	0	0	0	0	0	0	0	0	0	0	23.5	-	
0100	0	0	0	0	0	0	0	0	0	0	0	0	0	0	0	0	0	0	-	-	
0200	0	0	0	0	0	0	0	0	0	0	0	0	0	0	0	0	0	0	-	-	
0300	1	0	1	0	0	0	0	0	0	0	0	0	0	0	0	0	0	0	24	-	
0400	2	0	2	0	0	0	0	0	0	0	0	0	0	0	0	0	0	0	21.6	-	
0500	2	0	2	0	0	0	0	0	0	0	0	0	0	0	0	0	0	0	24.8	-	
0600	11	0	10	0	1	0	0	0	0	0	0	0	0	1	9.1	0	0	0	22.9	24.8	
0700	39	0	34	1	2	1	0	0	0	0	1	0	0	0	0	0	0	0	21	25.9	
0800	36	0	36	0	0	0	0	0	0	0	0	0	0	2	5.6	0	0	0	23.9	27.7	
0900	24	0	21	0	3	0	0	0	0	0	0	0	0	1	4.2	0	0	0	21.2	25.5	
1000	48	0	46	0	2	0	0	0	0	0	0	0	0	1	2.1	1	2.1	0	18.5	24.6	
1100	54	0	49	0	5	0	0	0	0	0	0	0	0	0	0	0	0	0	16.4	21	
1200	45	0	39	0	6	0	0	0	0	0	0	0	0	0	0	0	0	0	16.6	19.5	
1300	49	0	43	0	5	0	1	0	0	0	0	0	0	0	0	0	0	0	17	22.4	
1400	41	1	39	1	0	0	0	0	0	0	0	0	0	0	0	0	0	0	17.4	22.6	
1500	56	0	50	1	4	1	0	0	0	0	0	0	0	0	0	0	0	0	16.9	21.3	
1600	40	0	36	0	4	0	0	0	0	0	0	0	0	3	7.5	1	2.5	0	20.2	23	
1700	34	3	30	0	1	0	0	0	0	0	0	0	0	4	11.8	0	0	0	19.8	25.1	
1800	24	1	22	0	1	0	0	0	0	0	0	0	0	1	4.2	0	0	0	21	24.6	
1900	18	0	17	1	0	0	0	0	0	0	0	0	0	1	5.6	0	0	0	23.1	26.8	
2000	5	0	5	0	0	0	0	0	0	0	0	0	0	0	0	0	0	0	17.4	-	
2100	6	0	6	0	0	0	0	0	0	0	0	0	0	0	0	0	0	0	21.7	-	
2200	1	0	1	0	0	0	0	0	0	0	0	0	0	0	0	0	0	0	20.9	-	
2300	0	0	0	0	0	0	0	0	0	0	0	0	0	0	0	0	0	0	-	-	
07-19	490	5	445	3	33	2	1	0	0	0	1	0	0	12	2.4	2	0.4	0	18.8	24.2	
06-22	530	5	483	4	34	2	1	0	0	0	1	0	0	14	2.6	2	0.4	0	19	24.4	
06-00	531	5	484	4	34	2	1	0	0	0	1	0	0	14	2.6	2	0.4	0	19	24.4	
00-00	537	5	490	4	34	2	1	0	0	0	1	0	0	14	2.6	2	0.4	0	19.1	24.4	



Site 1
 Location Access Road, Att - Sign, OSGR: SP 46789 37517
 Direction Eastbound

8643 / Bodicote Business Park, Banbury
 September 2018
 Automatic Traffic Count

02 October 2018

Time	Total	Classification												>PSL 30	>PSL% 30	>SL1 35 ACPO	>SL1% 35 ACPO	>SL2 45 DfT	>SL2% 45 DfT	Mean	Vpp 85
		1 MCL	2 SV	3 SVT	4 TB2	5 TB3	6 T4	7 ART3	8 ART4	9 ART5	10 ART6	11 BD	12 DRT								
0000	1	0	1	0	0	0	0	0	0	0	0	0	0	0	0	0	0	0	17.3	-	
0100	0	0	0	0	0	0	0	0	0	0	0	0	0	0	0	0	0	0	-	-	
0200	0	0	0	0	0	0	0	0	0	0	0	0	0	0	0	0	0	0	-	-	
0300	0	0	0	0	0	0	0	0	0	0	0	0	0	0	0	0	0	0	-	-	
0400	2	0	2	0	0	0	0	0	0	0	0	0	0	0	0	0	0	0	21.4	-	
0500	1	0	1	0	0	0	0	0	0	0	0	0	0	0	0	0	0	0	21.4	-	
0600	10	0	10	0	0	0	0	0	0	0	0	0	0	0	0	0	0	0	21.8	-	
0700	33	0	31	0	2	0	0	0	0	0	0	0	0	1	3	0	0	0	21.1	24.2	
0800	43	0	42	0	1	0	0	0	0	0	0	0	0	2	4.7	0	0	0	22.4	26.6	
0900	24	0	22	0	2	0	0	0	0	0	0	0	0	0	0	0	0	0	17	19.5	
1000	40	2	35	0	3	0	0	0	0	0	0	0	0	1	2.5	1	2.5	0	15.3	18.8	
1100	50	2	39	0	9	0	0	0	0	0	0	0	0	0	0	0	0	0	16.8	21.9	
1200	42	0	35	1	6	0	0	0	0	0	0	0	0	1	2.4	0	0	0	17.8	23	
1300	49	0	44	0	4	1	0	0	0	0	0	0	0	2	4.1	1	2	0	17.7	21.3	
1400	48	0	41	1	5	0	1	0	0	0	0	0	0	0	0	0	0	0	15.7	18.6	
1500	53	0	46	0	4	2	1	0	0	0	0	0	0	0	0	0	0	0	16.4	21.3	
1600	46	0	41	1	4	0	0	0	0	0	0	0	0	0	0	0	0	0	17	22.1	
1700	23	2	19	0	2	0	0	0	0	0	0	0	0	4	17.4	1	4.3	0	22.8	30	
1800	19	0	18	0	1	0	0	0	0	0	0	0	0	1	5.3	0	0	0	23.1	28.6	
1900	15	1	14	0	0	0	0	0	0	0	0	0	0	0	0	0	0	0	20	24.8	
2000	9	0	9	0	0	0	0	0	0	0	0	0	0	1	11.1	0	0	0	21.6	-	
2100	7	0	7	0	0	0	0	0	0	0	0	0	0	1	14.3	0	0	0	22.5	-	
2200	3	1	2	0	0	0	0	0	0	0	0	0	0	0	0	0	0	0	18.8	-	
2300	0	0	0	0	0	0	0	0	0	0	0	0	0	0	0	0	0	0	0	0	
07-19	470	6	413	3	43	3	2	0	0	0	0	0	0	12	2.6	3	0.6	0	0	18.1	23.9
06-22	511	7	453	3	43	3	2	0	0	0	0	0	0	14	2.7	3	0.6	0	0	18.3	23.9
06-00	514	8	455	3	43	3	2	0	0	0	0	0	0	14	2.7	3	0.6	0	0	18.3	23.9
00-00	518	8	459	3	43	3	2	0	0	0	0	0	0	14	2.7	3	0.6	0	0	18.4	23.9



Site 1
 Location Access Road, Att - Sign, OSGR: SP 46789 37517
 Direction Eastbound

8643 / Bodicote Business Park, Banbury
 September 2018
 Automatic Traffic Count

Virtual Day (7)

Time	Total	Classification												>PSL 30	>PSL% 30	>SL1 35 ACPO	>SL1% 35 ACPO	>SL2 45 DfT	>SL2% 45 DfT	Mean	Vpp 85
		1 MCL	2 SV	3 SVT	4 TB2	5 TB3	6 T4	7 ART3	8 ART4	9 ART5	10 ART6	11 BD	12 DRT								
0000	1	0	1	0	0	0	0	0	0	0	0	0	0	0	0	0	0	0	20.4	-	
0100	1	0	1	0	0	0	0	0	0	0	0	0	0	0	0	0	0	0	21.2	-	
0200	0	0	0	0	0	0	0	0	0	0	0	0	0	0	0	0	0	0	20.5	-	
0300	0	0	0	0	0	0	0	0	0	0	0	0	0	0	0	0	0	0	21.8	-	
0400	2	0	2	0	0	0	0	0	0	0	0	0	0	0	0	0	0	0	22.7	-	
0500	2	0	1	0	0	0	0	0	0	0	0	0	0	0	0	0	0	0	20.9	-	
0600	9	0	9	0	0	0	0	0	0	0	0	0	0	0	4.8	0	0	0	22.7	-	
0700	27	0	25	0	1	0	0	0	0	0	0	0	0	1	3.2	0	0.5	0	21.9	26.4	
0800	33	0	32	0	1	0	0	0	0	0	0	0	0	1	3.5	0	0.4	0	22.6	26.8	
0900	29	0	26	0	2	0	0	0	0	0	0	0	0	0	0.5	0	0	0	19	23.3	
1000	43	0	40	0	2	0	0	0	0	0	0	0	0	1	2	0	0.7	0	17	21.3	
1100	58	1	52	0	4	0	0	0	0	0	0	0	0	0	0.5	0	0.2	0	0	16.6	21.5
1200	57	0	52	0	5	0	0	0	0	0	0	0	0	1	2	0	0.5	0	16.8	21.5	
1300	56	0	52	0	3	0	0	0	0	0	0	0	0	1	1.5	0	0.3	0	17	22.1	
1400	52	1	48	0	3	0	0	0	0	0	0	0	0	1	1.1	0	0.3	0	17.3	22.1	
1500	59	0	53	0	4	0	1	0	0	0	0	0	0	0	0.5	0	0	0	0	17.2	21.9
1600	47	1	43	0	3	0	0	0	0	0	0	0	0	1	2.4	1	1.2	0	18	22.4	
1700	37	1	33	0	2	0	0	0	0	0	0	0	0	2	5.1	0	0.8	0	19.9	25.5	
1800	26	1	24	0	1	0	0	0	0	0	0	0	0	1	2.2	0	1.1	0	20.6	25.5	
1900	20	0	19	0	0	0	0	0	0	0	0	0	0	0	1.4	0	0	0	20.4	24.8	
2000	11	0	10	0	0	0	0	0	0	0	0	0	0	1	7.9	0	2.6	0	22.5	25.7	
2100	7	0	7	0	0	0	0	0	0	0	0	0	0	0	6.4	0	2.1	0	22.2	-	
2200	5	0	5	0	0	0	0	0	0	0	0	0	0	0	0	0	0	0	19.9	-	
2300	1	0	1	0	0	0	0	0	0	0	0	0	0	0	0	0	0	0	19.8	-	
07-19	523	5	480	2	31	2	3	0	0	0	0	0	0	10	1.9	2	0.5	0	0	18.2	23.5
06-22	570	6	525	2	31	2	3	0	0	0	0	0	0	12	2.1	3	0.5	0	0	18.4	23.7
06-00	575	6	531	2	31	2	3	0	0	0	0	0	0	12	2	3	0.5	0	0	18.5	23.7
00-00	581	6	536	2	32	2	3	0	0	0	0	0	0	12	2	3	0.5	0	0	18.5	23.7



Site 1
 Location Access Road, Att - Sign, OSGR: SP 46789 37517
 Direction Eastbound

8643 / Bodicote Business Park, Banbury
 September 2018
 Automatic Traffic Count

Virtual Week (1)

Time	Total	Classification												>PSL 30	>PSL% 30	>SL1 35 ACPO	>SL1% 35 ACPO	>SL2 45 DfT	>SL2% 45 DfT	Mean	Vpp 85
		1 MCL	2 SV	3 SVT	4 TB2	5 TB3	6 T4	7 ART3	8 ART4	9 ART5	10 ART6	11 BD	12 DRT								
Mon	537	5	490	4	34	2	1	0	0	0	1	0	0	14	2.6	2	0.4	0	0	19.1	24.4
Tue	518	8	459	3	43	3	2	0	0	0	0	0	0	14	2.7	3	0.6	0	0	18.4	23.9
Wed	671	5	623	2	38	1	1	0	1	0	0	0	0	10	1.5	1	0.1	0	0	18	23.3
Thu	623	7	568	0	38	4	5	0	1	0	0	0	0	12	1.9	3	0.5	0	0	18.9	24.2
Fri	733	9	673	2	39	3	7	0	0	0	0	0	0	14	1.9	5	0.7	0	0	18.4	23.5
Sat	657	8	614	2	28	0	2	0	0	0	2	0	1	12	1.8	5	0.8	0	0	18.3	23.5
Sun	329	1	322	1	5	0	0	0	0	0	0	0	0	6	1.8	1	0.3	0	0	18.5	24.2
5 Day Ave.	616	7	563	2	38	3	3	0	0	0	0	0	0	13	2.1	3	0.5	0	0.0	18.6	23.9
7 Day Ave.	581	6	536	2	32	2	3	0	0	0	0	0	0	12	2.0	3	0.5	0	0.0	18.5	23.7
--	4068	43	3749	14	225	13	18	0	2	0	3	0	1	82	2.0	20	0.5	0	0.0	18.5	23.7

Summary Graphs

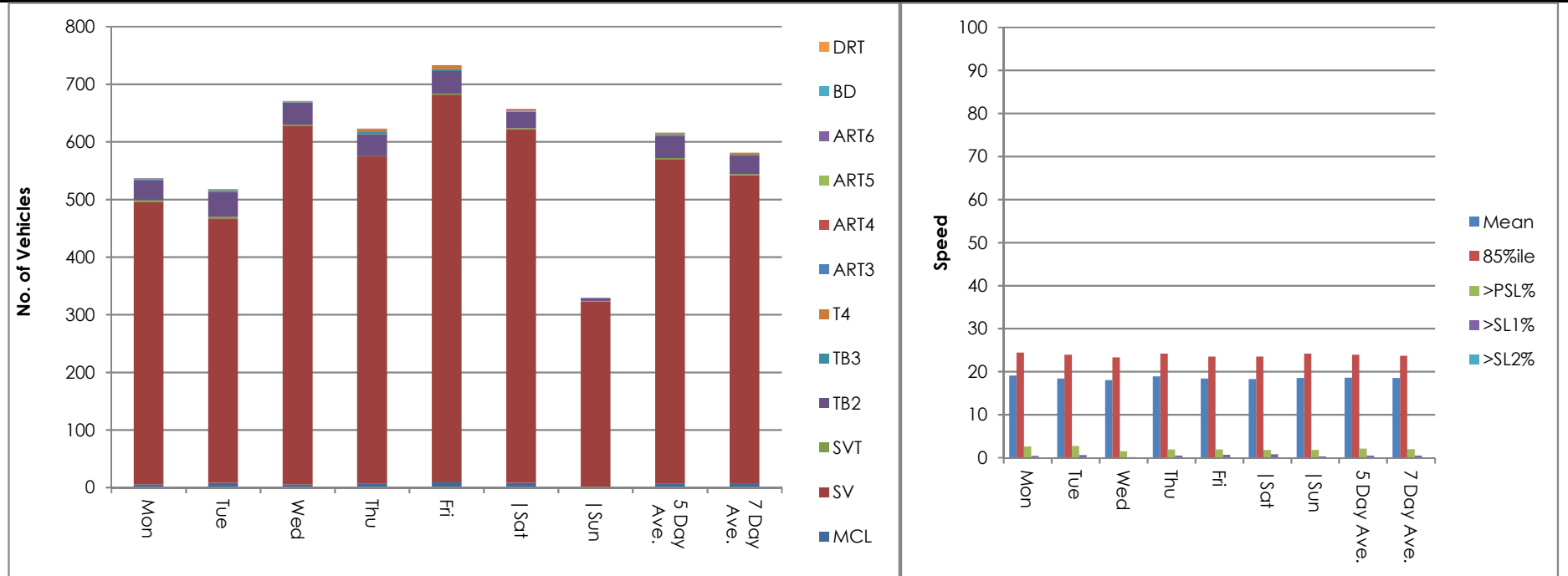

Site 1
 Location Access Road, Att - Sign, OSGR: SP 46789 37517
 Direction Eastbound

8643 / Bodicote Business Park, Banbury
 September 2018
 Automatic Traffic Count

26 September 2018

Time	Total	Speed Bins (mph)																										
		0 - 5	5 - 10	10 - 15	15 - 20	20 - 25	25 - 30	30 - 35	35 - 40	40 - 45	45 - 50	50 - 55	55 - 60	60 - 65	65 - 70	70 - 75	75 - 80	80 - 85	85 - 90	90 - 95	95 - 100	100 - 105	105 - 110	110 - 115	115 - 120	120 - 125	125 - 130	130 - 135
0000	0	0	0	0	0	0	0	0	0	0	0	0	0	0	0	0	0	0	0	0	0	0	0	0	0	0	0	0
0100	0	0	0	0	0	0	0	0	0	0	0	0	0	0	0	0	0	0	0	0	0	0	0	0	0	0	0	0
0200	0	0	0	0	0	0	0	0	0	0	0	0	0	0	0	0	0	0	0	0	0	0	0	0	0	0	0	0
0300	0	0	0	0	0	0	0	0	0	0	0	0	0	0	0	0	0	0	0	0	0	0	0	0	0	0	0	0
0400	1	0	0	0	0	1	0	0	0	0	0	0	0	0	0	0	0	0	0	0	0	0	0	0	0	0	0	0
0500	2	0	0	0	1	1	0	0	0	0	0	0	0	0	0	0	0	0	0	0	0	0	0	0	0	0	0	0
0600	14	0	0	2	2	6	3	1	0	0	0	0	0	0	0	0	0	0	0	0	0	0	0	0	0	0	0	0
0700	33	0	0	2	7	14	7	2	1	0	0	0	0	0	0	0	0	0	0	0	0	0	0	0	0	0	0	0
0800	34	0	0	3	5	16	10	0	0	0	0	0	0	0	0	0	0	0	0	0	0	0	0	0	0	0	0	0
0900	30	0	1	9	10	8	2	0	0	0	0	0	0	0	0	0	0	0	0	0	0	0	0	0	0	0	0	0
1000	37	0	3	5	22	5	2	0	0	0	0	0	0	0	0	0	0	0	0	0	0	0	0	0	0	0	0	0
1100	57	0	10	28	14	4	1	0	0	0	0	0	0	0	0	0	0	0	0	0	0	0	0	0	0	0	0	0
1200	73	0	10	25	25	9	2	2	0	0	0	0	0	0	0	0	0	0	0	0	0	0	0	0	0	0	0	0
1300	71	0	4	28	22	11	4	2	0	0	0	0	0	0	0	0	0	0	0	0	0	0	0	0	0	0	0	0
1400	63	0	0	19	26	15	3	0	0	0	0	0	0	0	0	0	0	0	0	0	0	0	0	0	0	0	0	0
1500	61	0	1	13	26	16	4	1	0	0	0	0	0	0	0	0	0	0	0	0	0	0	0	0	0	0	0	0
1600	54	0	1	16	21	13	3	0	0	0	0	0	0	0	0	0	0	0	0	0	0	0	0	0	0	0	0	0
1700	46	0	1	11	17	11	5	1	0	0	0	0	0	0	0	0	0	0	0	0	0	0	0	0	0	0	0	0
1800	45	0	3	6	12	20	4	0	0	0	0	0	0	0	0	0	0	0	0	0	0	0	0	0	0	0	0	0
1900	29	0	1	3	10	14	1	0	0	0	0	0	0	0	0	0	0	0	0	0	0	0	0	0	0	0	0	0
2000	15	0	0	0	2	9	4	0	0	0	0	0	0	0	0	0	0	0	0	0	0	0	0	0	0	0	0	0
2100	2	0	0	0	0	1	1	0	0	0	0	0	0	0	0	0	0	0	0	0	0	0	0	0	0	0	0	0
2200	4	0	0	1	1	2	0	0	0	0	0	0	0	0	0	0	0	0	0	0	0	0	0	0	0	0	0	0
2300	0	0	0	0	0	0	0	0	0	0	0	0	0	0	0	0	0	0	0	0	0	0	0	0	0	0	0	0
07-19	604	0	34	165	207	142	47	8	1	0	0	0	0	0	0	0	0	0	0	0	0	0	0	0	0	0	0	0
06-22	664	0	35	170	221	172	56	9	1	0	0	0	0	0	0	0	0	0	0	0	0	0	0	0	0	0	0	0
06-00	668	0	35	171	222	174	56	9	1	0	0	0	0	0	0	0	0	0	0	0	0	0	0	0	0	0	0	0
00-00	671	0	35	171	223	176	56	9	1	0	0	0	0	0	0	0	0	0	0	0	0	0	0	0	0	0	0	0



Site 1
 Location Access Road, Att - Sign, OSGR: SP 46789 37517
 Direction Eastbound

8643 / Bodicote Business Park, Banbury
 September 2018
 Automatic Traffic Count

27 September 2018

Time	Total	Speed Bins (mph)																										
		0 - 5	5 - 10	10 - 15	15 - 20	20 - 25	25 - 30	30 - 35	35 - 40	40 - 45	45 - 50	50 - 55	55 - 60	60 - 65	65 - 70	70 - 75	75 - 80	80 - 85	85 - 90	90 - 95	95 - 100	100 - 105	105 - 110	110 - 115	115 - 120	120 - 125	125 - 130	130 - 135
0000	0	0	0	0	0	0	0	0	0	0	0	0	0	0	0	0	0	0	0	0	0	0	0	0	0	0	0	0
0100	0	0	0	0	0	0	0	0	0	0	0	0	0	0	0	0	0	0	0	0	0	0	0	0	0	0	0	0
0200	0	0	0	0	0	0	0	0	0	0	0	0	0	0	0	0	0	0	0	0	0	0	0	0	0	0	0	0
0300	0	0	0	0	0	0	0	0	0	0	0	0	0	0	0	0	0	0	0	0	0	0	0	0	0	0	0	0
0400	1	0	0	0	0	1	0	0	0	0	0	0	0	0	0	0	0	0	0	0	0	0	0	0	0	0	0	0
0500	1	0	0	0	1	0	0	0	0	0	0	0	0	0	0	0	0	0	0	0	0	0	0	0	0	0	0	0
0600	12	0	1	0	2	3	6	0	0	0	0	0	0	0	0	0	0	0	0	0	0	0	0	0	0	0	0	0
0700	34	0	0	2	8	15	9	0	0	0	0	0	0	0	0	0	0	0	0	0	0	0	0	0	0	0	0	0
0800	37	0	2	0	5	17	10	3	0	0	0	0	0	0	0	0	0	0	0	0	0	0	0	0	0	0	0	0
0900	33	0	1	3	13	12	4	0	0	0	0	0	0	0	0	0	0	0	0	0	0	0	0	0	0	0	0	0
1000	38	0	1	10	21	4	1	1	0	0	0	0	0	0	0	0	0	0	0	0	0	0	0	0	0	0	0	0
1100	45	0	0	9	24	11	1	0	0	0	0	0	0	0	0	0	0	0	0	0	0	0	0	0	0	0	0	0
1200	70	0	5	19	26	17	1	1	1	0	0	0	0	0	0	0	0	0	0	0	0	0	0	0	0	0	0	0
1300	56	0	3	19	20	9	5	0	0	0	0	0	0	0	0	0	0	0	0	0	0	0	0	0	0	0	0	0
1400	66	0	1	14	31	15	5	0	0	0	0	0	0	0	0	0	0	0	0	0	0	0	0	0	0	0	0	0
1500	82	0	7	23	32	17	3	0	0	0	0	0	0	0	0	0	0	0	0	0	0	0	0	0	0	0	0	0
1600	51	0	1	10	21	13	4	2	0	0	0	0	0	0	0	0	0	0	0	0	0	0	0	0	0	0	0	0
1700	39	0	2	6	16	10	4	0	1	0	0	0	0	0	0	0	0	0	0	0	0	0	0	0	0	0	0	0
1800	21	0	0	1	5	9	6	0	0	0	0	0	0	0	0	0	0	0	0	0	0	0	0	0	0	0	0	0
1900	18	0	0	1	5	8	4	0	0	0	0	0	0	0	0	0	0	0	0	0	0	0	0	0	0	0	0	0
2000	10	0	0	0	0	6	2	1	1	0	0	0	0	0	0	0	0	0	0	0	0	0	0	0	0	0	0	0
2100	4	0	0	0	1	1	1	1	0	0	0	0	0	0	0	0	0	0	0	0	0	0	0	0	0	0	0	0
2200	4	0	0	0	3	1	0	0	0	0	0	0	0	0	0	0	0	0	0	0	0	0	0	0	0	0	0	0
2300	1	0	0	0	1	0	0	0	0	0	0	0	0	0	0	0	0	0	0	0	0	0	0	0	0	0	0	0
07-19	572	0	23	116	222	149	53	7	2	0	0	0	0	0	0	0	0	0	0	0	0	0	0	0	0	0	0	0
06-22	616	0	24	117	230	167	66	9	3	0	0	0	0	0	0	0	0	0	0	0	0	0	0	0	0	0	0	0
06-00	621	0	24	117	234	168	66	9	3	0	0	0	0	0	0	0	0	0	0	0	0	0	0	0	0	0	0	0
00-00	623	0	24	117	235	169	66	9	3	0	0	0	0	0	0	0	0	0	0	0	0	0	0	0	0	0	0	0



Site 1
 Location Access Road, Att - Sign, OSGR: SP 46789 37517
 Direction Eastbound

8643 / Bodicote Business Park, Banbury
 September 2018
 Automatic Traffic Count

28 September 2018

Time	Total	Speed Bins (mph)																										
		0 - 5	5 - 10	10 - 15	15 - 20	20 - 25	25 - 30	30 - 35	35 - 40	40 - 45	45 - 50	50 - 55	55 - 60	60 - 65	65 - 70	70 - 75	75 - 80	80 - 85	85 - 90	90 - 95	95 - 100	100 - 105	105 - 110	110 - 115	115 - 120	120 - 125	125 - 130	130 - 135
0000	0	0	0	0	0	0	0	0	0	0	0	0	0	0	0	0	0	0	0	0	0	0	0	0	0	0	0	0
0100	1	0	0	0	0	1	0	0	0	0	0	0	0	0	0	0	0	0	0	0	0	0	0	0	0	0	0	0
0200	1	0	0	0	1	0	0	0	0	0	0	0	0	0	0	0	0	0	0	0	0	0	0	0	0	0	0	0
0300	0	0	0	0	0	0	0	0	0	0	0	0	0	0	0	0	0	0	0	0	0	0	0	0	0	0	0	0
0400	2	0	0	0	0	0	2	0	0	0	0	0	0	0	0	0	0	0	0	0	0	0	0	0	0	0	0	0
0500	5	0	0	1	1	3	0	0	0	0	0	0	0	0	0	0	0	0	0	0	0	0	0	0	0	0	0	0
0600	11	0	0	0	4	5	1	1	0	0	0	0	0	0	0	0	0	0	0	0	0	0	0	0	0	0	0	0
0700	40	0	1	1	10	18	8	2	0	0	0	0	0	0	0	0	0	0	0	0	0	0	0	0	0	0	0	0
0800	49	0	0	4	9	25	10	0	1	0	0	0	0	0	0	0	0	0	0	0	0	0	0	0	0	0	0	0
0900	39	0	1	8	18	9	3	0	0	0	0	0	0	0	0	0	0	0	0	0	0	0	0	0	0	0	0	0
1000	50	0	3	20	20	7	0	0	0	0	0	0	0	0	0	0	0	0	0	0	0	0	0	0	0	0	0	0
1100	78	0	0	29	38	8	2	0	1	0	0	0	0	0	0	0	0	0	0	0	0	0	0	0	0	0	0	0
1200	63	1	2	12	30	10	5	2	1	0	0	0	0	0	0	0	0	0	0	0	0	0	0	0	0	0	0	0
1300	68	0	1	28	23	12	4	0	0	0	0	0	0	0	0	0	0	0	0	0	0	0	0	0	0	0	0	0
1400	51	0	4	12	22	11	1	1	0	0	0	0	0	0	0	0	0	0	0	0	0	0	0	0	0	0	0	0
1500	76	0	3	20	26	23	4	0	0	0	0	0	0	0	0	0	0	0	0	0	0	0	0	0	0	0	0	0
1600	74	0	2	22	37	9	3	0	1	0	0	0	0	0	0	0	0	0	0	0	0	0	0	0	0	0	0	0
1700	51	0	1	8	21	11	8	2	0	0	0	0	0	0	0	0	0	0	0	0	0	0	0	0	0	0	0	0
1800	19	0	0	5	4	8	1	0	1	0	0	0	0	0	0	0	0	0	0	0	0	0	0	0	0	0	0	0
1900	18	0	0	3	4	9	1	1	0	0	0	0	0	0	0	0	0	0	0	0	0	0	0	0	0	0	0	0
2000	13	0	0	2	3	7	1	0	0	0	0	0	0	0	0	0	0	0	0	0	0	0	0	0	0	0	0	0
2100	8	0	0	1	4	0	3	0	0	0	0	0	0	0	0	0	0	0	0	0	0	0	0	0	0	0	0	0
2200	13	0	0	1	7	4	1	0	0	0	0	0	0	0	0	0	0	0	0	0	0	0	0	0	0	0	0	0
2300	3	0	0	0	2	0	1	0	0	0	0	0	0	0	0	0	0	0	0	0	0	0	0	0	0	0	0	0
07-19	658	1	18	169	258	151	49	7	5	0	0	0	0	0	0	0	0	0	0	0	0	0	0	0	0	0	0	0
06-22	708	1	18	175	273	172	55	9	5	0	0	0	0	0	0	0	0	0	0	0	0	0	0	0	0	0	0	0
06-00	724	1	18	176	282	176	57	9	5	0	0	0	0	0	0	0	0	0	0	0	0	0	0	0	0	0	0	0
00-00	733	1	18	177	284	180	59	9	5	0	0	0	0	0	0	0	0	0	0	0	0	0	0	0	0	0	0	0



Site 1
 Location Access Road, Att - Sign, OSGR: SP 46789 37517
 Direction Eastbound

8643 / Bodicote Business Park, Banbury
 September 2018
 Automatic Traffic Count

29 September 2018

Time	Total	Speed Bins (mph)																										
		0 - 5	5 - 10	10 - 15	15 - 20	20 - 25	25 - 30	30 - 35	35 - 40	40 - 45	45 - 50	50 - 55	55 - 60	60 - 65	65 - 70	70 - 75	75 - 80	80 - 85	85 - 90	90 - 95	95 - 100	100 - 105	105 - 110	110 - 115	115 - 120	120 - 125	125 - 130	130 - 135
0000	2	0	0	0	2	0	0	0	0	0	0	0	0	0	0	0	0	0	0	0	0	0	0	0	0	0	0	0
0100	1	0	0	1	0	0	0	0	0	0	0	0	0	0	0	0	0	0	0	0	0	0	0	0	0	0	0	0
0200	1	0	0	0	1	0	0	0	0	0	0	0	0	0	0	0	0	0	0	0	0	0	0	0	0	0	0	0
0300	1	0	0	0	1	0	0	0	0	0	0	0	0	0	0	0	0	0	0	0	0	0	0	0	0	0	0	0
0400	2	0	0	0	1	1	0	0	0	0	0	0	0	0	0	0	0	0	0	0	0	0	0	0	0	0	0	0
0500	1	0	0	0	0	1	0	0	0	0	0	0	0	0	0	0	0	0	0	0	0	0	0	0	0	0	0	0
0600	4	0	0	0	1	3	0	0	0	0	0	0	0	0	0	0	0	0	0	0	0	0	0	0	0	0	0	0
0700	7	0	0	0	2	4	1	0	0	0	0	0	0	0	0	0	0	0	0	0	0	0	0	0	0	0	0	0
0800	26	0	0	2	3	13	8	0	0	0	0	0	0	0	0	0	0	0	0	0	0	0	0	0	0	0	0	0
0900	33	0	1	1	14	13	4	0	0	0	0	0	0	0	0	0	0	0	0	0	0	0	0	0	0	0	0	0
1000	53	0	1	16	22	7	4	3	0	0	0	0	0	0	0	0	0	0	0	0	0	0	0	0	0	0	0	0
1100	79	0	4	26	23	18	7	1	0	0	0	0	0	0	0	0	0	0	0	0	0	0	0	0	0	0	0	0
1200	66	0	7	25	17	14	3	0	0	0	0	0	0	0	0	0	0	0	0	0	0	0	0	0	0	0	0	0
1300	57	0	1	21	23	9	2	1	0	0	0	0	0	0	0	0	0	0	0	0	0	0	0	0	0	0	0	0
1400	60	0	1	28	16	10	4	1	0	0	0	0	0	0	0	0	0	0	0	0	0	0	0	0	0	0	0	0
1500	56	0	0	23	18	14	0	1	0	0	0	0	0	0	0	0	0	0	0	0	0	0	0	0	0	0	0	0
1600	53	0	4	14	19	11	3	0	2	0	0	0	0	0	0	0	0	0	0	0	0	0	0	0	0	0	0	0
1700	43	0	2	6	15	15	5	0	0	0	0	0	0	0	0	0	0	0	0	0	0	0	0	0	0	0	0	0
1800	39	0	0	4	19	12	3	0	1	0	0	0	0	0	0	0	0	0	0	0	0	0	0	0	0	0	0	0
1900	36	0	0	4	15	12	5	0	0	0	0	0	0	0	0	0	0	0	0	0	0	0	0	0	0	0	0	0
2000	15	0	0	0	2	11	1	0	1	0	0	0	0	0	0	0	0	0	0	0	0	0	0	0	0	0	0	0
2100	12	0	0	0	6	4	1	0	1	0	0	0	0	0	0	0	0	0	0	0	0	0	0	0	0	0	0	0
2200	7	0	0	0	2	4	1	0	0	0	0	0	0	0	0	0	0	0	0	0	0	0	0	0	0	0	0	0
2300	3	0	0	1	0	2	0	0	0	0	0	0	0	0	0	0	0	0	0	0	0	0	0	0	0	0	0	0
07-19	572	0	21	166	191	140	44	7	3	0	0	0	0	0	0	0	0	0	0	0	0	0	0	0	0	0	0	0
06-22	639	0	21	170	215	170	51	7	5	0	0	0	0	0	0	0	0	0	0	0	0	0	0	0	0	0	0	0
06-00	649	0	21	171	217	176	52	7	5	0	0	0	0	0	0	0	0	0	0	0	0	0	0	0	0	0	0	0
00-00	657	0	21	172	222	178	52	7	5	0	0	0	0	0	0	0	0	0	0	0	0	0	0	0	0	0	0	0



Site 1
 Location Access Road, Att - Sign, OSGR: SP 46789 37517
 Direction Eastbound

8643 / Bodicote Business Park, Banbury
 September 2018
 Automatic Traffic Count

30 September 2018

Time	Total	Speed Bins (mph)																										
		0 - 5	5 - 10	10 - 15	15 - 20	20 - 25	25 - 30	30 - 35	35 - 40	40 - 45	45 - 50	50 - 55	55 - 60	60 - 65	65 - 70	70 - 75	75 - 80	80 - 85	85 - 90	90 - 95	95 - 100	100 - 105	105 - 110	110 - 115	115 - 120	120 - 125	125 - 130	130 - 135
0000	2	0	0	0	0	2	0	0	0	0	0	0	0	0	0	0	0	0	0	0	0	0	0	0	0	0	0	0
0100	2	0	0	0	0	1	1	0	0	0	0	0	0	0	0	0	0	0	0	0	0	0	0	0	0	0	0	0
0200	1	0	0	0	0	1	0	0	0	0	0	0	0	0	0	0	0	0	0	0	0	0	0	0	0	0	0	0
0300	0	0	0	0	0	0	0	0	0	0	0	0	0	0	0	0	0	0	0	0	0	0	0	0	0	0	0	0
0400	2	0	0	0	0	2	0	0	0	0	0	0	0	0	0	0	0	0	0	0	0	0	0	0	0	0	0	0
0500	1	0	0	0	0	1	0	0	0	0	0	0	0	0	0	0	0	0	0	0	0	0	0	0	0	0	0	0
0600	1	0	0	0	0	1	0	0	0	0	0	0	0	0	0	0	0	0	0	0	0	0	0	0	0	0	0	0
0700	2	0	0	0	1	1	0	0	0	0	0	0	0	0	0	0	0	0	0	0	0	0	0	0	0	0	0	0
0800	6	0	0	1	1	2	2	0	0	0	0	0	0	0	0	0	0	0	0	0	0	0	0	0	0	0	0	0
0900	17	0	0	1	5	9	2	0	0	0	0	0	0	0	0	0	0	0	0	0	0	0	0	0	0	0	0	0
1000	35	0	3	12	10	9	1	0	0	0	0	0	0	0	0	0	0	0	0	0	0	0	0	0	0	0	0	0
1100	43	0	2	14	12	10	5	0	0	0	0	0	0	0	0	0	0	0	0	0	0	0	0	0	0	0	0	0
1200	42	0	3	18	12	8	1	0	0	0	0	0	0	0	0	0	0	0	0	0	0	0	0	0	0	0	0	0
1300	41	0	0	18	10	11	1	1	0	0	0	0	0	0	0	0	0	0	0	0	0	0	0	0	0	0	0	0
1400	35	0	3	9	13	8	0	1	1	0	0	0	0	0	0	0	0	0	0	0	0	0	0	0	0	0	0	0
1500	27	0	4	8	8	3	4	0	0	0	0	0	0	0	0	0	0	0	0	0	0	0	0	0	0	0	0	0
1600	14	0	0	2	7	3	2	0	0	0	0	0	0	0	0	0	0	0	0	0	0	0	0	0	0	0	0	0
1700	20	0	1	0	6	8	4	1	0	0	0	0	0	0	0	0	0	0	0	0	0	0	0	0	0	0	0	0
1800	12	0	0	1	6	2	3	0	0	0	0	0	0	0	0	0	0	0	0	0	0	0	0	0	0	0	0	0
1900	7	0	0	0	2	4	1	0	0	0	0	0	0	0	0	0	0	0	0	0	0	0	0	0	0	0	0	0
2000	9	0	0	1	1	5	0	2	0	0	0	0	0	0	0	0	0	0	0	0	0	0	0	0	0	0	0	0
2100	8	0	0	2	2	0	4	0	0	0	0	0	0	0	0	0	0	0	0	0	0	0	0	0	0	0	0	0
2200	2	0	1	0	0	1	0	0	0	0	0	0	0	0	0	0	0	0	0	0	0	0	0	0	0	0	0	0
2300	0	0	0	0	0	0	0	0	0	0	0	0	0	0	0	0	0	0	0	0	0	0	0	0	0	0	0	0
07-19	294	0	16	84	91	74	25	3	1	0	0	0	0	0	0	0	0	0	0	0	0	0	0	0	0	0	0	0
06-22	319	0	16	87	96	84	30	5	1	0	0	0	0	0	0	0	0	0	0	0	0	0	0	0	0	0	0	0
06-00	321	0	17	87	96	85	30	5	1	0	0	0	0	0	0	0	0	0	0	0	0	0	0	0	0	0	0	0
00-00	329	0	17	87	96	92	31	5	1	0	0	0	0	0	0	0	0	0	0	0	0	0	0	0	0	0	0	0



Site 1
 Location Access Road, Att - Sign, OSGR: SP 46789 37517
 Direction Eastbound

8643 / Bodicote Business Park, Banbury
 September 2018
 Automatic Traffic Count

01 October 2018

Time	Total	Speed Bins (mph)																										
		0 - 5	5 - 10	10 - 15	15 - 20	20 - 25	25 - 30	30 - 35	35 - 40	40 - 45	45 - 50	50 - 55	55 - 60	60 - 65	65 - 70	70 - 75	75 - 80	80 - 85	85 - 90	90 - 95	95 - 100	100 - 105	105 - 110	110 - 115	115 - 120	120 - 125	125 - 130	130 - 135
0000	1	0	0	0	0	1	0	0	0	0	0	0	0	0	0	0	0	0	0	0	0	0	0	0	0	0	0	0
0100	0	0	0	0	0	0	0	0	0	0	0	0	0	0	0	0	0	0	0	0	0	0	0	0	0	0	0	0
0200	0	0	0	0	0	0	0	0	0	0	0	0	0	0	0	0	0	0	0	0	0	0	0	0	0	0	0	0
0300	1	0	0	0	0	1	0	0	0	0	0	0	0	0	0	0	0	0	0	0	0	0	0	0	0	0	0	0
0400	2	0	0	0	0	2	0	0	0	0	0	0	0	0	0	0	0	0	0	0	0	0	0	0	0	0	0	0
0500	2	0	0	0	0	1	1	0	0	0	0	0	0	0	0	0	0	0	0	0	0	0	0	0	0	0	0	0
0600	11	0	0	0	1	8	1	1	0	0	0	0	0	0	0	0	0	0	0	0	0	0	0	0	0	0	0	0
0700	39	0	0	2	17	13	7	0	0	0	0	0	0	0	0	0	0	0	0	0	0	0	0	0	0	0	0	0
0800	36	0	0	0	7	14	13	2	0	0	0	0	0	0	0	0	0	0	0	0	0	0	0	0	0	0	0	0
0900	24	0	0	3	6	10	4	1	0	0	0	0	0	0	0	0	0	0	0	0	0	0	0	0	0	0	0	0
1000	48	0	1	13	18	9	6	0	1	0	0	0	0	0	0	0	0	0	0	0	0	0	0	0	0	0	0	0
1100	54	0	1	22	19	11	1	0	0	0	0	0	0	0	0	0	0	0	0	0	0	0	0	0	0	0	0	0
1200	45	0	3	10	25	7	0	0	0	0	0	0	0	0	0	0	0	0	0	0	0	0	0	0	0	0	0	0
1300	49	0	2	17	17	10	3	0	0	0	0	0	0	0	0	0	0	0	0	0	0	0	0	0	0	0	0	0
1400	41	0	3	9	19	7	3	0	0	0	0	0	0	0	0	0	0	0	0	0	0	0	0	0	0	0	0	0
1500	56	0	4	15	25	8	4	0	0	0	0	0	0	0	0	0	0	0	0	0	0	0	0	0	0	0	0	0
1600	40	0	1	4	18	11	3	2	1	0	0	0	0	0	0	0	0	0	0	0	0	0	0	0	0	0	0	0
1700	34	0	0	5	17	6	2	4	0	0	0	0	0	0	0	0	0	0	0	0	0	0	0	0	0	0	0	0
1800	24	0	1	1	9	9	3	1	0	0	0	0	0	0	0	0	0	0	0	0	0	0	0	0	0	0	0	0
1900	18	0	0	1	2	10	4	1	0	0	0	0	0	0	0	0	0	0	0	0	0	0	0	0	0	0	0	0
2000	5	0	0	1	2	2	0	0	0	0	0	0	0	0	0	0	0	0	0	0	0	0	0	0	0	0	0	0
2100	6	0	0	0	1	5	0	0	0	0	0	0	0	0	0	0	0	0	0	0	0	0	0	0	0	0	0	0
2200	1	0	0	0	0	1	0	0	0	0	0	0	0	0	0	0	0	0	0	0	0	0	0	0	0	0	0	0
2300	0	0	0	0	0	0	0	0	0	0	0	0	0	0	0	0	0	0	0	0	0	0	0	0	0	0	0	0
07-19	490	0	16	101	197	115	49	10	2	0	0	0	0	0	0	0	0	0	0	0	0	0	0	0	0	0	0	0
06-22	530	0	16	103	203	140	54	12	2	0	0	0	0	0	0	0	0	0	0	0	0	0	0	0	0	0	0	0
06-00	531	0	16	103	203	141	54	12	2	0	0	0	0	0	0	0	0	0	0	0	0	0	0	0	0	0	0	0
00-00	537	0	16	103	203	146	55	12	2	0	0	0	0	0	0	0	0	0	0	0	0	0	0	0	0	0	0	0



Site 1
 Location Access Road, Att - Sign, OSGR: SP 46789 37517
 Direction Eastbound

8643 / Bodicote Business Park, Banbury
 September 2018
 Automatic Traffic Count

02 October 2018

Time	Total	Speed Bins (mph)																										
		0 - 5	5 - 10	10 - 15	15 - 20	20 - 25	25 - 30	30 - 35	35 - 40	40 - 45	45 - 50	50 - 55	55 - 60	60 - 65	65 - 70	70 - 75	75 - 80	80 - 85	85 - 90	90 - 95	95 - 100	100 - 105	105 - 110	110 - 115	115 - 120	120 - 125	125 - 130	130 - 135
0000	1	0	0	0	1	0	0	0	0	0	0	0	0	0	0	0	0	0	0	0	0	0	0	0	0	0	0	0
0100	0	0	0	0	0	0	0	0	0	0	0	0	0	0	0	0	0	0	0	0	0	0	0	0	0	0	0	0
0200	0	0	0	0	0	0	0	0	0	0	0	0	0	0	0	0	0	0	0	0	0	0	0	0	0	0	0	0
0300	0	0	0	0	0	0	0	0	0	0	0	0	0	0	0	0	0	0	0	0	0	0	0	0	0	0	0	0
0400	2	0	0	0	1	0	1	0	0	0	0	0	0	0	0	0	0	0	0	0	0	0	0	0	0	0	0	0
0500	1	0	0	0	0	1	0	0	0	0	0	0	0	0	0	0	0	0	0	0	0	0	0	0	0	0	0	0
0600	10	0	0	1	1	5	3	0	0	0	0	0	0	0	0	0	0	0	0	0	0	0	0	0	0	0	0	0
0700	33	0	0	2	12	15	3	1	0	0	0	0	0	0	0	0	0	0	0	0	0	0	0	0	0	0	0	0
0800	43	0	0	3	9	20	9	2	0	0	0	0	0	0	0	0	0	0	0	0	0	0	0	0	0	0	0	0
0900	24	0	0	7	13	3	1	0	0	0	0	0	0	0	0	0	0	0	0	0	0	0	0	0	0	0	0	0
1000	40	0	4	16	14	4	1	0	1	0	0	0	0	0	0	0	0	0	0	0	0	0	0	0	0	0	0	0
1100	50	0	4	12	22	9	3	0	0	0	0	0	0	0	0	0	0	0	0	0	0	0	0	0	0	0	0	0
1200	42	0	2	9	20	8	2	1	0	0	0	0	0	0	0	0	0	0	0	0	0	0	0	0	0	0	0	0
1300	49	0	1	15	22	6	3	1	1	0	0	0	0	0	0	0	0	0	0	0	0	0	0	0	0	0	0	0
1400	48	0	2	17	24	5	0	0	0	0	0	0	0	0	0	0	0	0	0	0	0	0	0	0	0	0	0	0
1500	53	0	5	21	16	7	4	0	0	0	0	0	0	0	0	0	0	0	0	0	0	0	0	0	0	0	0	0
1600	46	0	2	15	18	10	1	0	0	0	0	0	0	0	0	0	0	0	0	0	0	0	0	0	0	0	0	0
1700	23	0	0	2	5	10	2	3	1	0	0	0	0	0	0	0	0	0	0	0	0	0	0	0	0	0	0	0
1800	19	0	0	0	7	6	5	1	0	0	0	0	0	0	0	0	0	0	0	0	0	0	0	0	0	0	0	0
1900	15	0	0	3	5	5	2	0	0	0	0	0	0	0	0	0	0	0	0	0	0	0	0	0	0	0	0	0
2000	9	0	0	0	2	6	0	1	0	0	0	0	0	0	0	0	0	0	0	0	0	0	0	0	0	0	0	0
2100	7	0	0	1	1	3	1	1	0	0	0	0	0	0	0	0	0	0	0	0	0	0	0	0	0	0	0	0
2200	3	0	0	1	1	1	0	0	0	0	0	0	0	0	0	0	0	0	0	0	0	0	0	0	0	0	0	0
2300	0	0	0	0	0	0	0	0	0	0	0	0	0	0	0	0	0	0	0	0	0	0	0	0	0	0	0	0
07-19	470	0	20	119	182	103	34	9	3	0	0	0	0	0	0	0	0	0	0	0	0	0	0	0	0	0	0	0
06-22	511	0	20	124	191	122	40	11	3	0	0	0	0	0	0	0	0	0	0	0	0	0	0	0	0	0	0	0
06-00	514	0	20	125	192	123	40	11	3	0	0	0	0	0	0	0	0	0	0	0	0	0	0	0	0	0	0	0
00-00	518	0	20	125	194	124	41	11	3	0	0	0	0	0	0	0	0	0	0	0	0	0	0	0	0	0	0	0



Site 1
 Location Access Road, Att - Sign, OSGR: SP 46789 37517
 Direction Eastbound

8643 / Bodicote Business Park, Banbury
 September 2018
 Automatic Traffic Count

Virtual Day (7)

Time	Total	Speed Bins (mph)																											
		0 - 5	5 - 10	10 - 15	15 - 20	20 - 25	25 - 30	30 - 35	35 - 40	40 - 45	45 - 50	50 - 55	55 - 60	60 - 65	65 - 70	70 - 75	75 - 80	80 - 85	85 - 90	90 - 95	95 - 100	100 - 105	105 - 110	110 - 115	115 - 120	120 - 125	125 - 130	130 - 135	135 - 140
0000	1	0	0	0	0	0	0	0	0	0	0	0	0	0	0	0	0	0	0	0	0	0	0	0	0	0	0	0	
0100	1	0	0	0	0	0	0	0	0	0	0	0	0	0	0	0	0	0	0	0	0	0	0	0	0	0	0	0	0
0200	0	0	0	0	0	0	0	0	0	0	0	0	0	0	0	0	0	0	0	0	0	0	0	0	0	0	0	0	0
0300	0	0	0	0	0	0	0	0	0	0	0	0	0	0	0	0	0	0	0	0	0	0	0	0	0	0	0	0	0
0400	2	0	0	0	0	1	0	0	0	0	0	0	0	0	0	0	0	0	0	0	0	0	0	0	0	0	0	0	0
0500	2	0	0	0	0	1	0	0	0	0	0	0	0	0	0	0	0	0	0	0	0	0	0	0	0	0	0	0	0
0600	9	0	0	0	2	4	2	0	0	0	0	0	0	0	0	0	0	0	0	0	0	0	0	0	0	0	0	0	0
0700	27	0	0	1	8	11	5	1	0	0	0	0	0	0	0	0	0	0	0	0	0	0	0	0	0	0	0	0	0
0800	33	0	0	2	6	15	9	1	0	0	0	0	0	0	0	0	0	0	0	0	0	0	0	0	0	0	0	0	0
0900	29	0	1	5	11	9	3	0	0	0	0	0	0	0	0	0	0	0	0	0	0	0	0	0	0	0	0	0	0
1000	43	0	2	13	18	6	2	1	0	0	0	0	0	0	0	0	0	0	0	0	0	0	0	0	0	0	0	0	0
1100	58	0	3	20	22	10	3	0	0	0	0	0	0	0	0	0	0	0	0	0	0	0	0	0	0	0	0	0	0
1200	57	0	5	17	22	10	2	1	0	0	0	0	0	0	0	0	0	0	0	0	0	0	0	0	0	0	0	0	0
1300	56	0	2	21	20	10	3	1	0	0	0	0	0	0	0	0	0	0	0	0	0	0	0	0	0	0	0	0	0
1400	52	0	2	15	22	10	2	0	0	0	0	0	0	0	0	0	0	0	0	0	0	0	0	0	0	0	0	0	0
1500	59	0	3	18	22	13	3	0	0	0	0	0	0	0	0	0	0	0	0	0	0	0	0	0	0	0	0	0	0
1600	47	0	2	12	20	10	3	1	1	0	0	0	0	0	0	0	0	0	0	0	0	0	0	0	0	0	0	0	0
1700	37	0	1	5	14	10	4	2	0	0	0	0	0	0	0	0	0	0	0	0	0	0	0	0	0	0	0	0	0
1800	26	0	1	3	9	9	4	0	0	0	0	0	0	0	0	0	0	0	0	0	0	0	0	0	0	0	0	0	0
1900	20	0	0	2	6	9	3	0	0	0	0	0	0	0	0	0	0	0	0	0	0	0	0	0	0	0	0	0	0
2000	11	0	0	1	2	7	1	1	0	0	0	0	0	0	0	0	0	0	0	0	0	0	0	0	0	0	0	0	0
2100	7	0	0	1	2	2	2	0	0	0	0	0	0	0	0	0	0	0	0	0	0	0	0	0	0	0	0	0	0
2200	5	0	0	0	2	2	0	0	0	0	0	0	0	0	0	0	0	0	0	0	0	0	0	0	0	0	0	0	0
2300	1	0	0	0	0	0	0	0	0	0	0	0	0	0	0	0	0	0	0	0	0	0	0	0	0	0	0	0	0
07-19	523	0	21	131	193	125	43	7	2	0	0	0	0	0	0	0	0	0	0	0	0	0	0	0	0	0	0	0	0
06-22	570	0	21	135	204	147	50	9	3	0	0	0	0	0	0	0	0	0	0	0	0	0	0	0	0	0	0	0	0
06-00	575	0	22	136	207	149	51	9	3	0	0	0	0	0	0	0	0	0	0	0	0	0	0	0	0	0	0	0	0
00-00	581	0	22	136	208	152	51	9	3	0	0	0	0	0	0	0	0	0	0	0	0	0	0	0	0	0	0	0	0



Site 1
 Location Access Road, Att - Sign, OSGR: SP 46789 37517
 Direction Eastbound

8643 / Bodicote Business Park, Banbury
 September 2018
 Automatic Traffic Count

Virtual Week (1)

Time	Total	Speed Bins (mph)																											
		0 - 5	5 - 10	10 - 15	15 - 20	20 - 25	25 - 30	30 - 35	35 - 40	40 - 45	45 - 50	50 - 55	55 - 60	60 - 65	65 - 70	70 - 75	75 - 80	80 - 85	85 - 90	90 - 95	95 - 100	100 - 105	105 - 110	110 - 115	115 - 120	120 - 125	125 - 130	130 - 135	135 - 140
Mon	537	0	16	103	203	146	55	12	2	0	0	0	0	0	0	0	0	0	0	0	0	0	0	0	0	0	0	0	0
Tue	518	0	20	125	194	124	41	11	3	0	0	0	0	0	0	0	0	0	0	0	0	0	0	0	0	0	0	0	0
Wed	671	0	35	171	223	176	56	9	1	0	0	0	0	0	0	0	0	0	0	0	0	0	0	0	0	0	0	0	0
Thu	623	0	24	117	235	169	66	9	3	0	0	0	0	0	0	0	0	0	0	0	0	0	0	0	0	0	0	0	0
Fri	733	1	18	177	284	180	59	9	5	0	0	0	0	0	0	0	0	0	0	0	0	0	0	0	0	0	0	0	0
Sat	657	0	21	172	222	178	52	7	5	0	0	0	0	0	0	0	0	0	0	0	0	0	0	0	0	0	0	0	0
Sun	329	0	17	87	96	92	31	5	1	0	0	0	0	0	0	0	0	0	0	0	0	0	0	0	0	0	0	0	0
5 Day Ave.	616	0	23	139	228	159	55	10	3	0	0	0	0	0	0	0	0	0	0	0	0	0	0	0	0	0	0	0	0
7 Day Ave.	581	0	22	136	208	152	51	9	3	0	0	0	0	0	0	0	0	0	0	0	0	0	0	0	0	0	0	0	0
--	4068	1	151	952	1457	1065	360	62	20	0	0	0	0	0	0	0	0	0	0	0	0	0	0	0	0	0	0	0	0

Summary Graphs

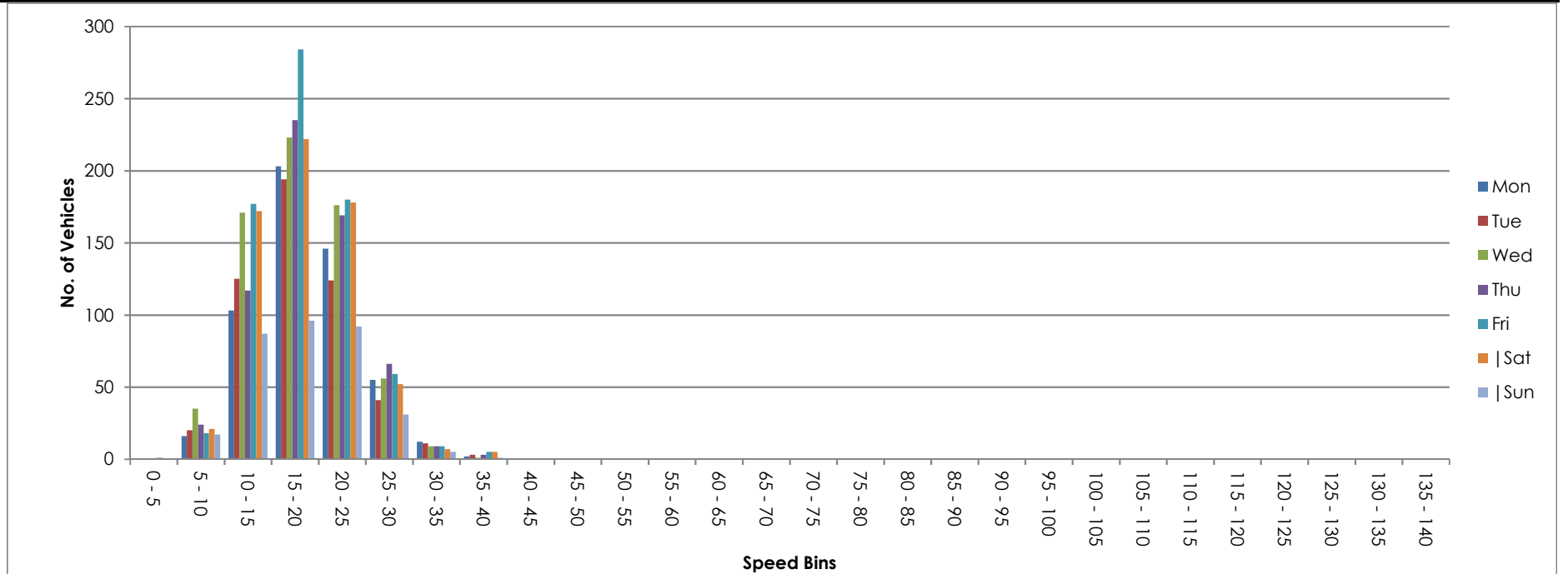

Site 1
 Location Access Road, Att - Sign, OSGR: SP 46789 37517
 Direction Westbound

8643 / Bodicote Business Park, Banbury
 September 2018
 Automatic Traffic Count

26 September 2018

Time	Total	Classification												>PSL 30	>PSL% 30	>SL1 35 ACPO	>SL1% 35 ACPO	>SL2 45 DfT	>SL2% 45 DfT	Mean	Vpp 85
		1 MCL	2 SV	3 SVT	4 TB2	5 TB3	6 T4	7 ART3	8 ART4	9 ART5	10 ART6	11 BD	12 DRT								
0000	0	0	0	0	0	0	0	0	0	0	0	0	0	0	0	0	0	0	-	-	
0100	0	0	0	0	0	0	0	0	0	0	0	0	0	0	0	0	0	0	-	-	
0200	0	0	0	0	0	0	0	0	0	0	0	0	0	0	0	0	0	0	-	-	
0300	0	0	0	0	0	0	0	0	0	0	0	0	0	0	0	0	0	0	-	-	
0400	0	0	0	0	0	0	0	0	0	0	0	0	0	0	0	0	0	0	-	-	
0500	0	0	0	0	0	0	0	0	0	0	0	0	0	0	0	0	0	0	-	-	
0600	9	1	6	0	1	1	0	0	0	0	0	0	0	0	0	0	0	0	19	-	
0700	25	0	25	0	0	0	0	0	0	0	0	0	0	0	0	0	0	0	19.1	22.4	
0800	30	1	28	0	0	0	1	0	0	0	0	0	0	0	0	0	0	0	20.3	23	
0900	62	0	57	0	5	0	0	0	0	0	0	0	0	0	0	0	0	0	16.1	18.3	
1000	59	1	56	0	1	0	0	0	1	0	0	0	0	0	0	0	0	0	16.1	20.1	
1100	58	0	53	0	5	0	0	0	0	0	0	0	0	0	0	0	0	0	14.1	17	
1200	62	1	56	0	5	0	0	0	0	0	0	0	0	0	0	0	0	0	13.8	17.4	
1300	61	1	56	1	3	0	0	0	0	0	0	0	0	0	0	0	0	0	16.3	19.7	
1400	60	0	56	0	4	0	0	0	0	0	0	0	0	0	0	0	0	0	17.1	20.4	
1500	54	0	52	1	1	0	0	0	0	0	0	0	0	0	0	0	0	0	18.6	21.9	
1600	39	0	39	0	0	0	0	0	0	0	0	0	0	0	0	0	0	0	18.8	24.2	
1700	51	0	48	0	3	0	0	0	0	0	0	0	0	0	0	0	0	0	18.9	22.4	
1800	38	2	35	0	0	0	1	0	0	0	0	0	0	0	0	0	0	0	19.9	23.3	
1900	26	0	26	0	0	0	0	0	0	0	0	0	0	0	0	0	0	0	21	24.6	
2000	21	0	19	0	2	0	0	0	0	0	0	0	0	1	4.8	0	0	0	22.1	24.6	
2100	11	0	11	0	0	0	0	0	0	0	0	0	0	0	0	0	0	0	20.4	21.3	
2200	7	0	7	0	0	0	0	0	0	0	0	0	0	0	0	0	0	0	17.5	-	
2300	1	0	1	0	0	0	0	0	0	0	0	0	0	0	0	0	0	0	28	-	
07-19	599	6	561	2	27	0	2	0	1	0	0	0	0	0	0	0	0	0	17	21.3	
06-22	666	7	623	2	30	1	2	0	1	0	0	0	0	1	0.2	0	0	0	17.4	21.9	
06-00	674	7	631	2	30	1	2	0	1	0	0	0	0	1	0.1	0	0	0	17.4	21.9	
00-00	674	7	631	2	30	1	2	0	1	0	0	0	0	1	0.1	0	0	0	17.4	21.9	



Site 1
 Location Access Road, Att - Sign, OSGR: SP 46789 37517
 Direction Westbound

8643 / Bodicote Business Park, Banbury
 September 2018
 Automatic Traffic Count

27 September 2018

Time	Total	Classification												>PSL 30	>PSL% 30	>SL1 35 ACPO	>SL1% 35 ACPO	>SL2 45 DfT	>SL2% 45 DfT	Mean	Vpp 85
		1 MCL	2 SV	3 SVT	4 TB2	5 TB3	6 T4	7 ART3	8 ART4	9 ART5	10 ART6	11 BD	12 DRT								
0000	0	0	0	0	0	0	0	0	0	0	0	0	0	0	0	0	0	0	-	-	
0100	0	0	0	0	0	0	0	0	0	0	0	0	0	0	0	0	0	0	-	-	
0200	0	0	0	0	0	0	0	0	0	0	0	0	0	0	0	0	0	0	-	-	
0300	0	0	0	0	0	0	0	0	0	0	0	0	0	0	0	0	0	0	-	-	
0400	0	0	0	0	0	0	0	0	0	0	0	0	0	0	0	0	0	0	-	-	
0500	1	0	1	0	0	0	0	0	0	0	0	0	0	0	0	0	0	0	23.3	-	
0600	5	0	4	0	0	0	0	1	0	0	0	0	0	0	0	0	0	0	21.2	-	
0700	28	0	27	0	1	0	0	0	0	0	0	0	0	0	0	0	0	0	20.1	23.9	
0800	42	3	34	0	4	1	0	0	0	0	0	0	0	0	0	0	0	0	18.8	22.8	
0900	66	2	58	0	5	0	1	0	0	0	0	0	0	0	0	0	0	0	17	20.8	
1000	52	0	51	0	1	0	0	0	0	0	0	0	0	0	0	0	0	0	15.1	17.7	
1100	56	0	52	0	3	1	0	0	0	0	0	0	0	1	1.8	0	0	0	16.8	19.9	
1200	59	1	52	0	6	0	0	0	0	0	0	0	0	0	0	0	0	0	17.1	20.8	
1300	63	0	57	0	5	0	1	0	0	0	0	0	0	1	1.6	0	0	0	18.1	21.5	
1400	49	0	41	0	6	0	2	0	0	0	0	0	0	0	0	0	0	0	16.5	21.3	
1500	32	0	28	0	1	0	3	0	0	0	0	0	0	0	0	0	0	0	16.8	20.4	
1600	35	0	33	1	1	0	0	0	0	0	0	0	0	1	2.9	0	0	0	19.9	23.3	
1700	38	0	36	0	2	0	0	0	0	0	0	0	0	2	5.3	0	0	0	20.3	25.3	
1800	26	0	25	0	1	0	0	0	0	0	0	0	0	0	0	0	0	0	20.6	23.9	
1900	22	0	21	0	1	0	0	0	0	0	0	0	0	0	0	0	0	0	20.6	24.2	
2000	25	0	25	0	0	0	0	0	0	0	0	0	0	0	0	0	0	0	22.1	25.1	
2100	8	0	8	0	0	0	0	0	0	0	0	0	0	0	0	0	0	0	21.3	-	
2200	9	0	9	0	0	0	0	0	0	0	0	0	0	0	0	0	0	0	23	-	
2300	1	0	1	0	0	0	0	0	0	0	0	0	0	0	0	0	0	0	19.3	-	
07-19	546	6	494	1	36	2	7	0	0	0	0	0	0	5	0.9	0	0	0	17.8	22.1	
06-22	606	6	552	1	37	2	7	1	0	0	0	0	0	5	0.8	0	0	0	18.1	22.4	
06-00	616	6	562	1	37	2	7	1	0	0	0	0	0	5	0.8	0	0	0	18.2	22.6	
00-00	617	6	563	1	37	2	7	1	0	0	0	0	0	5	0.8	0	0	0	18.2	22.6	



Site 1
 Location Access Road, Att - Sign, OSGR: SP 46789 37517
 Direction Westbound

8643 / Bodicote Business Park, Banbury
 September 2018
 Automatic Traffic Count

28 September 2018

Time	Total	Classification												>PSL 30	>PSL% 30	>SL1 35 ACPO	>SL1% 35 ACPO	>SL2 45 DfT	>SL2% 45 DfT	Mean	Vpp 85
		1 MCL	2 SV	3 SVT	4 TB2	5 TB3	6 T4	7 ART3	8 ART4	9 ART5	10 ART6	11 BD	12 DRT								
0000	3	0	3	0	0	0	0	0	0	0	0	0	0	0	0	0	0	0	22.3	-	
0100	0	0	0	0	0	0	0	0	0	0	0	0	0	0	0	0	0	0	-	-	
0200	0	0	0	0	0	0	0	0	0	0	0	0	0	0	0	0	0	0	-	-	
0300	0	0	0	0	0	0	0	0	0	0	0	0	0	0	0	0	0	0	-	-	
0400	0	0	0	0	0	0	0	0	0	0	0	0	0	0	0	0	0	0	-	-	
0500	5	0	4	0	1	0	0	0	0	0	0	0	0	0	0	0	0	0	17.3	-	
0600	3	0	3	0	0	0	0	0	0	0	0	0	0	0	0	0	0	0	21	-	
0700	32	0	29	0	2	1	0	0	0	0	0	0	0	1	3.1	0	0	0	19.4	23.3	
0800	42	2	35	1	1	2	1	0	0	0	0	0	0	0	0	0	0	0	17.9	21.9	
0900	61	0	54	0	4	2	1	0	0	0	0	0	0	0	0	0	0	0	17.3	19.7	
1000	69	0	64	1	2	1	1	0	0	0	0	0	0	0	0	0	0	0	15.4	18.8	
1100	78	1	72	0	1	1	3	0	0	0	0	0	0	0	0	0	0	0	16.4	20.6	
1200	67	0	64	0	3	0	0	0	0	0	0	0	0	0	0	0	0	0	16.8	20.6	
1300	74	1	67	0	5	0	1	0	0	0	0	0	0	0	0	0	0	0	16.8	22.1	
1400	42	0	38	0	4	0	0	0	0	0	0	0	0	0	0	0	0	0	17.4	21.7	
1500	46	1	43	0	2	0	0	0	0	0	0	0	0	0	0	0	0	0	18	22.4	
1600	52	0	48	0	4	0	0	0	0	0	0	0	0	1	1.9	0	0	0	19.8	21.9	
1700	41	1	40	0	0	0	0	0	0	0	0	0	0	1	2.4	0	0	0	20.1	23.5	
1800	31	0	30	0	0	1	0	0	0	0	0	0	0	0	0	0	0	0	21.1	24.6	
1900	21	0	20	0	0	1	0	0	0	0	0	0	0	1	4.8	0	0	0	19.4	22.1	
2000	19	0	19	0	0	0	0	0	0	0	0	0	0	1	5.3	0	0	0	19.8	22.8	
2100	10	0	10	0	0	0	0	0	0	0	0	0	0	0	0	0	0	0	19.3	-	
2200	14	0	14	0	0	0	0	0	0	0	0	0	0	0	0	0	0	0	20.7	23.5	
2300	4	0	4	0	0	0	0	0	0	0	0	0	0	0	0	0	0	0	19.1	-	
07-19	635	6	584	2	28	8	7	0	0	0	0	0	0	3	0.5	0	0	0	17.7	21.9	
06-22	688	6	636	2	28	9	7	0	0	0	0	0	0	5	0.7	0	0	0	17.8	22.1	
06-00	706	6	654	2	28	9	7	0	0	0	0	0	0	5	0.7	0	0	0	17.9	22.1	
00-00	714	6	661	2	29	9	7	0	0	0	0	0	0	5	0.7	0	0	0	17.9	22.1	



Site 1
 Location Access Road, Att - Sign, OSGR: SP 46789 37517
 Direction Westbound

8643 / Bodicote Business Park, Banbury
 September 2018
 Automatic Traffic Count

29 September 2018

Time	Total	Classification												>PSL 30	>PSL% 30	>SL1 35 ACPO	>SL1% 35 ACPO	>SL2 45 DfT	>SL2% 45 DfT	Mean	Vpp 85
		1 MCL	2 SV	3 SVT	4 TB2	5 TB3	6 T4	7 ART3	8 ART4	9 ART5	10 ART6	11 BD	12 DRT								
0000	3	0	3	0	0	0	0	0	0	0	0	0	0	0	0	0	0	0	22.1	-	
0100	1	0	1	0	0	0	0	0	0	0	0	0	0	0	0	0	0	0	18.7	-	
0200	1	0	0	0	1	0	0	0	0	0	0	0	0	0	0	0	0	0	16.9	-	
0300	0	0	0	0	0	0	0	0	0	0	0	0	0	0	0	0	0	0	-	-	
0400	3	0	3	0	0	0	0	0	0	0	0	0	0	0	0	0	0	0	20.2	-	
0500	1	0	1	0	0	0	0	0	0	0	0	0	0	0	0	0	0	0	10.4	-	
0600	4	0	3	0	1	0	0	0	0	0	0	0	0	0	0	0	0	0	19.4	-	
0700	10	0	9	0	1	0	0	0	0	0	0	0	0	0	0	0	0	0	17.7	-	
0800	37	1	33	0	3	0	0	0	0	0	0	0	0	1	2.7	0	0	0	17.9	20.4	
0900	60	1	53	0	5	0	0	0	0	0	1	0	0	0	0	0	0	0	18.1	21.5	
1000	76	2	66	0	3	0	1	0	0	0	1	2	1	0	0	0	0	0	17.3	21	
1100	76	2	66	0	3	1	3	0	0	0	1	0	0	1	1.3	0	0	0	16.7	19.2	
1200	57	0	52	0	3	2	0	0	0	0	0	0	0	0	0	0	0	0	17.3	22.1	
1300	42	0	40	0	2	0	0	0	0	0	0	0	0	1	2.4	0	0	0	17.5	22.1	
1400	70	0	68	1	1	0	0	0	0	0	0	0	0	0	0	0	0	0	16.3	19.5	
1500	43	0	39	1	3	0	0	0	0	0	0	0	0	0	0	0	0	0	16.9	20.1	
1600	53	0	47	2	4	0	0	0	0	0	0	0	0	0	0	0	0	0	18	21	
1700	26	0	26	0	0	0	0	0	0	0	0	0	0	1	3.8	0	0	0	20.7	24.4	
1800	24	1	22	0	1	0	0	0	0	0	0	0	0	0	0	0	0	0	18.7	21.9	
1900	20	0	20	0	0	0	0	0	0	0	0	0	0	1	5	0	0	0	20.1	26.4	
2000	16	0	15	0	1	0	0	0	0	0	0	0	0	0	0	0	0	0	20.1	23	
2100	19	0	18	0	1	0	0	0	0	0	0	0	0	0	0	0	0	0	19.9	23.9	
2200	9	0	9	0	0	0	0	0	0	0	0	0	0	0	0	0	0	0	22.8	-	
2300	4	0	4	0	0	0	0	0	0	0	0	0	0	0	0	0	0	0	19.7	-	
07-19	574	7	521	4	29	3	4	0	0	0	3	2	1	4	0.7	0	0	0	17.5	21.3	
06-22	633	7	577	4	32	3	4	0	0	0	3	2	1	5	0.8	0	0	0	17.7	21.5	
06-00	646	7	590	4	32	3	4	0	0	0	3	2	1	5	0.8	0	0	0	17.8	21.7	
00-00	655	7	598	4	33	3	4	0	0	0	3	2	1	5	0.8	0	0	0	17.8	21.7	



Site 1
 Location Access Road, Att - Sign, OSGR: SP 46789 37517
 Direction Westbound

8643 / Bodicote Business Park, Banbury
 September 2018
 Automatic Traffic Count

30 September 2018

Time	Total	Classification												>PSL 30	>PSL% 30	>SL1 35 ACPO	>SL1% 35 ACPO	>SL2 45 DfT	>SL2% 45 DfT	Mean	Vpp 85
		1 MCL	2 SV	3 SVT	4 TB2	5 TB3	6 T4	7 ART3	8 ART4	9 ART5	10 ART6	11 BD	12 DRT								
0000	6	0	6	0	0	0	0	0	0	0	0	0	0	0	0	0	0	0	21.9	-	
0100	2	0	2	0	0	0	0	0	0	0	0	0	0	0	0	0	0	0	22.8	-	
0200	1	0	1	0	0	0	0	0	0	0	0	0	0	0	0	0	0	0	14.1	-	
0300	0	0	0	0	0	0	0	0	0	0	0	0	0	0	0	0	0	0	-	-	
0400	1	0	1	0	0	0	0	0	0	0	0	0	0	0	0	0	0	0	18.2	-	
0500	0	0	0	0	0	0	0	0	0	0	0	0	0	0	0	0	0	0	-	-	
0600	1	0	1	0	0	0	0	0	0	0	0	0	0	0	0	0	0	0	17.7	-	
0700	3	1	2	0	0	0	0	0	0	0	0	0	0	0	0	0	0	0	18.3	-	
0800	3	0	3	0	0	0	0	0	0	0	0	0	0	0	0	0	0	0	19.8	-	
0900	9	0	9	0	0	0	0	0	0	0	0	0	0	0	0	0	0	0	17.9	-	
1000	37	0	35	1	0	1	0	0	0	0	0	0	0	0	0	0	0	0	15.5	18.8	
1100	43	0	42	0	0	1	0	0	0	0	0	0	0	0	0	0	0	0	16.2	20.8	
1200	49	0	46	0	1	1	1	0	0	0	0	0	0	0	0	0	0	0	16.1	21.3	
1300	38	0	37	0	1	0	0	0	0	0	0	0	0	0	0	0	0	0	15.6	20.8	
1400	30	0	30	0	0	0	0	0	0	0	0	0	0	1	3.3	0	0	0	18	21.9	
1500	30	1	28	0	1	0	0	0	0	0	0	0	0	0	0	0	0	0	17.6	23	
1600	17	0	17	0	0	0	0	0	0	0	0	0	0	0	0	0	0	0	18.6	21.5	
1700	19	1	18	0	0	0	0	0	0	0	0	0	0	0	0	0	0	0	17	19.2	
1800	15	0	15	0	0	0	0	0	0	0	0	0	0	0	0	0	0	0	19.9	23.3	
1900	16	0	16	0	0	0	0	0	0	0	0	0	0	0	0	0	0	0	22.2	24.8	
2000	11	0	11	0	0	0	0	0	0	0	0	0	0	0	0	0	0	0	21.9	24.8	
2100	15	1	14	0	0	0	0	0	0	0	0	0	0	1	6.7	0	0	0	21.6	25.3	
2200	5	1	4	0	0	0	0	0	0	0	0	0	0	0	0	0	0	0	20	-	
2300	1	0	1	0	0	0	0	0	0	0	0	0	0	0	0	0	0	0	22.2	-	
07-19	293	3	282	1	3	3	1	0	0	0	0	0	0	1	0.3	0	0	0	16.8	21.5	
06-22	336	4	324	1	3	3	1	0	0	0	0	0	0	2	0.6	0	0	0	17.5	22.1	
06-00	342	5	329	1	3	3	1	0	0	0	0	0	0	2	0.6	0	0	0	17.5	22.4	
00-00	352	5	339	1	3	3	1	0	0	0	0	0	0	2	0.6	0	0	0	17.6	22.4	



Site 1
 Location Access Road, Att - Sign, OSGR: SP 46789 37517
 Direction Westbound

8643 / Bodicote Business Park, Banbury
 September 2018
 Automatic Traffic Count

01 October 2018

Time	Total	Classification												>PSL 30	>PSL% 30	>SL1 35 ACPO	>SL1% 35 ACPO	>SL2 45 DfT	>SL2% 45 DfT	Mean	Vpp 85
		1 MCL	2 SV	3 SVT	4 TB2	5 TB3	6 T4	7 ART3	8 ART4	9 ART5	10 ART6	11 BD	12 DRT								
0000	0	0	0	0	0	0	0	0	0	0	0	0	0	0	0	0	0	0	-	-	
0100	0	0	0	0	0	0	0	0	0	0	0	0	0	0	0	0	0	0	-	-	
0200	0	0	0	0	0	0	0	0	0	0	0	0	0	0	0	0	0	0	-	-	
0300	1	0	1	0	0	0	0	0	0	0	0	0	0	0	0	0	0	0	23.8	-	
0400	0	0	0	0	0	0	0	0	0	0	0	0	0	0	0	0	0	0	-	-	
0500	0	0	0	0	0	0	0	0	0	0	0	0	0	0	0	0	0	0	-	-	
0600	5	0	4	0	1	0	0	0	0	0	0	0	0	0	0	0	0	0	20.6	-	
0700	28	1	26	0	0	1	0	0	0	0	0	0	0	0	0	0	0	0	18.8	22.1	
0800	34	1	32	0	0	0	1	0	0	0	0	0	0	0	0	0	0	0	19.8	23	
0900	28	1	23	0	4	0	0	0	0	0	0	0	0	0	0	0	0	0	18.1	23.7	
1000	61	0	57	0	3	0	1	0	0	0	0	0	0	0	0	0	0	0	17.1	20.8	
1100	64	0	55	0	5	3	1	0	0	0	0	0	0	0	0	0	0	0	16.8	20.4	
1200	49	0	46	0	2	1	0	0	0	0	0	0	0	0	0	0	0	0	15.8	18.6	
1300	44	0	40	1	3	0	0	0	0	0	0	0	0	0	0	0	0	0	16.6	19.2	
1400	43	0	43	0	0	0	0	0	0	0	0	0	0	0	0	0	0	0	17.5	21.9	
1500	45	1	41	1	2	0	0	0	0	0	0	0	0	0	0	0	0	0	17.4	20.4	
1600	32	0	30	0	1	1	0	0	0	0	0	0	0	0	0	0	0	0	20.2	23.3	
1700	38	1	36	1	0	0	0	0	0	0	0	0	0	1	2.6	0	0	0	21.4	25.7	
1800	34	0	32	0	1	1	0	0	0	0	0	0	0	0	0	0	0	0	21.2	24.2	
1900	21	0	21	0	0	0	0	0	0	0	0	0	0	0	0	0	0	0	21.6	25.3	
2000	10	0	10	0	0	0	0	0	0	0	0	0	0	0	0	0	0	0	22.8	-	
2100	10	0	10	0	0	0	0	0	0	0	0	0	0	0	0	0	0	0	21.2	-	
2200	5	0	5	0	0	0	0	0	0	0	0	0	0	0	0	0	0	0	23.1	-	
2300	1	0	1	0	0	0	0	0	0	0	0	0	0	0	0	0	0	0	24.5	-	
07-19	500	5	461	3	21	7	3	0	0	0	0	0	0	1	0.2	0	0	0	18.1	22.8	
06-22	546	5	506	3	22	7	3	0	0	0	0	0	0	1	0.2	0	0	0	18.4	22.8	
06-00	552	5	512	3	22	7	3	0	0	0	0	0	0	1	0.2	0	0	0	18.4	22.8	
00-00	553	5	513	3	22	7	3	0	0	0	0	0	0	1	0.2	0	0	0	18.5	23	



Site 1
 Location Access Road, Att - Sign, OSGR: SP 46789 37517
 Direction Westbound

8643 / Bodicote Business Park, Banbury
 September 2018
 Automatic Traffic Count

02 October 2018

Time	Total	Classification												>PSL 30	>PSL% 30	>SL1 35 ACPO	>SL1% 35 ACPO	>SL2 45 DfT	>SL2% 45 DfT	Mean	Vpp 85
		1 MCL	2 SV	3 SVT	4 TB2	5 TB3	6 T4	7 ART3	8 ART4	9 ART5	10 ART6	11 BD	12 DRT								
0000	0	0	0	0	0	0	0	0	0	0	0	0	0	0	0	0	0	0	-	-	
0100	0	0	0	0	0	0	0	0	0	0	0	0	0	0	0	0	0	0	-	-	
0200	0	0	0	0	0	0	0	0	0	0	0	0	0	0	0	0	0	0	-	-	
0300	0	0	0	0	0	0	0	0	0	0	0	0	0	0	0	0	0	0	-	-	
0400	0	0	0	0	0	0	0	0	0	0	0	0	0	0	0	0	0	0	-	-	
0500	1	0	1	0	0	0	0	0	0	0	0	0	0	0	0	0	0	0	20.1	-	
0600	4	0	4	0	0	0	0	0	0	0	0	0	0	0	0	0	0	0	19.8	-	
0700	27	0	23	0	3	0	0	0	0	0	1	0	0	0	0	0	0	0	17.5	21.3	
0800	37	2	31	0	2	0	2	0	0	0	0	0	0	0	0	0	0	0	16.2	19.2	
0900	31	0	29	0	1	1	0	0	0	0	0	0	0	3	9.7	0	0	0	18.3	20.8	
1000	50	0	46	0	4	0	0	0	0	0	0	0	0	0	0	0	0	0	15.8	18.6	
1100	43	1	34	0	5	3	0	0	0	0	0	0	0	0	0	0	0	0	16.2	19	
1200	56	0	50	1	5	0	0	0	0	0	0	0	0	0	0	0	0	0	16.1	19.5	
1300	43	0	39	0	4	0	0	0	0	0	0	0	0	0	0	0	0	0	15.7	20.1	
1400	47	2	37	0	5	3	0	0	0	0	0	0	0	0	0	0	0	0	14.9	19	
1500	39	0	36	0	2	0	0	0	0	1	0	0	0	0	0	0	0	0	17.3	21.5	
1600	34	2	31	0	1	0	0	0	0	0	0	0	0	1	2.9	0	0	0	18.5	21.9	
1700	30	0	28	0	2	0	0	0	0	0	0	0	0	0	0	0	0	0	22	24.2	
1800	30	2	27	0	1	0	0	0	0	0	0	0	0	0	0	0	0	0	20.1	23.9	
1900	19	2	16	0	1	0	0	0	0	0	0	0	0	0	0	0	0	0	21.2	22.8	
2000	19	0	19	0	0	0	0	0	0	0	0	0	0	1	5.3	0	0	0	22.5	26.6	
2100	10	0	10	0	0	0	0	0	0	0	0	0	0	1	10	1	10	0	23	-	
2200	7	0	7	0	0	0	0	0	0	0	0	0	0	0	0	0	0	0	21.5	-	
2300	0	0	0	0	0	0	0	0	0	0	0	0	0	0	0	0	0	0	0	0	
07-19	467	9	411	1	35	7	2	0	0	1	1	0	0	4	0.9	0	0	0	0	17.1	21.7
06-22	519	11	460	1	36	7	2	0	0	1	1	0	0	6	1.2	1	0.2	0	0	17.5	22.1
06-00	526	11	467	1	36	7	2	0	0	1	1	0	0	6	1.1	1	0.2	0	0	17.6	22.1
00-00	527	11	468	1	36	7	2	0	0	1	1	0	0	6	1.1	1	0.2	0	0	17.6	22.1



Site 1
 Location Access Road, Att - Sign, OSGR: SP 46789 37517
 Direction Westbound

8643 / Bodicote Business Park, Banbury
 September 2018
 Automatic Traffic Count

Virtual Day (7)

Time	Total	Classification												>PSL 30	>PSL% 30	>SL1 35 ACPO	>SL1% 35 ACPO	>SL2 45 DfT	>SL2% 45 DfT	Mean	Vpp 85
		1 MCL	2 SV	3 SVT	4 TB2	5 TB3	6 T4	7 ART3	8 ART4	9 ART5	10 ART6	11 BD	12 DRT								
0000	2	0	2	0	0	0	0	0	0	0	0	0	0	0	0	0	0	0	22.1	-	
0100	0	0	0	0	0	0	0	0	0	0	0	0	0	0	0	0	0	0	21.4	-	
0200	0	0	0	0	0	0	0	0	0	0	0	0	0	0	0	0	0	0	15.5	-	
0300	0	0	0	0	0	0	0	0	0	0	0	0	0	0	0	0	0	0	23.8	-	
0400	1	0	1	0	0	0	0	0	0	0	0	0	0	0	0	0	0	0	19.7	-	
0500	1	0	1	0	0	0	0	0	0	0	0	0	0	0	0	0	0	0	17.6	-	
0600	4	0	4	0	0	0	0	0	0	0	0	0	0	0	0	0	0	0	19.9	-	
0700	22	0	20	0	1	0	0	0	0	0	0	0	0	0	0.7	0	0	0	18.9	23	
0800	32	1	28	0	1	0	1	0	0	0	0	0	0	0	0.4	0	0	0	18.4	22.4	
0900	45	1	40	0	3	0	0	0	0	0	0	0	0	0	0.9	0	0	0	17.3	20.8	
1000	58	0	54	0	2	0	0	0	0	0	0	0	0	0	0	0	0	0	16.1	19.9	
1100	60	1	53	0	3	1	1	0	0	0	0	0	0	0	0.5	0	0	0	16.2	19.5	
1200	57	0	52	0	4	1	0	0	0	0	0	0	0	0	0	0	0	0	16.1	20.6	
1300	52	0	48	0	3	0	0	0	0	0	0	0	0	0	0.5	0	0	0	16.7	21	
1400	49	0	45	0	3	0	0	0	0	0	0	0	0	0	0.3	0	0	0	16.7	20.6	
1500	41	0	38	0	2	0	0	0	0	0	0	0	0	0	0	0	0	0	17.6	21.7	
1600	37	0	35	0	2	0	0	0	0	0	0	0	0	0	1.1	0	0	0	19.1	22.6	
1700	35	0	33	0	1	0	0	0	0	0	0	0	0	1	2.1	0	0	0	20.2	24.4	
1800	28	1	27	0	1	0	0	0	0	0	0	0	0	0	0	0	0	0	20.3	23.9	
1900	21	0	20	0	0	0	0	0	0	0	0	0	0	0	1.4	0	0	0	20.8	24.6	
2000	17	0	17	0	0	0	0	0	0	0	0	0	0	0	2.5	0	0	0	21.6	25.1	
2100	12	0	12	0	0	0	0	0	0	0	0	0	0	0	2.4	0	1.2	0	20.9	24.4	
2200	8	0	8	0	0	0	0	0	0	0	0	0	0	0	0	0	0	0	21.3	-	
2300	2	0	2	0	0	0	0	0	0	0	0	0	0	0	0	0	0	0	20.8	-	
07-19	516	6	473	2	26	4	4	0	0	0	1	0	0	3	0.5	0	0	0	17.5	21.7	
06-22	571	7	525	2	27	5	4	0	0	0	1	0	0	4	0.6	0	0	0	17.8	22.1	
06-00	580	7	535	2	27	5	4	0	0	0	1	0	0	4	0.6	0	0	0	17.8	22.1	
00-00	585	7	539	2	27	5	4	0	0	0	1	0	0	4	0.6	0	0	0	17.9	22.1	



Site 1
 Location Access Road, Att - Sign, OSGR: SP 46789 37517
 Direction Westbound

8643 / Bodicote Business Park, Banbury
 September 2018
 Automatic Traffic Count

Virtual Week (1)

Time	Total	Classification												>PSL 30	>PSL% 30	>SL1 35 ACPO	>SL1% 35 ACPO	>SL2 45 DfT	>SL2% 45 DfT	Mean	Vpp 85
		1 MCL	2 SV	3 SVT	4 TB2	5 TB3	6 T4	7 ART3	8 ART4	9 ART5	10 ART6	11 BD	12 DRT								
Mon	553	5	513	3	22	7	3	0	0	0	0	0	0	1	0.2	0	0	0	0	18.5	23
Tue	527	11	468	1	36	7	2	0	0	1	1	0	0	6	1.1	1	0.2	0	0	17.6	22.1
Wed	674	7	631	2	30	1	2	0	1	0	0	0	0	1	0.1	0	0	0	0	17.4	21.9
Thu	617	6	563	1	37	2	7	1	0	0	0	0	0	5	0.8	0	0	0	0	18.2	22.6
Fri	714	6	661	2	29	9	7	0	0	0	0	0	0	5	0.7	0	0	0	0	17.9	22.1
Sat	655	7	598	4	33	3	4	0	0	0	3	2	1	5	0.8	0	0	0	0	17.8	21.7
Sun	352	5	339	1	3	3	1	0	0	0	0	0	0	2	0.6	0	0	0	0	17.6	22.4
5 Day Ave.	617	7	567	2	31	5	4	0	0	0	0	0	0	4	0.6	0	0.0	0	0.0	17.9	22.3
7 Day Ave.	585	7	539	2	27	5	4	0	0	0	1	0	0	4	0.6	0	0.0	0	0.0	17.9	22.1
--	4092	47	3773	14	190	32	26	1	1	1	4	2	1	25	0.6	1	0.0	0	0.0	17.9	22.1

Summary Graphs

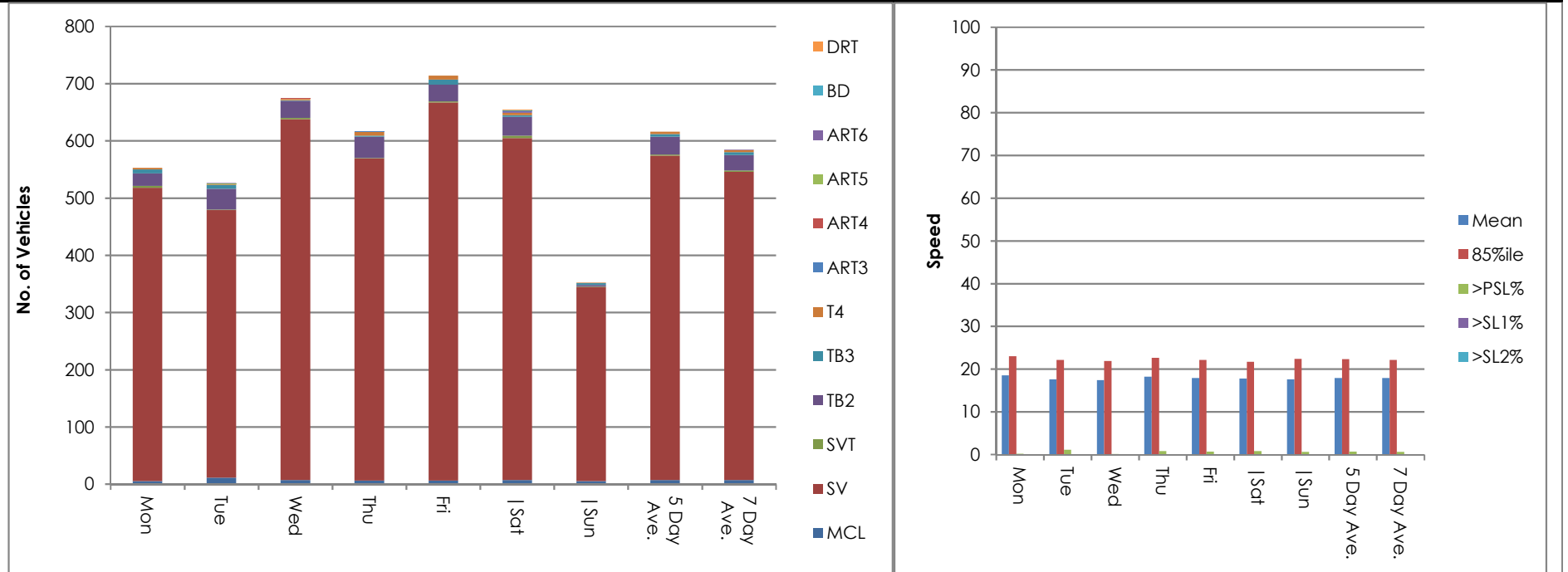

Site 1
 Location Access Road, Att - Sign, OSGR: SP 46789 37517
 Direction Westbound

8643 / Bodicote Business Park, Banbury
 September 2018
 Automatic Traffic Count

26 September 2018

Time	Total	Speed Bins (mph)																											
		0 - 5	5 - 10	10 - 15	15 - 20	20 - 25	25 - 30	30 - 35	35 - 40	40 - 45	45 - 50	50 - 55	55 - 60	60 - 65	65 - 70	70 - 75	75 - 80	80 - 85	85 - 90	90 - 95	95 - 100	100 - 105	105 - 110	110 - 115	115 - 120	120 - 125	125 - 130	130 - 135	135 - 140
0000	0	0	0	0	0	0	0	0	0	0	0	0	0	0	0	0	0	0	0	0	0	0	0	0	0	0	0	0	
0100	0	0	0	0	0	0	0	0	0	0	0	0	0	0	0	0	0	0	0	0	0	0	0	0	0	0	0	0	0
0200	0	0	0	0	0	0	0	0	0	0	0	0	0	0	0	0	0	0	0	0	0	0	0	0	0	0	0	0	0
0300	0	0	0	0	0	0	0	0	0	0	0	0	0	0	0	0	0	0	0	0	0	0	0	0	0	0	0	0	0
0400	0	0	0	0	0	0	0	0	0	0	0	0	0	0	0	0	0	0	0	0	0	0	0	0	0	0	0	0	0
0500	0	0	0	0	0	0	0	0	0	0	0	0	0	0	0	0	0	0	0	0	0	0	0	0	0	0	0	0	0
0600	9	0	0	2	3	4	0	0	0	0	0	0	0	0	0	0	0	0	0	0	0	0	0	0	0	0	0	0	0
0700	25	0	0	1	14	10	0	0	0	0	0	0	0	0	0	0	0	0	0	0	0	0	0	0	0	0	0	0	0
0800	30	0	0	1	14	13	2	0	0	0	0	0	0	0	0	0	0	0	0	0	0	0	0	0	0	0	0	0	0
0900	62	0	1	19	37	4	1	0	0	0	0	0	0	0	0	0	0	0	0	0	0	0	0	0	0	0	0	0	0
1000	59	1	3	17	28	8	2	0	0	0	0	0	0	0	0	0	0	0	0	0	0	0	0	0	0	0	0	0	0
1100	58	0	7	23	27	1	0	0	0	0	0	0	0	0	0	0	0	0	0	0	0	0	0	0	0	0	0	0	0
1200	62	0	11	28	21	2	0	0	0	0	0	0	0	0	0	0	0	0	0	0	0	0	0	0	0	0	0	0	0
1300	61	0	4	17	31	9	0	0	0	0	0	0	0	0	0	0	0	0	0	0	0	0	0	0	0	0	0	0	0
1400	60	0	2	14	30	13	1	0	0	0	0	0	0	0	0	0	0	0	0	0	0	0	0	0	0	0	0	0	0
1500	54	0	1	7	29	14	3	0	0	0	0	0	0	0	0	0	0	0	0	0	0	0	0	0	0	0	0	0	0
1600	39	0	1	8	16	9	5	0	0	0	0	0	0	0	0	0	0	0	0	0	0	0	0	0	0	0	0	0	0
1700	51	0	1	6	23	18	3	0	0	0	0	0	0	0	0	0	0	0	0	0	0	0	0	0	0	0	0	0	0
1800	38	1	0	2	16	15	4	0	0	0	0	0	0	0	0	0	0	0	0	0	0	0	0	0	0	0	0	0	0
1900	26	0	1	2	8	11	4	0	0	0	0	0	0	0	0	0	0	0	0	0	0	0	0	0	0	0	0	0	0
2000	21	0	0	1	4	13	2	1	0	0	0	0	0	0	0	0	0	0	0	0	0	0	0	0	0	0	0	0	0
2100	11	0	0	0	4	7	0	0	0	0	0	0	0	0	0	0	0	0	0	0	0	0	0	0	0	0	0	0	0
2200	7	0	0	1	4	2	0	0	0	0	0	0	0	0	0	0	0	0	0	0	0	0	0	0	0	0	0	0	0
2300	1	0	0	0	0	0	1	0	0	0	0	0	0	0	0	0	0	0	0	0	0	0	0	0	0	0	0	0	0
07-19	599	2	31	143	286	116	21	0	0	0	0	0	0	0	0	0	0	0	0	0	0	0	0	0	0	0	0	0	0
06-22	666	2	32	148	305	151	27	1	0	0	0	0	0	0	0	0	0	0	0	0	0	0	0	0	0	0	0	0	0
06-00	674	2	32	149	309	153	28	1	0	0	0	0	0	0	0	0	0	0	0	0	0	0	0	0	0	0	0	0	0
00-00	674	2	32	149	309	153	28	1	0	0	0	0	0	0	0	0	0	0	0	0	0	0	0	0	0	0	0	0	0



Site 1
 Location Access Road, Att - Sign, OSGR: SP 46789 37517
 Direction Westbound

8643 / Bodicote Business Park, Banbury
 September 2018
 Automatic Traffic Count

27 September 2018

Time	Total	Speed Bins (mph)																											
		0 - 5	5 - 10	10 - 15	15 - 20	20 - 25	25 - 30	30 - 35	35 - 40	40 - 45	45 - 50	50 - 55	55 - 60	60 - 65	65 - 70	70 - 75	75 - 80	80 - 85	85 - 90	90 - 95	95 - 100	100 - 105	105 - 110	110 - 115	115 - 120	120 - 125	125 - 130	130 - 135	135 - 140
0000	0	0	0	0	0	0	0	0	0	0	0	0	0	0	0	0	0	0	0	0	0	0	0	0	0	0	0	0	
0100	0	0	0	0	0	0	0	0	0	0	0	0	0	0	0	0	0	0	0	0	0	0	0	0	0	0	0	0	0
0200	0	0	0	0	0	0	0	0	0	0	0	0	0	0	0	0	0	0	0	0	0	0	0	0	0	0	0	0	0
0300	0	0	0	0	0	0	0	0	0	0	0	0	0	0	0	0	0	0	0	0	0	0	0	0	0	0	0	0	0
0400	0	0	0	0	0	0	0	0	0	0	0	0	0	0	0	0	0	0	0	0	0	0	0	0	0	0	0	0	0
0500	1	0	0	0	0	1	0	0	0	0	0	0	0	0	0	0	0	0	0	0	0	0	0	0	0	0	0	0	0
0600	5	0	0	1	0	3	1	0	0	0	0	0	0	0	0	0	0	0	0	0	0	0	0	0	0	0	0	0	0
0700	28	0	0	1	13	13	1	0	0	0	0	0	0	0	0	0	0	0	0	0	0	0	0	0	0	0	0	0	0
0800	42	0	0	7	17	15	3	0	0	0	0	0	0	0	0	0	0	0	0	0	0	0	0	0	0	0	0	0	0
0900	66	0	3	15	35	12	1	0	0	0	0	0	0	0	0	0	0	0	0	0	0	0	0	0	0	0	0	0	0
1000	52	0	4	18	26	4	0	0	0	0	0	0	0	0	0	0	0	0	0	0	0	0	0	0	0	0	0	0	0
1100	56	0	0	13	34	8	0	1	0	0	0	0	0	0	0	0	0	0	0	0	0	0	0	0	0	0	0	0	0
1200	59	0	1	17	25	15	1	0	0	0	0	0	0	0	0	0	0	0	0	0	0	0	0	0	0	0	0	0	0
1300	63	0	1	15	27	16	3	1	0	0	0	0	0	0	0	0	0	0	0	0	0	0	0	0	0	0	0	0	0
1400	49	0	4	14	20	9	2	0	0	0	0	0	0	0	0	0	0	0	0	0	0	0	0	0	0	0	0	0	0
1500	32	0	0	15	10	6	1	0	0	0	0	0	0	0	0	0	0	0	0	0	0	0	0	0	0	0	0	0	0
1600	35	0	0	4	14	14	2	1	0	0	0	0	0	0	0	0	0	0	0	0	0	0	0	0	0	0	0	0	0
1700	38	0	1	5	12	12	6	2	0	0	0	0	0	0	0	0	0	0	0	0	0	0	0	0	0	0	0	0	0
1800	26	1	0	0	8	15	2	0	0	0	0	0	0	0	0	0	0	0	0	0	0	0	0	0	0	0	0	0	0
1900	22	0	0	2	7	10	3	0	0	0	0	0	0	0	0	0	0	0	0	0	0	0	0	0	0	0	0	0	0
2000	25	0	0	0	8	12	5	0	0	0	0	0	0	0	0	0	0	0	0	0	0	0	0	0	0	0	0	0	0
2100	8	0	0	0	3	4	1	0	0	0	0	0	0	0	0	0	0	0	0	0	0	0	0	0	0	0	0	0	0
2200	9	0	0	0	2	4	3	0	0	0	0	0	0	0	0	0	0	0	0	0	0	0	0	0	0	0	0	0	0
2300	1	0	0	0	1	0	0	0	0	0	0	0	0	0	0	0	0	0	0	0	0	0	0	0	0	0	0	0	0
07-19	546	1	14	124	241	139	22	5	0	0	0	0	0	0	0	0	0	0	0	0	0	0	0	0	0	0	0	0	0
06-22	606	1	14	127	259	168	32	5	0	0	0	0	0	0	0	0	0	0	0	0	0	0	0	0	0	0	0	0	0
06-00	616	1	14	127	262	172	35	5	0	0	0	0	0	0	0	0	0	0	0	0	0	0	0	0	0	0	0	0	0
00-00	617	1	14	127	262	173	35	5	0	0	0	0	0	0	0	0	0	0	0	0	0	0	0	0	0	0	0	0	0



Site 1
 Location Access Road, Att - Sign, OSGR: SP 46789 37517
 Direction Westbound

8643 / Bodicote Business Park, Banbury
 September 2018
 Automatic Traffic Count

28 September 2018

Time	Total	Speed Bins (mph)																										
		0 - 5	5 - 10	10 - 15	15 - 20	20 - 25	25 - 30	30 - 35	35 - 40	40 - 45	45 - 50	50 - 55	55 - 60	60 - 65	65 - 70	70 - 75	75 - 80	80 - 85	85 - 90	90 - 95	95 - 100	100 - 105	105 - 110	110 - 115	115 - 120	120 - 125	125 - 130	130 - 135
0000	3	0	0	0	0	3	0	0	0	0	0	0	0	0	0	0	0	0	0	0	0	0	0	0	0	0	0	0
0100	0	0	0	0	0	0	0	0	0	0	0	0	0	0	0	0	0	0	0	0	0	0	0	0	0	0	0	0
0200	0	0	0	0	0	0	0	0	0	0	0	0	0	0	0	0	0	0	0	0	0	0	0	0	0	0	0	0
0300	0	0	0	0	0	0	0	0	0	0	0	0	0	0	0	0	0	0	0	0	0	0	0	0	0	0	0	0
0400	0	0	0	0	0	0	0	0	0	0	0	0	0	0	0	0	0	0	0	0	0	0	0	0	0	0	0	0
0500	5	1	0	0	3	0	1	0	0	0	0	0	0	0	0	0	0	0	0	0	0	0	0	0	0	0	0	0
0600	3	0	0	0	2	0	1	0	0	0	0	0	0	0	0	0	0	0	0	0	0	0	0	0	0	0	0	
0700	32	0	0	3	17	9	2	1	0	0	0	0	0	0	0	0	0	0	0	0	0	0	0	0	0	0	0	
0800	42	0	1	8	20	9	4	0	0	0	0	0	0	0	0	0	0	0	0	0	0	0	0	0	0	0	0	
0900	61	0	1	11	40	7	2	0	0	0	0	0	0	0	0	0	0	0	0	0	0	0	0	0	0	0	0	
1000	69	2	1	35	23	8	0	0	0	0	0	0	0	0	0	0	0	0	0	0	0	0	0	0	0	0	0	
1100	78	0	0	31	34	11	2	0	0	0	0	0	0	0	0	0	0	0	0	0	0	0	0	0	0	0	0	
1200	67	2	4	20	23	15	3	0	0	0	0	0	0	0	0	0	0	0	0	0	0	0	0	0	0	0	0	
1300	74	0	7	21	29	15	2	0	0	0	0	0	0	0	0	0	0	0	0	0	0	0	0	0	0	0	0	
1400	42	0	0	14	15	11	2	0	0	0	0	0	0	0	0	0	0	0	0	0	0	0	0	0	0	0	0	
1500	46	0	1	6	25	11	3	0	0	0	0	0	0	0	0	0	0	0	0	0	0	0	0	0	0	0	0	
1600	52	0	1	4	17	27	2	1	0	0	0	0	0	0	0	0	0	0	0	0	0	0	0	0	0	0	0	
1700	41	0	1	4	13	19	3	1	0	0	0	0	0	0	0	0	0	0	0	0	0	0	0	0	0	0	0	
1800	31	0	0	1	9	17	4	0	0	0	0	0	0	0	0	0	0	0	0	0	0	0	0	0	0	0	0	
1900	21	0	0	3	10	7	0	1	0	0	0	0	0	0	0	0	0	0	0	0	0	0	0	0	0	0	0	
2000	19	0	0	4	5	7	2	1	0	0	0	0	0	0	0	0	0	0	0	0	0	0	0	0	0	0	0	
2100	10	0	1	0	5	4	0	0	0	0	0	0	0	0	0	0	0	0	0	0	0	0	0	0	0	0	0	
2200	14	0	0	1	5	6	2	0	0	0	0	0	0	0	0	0	0	0	0	0	0	0	0	0	0	0	0	
2300	4	0	0	0	3	1	0	0	0	0	0	0	0	0	0	0	0	0	0	0	0	0	0	0	0	0	0	
07-19	635	4	17	158	265	159	29	3	0	0	0	0	0	0	0	0	0	0	0	0	0	0	0	0	0	0	0	
06-22	688	4	18	165	287	177	32	5	0	0	0	0	0	0	0	0	0	0	0	0	0	0	0	0	0	0	0	
06-00	706	4	18	166	295	184	34	5	0	0	0	0	0	0	0	0	0	0	0	0	0	0	0	0	0	0	0	
00-00	714	5	18	166	298	187	35	5	0	0	0	0	0	0	0	0	0	0	0	0	0	0	0	0	0	0	0	



Site 1
 Location Access Road, Att - Sign, OSGR: SP 46789 37517
 Direction Westbound

8643 / Bodicote Business Park, Banbury
 September 2018
 Automatic Traffic Count

29 September 2018

Time	Total	Speed Bins (mph)																										
		0 - 5	5 - 10	10 - 15	15 - 20	20 - 25	25 - 30	30 - 35	35 - 40	40 - 45	45 - 50	50 - 55	55 - 60	60 - 65	65 - 70	70 - 75	75 - 80	80 - 85	85 - 90	90 - 95	95 - 100	100 - 105	105 - 110	110 - 115	115 - 120	120 - 125	125 - 130	130 - 135
0000	3	0	0	0	1	1	1	0	0	0	0	0	0	0	0	0	0	0	0	0	0	0	0	0	0	0	0	0
0100	1	0	0	0	1	0	0	0	0	0	0	0	0	0	0	0	0	0	0	0	0	0	0	0	0	0	0	0
0200	1	0	0	0	1	0	0	0	0	0	0	0	0	0	0	0	0	0	0	0	0	0	0	0	0	0	0	0
0300	0	0	0	0	0	0	0	0	0	0	0	0	0	0	0	0	0	0	0	0	0	0	0	0	0	0	0	0
0400	3	0	0	0	1	2	0	0	0	0	0	0	0	0	0	0	0	0	0	0	0	0	0	0	0	0	0	0
0500	1	0	0	1	0	0	0	0	0	0	0	0	0	0	0	0	0	0	0	0	0	0	0	0	0	0	0	0
0600	4	0	0	1	0	3	0	0	0	0	0	0	0	0	0	0	0	0	0	0	0	0	0	0	0	0	0	0
0700	10	0	0	2	6	1	1	0	0	0	0	0	0	0	0	0	0	0	0	0	0	0	0	0	0	0	0	0
0800	37	0	1	7	21	7	0	1	0	0	0	0	0	0	0	0	0	0	0	0	0	0	0	0	0	0	0	0
0900	60	0	3	4	34	18	1	0	0	0	0	0	0	0	0	0	0	0	0	0	0	0	0	0	0	0	0	0
1000	76	0	0	21	36	18	1	0	0	0	0	0	0	0	0	0	0	0	0	0	0	0	0	0	0	0	0	0
1100	76	0	5	15	49	5	1	1	0	0	0	0	0	0	0	0	0	0	0	0	0	0	0	0	0	0	0	0
1200	57	0	5	14	17	20	1	0	0	0	0	0	0	0	0	0	0	0	0	0	0	0	0	0	0	0	0	0
1300	42	0	2	12	16	11	0	1	0	0	0	0	0	0	0	0	0	0	0	0	0	0	0	0	0	0	0	0
1400	70	0	3	23	35	8	1	0	0	0	0	0	0	0	0	0	0	0	0	0	0	0	0	0	0	0	0	0
1500	43	1	1	8	25	8	0	0	0	0	0	0	0	0	0	0	0	0	0	0	0	0	0	0	0	0	0	0
1600	53	0	0	10	28	15	0	0	0	0	0	0	0	0	0	0	0	0	0	0	0	0	0	0	0	0	0	0
1700	26	0	0	0	14	9	2	1	0	0	0	0	0	0	0	0	0	0	0	0	0	0	0	0	0	0	0	0
1800	24	0	1	1	14	8	0	0	0	0	0	0	0	0	0	0	0	0	0	0	0	0	0	0	0	0	0	0
1900	20	0	0	2	13	1	3	1	0	0	0	0	0	0	0	0	0	0	0	0	0	0	0	0	0	0	0	0
2000	16	0	0	0	8	7	1	0	0	0	0	0	0	0	0	0	0	0	0	0	0	0	0	0	0	0	0	0
2100	19	0	1	1	7	7	3	0	0	0	0	0	0	0	0	0	0	0	0	0	0	0	0	0	0	0	0	0
2200	9	0	0	0	2	5	2	0	0	0	0	0	0	0	0	0	0	0	0	0	0	0	0	0	0	0	0	0
2300	4	0	0	0	2	2	0	0	0	0	0	0	0	0	0	0	0	0	0	0	0	0	0	0	0	0	0	0
07-19	574	1	21	117	295	128	8	4	0	0	0	0	0	0	0	0	0	0	0	0	0	0	0	0	0	0	0	0
06-22	633	1	22	121	323	146	15	5	0	0	0	0	0	0	0	0	0	0	0	0	0	0	0	0	0	0	0	0
06-00	646	1	22	121	327	153	17	5	0	0	0	0	0	0	0	0	0	0	0	0	0	0	0	0	0	0	0	0
00-00	655	1	22	122	331	156	18	5	0	0	0	0	0	0	0	0	0	0	0	0	0	0	0	0	0	0	0	0



Site 1
 Location Access Road, Att - Sign, OSGR: SP 46789 37517
 Direction Westbound

8643 / Bodicote Business Park, Banbury
 September 2018
 Automatic Traffic Count

30 September 2018

Time	Total	Speed Bins (mph)																										
		0 - 5	5 - 10	10 - 15	15 - 20	20 - 25	25 - 30	30 - 35	35 - 40	40 - 45	45 - 50	50 - 55	55 - 60	60 - 65	65 - 70	70 - 75	75 - 80	80 - 85	85 - 90	90 - 95	95 - 100	100 - 105	105 - 110	110 - 115	115 - 120	120 - 125	125 - 130	130 - 135
0000	6	0	0	0	2	3	1	0	0	0	0	0	0	0	0	0	0	0	0	0	0	0	0	0	0	0	0	0
0100	2	0	0	0	0	2	0	0	0	0	0	0	0	0	0	0	0	0	0	0	0	0	0	0	0	0	0	0
0200	1	0	0	1	0	0	0	0	0	0	0	0	0	0	0	0	0	0	0	0	0	0	0	0	0	0	0	0
0300	0	0	0	0	0	0	0	0	0	0	0	0	0	0	0	0	0	0	0	0	0	0	0	0	0	0	0	0
0400	1	0	0	0	1	0	0	0	0	0	0	0	0	0	0	0	0	0	0	0	0	0	0	0	0	0	0	0
0500	0	0	0	0	0	0	0	0	0	0	0	0	0	0	0	0	0	0	0	0	0	0	0	0	0	0	0	0
0600	1	0	0	0	1	0	0	0	0	0	0	0	0	0	0	0	0	0	0	0	0	0	0	0	0	0	0	0
0700	3	0	0	1	0	2	0	0	0	0	0	0	0	0	0	0	0	0	0	0	0	0	0	0	0	0	0	0
0800	3	0	0	1	0	2	0	0	0	0	0	0	0	0	0	0	0	0	0	0	0	0	0	0	0	0	0	0
0900	9	0	0	2	4	2	1	0	0	0	0	0	0	0	0	0	0	0	0	0	0	0	0	0	0	0	0	0
1000	37	0	2	14	16	5	0	0	0	0	0	0	0	0	0	0	0	0	0	0	0	0	0	0	0	0	0	0
1100	43	0	4	13	17	8	1	0	0	0	0	0	0	0	0	0	0	0	0	0	0	0	0	0	0	0	0	0
1200	49	0	3	20	15	10	1	0	0	0	0	0	0	0	0	0	0	0	0	0	0	0	0	0	0	0	0	0
1300	38	0	2	18	11	7	0	0	0	0	0	0	0	0	0	0	0	0	0	0	0	0	0	0	0	0	0	0
1400	30	0	1	8	10	10	0	1	0	0	0	0	0	0	0	0	0	0	0	0	0	0	0	0	0	0	0	0
1500	30	1	0	9	9	11	0	0	0	0	0	0	0	0	0	0	0	0	0	0	0	0	0	0	0	0	0	0
1600	17	0	0	1	12	3	1	0	0	0	0	0	0	0	0	0	0	0	0	0	0	0	0	0	0	0	0	0
1700	19	0	1	3	12	2	1	0	0	0	0	0	0	0	0	0	0	0	0	0	0	0	0	0	0	0	0	0
1800	15	0	2	0	2	10	1	0	0	0	0	0	0	0	0	0	0	0	0	0	0	0	0	0	0	0	0	0
1900	16	0	0	0	1	13	2	0	0	0	0	0	0	0	0	0	0	0	0	0	0	0	0	0	0	0	0	0
2000	11	0	0	0	4	5	2	0	0	0	0	0	0	0	0	0	0	0	0	0	0	0	0	0	0	0	0	0
2100	15	0	0	1	5	6	2	1	0	0	0	0	0	0	0	0	0	0	0	0	0	0	0	0	0	0	0	0
2200	5	0	0	1	2	1	1	0	0	0	0	0	0	0	0	0	0	0	0	0	0	0	0	0	0	0	0	0
2300	1	0	0	0	0	1	0	0	0	0	0	0	0	0	0	0	0	0	0	0	0	0	0	0	0	0	0	0
07-19	293	1	15	90	108	72	6	1	0	0	0	0	0	0	0	0	0	0	0	0	0	0	0	0	0	0	0	0
06-22	336	1	15	91	119	96	12	2	0	0	0	0	0	0	0	0	0	0	0	0	0	0	0	0	0	0	0	0
06-00	342	1	15	92	121	98	13	2	0	0	0	0	0	0	0	0	0	0	0	0	0	0	0	0	0	0	0	0
00-00	352	1	15	93	124	103	14	2	0	0	0	0	0	0	0	0	0	0	0	0	0	0	0	0	0	0	0	0



Site 1
 Location Access Road, Att - Sign, OSGR: SP 46789 37517
 Direction Westbound

8643 / Bodicote Business Park, Banbury
 September 2018
 Automatic Traffic Count

01 October 2018

Time	Total	Speed Bins (mph)																											
		0 - 5	5 - 10	10 - 15	15 - 20	20 - 25	25 - 30	30 - 35	35 - 40	40 - 45	45 - 50	50 - 55	55 - 60	60 - 65	65 - 70	70 - 75	75 - 80	80 - 85	85 - 90	90 - 95	95 - 100	100 - 105	105 - 110	110 - 115	115 - 120	120 - 125	125 - 130	130 - 135	135 - 140
0000	0	0	0	0	0	0	0	0	0	0	0	0	0	0	0	0	0	0	0	0	0	0	0	0	0	0	0	0	
0100	0	0	0	0	0	0	0	0	0	0	0	0	0	0	0	0	0	0	0	0	0	0	0	0	0	0	0	0	0
0200	0	0	0	0	0	0	0	0	0	0	0	0	0	0	0	0	0	0	0	0	0	0	0	0	0	0	0	0	0
0300	1	0	0	0	0	1	0	0	0	0	0	0	0	0	0	0	0	0	0	0	0	0	0	0	0	0	0	0	0
0400	0	0	0	0	0	0	0	0	0	0	0	0	0	0	0	0	0	0	0	0	0	0	0	0	0	0	0	0	0
0500	0	0	0	0	0	0	0	0	0	0	0	0	0	0	0	0	0	0	0	0	0	0	0	0	0	0	0	0	0
0600	5	0	0	0	2	3	0	0	0	0	0	0	0	0	0	0	0	0	0	0	0	0	0	0	0	0	0	0	0
0700	28	0	0	5	11	11	1	0	0	0	0	0	0	0	0	0	0	0	0	0	0	0	0	0	0	0	0	0	0
0800	34	0	0	5	11	15	3	0	0	0	0	0	0	0	0	0	0	0	0	0	0	0	0	0	0	0	0	0	0
0900	28	0	1	7	12	4	4	0	0	0	0	0	0	0	0	0	0	0	0	0	0	0	0	0	0	0	0	0	0
1000	61	0	2	21	23	12	3	0	0	0	0	0	0	0	0	0	0	0	0	0	0	0	0	0	0	0	0	0	0
1100	64	0	1	16	36	10	1	0	0	0	0	0	0	0	0	0	0	0	0	0	0	0	0	0	0	0	0	0	0
1200	49	0	3	19	22	5	0	0	0	0	0	0	0	0	0	0	0	0	0	0	0	0	0	0	0	0	0	0	0
1300	44	0	0	16	22	6	0	0	0	0	0	0	0	0	0	0	0	0	0	0	0	0	0	0	0	0	0	0	0
1400	43	0	2	12	16	10	3	0	0	0	0	0	0	0	0	0	0	0	0	0	0	0	0	0	0	0	0	0	0
1500	45	0	2	7	27	7	2	0	0	0	0	0	0	0	0	0	0	0	0	0	0	0	0	0	0	0	0	0	0
1600	32	0	0	2	14	13	3	0	0	0	0	0	0	0	0	0	0	0	0	0	0	0	0	0	0	0	0	0	0
1700	38	0	0	3	12	13	9	1	0	0	0	0	0	0	0	0	0	0	0	0	0	0	0	0	0	0	0	0	0
1800	34	0	0	1	10	19	4	0	0	0	0	0	0	0	0	0	0	0	0	0	0	0	0	0	0	0	0	0	0
1900	21	0	0	0	5	12	4	0	0	0	0	0	0	0	0	0	0	0	0	0	0	0	0	0	0	0	0	0	0
2000	10	0	0	0	0	10	0	0	0	0	0	0	0	0	0	0	0	0	0	0	0	0	0	0	0	0	0	0	0
2100	10	0	0	0	5	4	1	0	0	0	0	0	0	0	0	0	0	0	0	0	0	0	0	0	0	0	0	0	0
2200	5	0	0	0	1	3	1	0	0	0	0	0	0	0	0	0	0	0	0	0	0	0	0	0	0	0	0	0	0
2300	1	0	0	0	0	1	0	0	0	0	0	0	0	0	0	0	0	0	0	0	0	0	0	0	0	0	0	0	0
07-19	500	0	11	114	216	125	33	1	0	0	0	0	0	0	0	0	0	0	0	0	0	0	0	0	0	0	0	0	0
06-22	546	0	11	114	228	154	38	1	0	0	0	0	0	0	0	0	0	0	0	0	0	0	0	0	0	0	0	0	0
06-00	552	0	11	114	229	158	39	1	0	0	0	0	0	0	0	0	0	0	0	0	0	0	0	0	0	0	0	0	0
00-00	553	0	11	114	229	159	39	1	0	0	0	0	0	0	0	0	0	0	0	0	0	0	0	0	0	0	0	0	0



Site 1
 Location Access Road, Att - Sign, OSGR: SP 46789 37517
 Direction Westbound

8643 / Bodicote Business Park, Banbury
 September 2018
 Automatic Traffic Count

02 October 2018

Time	Total	Speed Bins (mph)																										
		0 - 5	5 - 10	10 - 15	15 - 20	20 - 25	25 - 30	30 - 35	35 - 40	40 - 45	45 - 50	50 - 55	55 - 60	60 - 65	65 - 70	70 - 75	75 - 80	80 - 85	85 - 90	90 - 95	95 - 100	100 - 105	105 - 110	110 - 115	115 - 120	120 - 125	125 - 130	130 - 135
0000	0	0	0	0	0	0	0	0	0	0	0	0	0	0	0	0	0	0	0	0	0	0	0	0	0	0	0	0
0100	0	0	0	0	0	0	0	0	0	0	0	0	0	0	0	0	0	0	0	0	0	0	0	0	0	0	0	0
0200	0	0	0	0	0	0	0	0	0	0	0	0	0	0	0	0	0	0	0	0	0	0	0	0	0	0	0	0
0300	0	0	0	0	0	0	0	0	0	0	0	0	0	0	0	0	0	0	0	0	0	0	0	0	0	0	0	0
0400	0	0	0	0	0	0	0	0	0	0	0	0	0	0	0	0	0	0	0	0	0	0	0	0	0	0	0	0
0500	1	0	0	0	0	1	0	0	0	0	0	0	0	0	0	0	0	0	0	0	0	0	0	0	0	0	0	0
0600	4	0	0	1	0	3	0	0	0	0	0	0	0	0	0	0	0	0	0	0	0	0	0	0	0	0	0	0
0700	27	0	2	4	12	8	1	0	0	0	0	0	0	0	0	0	0	0	0	0	0	0	0	0	0	0	0	0
0800	37	0	0	16	16	4	1	0	0	0	0	0	0	0	0	0	0	0	0	0	0	0	0	0	0	0	0	0
0900	31	0	2	4	17	5	0	3	0	0	0	0	0	0	0	0	0	0	0	0	0	0	0	0	0	0	0	0
1000	50	0	1	26	20	2	1	0	0	0	0	0	0	0	0	0	0	0	0	0	0	0	0	0	0	0	0	0
1100	43	0	3	12	22	5	1	0	0	0	0	0	0	0	0	0	0	0	0	0	0	0	0	0	0	0	0	0
1200	56	0	2	18	29	7	0	0	0	0	0	0	0	0	0	0	0	0	0	0	0	0	0	0	0	0	0	0
1300	43	0	1	20	15	6	1	0	0	0	0	0	0	0	0	0	0	0	0	0	0	0	0	0	0	0	0	0
1400	47	0	6	20	15	5	1	0	0	0	0	0	0	0	0	0	0	0	0	0	0	0	0	0	0	0	0	0
1500	39	0	2	8	18	10	1	0	0	0	0	0	0	0	0	0	0	0	0	0	0	0	0	0	0	0	0	0
1600	34	0	2	8	9	13	1	1	0	0	0	0	0	0	0	0	0	0	0	0	0	0	0	0	0	0	0	0
1700	30	0	0	2	3	22	3	0	0	0	0	0	0	0	0	0	0	0	0	0	0	0	0	0	0	0	0	0
1800	30	0	0	3	11	14	2	0	0	0	0	0	0	0	0	0	0	0	0	0	0	0	0	0	0	0	0	0
1900	19	0	0	2	3	12	2	0	0	0	0	0	0	0	0	0	0	0	0	0	0	0	0	0	0	0	0	0
2000	19	0	0	0	7	6	5	1	0	0	0	0	0	0	0	0	0	0	0	0	0	0	0	0	0	0	0	0
2100	10	0	0	0	4	4	1	0	1	0	0	0	0	0	0	0	0	0	0	0	0	0	0	0	0	0	0	0
2200	7	0	0	0	2	5	0	0	0	0	0	0	0	0	0	0	0	0	0	0	0	0	0	0	0	0	0	0
2300	0	0	0	0	0	0	0	0	0	0	0	0	0	0	0	0	0	0	0	0	0	0	0	0	0	0	0	0
07-19	467	0	21	141	187	101	13	4	0	0	0	0	0	0	0	0	0	0	0	0	0	0	0	0	0	0	0	0
06-22	519	0	21	144	201	126	21	5	1	0	0	0	0	0	0	0	0	0	0	0	0	0	0	0	0	0	0	0
06-00	526	0	21	144	203	131	21	5	1	0	0	0	0	0	0	0	0	0	0	0	0	0	0	0	0	0	0	0
00-00	527	0	21	144	203	132	21	5	1	0	0	0	0	0	0	0	0	0	0	0	0	0	0	0	0	0	0	0



Site 1
 Location Access Road, Att - Sign, OSGR: SP 46789 37517
 Direction Westbound

8643 / Bodicote Business Park, Banbury
 September 2018
 Automatic Traffic Count

Virtual Day (7)

Time	Total	Speed Bins (mph)																										
		0 - 5	5 - 10	10 - 15	15 - 20	20 - 25	25 - 30	30 - 35	35 - 40	40 - 45	45 - 50	50 - 55	55 - 60	60 - 65	65 - 70	70 - 75	75 - 80	80 - 85	85 - 90	90 - 95	95 - 100	100 - 105	105 - 110	110 - 115	115 - 120	120 - 125	125 - 130	130 - 135
0000	2	0	0	0	0	1	0	0	0	0	0	0	0	0	0	0	0	0	0	0	0	0	0	0	0	0	0	0
0100	0	0	0	0	0	0	0	0	0	0	0	0	0	0	0	0	0	0	0	0	0	0	0	0	0	0	0	0
0200	0	0	0	0	0	0	0	0	0	0	0	0	0	0	0	0	0	0	0	0	0	0	0	0	0	0	0	0
0300	0	0	0	0	0	0	0	0	0	0	0	0	0	0	0	0	0	0	0	0	0	0	0	0	0	0	0	0
0400	1	0	0	0	0	0	0	0	0	0	0	0	0	0	0	0	0	0	0	0	0	0	0	0	0	0	0	0
0500	1	0	0	0	0	0	0	0	0	0	0	0	0	0	0	0	0	0	0	0	0	0	0	0	0	0	0	0
0600	4	0	0	1	1	2	0	0	0	0	0	0	0	0	0	0	0	0	0	0	0	0	0	0	0	0	0	0
0700	22	0	0	2	10	8	1	0	0	0	0	0	0	0	0	0	0	0	0	0	0	0	0	0	0	0	0	0
0800	32	0	0	6	14	9	2	0	0	0	0	0	0	0	0	0	0	0	0	0	0	0	0	0	0	0	0	0
0900	45	0	2	9	26	7	1	0	0	0	0	0	0	0	0	0	0	0	0	0	0	0	0	0	0	0	0	0
1000	58	0	2	22	25	8	1	0	0	0	0	0	0	0	0	0	0	0	0	0	0	0	0	0	0	0	0	0
1100	60	0	3	18	31	7	1	0	0	0	0	0	0	0	0	0	0	0	0	0	0	0	0	0	0	0	0	0
1200	57	0	4	19	22	11	1	0	0	0	0	0	0	0	0	0	0	0	0	0	0	0	0	0	0	0	0	0
1300	52	0	2	17	22	10	1	0	0	0	0	0	0	0	0	0	0	0	0	0	0	0	0	0	0	0	0	0
1400	49	0	3	15	20	9	1	0	0	0	0	0	0	0	0	0	0	0	0	0	0	0	0	0	0	0	0	0
1500	41	0	1	9	20	10	1	0	0	0	0	0	0	0	0	0	0	0	0	0	0	0	0	0	0	0	0	0
1600	37	0	1	5	16	13	2	0	0	0	0	0	0	0	0	0	0	0	0	0	0	0	0	0	0	0	0	0
1700	35	0	1	3	13	14	4	1	0	0	0	0	0	0	0	0	0	0	0	0	0	0	0	0	0	0	0	0
1800	28	0	0	1	10	14	2	0	0	0	0	0	0	0	0	0	0	0	0	0	0	0	0	0	0	0	0	0
1900	21	0	0	2	7	9	3	0	0	0	0	0	0	0	0	0	0	0	0	0	0	0	0	0	0	0	0	0
2000	17	0	0	1	5	9	2	0	0	0	0	0	0	0	0	0	0	0	0	0	0	0	0	0	0	0	0	0
2100	12	0	0	0	5	5	1	0	0	0	0	0	0	0	0	0	0	0	0	0	0	0	0	0	0	0	0	0
2200	8	0	0	0	3	4	1	0	0	0	0	0	0	0	0	0	0	0	0	0	0	0	0	0	0	0	0	0
2300	2	0	0	0	1	1	0	0	0	0	0	0	0	0	0	0	0	0	0	0	0	0	0	0	0	0	0	0
07-19	516	1	19	127	228	120	19	3	0	0	0	0	0	0	0	0	0	0	0	0	0	0	0	0	0	0	0	0
06-22	571	1	19	130	246	145	25	3	0	0	0	0	0	0	0	0	0	0	0	0	0	0	0	0	0	0	0	0
06-00	580	1	19	130	249	150	27	3	0	0	0	0	0	0	0	0	0	0	0	0	0	0	0	0	0	0	0	0
00-00	585	1	19	131	251	152	27	3	0	0	0	0	0	0	0	0	0	0	0	0	0	0	0	0	0	0	0	0



Site 1
 Location Access Road, Att - Sign, OSGR: SP 46789 37517
 Direction Westbound

8643 / Bodicote Business Park, Banbury
 September 2018
 Automatic Traffic Count

Virtual Week (1)

Time	Total	Speed Bins (mph)																											
		0 - 5	5 - 10	10 - 15	15 - 20	20 - 25	25 - 30	30 - 35	35 - 40	40 - 45	45 - 50	50 - 55	55 - 60	60 - 65	65 - 70	70 - 75	75 - 80	80 - 85	85 - 90	90 - 95	95 - 100	100 - 105	105 - 110	110 - 115	115 - 120	120 - 125	125 - 130	130 - 135	135 - 140
Mon	553	0	11	114	229	159	39	1	0	0	0	0	0	0	0	0	0	0	0	0	0	0	0	0	0	0	0	0	0
Tue	527	0	21	144	203	132	21	5	1	0	0	0	0	0	0	0	0	0	0	0	0	0	0	0	0	0	0	0	0
Wed	674	2	32	149	309	153	28	1	0	0	0	0	0	0	0	0	0	0	0	0	0	0	0	0	0	0	0	0	0
Thu	617	1	14	127	262	173	35	5	0	0	0	0	0	0	0	0	0	0	0	0	0	0	0	0	0	0	0	0	0
Fri	714	5	18	166	298	187	35	5	0	0	0	0	0	0	0	0	0	0	0	0	0	0	0	0	0	0	0	0	0
Sat	655	1	22	122	331	156	18	5	0	0	0	0	0	0	0	0	0	0	0	0	0	0	0	0	0	0	0	0	0
Sun	352	1	15	93	124	103	14	2	0	0	0	0	0	0	0	0	0	0	0	0	0	0	0	0	0	0	0	0	0
5 Day Ave.	617	2	19	140	260	161	32	3	0	0	0	0	0	0	0	0	0	0	0	0	0	0	0	0	0	0	0	0	
7 Day Ave.	585	1	19	131	251	152	27	3	0	0	0	0	0	0	0	0	0	0	0	0	0	0	0	0	0	0	0	0	
--	4092	10	133	915	1756	1063	190	24	1	0	0	0	0	0	0	0	0	0	0	0	0	0	0	0	0	0	0	0	

Summary Graphs

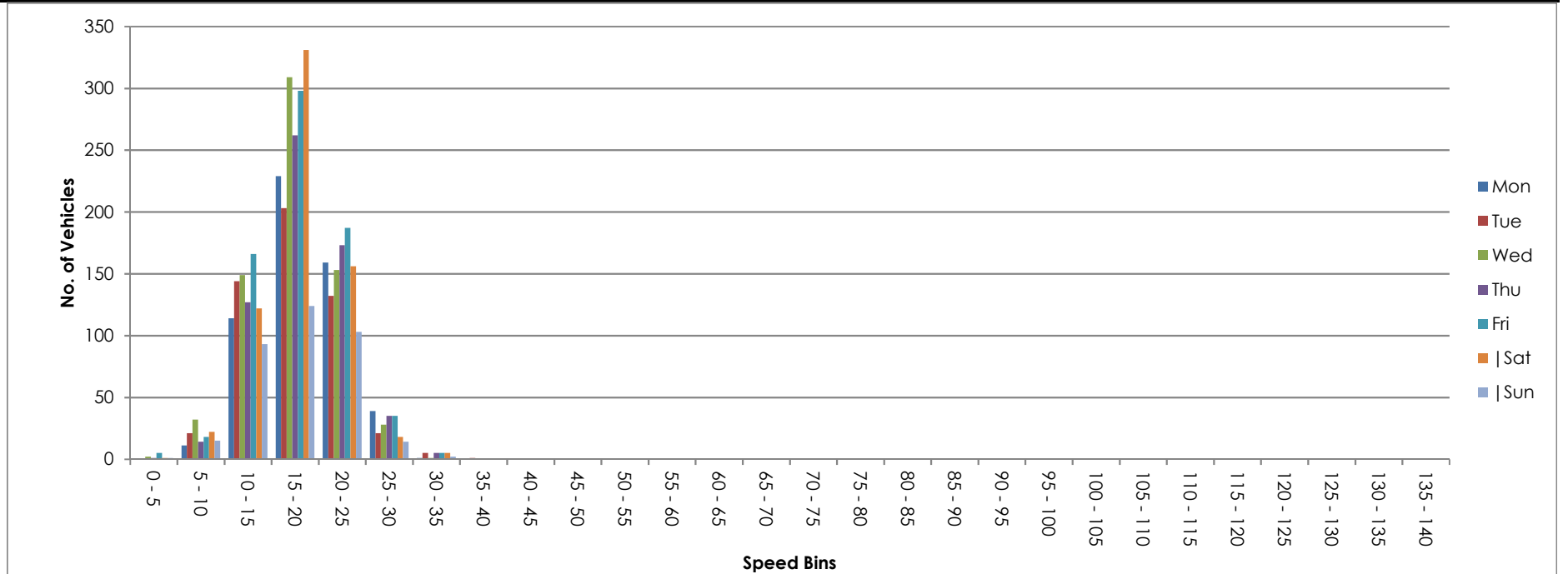

Site 1
 Location Access Road, Att - Sign, OSGR: SP 46789 37517
 Direction Two way

8643 / Bodicote Business Park, Banbury
 September 2018
 Automatic Traffic Count

26 September 2018

Time	Total	Classification												>PSL 30	>PSL% 30	>SL1 35 ACPO	>SL1% 35 ACPO	>SL2 45 DfT	>SL2% 45 DfT	Mean	Vpp 85
		1 MCL	2 SV	3 SVT	4 TB2	5 TB3	6 T4	7 ART3	8 ART4	9 ART5	10 ART6	11 BD	12 DRT								
0000	0	0	0	0	0	0	0	0	0	0	0	0	0	0	0	0	0	0	-	-	
0100	0	0	0	0	0	0	0	0	0	0	0	0	0	0	0	0	0	0	-	-	
0200	0	0	0	0	0	0	0	0	0	0	0	0	0	0	0	0	0	0	-	-	
0300	0	0	0	0	0	0	0	0	0	0	0	0	0	0	0	0	0	0	-	-	
0400	1	0	1	0	0	0	0	0	0	0	0	0	0	0	0	0	0	0	24.5	-	
0500	2	0	1	0	1	0	0	0	0	0	0	0	0	0	0	0	0	0	19.3	-	
0600	23	1	19	0	1	2	0	0	0	0	0	0	0	1	4.3	0	0	0	21.3	26.6	
0700	58	0	56	1	0	0	1	0	0	0	0	0	0	3	5.2	1	1.7	0	21.2	25.1	
0800	64	1	61	0	1	0	1	0	0	0	0	0	0	0	0	0	0	0	21.3	25.1	
0900	92	0	83	0	9	0	0	0	0	0	0	0	0	0	0	0	0	0	16.6	19.9	
1000	96	1	88	0	5	0	0	0	2	0	0	0	0	0	0	0	0	0	16.6	20.4	
1100	115	0	106	0	9	0	0	0	0	0	0	0	0	0	0	0	0	0	13.9	17.2	
1200	135	2	122	0	11	0	0	0	0	0	0	0	0	2	1.5	0	0	0	14.9	18.6	
1300	132	2	121	1	8	0	0	0	0	0	0	0	0	2	1.5	0	0	0	16.4	20.8	
1400	123	0	115	0	8	0	0	0	0	0	0	0	0	0	0	0	0	0	17.4	21.3	
1500	115	0	109	1	5	0	0	0	0	0	0	0	0	1	0.9	0	0	0	18.5	21.9	
1600	93	1	88	1	3	0	0	0	0	0	0	0	0	0	0	0	0	0	17.9	22.4	
1700	97	0	92	0	5	0	0	0	0	0	0	0	0	1	1	0	0	0	18.9	22.8	
1800	83	3	79	0	0	0	1	0	0	0	0	0	0	0	0	0	0	0	19.5	23.3	
1900	55	1	54	0	0	0	0	0	0	0	0	0	0	0	0	0	0	0	20.1	24.4	
2000	36	0	34	0	2	0	0	0	0	0	0	0	0	1	2.8	0	0	0	22.7	25.7	
2100	13	0	13	0	0	0	0	0	0	0	0	0	0	0	0	0	0	0	21.1	23.3	
2200	11	0	11	0	0	0	0	0	0	0	0	0	0	0	0	0	0	0	17.9	21.3	
2300	1	0	1	0	0	0	0	0	0	0	0	0	0	0	0	0	0	0	28	-	
07-19	1203	10	1120	4	64	0	3	0	2	0	0	0	0	9	0.7	1	0.1	0	17.4	22.1	
06-22	1330	12	1240	4	67	2	3	0	2	0	0	0	0	11	0.8	1	0.1	0	17.7	22.6	
06-00	1342	12	1252	4	67	2	3	0	2	0	0	0	0	11	0.8	1	0.1	0	17.7	22.6	
00-00	1345	12	1254	4	68	2	3	0	2	0	0	0	0	11	0.8	1	0.1	0	17.7	22.6	



Site 1
 Location Access Road, Att - Sign, OSGR: SP 46789 37517
 Direction Two way

8643 / Bodicote Business Park, Banbury
 September 2018
 Automatic Traffic Count

27 September 2018

Time	Total	Classification												>PSL 30	>PSL% 30	>SL1 35 ACPO	>SL1% 35 ACPO	>SL2 45 DfT	>SL2% 45 DfT	Mean	Vpp 85
		1 MCL	2 SV	3 SVT	4 TB2	5 TB3	6 T4	7 ART3	8 ART4	9 ART5	10 ART6	11 BD	12 DRT								
0000	0	0	0	0	0	0	0	0	0	0	0	0	0	0	0	0	0	0	-	-	
0100	0	0	0	0	0	0	0	0	0	0	0	0	0	0	0	0	0	0	-	-	
0200	0	0	0	0	0	0	0	0	0	0	0	0	0	0	0	0	0	0	-	-	
0300	0	0	0	0	0	0	0	0	0	0	0	0	0	0	0	0	0	0	-	-	
0400	1	0	1	0	0	0	0	0	0	0	0	0	0	0	0	0	0	0	23.6	-	
0500	2	0	2	0	0	0	0	0	0	0	0	0	0	0	0	0	0	0	21.1	-	
0600	17	0	15	0	1	0	0	1	0	0	0	0	0	0	0	0	0	0	23.2	28	
0700	62	1	59	0	2	0	0	0	0	0	0	0	0	0	0	0	0	0	21.4	25.3	
0800	79	3	70	0	5	1	0	0	0	0	0	0	0	3	3.8	0	0	0	20.8	25.9	
0900	99	2	87	0	7	1	2	0	0	0	0	0	0	0	0	0	0	0	17.7	21.5	
1000	90	0	85	0	4	1	0	0	0	0	0	0	0	1	1.1	0	0	0	16	19.2	
1100	101	1	93	0	5	2	0	0	0	0	0	0	0	1	1	0	0	0	17.3	20.1	
1200	129	2	116	0	11	0	0	0	0	0	0	0	0	2	1.6	1	0.8	0	17.2	21.5	
1300	119	0	107	0	10	1	1	0	0	0	0	0	0	1	0.8	0	0	0	17.5	22.1	
1400	115	0	103	0	10	0	2	0	0	0	0	0	0	0	0	0	0	0	17.4	21.7	
1500	114	1	97	0	9	0	7	0	0	0	0	0	0	0	0	0	0	0	16.8	21.3	
1600	86	1	81	1	2	0	0	0	1	0	0	0	0	3	3.5	0	0	0	19.4	23.7	
1700	77	2	70	0	5	0	0	0	0	0	0	0	0	3	3.9	1	1.3	0	19.7	25.1	
1800	47	0	44	0	3	0	0	0	0	0	0	0	0	0	0	0	0	0	21.6	25.1	
1900	40	0	39	0	1	0	0	0	0	0	0	0	0	0	0	0	0	0	20.8	25.3	
2000	35	0	35	0	0	0	0	0	0	0	0	0	0	2	5.7	1	2.9	0	23.2	27.7	
2100	12	0	12	0	0	0	0	0	0	0	0	0	0	1	8.3	0	0	0	22.4	25.9	
2200	13	0	13	0	0	0	0	0	0	0	0	0	0	0	0	0	0	0	21.8	26.2	
2300	2	0	2	0	0	0	0	0	0	0	0	0	0	0	0	0	0	0	18.5	-	
07-19	1118	13	1012	1	73	6	12	0	1	0	0	0	0	14	1.3	2	0.2	0	18.2	22.6	
06-22	1222	13	1113	1	75	6	12	1	1	0	0	0	0	17	1.4	3	0.2	0	18.5	23.3	
06-00	1237	13	1128	1	75	6	12	1	1	0	0	0	0	17	1.4	3	0.2	0	18.6	23.3	
00-00	1240	13	1131	1	75	6	12	1	1	0	0	0	0	17	1.4	3	0.2	0	18.6	23.3	

Site 1
 Location Access Road, Att - Sign, OSGR: SP 46789 37517
 Direction Two way

8643 / Bodicote Business Park, Banbury
 September 2018
 Automatic Traffic Count

28 September 2018

Time	Total	Classification												>PSL 30	>PSL% 30	>SL1 35 ACPO	>SL1% 35 ACPO	>SL2 45 DfT	>SL2% 45 DfT	Mean	Vpp 85
		1 MCL	2 SV	3 SVT	4 TB2	5 TB3	6 T4	7 ART3	8 ART4	9 ART5	10 ART6	11 BD	12 DRT								
0000	3	0	3	0	0	0	0	0	0	0	0	0	0	0	0	0	0	0	22.3	-	
0100	1	0	1	0	0	0	0	0	0	0	0	0	0	0	0	0	0	0	21.9	-	
0200	1	0	1	0	0	0	0	0	0	0	0	0	0	0	0	0	0	0	19.5	-	
0300	0	0	0	0	0	0	0	0	0	0	0	0	0	0	0	0	0	0	-	-	
0400	2	0	1	0	1	0	0	0	0	0	0	0	0	0	0	0	0	0	27.5	-	
0500	10	0	7	0	3	0	0	0	0	0	0	0	0	0	0	0	0	0	18.6	-	
0600	14	0	14	0	0	0	0	0	0	0	0	0	0	1	7.1	0	0	0	21.9	27.7	
0700	72	0	65	1	4	2	0	0	0	0	0	0	0	3	4.2	0	0	0	20.9	25.3	
0800	91	2	82	1	2	2	2	0	0	0	0	0	0	1	1.1	1	1.1	0	20.1	25.1	
0900	100	0	88	0	7	2	3	0	0	0	0	0	0	0	0	0	0	0	17.6	21.5	
1000	119	0	109	1	5	1	3	0	0	0	0	0	0	0	0	0	0	0	15.7	19	
1100	156	1	147	1	3	1	3	0	0	0	0	0	0	1	0.6	1	0.6	0	0	16.5	19.9
1200	130	0	119	0	10	0	1	0	0	0	0	0	0	3	2.3	1	0.8	0	0	17.4	21.5
1300	142	1	131	0	7	1	2	0	0	0	0	0	0	0	0	0	0	0	0	16.9	22.1
1400	93	3	82	0	8	0	0	0	0	0	0	0	0	1	1.1	0	0	0	0	17.2	22.1
1500	122	1	116	0	5	0	0	0	0	0	0	0	0	0	0	0	0	0	0	17.8	22.4
1600	126	2	115	0	9	0	0	0	0	0	0	0	0	2	1.6	1	0.8	0	0	18.1	21.9
1700	92	3	85	0	4	0	0	0	0	0	0	0	0	3	3.3	0	0	0	0	20	24.2
1800	50	2	47	0	0	1	0	0	0	0	0	0	0	1	2	1	2	0	0	20.8	24.6
1900	39	0	38	0	0	1	0	0	0	0	0	0	0	2	5.1	0	0	0	0	19.6	22.1
2000	32	0	31	0	0	1	0	0	0	0	0	0	0	1	3.1	0	0	0	0	20.2	23
2100	18	0	18	0	0	0	0	0	0	0	0	0	0	0	0	0	0	0	0	19.9	23.9
2200	27	0	27	0	0	0	0	0	0	0	0	0	0	0	0	0	0	0	0	20.3	21.7
2300	7	0	7	0	0	0	0	0	0	0	0	0	0	0	0	0	0	0	0	20.2	-
07-19	1293	15	1186	4	64	10	14	0	0	0	0	0	0	15	1.2	5	0.4	0	0	17.9	22.6
06-22	1396	15	1287	4	64	12	14	0	0	0	0	0	0	19	1.4	5	0.4	0	0	18.1	22.6
06-00	1430	15	1321	4	64	12	14	0	0	0	0	0	0	19	1.3	5	0.3	0	0	18.1	22.8
00-00	1447	15	1334	4	68	12	14	0	0	0	0	0	0	19	1.3	5	0.3	0	0	18.1	22.8



Site 1
 Location Access Road, Att - Sign, OSGR: SP 46789 37517
 Direction Two way

8643 / Bodicote Business Park, Banbury
 September 2018
 Automatic Traffic Count

29 September 2018

Time	Total	Classification												>PSL 30	>PSL% 30	>SL1 35 ACPO	>SL1% 35 ACPO	>SL2 45 DfT	>SL2% 45 DfT	Mean	Vpp 85
		1 MCL	2 SV	3 SVT	4 TB2	5 TB3	6 T4	7 ART3	8 ART4	9 ART5	10 ART6	11 BD	12 DRT								
0000	5	0	5	0	0	0	0	0	0	0	0	0	0	0	0	0	0	0	21	-	
0100	2	0	2	0	0	0	0	0	0	0	0	0	0	0	0	0	0	0	16.3	-	
0200	2	0	0	0	2	0	0	0	0	0	0	0	0	0	0	0	0	0	18	-	
0300	1	0	1	0	0	0	0	0	0	0	0	0	0	0	0	0	0	0	19.6	-	
0400	5	0	5	0	0	0	0	0	0	0	0	0	0	0	0	0	0	0	20	-	
0500	2	0	2	0	0	0	0	0	0	0	0	0	0	0	0	0	0	0	16.6	-	
0600	8	0	7	0	1	0	0	0	0	0	0	0	0	0	0	0	0	0	20.7	-	
0700	17	0	16	0	1	0	0	0	0	0	0	0	0	0	0	0	0	0	19.4	23.3	
0800	63	1	58	0	4	0	0	0	0	0	0	0	0	1	1.6	0	0	0	19.6	24.8	
0900	93	1	85	0	6	0	0	0	0	0	1	0	0	0	0	0	0	0	18.8	22.4	
1000	129	3	118	0	3	0	1	0	0	0	1	2	1	3	2.3	0	0	0	17.5	21.3	
1100	155	7	133	0	6	1	4	0	0	0	3	0	1	2	1.3	0	0	0	17.1	21.7	
1200	123	0	115	0	5	2	1	0	0	0	0	0	0	0	0	0	0	0	16.8	22.1	
1300	99	0	95	0	4	0	0	0	0	0	0	0	0	2	2	0	0	0	17.3	22.1	
1400	130	0	126	2	2	0	0	0	0	0	0	0	0	1	0.8	0	0	0	16.5	20.6	
1500	99	0	90	1	8	0	0	0	0	0	0	0	0	1	1	0	0	0	16.9	21.3	
1600	106	1	92	3	10	0	0	0	0	0	0	0	0	2	1.9	2	1.9	0	18	22.4	
1700	69	0	66	0	3	0	0	0	0	0	0	0	0	1	1.4	0	0	0	19.8	23.9	
1800	63	1	60	0	2	0	0	0	0	0	0	0	0	1	1.6	1	1.6	0	19.3	23.9	
1900	56	1	54	0	1	0	0	0	0	0	0	0	0	1	1.8	0	0	0	19.9	25.9	
2000	31	0	29	0	2	0	0	0	0	0	0	0	0	1	3.2	1	3.2	0	21.2	23.7	
2100	31	0	30	0	1	0	0	0	0	0	0	0	0	1	3.2	1	3.2	0	20.8	23.9	
2200	16	0	16	0	0	0	0	0	0	0	0	0	0	0	0	0	0	0	22.7	25.7	
2300	7	0	7	0	0	0	0	0	0	0	0	0	0	0	0	0	0	0	19.2	-	
07-19	1146	14	1054	6	54	3	6	0	0	0	5	2	2	14	1.2	3	0.3	0	17.7	22.1	
06-22	1272	15	1174	6	59	3	6	0	0	0	5	2	2	17	1.3	5	0.4	0	18	22.4	
06-00	1295	15	1197	6	59	3	6	0	0	0	5	2	2	17	1.3	5	0.4	0	18.1	22.6	
00-00	1312	15	1212	6	61	3	6	0	0	0	5	2	2	17	1.3	5	0.4	0	18.1	22.6	



Site 1
 Location Access Road, Att - Sign, OSGR: SP 46789 37517
 Direction Two way

8643 / Bodicote Business Park, Banbury
 September 2018
 Automatic Traffic Count

30 September 2018

Time	Total	Classification												>PSL 30	>PSL% 30	>SL1 35 ACPO	>SL1% 35 ACPO	>SL2 45 DfT	>SL2% 45 DfT	Mean	Vpp 85
		1 MCL	2 SV	3 SVT	4 TB2	5 TB3	6 T4	7 ART3	8 ART4	9 ART5	10 ART6	11 BD	12 DRT								
0000	8	0	8	0	0	0	0	0	0	0	0	0	0	0	0	0	0	0	21.8	-	
0100	4	0	4	0	0	0	0	0	0	0	0	0	0	0	0	0	0	0	23.6	-	
0200	2	0	2	0	0	0	0	0	0	0	0	0	0	0	0	0	0	0	18.5	-	
0300	0	0	0	0	0	0	0	0	0	0	0	0	0	0	0	0	0	0	-	-	
0400	3	0	3	0	0	0	0	0	0	0	0	0	0	0	0	0	0	0	20.7	-	
0500	1	0	1	0	0	0	0	0	0	0	0	0	0	0	0	0	0	0	20.2	-	
0600	2	0	2	0	0	0	0	0	0	0	0	0	0	0	0	0	0	0	19.8	-	
0700	5	1	4	0	0	0	0	0	0	0	0	0	0	0	0	0	0	0	19.7	-	
0800	9	0	8	1	0	0	0	0	0	0	0	0	0	0	0	0	0	0	21.3	-	
0900	26	0	26	0	0	0	0	0	0	0	0	0	0	0	0	0	0	0	20.1	23.5	
1000	72	0	70	1	0	1	0	0	0	0	0	0	0	0	0	0	0	0	16.1	20.8	
1100	86	0	85	0	0	1	0	0	0	0	0	0	0	0	0	0	0	0	16.9	21.7	
1200	91	0	86	0	3	1	1	0	0	0	0	0	0	0	0	0	0	0	16.1	21.3	
1300	79	0	78	0	1	0	0	0	0	0	0	0	0	1	1.3	0	0	0	16.4	21.5	
1400	65	0	65	0	0	0	0	0	0	0	0	0	0	3	4.6	1	1.5	0	17.9	23	
1500	57	1	53	0	3	0	0	0	0	0	0	0	0	0	0	0	0	0	17.2	23	
1600	31	0	30	0	1	0	0	0	0	0	0	0	0	0	0	0	0	0	19	21.9	
1700	39	1	38	0	0	0	0	0	0	0	0	0	0	1	2.6	0	0	0	19.5	23.3	
1800	27	0	27	0	0	0	0	0	0	0	0	0	0	0	0	0	0	0	20.1	23.9	
1900	23	0	23	0	0	0	0	0	0	0	0	0	0	0	0	0	0	0	22.2	24.8	
2000	20	1	19	0	0	0	0	0	0	0	0	0	0	2	10	0	0	0	22.5	26.4	
2100	23	1	22	0	0	0	0	0	0	0	0	0	0	1	4.3	0	0	0	21.8	26.8	
2200	7	1	6	0	0	0	0	0	0	0	0	0	0	0	0	0	0	0	18.8	-	
2300	1	0	1	0	0	0	0	0	0	0	0	0	0	0	0	0	0	0	22.2	-	
07-19	587	3	570	2	8	3	1	0	0	0	0	0	0	5	0.9	1	0.2	0	0	17.4	22.8
06-22	655	5	636	2	8	3	1	0	0	0	0	0	0	8	1.2	1	0.2	0	0	17.9	23
06-00	663	6	643	2	8	3	1	0	0	0	0	0	0	8	1.2	1	0.2	0	0	17.9	23
00-00	681	6	661	2	8	3	1	0	0	0	0	0	0	8	1.2	1	0.1	0	0	18	23

Site 1
 Location Access Road, Att - Sign, OSGR: SP 46789 37517
 Direction Two way

8643 / Bodicote Business Park, Banbury
 September 2018
 Automatic Traffic Count

01 October 2018

Time	Total	Classification												>PSL 30	>PSL% 30	>SL1 35 ACPO	>SL1% 35 ACPO	>SL2 45 DfT	>SL2% 45 DfT	Mean	Vpp 85
		1 MCL	2 SV	3 SVT	4 TB2	5 TB3	6 T4	7 ART3	8 ART4	9 ART5	10 ART6	11 BD	12 DRT								
0000	1	0	1	0	0	0	0	0	0	0	0	0	0	0	0	0	0	0	23.5	-	
0100	0	0	0	0	0	0	0	0	0	0	0	0	0	0	0	0	0	0	-	-	
0200	0	0	0	0	0	0	0	0	0	0	0	0	0	0	0	0	0	0	-	-	
0300	2	0	2	0	0	0	0	0	0	0	0	0	0	0	0	0	0	0	23.9	-	
0400	2	0	2	0	0	0	0	0	0	0	0	0	0	0	0	0	0	0	21.6	-	
0500	2	0	2	0	0	0	0	0	0	0	0	0	0	0	0	0	0	0	24.8	-	
0600	16	0	14	0	2	0	0	0	0	0	0	0	0	1	6.3	0	0	0	22.2	24.8	
0700	67	1	60	1	2	2	0	0	0	0	1	0	0	0	0	0	0	0	20.1	23.9	
0800	70	1	68	0	0	0	1	0	0	0	0	0	0	2	2.9	0	0	0	21.9	27.3	
0900	52	1	44	0	7	0	0	0	0	0	0	0	0	1	1.9	0	0	0	19.5	25.5	
1000	109	0	103	0	5	0	1	0	0	0	0	0	0	1	0.9	1	0.9	0	17.7	22.1	
1100	118	0	104	0	10	3	1	0	0	0	0	0	0	0	0	0	0	0	16.6	20.4	
1200	94	0	85	0	8	1	0	0	0	0	0	0	0	0	0	0	0	0	16.2	19.5	
1300	93	0	83	1	8	0	1	0	0	0	0	0	0	0	0	0	0	0	16.8	20.6	
1400	84	1	82	1	0	0	0	0	0	0	0	0	0	0	0	0	0	0	17.5	21.9	
1500	101	1	91	2	6	1	0	0	0	0	0	0	0	0	0	0	0	0	17.1	21	
1600	72	0	66	0	5	1	0	0	0	0	0	0	0	3	4.2	1	1.4	0	20.2	23.3	
1700	72	4	66	1	1	0	0	0	0	0	0	0	0	5	6.9	0	0	0	20.7	25.5	
1800	58	1	54	0	2	1	0	0	0	0	0	0	0	1	1.7	0	0	0	21.1	24.6	
1900	39	0	38	1	0	0	0	0	0	0	0	0	0	1	2.6	0	0	0	22.3	25.7	
2000	15	0	15	0	0	0	0	0	0	0	0	0	0	0	0	0	0	0	21	24.2	
2100	16	0	16	0	0	0	0	0	0	0	0	0	0	0	0	0	0	0	21.4	24.4	
2200	6	0	6	0	0	0	0	0	0	0	0	0	0	0	0	0	0	0	22.7	-	
2300	1	0	1	0	0	0	0	0	0	0	0	0	0	0	0	0	0	0	24.5	-	
07-19	990	10	906	6	54	9	4	0	0	0	1	0	0	13	1.3	2	0.2	0	18.4	23.3	
06-22	1076	10	989	7	56	9	4	0	0	0	1	0	0	15	1.4	2	0.2	0	18.7	23.5	
06-00	1083	10	996	7	56	9	4	0	0	0	1	0	0	15	1.4	2	0.2	0	18.7	23.5	
00-00	1090	10	1003	7	56	9	4	0	0	0	1	0	0	15	1.4	2	0.2	0	18.8	23.5	

Site 1
 Location Access Road, Att - Sign, OSGR: SP 46789 37517
 Direction Two way

8643 / Bodicote Business Park, Banbury
 September 2018
 Automatic Traffic Count

02 October 2018

Time	Total	Classification												>PSL 30	>PSL% 30	>SL1 35 ACPO	>SL1% 35 ACPO	>SL2 45 DfT	>SL2% 45 DfT	Mean	Vpp 85
		1 MCL	2 SV	3 SVT	4 TB2	5 TB3	6 T4	7 ART3	8 ART4	9 ART5	10 ART6	11 BD	12 DRT								
0000	1	0	1	0	0	0	0	0	0	0	0	0	0	0	0	0	0	0	17.3	-	
0100	0	0	0	0	0	0	0	0	0	0	0	0	0	0	0	0	0	0	-	-	
0200	0	0	0	0	0	0	0	0	0	0	0	0	0	0	0	0	0	0	-	-	
0300	0	0	0	0	0	0	0	0	0	0	0	0	0	0	0	0	0	0	-	-	
0400	2	0	2	0	0	0	0	0	0	0	0	0	0	0	0	0	0	0	21.4	-	
0500	2	0	2	0	0	0	0	0	0	0	0	0	0	0	0	0	0	0	20.7	-	
0600	14	0	14	0	0	0	0	0	0	0	0	0	0	0	0	0	0	0	21.2	25.1	
0700	60	0	54	0	5	0	0	0	0	0	1	0	0	1	1.7	0	0	0	19.5	23.9	
0800	80	2	73	0	3	0	2	0	0	0	0	0	0	2	2.5	0	0	0	19.6	24.8	
0900	55	0	51	0	3	1	0	0	0	0	0	0	0	3	5.5	0	0	0	17.7	20.8	
1000	90	2	81	0	7	0	0	0	0	0	0	0	0	1	1.1	1	1.1	0	15.5	18.8	
1100	93	3	73	0	14	3	0	0	0	0	0	0	0	0	0	0	0	0	16.5	20.6	
1200	98	0	85	2	11	0	0	0	0	0	0	0	0	1	1	0	0	0	16.8	20.4	
1300	92	0	83	0	8	1	0	0	0	0	0	0	0	2	2.2	1	1.1	0	16.8	20.4	
1400	95	2	78	1	10	3	1	0	0	0	0	0	0	0	0	0	0	0	15.3	19	
1500	92	0	82	0	6	2	1	0	0	1	0	0	0	0	0	0	0	0	16.7	21.5	
1600	80	2	72	1	5	0	0	0	0	0	0	0	0	1	1.3	0	0	0	17.6	22.1	
1700	53	2	47	0	4	0	0	0	0	0	0	0	0	4	7.5	1	1.9	0	22.3	25.1	
1800	49	2	45	0	2	0	0	0	0	0	0	0	0	1	2	0	0	0	21.2	25.3	
1900	34	3	30	0	1	0	0	0	0	0	0	0	0	0	0	0	0	0	20.7	24.8	
2000	28	0	28	0	0	0	0	0	0	0	0	0	0	2	7.1	0	0	0	22.2	26.6	
2100	17	0	17	0	0	0	0	0	0	0	0	0	0	2	11.8	1	5.9	0	22.8	27.7	
2200	10	1	9	0	0	0	0	0	0	0	0	0	0	0	0	0	0	0	20.6	-	
2300	0	0	0	0	0	0	0	0	0	0	0	0	0	0	0	0	0	0	0	0	
07-19	937	15	824	4	78	10	4	0	0	1	1	0	0	16	1.7	3	0.3	0	17.6	22.8	
06-22	1030	18	913	4	79	10	4	0	0	1	1	0	0	20	1.9	4	0.4	0	17.9	23	
06-00	1040	19	922	4	79	10	4	0	0	1	1	0	0	20	1.9	4	0.4	0	18	23	
00-00	1045	19	927	4	79	10	4	0	0	1	1	0	0	20	1.9	4	0.4	0	18	23	



Site 1
 Location Access Road, Att - Sign, OSGR: SP 46789 37517
 Direction Two way

8643 / Bodicote Business Park, Banbury
 September 2018
 Automatic Traffic Count

Virtual Day (7)

Time	Total	Classification												>PSL 30	>PSL% 30	>SL1 35 ACPO	>SL1% 35 ACPO	>SL2 45 DfT	>SL2% 45 DfT	Mean	Vpp 85
		1 MCL	2 SV	3 SVT	4 TB2	5 TB3	6 T4	7 ART3	8 ART4	9 ART5	10 ART6	11 BD	12 DRT								
0000	3	0	3	0	0	0	0	0	0	0	0	0	0	0	0	0	0	0	21.5	-	
0100	1	0	1	0	0	0	0	0	0	0	0	0	0	0	0	0	0	0	21.3	-	
0200	1	0	0	0	0	0	0	0	0	0	0	0	0	0	0	0	0	0	18.5	-	
0300	0	0	0	0	0	0	0	0	0	0	0	0	0	0	0	0	0	0	22.5	-	
0400	2	0	2	0	0	0	0	0	0	0	0	0	0	0	0	0	0	0	22	-	
0500	3	0	2	0	1	0	0	0	0	0	0	0	0	0	0	0	0	0	19.6	-	
0600	13	0	12	0	1	0	0	0	0	0	0	0	0	0	3.2	0	0	0	21.8	26.6	
0700	49	0	45	0	2	1	0	0	0	0	0	0	0	1	2.1	0	0.3	0	20.5	24.6	
0800	65	1	60	0	2	0	1	0	0	0	0	0	0	1	2	0	0.2	0	20.5	25.7	
0900	74	1	66	0	6	1	1	0	0	0	0	0	0	1	0.8	0	0	0	18	22.1	
1000	101	1	93	0	4	0	1	0	0	0	0	0	0	1	0.9	0	0.3	0	16.5	20.6	
1100	118	2	106	0	7	2	1	0	0	0	0	0	0	1	0.5	0	0.1	0	16.4	20.4	
1200	114	1	104	0	8	1	0	0	0	0	0	0	0	1	1	0	0.3	0	16.5	21	
1300	108	0	100	0	7	0	1	0	0	0	0	0	0	1	1.1	0	0.1	0	16.9	21.5	
1400	101	1	93	1	5	0	0	0	0	0	0	0	0	1	0.7	0	0.1	0	17	21.5	
1500	100	1	91	1	6	0	1	0	0	0	0	0	0	0	0.3	0	0	0	17.3	21.9	
1600	85	1	78	1	5	0	0	0	0	0	0	0	0	2	1.9	1	0.7	0	18.5	22.6	
1700	71	2	66	0	3	0	0	0	0	0	0	0	0	3	3.6	0	0.4	0	20	24.8	
1800	54	1	51	0	1	0	0	0	0	0	0	0	0	1	1.1	0	0.5	0	20.4	24.2	
1900	41	1	39	0	0	0	0	0	0	0	0	0	0	1	1.4	0	0	0	20.6	24.8	
2000	28	0	27	0	1	0	0	0	0	0	0	0	0	1	4.6	0	1	0	21.9	25.3	
2100	19	0	18	0	0	0	0	0	0	0	0	0	0	1	3.8	0	1.5	0	21.4	25.5	
2200	13	0	13	0	0	0	0	0	0	0	0	0	0	0	0	0	0	0	20.7	24.4	
2300	3	0	3	0	0	0	0	0	0	0	0	0	0	0	0	0	0	0	20.4	-	
07-19	1039	11	953	4	56	6	6	0	0	0	1	0	0	12	1.2	2	0.2	0	17.8	22.6	
06-22	1140	13	1050	4	58	6	6	0	0	0	1	0	0	15	1.3	3	0.3	0	18.1	22.8	
06-00	1156	13	1066	4	58	6	6	0	0	0	1	0	0	15	1.3	3	0.3	0	18.2	23	
00-00	1166	13	1075	4	59	6	6	0	0	0	1	0	0	15	1.3	3	0.3	0	18.2	23	



Site 1
 Location Access Road, Att - Sign, OSGR: SP 46789 37517
 Direction Two way

8643 / Bodicote Business Park, Banbury
 September 2018
 Automatic Traffic Count

Virtual Week (1)

Time	Total	Classification												>PSL 30	>PSL% 30	>SL1 35 ACPO	>SL1% 35 ACPO	>SL2 45 DfT	>SL2% 45 DfT	Mean	Vpp 85
		1 MCL	2 SV	3 SVT	4 TB2	5 TB3	6 T4	7 ART3	8 ART4	9 ART5	10 ART6	11 BD	12 DRT								
Mon	1090	10	1003	7	56	9	4	0	0	0	1	0	0	15	1.4	2	0.2	0	0	18.8	23.5
Tue	1045	19	927	4	79	10	4	0	0	1	1	0	0	20	1.9	4	0.4	0	0	18	23
Wed	1345	12	1254	4	68	2	3	0	2	0	0	0	0	11	0.8	1	0.1	0	0	17.7	22.6
Thu	1240	13	1131	1	75	6	12	1	1	0	0	0	0	17	1.4	3	0.2	0	0	18.6	23.3
Fri	1447	15	1334	4	68	12	14	0	0	0	0	0	0	19	1.3	5	0.3	0	0	18.1	22.8
Sat	1312	15	1212	6	61	3	6	0	0	0	5	2	2	17	1.3	5	0.4	0	0	18.1	22.6
Sun	681	6	661	2	8	3	1	0	0	0	0	0	0	8	1.2	1	0.1	0	0	18	23
5 Day Ave.	1233	14	1130	4	69	8	7	0	1	0	0	0	0	16	1.3	3	0.2	0	0.0	18.2	23.0
7 Day Ave.	1166	13	1075	4	59	6	6	0	0	0	1	0	0	15	1.3	3	0.3	0	0.0	18.2	23.0
--	8160	90	7522	28	415	45	44	1	3	1	7	2	2	107	1.3	21	0.3	0	0.0	18.2	23.0

Summary Graphs

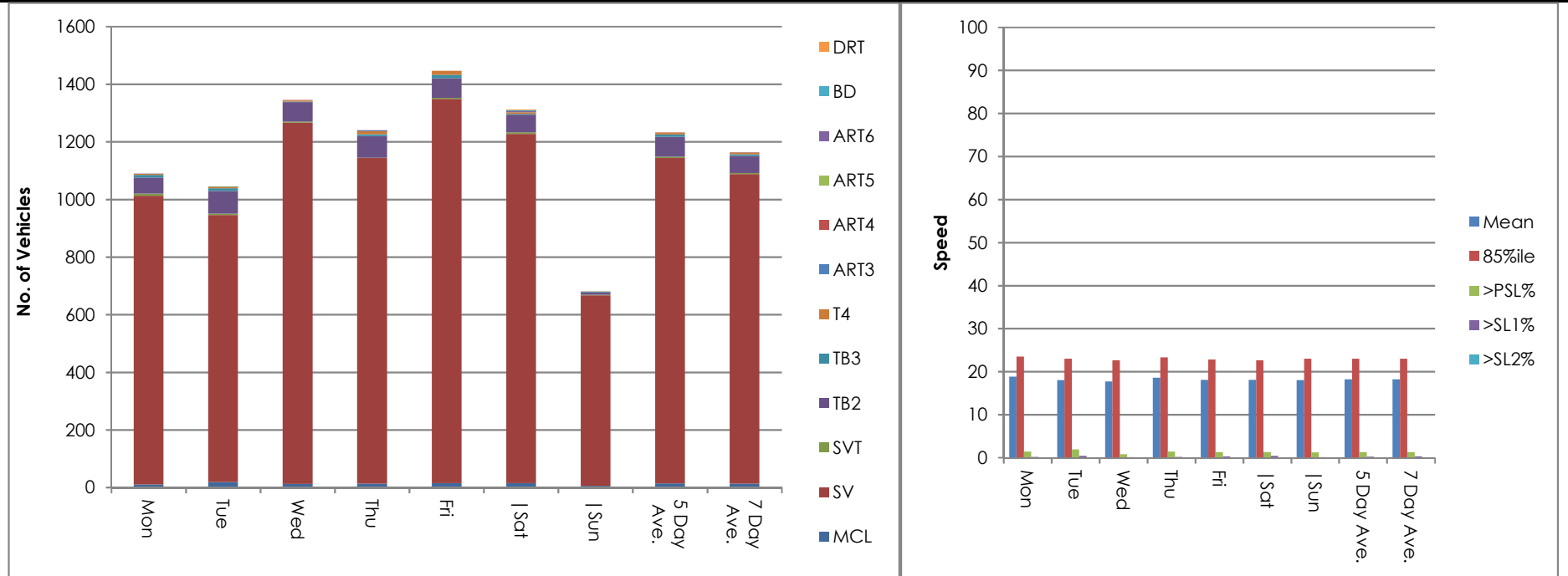

Site 1
 Location Access Road, Att - Sign, OSGR: SP 46789 37517
 Direction Two way

8643 / Bodicote Business Park, Banbury
 September 2018
 Automatic Traffic Count

26 September 2018

Time	Total	Speed Bins (mph)																											
		0 - 5	5 - 10	10 - 15	15 - 20	20 - 25	25 - 30	30 - 35	35 - 40	40 - 45	45 - 50	50 - 55	55 - 60	60 - 65	65 - 70	70 - 75	75 - 80	80 - 85	85 - 90	90 - 95	95 - 100	100 - 105	105 - 110	110 - 115	115 - 120	120 - 125	125 - 130	130 - 135	135 - 140
0000	0	0	0	0	0	0	0	0	0	0	0	0	0	0	0	0	0	0	0	0	0	0	0	0	0	0	0	0	0
0100	0	0	0	0	0	0	0	0	0	0	0	0	0	0	0	0	0	0	0	0	0	0	0	0	0	0	0	0	0
0200	0	0	0	0	0	0	0	0	0	0	0	0	0	0	0	0	0	0	0	0	0	0	0	0	0	0	0	0	0
0300	0	0	0	0	0	0	0	0	0	0	0	0	0	0	0	0	0	0	0	0	0	0	0	0	0	0	0	0	0
0400	1	0	0	0	0	1	0	0	0	0	0	0	0	0	0	0	0	0	0	0	0	0	0	0	0	0	0	0	0
0500	2	0	0	0	1	1	0	0	0	0	0	0	0	0	0	0	0	0	0	0	0	0	0	0	0	0	0	0	0
0600	23	0	0	4	5	10	3	1	0	0	0	0	0	0	0	0	0	0	0	0	0	0	0	0	0	0	0	0	0
0700	58	0	0	3	21	24	7	2	1	0	0	0	0	0	0	0	0	0	0	0	0	0	0	0	0	0	0	0	0
0800	64	0	0	4	19	29	12	0	0	0	0	0	0	0	0	0	0	0	0	0	0	0	0	0	0	0	0	0	0
0900	92	0	2	28	47	12	3	0	0	0	0	0	0	0	0	0	0	0	0	0	0	0	0	0	0	0	0	0	0
1000	96	1	6	22	50	13	4	0	0	0	0	0	0	0	0	0	0	0	0	0	0	0	0	0	0	0	0	0	0
1100	115	0	17	51	41	5	1	0	0	0	0	0	0	0	0	0	0	0	0	0	0	0	0	0	0	0	0	0	0
1200	135	0	21	53	46	11	2	2	0	0	0	0	0	0	0	0	0	0	0	0	0	0	0	0	0	0	0	0	0
1300	132	0	8	45	53	20	4	2	0	0	0	0	0	0	0	0	0	0	0	0	0	0	0	0	0	0	0	0	0
1400	123	0	2	33	56	28	4	0	0	0	0	0	0	0	0	0	0	0	0	0	0	0	0	0	0	0	0	0	0
1500	115	0	2	20	55	30	7	1	0	0	0	0	0	0	0	0	0	0	0	0	0	0	0	0	0	0	0	0	0
1600	93	0	2	24	37	22	8	0	0	0	0	0	0	0	0	0	0	0	0	0	0	0	0	0	0	0	0	0	0
1700	97	0	2	17	40	29	8	1	0	0	0	0	0	0	0	0	0	0	0	0	0	0	0	0	0	0	0	0	0
1800	83	1	3	8	28	35	8	0	0	0	0	0	0	0	0	0	0	0	0	0	0	0	0	0	0	0	0	0	0
1900	55	0	2	5	18	25	5	0	0	0	0	0	0	0	0	0	0	0	0	0	0	0	0	0	0	0	0	0	0
2000	36	0	0	1	6	22	6	1	0	0	0	0	0	0	0	0	0	0	0	0	0	0	0	0	0	0	0	0	0
2100	13	0	0	0	4	8	1	0	0	0	0	0	0	0	0	0	0	0	0	0	0	0	0	0	0	0	0	0	0
2200	11	0	0	2	5	4	0	0	0	0	0	0	0	0	0	0	0	0	0	0	0	0	0	0	0	0	0	0	0
2300	1	0	0	0	0	0	1	0	0	0	0	0	0	0	0	0	0	0	0	0	0	0	0	0	0	0	0	0	0
07-19	1203	2	65	308	493	258	68	8	1	0	0	0	0	0	0	0	0	0	0	0	0	0	0	0	0	0	0	0	0
06-22	1330	2	67	318	526	323	83	10	1	0	0	0	0	0	0	0	0	0	0	0	0	0	0	0	0	0	0	0	0
06-00	1342	2	67	320	531	327	84	10	1	0	0	0	0	0	0	0	0	0	0	0	0	0	0	0	0	0	0	0	0
00-00	1345	2	67	320	532	329	84	10	1	0	0	0	0	0	0	0	0	0	0	0	0	0	0	0	0	0	0	0	0



Site 1
 Location Access Road, Att - Sign, OSGR: SP 46789 37517
 Direction Two way

8643 / Bodicote Business Park, Banbury
 September 2018
 Automatic Traffic Count

27 September 2018

Time	Total	Speed Bins (mph)																											
		0 - 5	5 - 10	10 - 15	15 - 20	20 - 25	25 - 30	30 - 35	35 - 40	40 - 45	45 - 50	50 - 55	55 - 60	60 - 65	65 - 70	70 - 75	75 - 80	80 - 85	85 - 90	90 - 95	95 - 100	100 - 105	105 - 110	110 - 115	115 - 120	120 - 125	125 - 130	130 - 135	135 - 140
0000	0	0	0	0	0	0	0	0	0	0	0	0	0	0	0	0	0	0	0	0	0	0	0	0	0	0	0	0	
0100	0	0	0	0	0	0	0	0	0	0	0	0	0	0	0	0	0	0	0	0	0	0	0	0	0	0	0	0	0
0200	0	0	0	0	0	0	0	0	0	0	0	0	0	0	0	0	0	0	0	0	0	0	0	0	0	0	0	0	0
0300	0	0	0	0	0	0	0	0	0	0	0	0	0	0	0	0	0	0	0	0	0	0	0	0	0	0	0	0	0
0400	1	0	0	0	0	1	0	0	0	0	0	0	0	0	0	0	0	0	0	0	0	0	0	0	0	0	0	0	0
0500	2	0	0	0	1	1	0	0	0	0	0	0	0	0	0	0	0	0	0	0	0	0	0	0	0	0	0	0	0
0600	17	0	1	1	2	6	7	0	0	0	0	0	0	0	0	0	0	0	0	0	0	0	0	0	0	0	0	0	0
0700	62	0	0	3	21	28	10	0	0	0	0	0	0	0	0	0	0	0	0	0	0	0	0	0	0	0	0	0	0
0800	79	0	2	7	22	32	13	3	0	0	0	0	0	0	0	0	0	0	0	0	0	0	0	0	0	0	0	0	0
0900	99	0	4	18	48	24	5	0	0	0	0	0	0	0	0	0	0	0	0	0	0	0	0	0	0	0	0	0	0
1000	90	0	5	28	47	8	1	1	0	0	0	0	0	0	0	0	0	0	0	0	0	0	0	0	0	0	0	0	0
1100	101	0	0	22	58	19	1	1	0	0	0	0	0	0	0	0	0	0	0	0	0	0	0	0	0	0	0	0	0
1200	129	0	6	36	51	32	2	1	1	0	0	0	0	0	0	0	0	0	0	0	0	0	0	0	0	0	0	0	0
1300	119	0	4	34	47	25	8	1	0	0	0	0	0	0	0	0	0	0	0	0	0	0	0	0	0	0	0	0	0
1400	115	0	5	28	51	24	7	0	0	0	0	0	0	0	0	0	0	0	0	0	0	0	0	0	0	0	0	0	0
1500	114	0	7	38	42	23	4	0	0	0	0	0	0	0	0	0	0	0	0	0	0	0	0	0	0	0	0	0	0
1600	86	0	1	14	35	27	6	3	0	0	0	0	0	0	0	0	0	0	0	0	0	0	0	0	0	0	0	0	0
1700	77	0	3	11	28	22	10	2	1	0	0	0	0	0	0	0	0	0	0	0	0	0	0	0	0	0	0	0	0
1800	47	1	0	1	13	24	8	0	0	0	0	0	0	0	0	0	0	0	0	0	0	0	0	0	0	0	0	0	0
1900	40	0	0	3	12	18	7	0	0	0	0	0	0	0	0	0	0	0	0	0	0	0	0	0	0	0	0	0	0
2000	35	0	0	0	8	18	7	1	1	0	0	0	0	0	0	0	0	0	0	0	0	0	0	0	0	0	0	0	0
2100	12	0	0	0	4	5	2	1	0	0	0	0	0	0	0	0	0	0	0	0	0	0	0	0	0	0	0	0	0
2200	13	0	0	0	5	5	3	0	0	0	0	0	0	0	0	0	0	0	0	0	0	0	0	0	0	0	0	0	0
2300	2	0	0	0	2	0	0	0	0	0	0	0	0	0	0	0	0	0	0	0	0	0	0	0	0	0	0	0	0
07-19	1118	1	37	240	463	288	75	12	2	0	0	0	0	0	0	0	0	0	0	0	0	0	0	0	0	0	0	0	0
06-22	1222	1	38	244	489	335	98	14	3	0	0	0	0	0	0	0	0	0	0	0	0	0	0	0	0	0	0	0	0
06-00	1237	1	38	244	496	340	101	14	3	0	0	0	0	0	0	0	0	0	0	0	0	0	0	0	0	0	0	0	0
00-00	1240	1	38	244	497	342	101	14	3	0	0	0	0	0	0	0	0	0	0	0	0	0	0	0	0	0	0	0	0



Site 1
 Location Access Road, Att - Sign, OSGR: SP 46789 37517
 Direction Two way

8643 / Bodicote Business Park, Banbury
 September 2018
 Automatic Traffic Count

28 September 2018

Time	Total	Speed Bins (mph)																										
		0 - 5	5 - 10	10 - 15	15 - 20	20 - 25	25 - 30	30 - 35	35 - 40	40 - 45	45 - 50	50 - 55	55 - 60	60 - 65	65 - 70	70 - 75	75 - 80	80 - 85	85 - 90	90 - 95	95 - 100	100 - 105	105 - 110	110 - 115	115 - 120	120 - 125	125 - 130	130 - 135
0000	3	0	0	0	0	3	0	0	0	0	0	0	0	0	0	0	0	0	0	0	0	0	0	0	0	0	0	0
0100	1	0	0	0	0	1	0	0	0	0	0	0	0	0	0	0	0	0	0	0	0	0	0	0	0	0	0	0
0200	1	0	0	0	1	0	0	0	0	0	0	0	0	0	0	0	0	0	0	0	0	0	0	0	0	0	0	0
0300	0	0	0	0	0	0	0	0	0	0	0	0	0	0	0	0	0	0	0	0	0	0	0	0	0	0	0	0
0400	2	0	0	0	0	0	2	0	0	0	0	0	0	0	0	0	0	0	0	0	0	0	0	0	0	0	0	0
0500	10	1	0	1	4	3	1	0	0	0	0	0	0	0	0	0	0	0	0	0	0	0	0	0	0	0	0	0
0600	14	0	0	0	6	5	2	1	0	0	0	0	0	0	0	0	0	0	0	0	0	0	0	0	0	0	0	0
0700	72	0	1	4	27	27	10	3	0	0	0	0	0	0	0	0	0	0	0	0	0	0	0	0	0	0	0	0
0800	91	0	1	12	29	34	14	0	1	0	0	0	0	0	0	0	0	0	0	0	0	0	0	0	0	0	0	0
0900	100	0	2	19	58	16	5	0	0	0	0	0	0	0	0	0	0	0	0	0	0	0	0	0	0	0	0	0
1000	119	2	4	55	43	15	0	0	0	0	0	0	0	0	0	0	0	0	0	0	0	0	0	0	0	0	0	0
1100	156	0	0	60	72	19	4	0	1	0	0	0	0	0	0	0	0	0	0	0	0	0	0	0	0	0	0	0
1200	130	3	6	32	53	25	8	2	1	0	0	0	0	0	0	0	0	0	0	0	0	0	0	0	0	0	0	0
1300	142	0	8	49	52	27	6	0	0	0	0	0	0	0	0	0	0	0	0	0	0	0	0	0	0	0	0	0
1400	93	0	4	26	37	22	3	1	0	0	0	0	0	0	0	0	0	0	0	0	0	0	0	0	0	0	0	0
1500	122	0	4	26	51	34	7	0	0	0	0	0	0	0	0	0	0	0	0	0	0	0	0	0	0	0	0	0
1600	126	0	3	26	54	36	5	1	1	0	0	0	0	0	0	0	0	0	0	0	0	0	0	0	0	0	0	0
1700	92	0	2	12	34	30	11	3	0	0	0	0	0	0	0	0	0	0	0	0	0	0	0	0	0	0	0	0
1800	50	0	0	6	13	25	5	0	1	0	0	0	0	0	0	0	0	0	0	0	0	0	0	0	0	0	0	0
1900	39	0	0	6	14	16	1	2	0	0	0	0	0	0	0	0	0	0	0	0	0	0	0	0	0	0	0	0
2000	32	0	0	6	8	14	3	1	0	0	0	0	0	0	0	0	0	0	0	0	0	0	0	0	0	0	0	0
2100	18	0	1	1	9	4	3	0	0	0	0	0	0	0	0	0	0	0	0	0	0	0	0	0	0	0	0	0
2200	27	0	0	2	12	10	3	0	0	0	0	0	0	0	0	0	0	0	0	0	0	0	0	0	0	0	0	0
2300	7	0	0	0	5	1	1	0	0	0	0	0	0	0	0	0	0	0	0	0	0	0	0	0	0	0	0	0
07-19	1293	5	35	327	523	310	78	10	5	0	0	0	0	0	0	0	0	0	0	0	0	0	0	0	0	0	0	0
06-22	1396	5	36	340	560	349	87	14	5	0	0	0	0	0	0	0	0	0	0	0	0	0	0	0	0	0	0	0
06-00	1430	5	36	342	577	360	91	14	5	0	0	0	0	0	0	0	0	0	0	0	0	0	0	0	0	0	0	0
00-00	1447	6	36	343	582	367	94	14	5	0	0	0	0	0	0	0	0	0	0	0	0	0	0	0	0	0	0	0



Site 1
 Location Access Road, Att - Sign, OSGR: SP 46789 37517
 Direction Two way

8643 / Bodicote Business Park, Banbury
 September 2018
 Automatic Traffic Count

29 September 2018

Time	Total	Speed Bins (mph)																										
		0 - 5	5 - 10	10 - 15	15 - 20	20 - 25	25 - 30	30 - 35	35 - 40	40 - 45	45 - 50	50 - 55	55 - 60	60 - 65	65 - 70	70 - 75	75 - 80	80 - 85	85 - 90	90 - 95	95 - 100	100 - 105	105 - 110	110 - 115	115 - 120	120 - 125	125 - 130	130 - 135
0000	5	0	0	0	3	1	1	0	0	0	0	0	0	0	0	0	0	0	0	0	0	0	0	0	0	0	0	0
0100	2	0	0	1	1	0	0	0	0	0	0	0	0	0	0	0	0	0	0	0	0	0	0	0	0	0	0	0
0200	2	0	0	0	2	0	0	0	0	0	0	0	0	0	0	0	0	0	0	0	0	0	0	0	0	0	0	0
0300	1	0	0	0	1	0	0	0	0	0	0	0	0	0	0	0	0	0	0	0	0	0	0	0	0	0	0	0
0400	5	0	0	0	2	3	0	0	0	0	0	0	0	0	0	0	0	0	0	0	0	0	0	0	0	0	0	0
0500	2	0	0	1	0	1	0	0	0	0	0	0	0	0	0	0	0	0	0	0	0	0	0	0	0	0	0	0
0600	8	0	0	1	1	6	0	0	0	0	0	0	0	0	0	0	0	0	0	0	0	0	0	0	0	0	0	0
0700	17	0	0	2	8	5	2	0	0	0	0	0	0	0	0	0	0	0	0	0	0	0	0	0	0	0	0	0
0800	63	0	1	9	24	20	8	1	0	0	0	0	0	0	0	0	0	0	0	0	0	0	0	0	0	0	0	0
0900	93	0	4	5	48	31	5	0	0	0	0	0	0	0	0	0	0	0	0	0	0	0	0	0	0	0	0	0
1000	129	0	1	37	58	25	5	3	0	0	0	0	0	0	0	0	0	0	0	0	0	0	0	0	0	0	0	0
1100	155	0	9	41	72	23	8	2	0	0	0	0	0	0	0	0	0	0	0	0	0	0	0	0	0	0	0	0
1200	123	0	12	39	34	34	4	0	0	0	0	0	0	0	0	0	0	0	0	0	0	0	0	0	0	0	0	0
1300	99	0	3	33	39	20	2	2	0	0	0	0	0	0	0	0	0	0	0	0	0	0	0	0	0	0	0	0
1400	130	0	4	51	51	18	5	1	0	0	0	0	0	0	0	0	0	0	0	0	0	0	0	0	0	0	0	0
1500	99	1	1	31	43	22	0	1	0	0	0	0	0	0	0	0	0	0	0	0	0	0	0	0	0	0	0	0
1600	106	0	4	24	47	26	3	0	2	0	0	0	0	0	0	0	0	0	0	0	0	0	0	0	0	0	0	0
1700	69	0	2	6	29	24	7	1	0	0	0	0	0	0	0	0	0	0	0	0	0	0	0	0	0	0	0	0
1800	63	0	1	5	33	20	3	0	1	0	0	0	0	0	0	0	0	0	0	0	0	0	0	0	0	0	0	0
1900	56	0	0	6	28	13	8	1	0	0	0	0	0	0	0	0	0	0	0	0	0	0	0	0	0	0	0	0
2000	31	0	0	0	10	18	2	0	1	0	0	0	0	0	0	0	0	0	0	0	0	0	0	0	0	0	0	0
2100	31	0	1	1	13	11	4	0	1	0	0	0	0	0	0	0	0	0	0	0	0	0	0	0	0	0	0	0
2200	16	0	0	0	4	9	3	0	0	0	0	0	0	0	0	0	0	0	0	0	0	0	0	0	0	0	0	0
2300	7	0	0	1	2	4	0	0	0	0	0	0	0	0	0	0	0	0	0	0	0	0	0	0	0	0	0	0
07-19	1146	1	42	283	486	268	52	11	3	0	0	0	0	0	0	0	0	0	0	0	0	0	0	0	0	0	0	0
06-22	1272	1	43	291	538	316	66	12	5	0	0	0	0	0	0	0	0	0	0	0	0	0	0	0	0	0	0	0
06-00	1295	1	43	292	544	329	69	12	5	0	0	0	0	0	0	0	0	0	0	0	0	0	0	0	0	0	0	0
00-00	1312	1	43	294	553	334	70	12	5	0	0	0	0	0	0	0	0	0	0	0	0	0	0	0	0	0	0	0



Site 1
 Location Access Road, Att - Sign, OSGR: SP 46789 37517
 Direction Two way

8643 / Bodicote Business Park, Banbury
 September 2018
 Automatic Traffic Count

30 September 2018

Time	Total	Speed Bins (mph)																										
		0 - 5	5 - 10	10 - 15	15 - 20	20 - 25	25 - 30	30 - 35	35 - 40	40 - 45	45 - 50	50 - 55	55 - 60	60 - 65	65 - 70	70 - 75	75 - 80	80 - 85	85 - 90	90 - 95	95 - 100	100 - 105	105 - 110	110 - 115	115 - 120	120 - 125	125 - 130	130 - 135
0000	8	0	0	0	2	5	1	0	0	0	0	0	0	0	0	0	0	0	0	0	0	0	0	0	0	0	0	0
0100	4	0	0	0	0	3	1	0	0	0	0	0	0	0	0	0	0	0	0	0	0	0	0	0	0	0	0	0
0200	2	0	0	1	0	1	0	0	0	0	0	0	0	0	0	0	0	0	0	0	0	0	0	0	0	0	0	0
0300	0	0	0	0	0	0	0	0	0	0	0	0	0	0	0	0	0	0	0	0	0	0	0	0	0	0	0	0
0400	3	0	0	0	1	2	0	0	0	0	0	0	0	0	0	0	0	0	0	0	0	0	0	0	0	0	0	0
0500	1	0	0	0	0	1	0	0	0	0	0	0	0	0	0	0	0	0	0	0	0	0	0	0	0	0	0	0
0600	2	0	0	0	1	1	0	0	0	0	0	0	0	0	0	0	0	0	0	0	0	0	0	0	0	0	0	0
0700	5	0	0	1	1	3	0	0	0	0	0	0	0	0	0	0	0	0	0	0	0	0	0	0	0	0	0	0
0800	9	0	0	2	1	4	2	0	0	0	0	0	0	0	0	0	0	0	0	0	0	0	0	0	0	0	0	0
0900	26	0	0	3	9	11	3	0	0	0	0	0	0	0	0	0	0	0	0	0	0	0	0	0	0	0	0	0
1000	72	0	5	26	26	14	1	0	0	0	0	0	0	0	0	0	0	0	0	0	0	0	0	0	0	0	0	0
1100	86	0	6	27	29	18	6	0	0	0	0	0	0	0	0	0	0	0	0	0	0	0	0	0	0	0	0	0
1200	91	0	6	38	27	18	2	0	0	0	0	0	0	0	0	0	0	0	0	0	0	0	0	0	0	0	0	0
1300	79	0	2	36	21	18	1	1	0	0	0	0	0	0	0	0	0	0	0	0	0	0	0	0	0	0	0	0
1400	65	0	4	17	23	18	0	2	1	0	0	0	0	0	0	0	0	0	0	0	0	0	0	0	0	0	0	0
1500	57	1	4	17	17	14	4	0	0	0	0	0	0	0	0	0	0	0	0	0	0	0	0	0	0	0	0	0
1600	31	0	0	3	19	6	3	0	0	0	0	0	0	0	0	0	0	0	0	0	0	0	0	0	0	0	0	0
1700	39	0	2	3	18	10	5	1	0	0	0	0	0	0	0	0	0	0	0	0	0	0	0	0	0	0	0	0
1800	27	0	2	1	8	12	4	0	0	0	0	0	0	0	0	0	0	0	0	0	0	0	0	0	0	0	0	0
1900	23	0	0	0	3	17	3	0	0	0	0	0	0	0	0	0	0	0	0	0	0	0	0	0	0	0	0	0
2000	20	0	0	1	5	10	2	2	0	0	0	0	0	0	0	0	0	0	0	0	0	0	0	0	0	0	0	0
2100	23	0	0	3	7	6	6	1	0	0	0	0	0	0	0	0	0	0	0	0	0	0	0	0	0	0	0	0
2200	7	0	1	1	2	2	1	0	0	0	0	0	0	0	0	0	0	0	0	0	0	0	0	0	0	0	0	0
2300	1	0	0	0	0	1	0	0	0	0	0	0	0	0	0	0	0	0	0	0	0	0	0	0	0	0	0	0
07-19	587	1	31	174	199	146	31	4	1	0	0	0	0	0	0	0	0	0	0	0	0	0	0	0	0	0	0	
06-22	655	1	31	178	215	180	42	7	1	0	0	0	0	0	0	0	0	0	0	0	0	0	0	0	0	0	0	
06-00	663	1	32	179	217	183	43	7	1	0	0	0	0	0	0	0	0	0	0	0	0	0	0	0	0	0	0	
00-00	681	1	32	180	220	195	45	7	1	0	0	0	0	0	0	0	0	0	0	0	0	0	0	0	0	0	0	



Site 1
 Location Access Road, Att - Sign, OSGR: SP 46789 37517
 Direction Two way

8643 / Bodicote Business Park, Banbury
 September 2018
 Automatic Traffic Count

01 October 2018

Time	Total	Speed Bins (mph)																										
		0 - 5	5 - 10	10 - 15	15 - 20	20 - 25	25 - 30	30 - 35	35 - 40	40 - 45	45 - 50	50 - 55	55 - 60	60 - 65	65 - 70	70 - 75	75 - 80	80 - 85	85 - 90	90 - 95	95 - 100	100 - 105	105 - 110	110 - 115	115 - 120	120 - 125	125 - 130	130 - 135
0000	1	0	0	0	0	1	0	0	0	0	0	0	0	0	0	0	0	0	0	0	0	0	0	0	0	0	0	0
0100	0	0	0	0	0	0	0	0	0	0	0	0	0	0	0	0	0	0	0	0	0	0	0	0	0	0	0	0
0200	0	0	0	0	0	0	0	0	0	0	0	0	0	0	0	0	0	0	0	0	0	0	0	0	0	0	0	0
0300	2	0	0	0	0	2	0	0	0	0	0	0	0	0	0	0	0	0	0	0	0	0	0	0	0	0	0	0
0400	2	0	0	0	0	2	0	0	0	0	0	0	0	0	0	0	0	0	0	0	0	0	0	0	0	0	0	0
0500	2	0	0	0	0	1	1	0	0	0	0	0	0	0	0	0	0	0	0	0	0	0	0	0	0	0	0	0
0600	16	0	0	0	3	11	1	1	0	0	0	0	0	0	0	0	0	0	0	0	0	0	0	0	0	0	0	0
0700	67	0	0	7	28	24	8	0	0	0	0	0	0	0	0	0	0	0	0	0	0	0	0	0	0	0	0	0
0800	70	0	0	5	18	29	16	2	0	0	0	0	0	0	0	0	0	0	0	0	0	0	0	0	0	0	0	0
0900	52	0	1	10	18	14	8	1	0	0	0	0	0	0	0	0	0	0	0	0	0	0	0	0	0	0	0	0
1000	109	0	3	34	41	21	9	0	1	0	0	0	0	0	0	0	0	0	0	0	0	0	0	0	0	0	0	0
1100	118	0	2	38	55	21	2	0	0	0	0	0	0	0	0	0	0	0	0	0	0	0	0	0	0	0	0	0
1200	94	0	6	29	47	12	0	0	0	0	0	0	0	0	0	0	0	0	0	0	0	0	0	0	0	0	0	0
1300	93	0	2	33	39	16	3	0	0	0	0	0	0	0	0	0	0	0	0	0	0	0	0	0	0	0	0	0
1400	84	0	5	21	35	17	6	0	0	0	0	0	0	0	0	0	0	0	0	0	0	0	0	0	0	0	0	0
1500	101	0	6	22	52	15	6	0	0	0	0	0	0	0	0	0	0	0	0	0	0	0	0	0	0	0	0	0
1600	72	0	1	6	32	24	6	2	1	0	0	0	0	0	0	0	0	0	0	0	0	0	0	0	0	0	0	0
1700	72	0	0	8	29	19	11	5	0	0	0	0	0	0	0	0	0	0	0	0	0	0	0	0	0	0	0	0
1800	58	0	1	2	19	28	7	1	0	0	0	0	0	0	0	0	0	0	0	0	0	0	0	0	0	0	0	0
1900	39	0	0	1	7	22	8	1	0	0	0	0	0	0	0	0	0	0	0	0	0	0	0	0	0	0	0	0
2000	15	0	0	1	2	12	0	0	0	0	0	0	0	0	0	0	0	0	0	0	0	0	0	0	0	0	0	0
2100	16	0	0	0	6	9	1	0	0	0	0	0	0	0	0	0	0	0	0	0	0	0	0	0	0	0	0	0
2200	6	0	0	0	1	4	1	0	0	0	0	0	0	0	0	0	0	0	0	0	0	0	0	0	0	0	0	0
2300	1	0	0	0	0	1	0	0	0	0	0	0	0	0	0	0	0	0	0	0	0	0	0	0	0	0	0	0
07-19	990	0	27	215	413	240	82	11	2	0	0	0	0	0	0	0	0	0	0	0	0	0	0	0	0	0	0	0
06-22	1076	0	27	217	431	294	92	13	2	0	0	0	0	0	0	0	0	0	0	0	0	0	0	0	0	0	0	0
06-00	1083	0	27	217	432	299	93	13	2	0	0	0	0	0	0	0	0	0	0	0	0	0	0	0	0	0	0	0
00-00	1090	0	27	217	432	305	94	13	2	0	0	0	0	0	0	0	0	0	0	0	0	0	0	0	0	0	0	0



Site 1
 Location Access Road, Att - Sign, OSGR: SP 46789 37517
 Direction Two way

8643 / Bodicote Business Park, Banbury
 September 2018
 Automatic Traffic Count

02 October 2018

Time	Total	Speed Bins (mph)																										
		0 - 5	5 - 10	10 - 15	15 - 20	20 - 25	25 - 30	30 - 35	35 - 40	40 - 45	45 - 50	50 - 55	55 - 60	60 - 65	65 - 70	70 - 75	75 - 80	80 - 85	85 - 90	90 - 95	95 - 100	100 - 105	105 - 110	110 - 115	115 - 120	120 - 125	125 - 130	130 - 135
0000	1	0	0	0	1	0	0	0	0	0	0	0	0	0	0	0	0	0	0	0	0	0	0	0	0	0	0	0
0100	0	0	0	0	0	0	0	0	0	0	0	0	0	0	0	0	0	0	0	0	0	0	0	0	0	0	0	0
0200	0	0	0	0	0	0	0	0	0	0	0	0	0	0	0	0	0	0	0	0	0	0	0	0	0	0	0	0
0300	0	0	0	0	0	0	0	0	0	0	0	0	0	0	0	0	0	0	0	0	0	0	0	0	0	0	0	0
0400	2	0	0	0	1	0	1	0	0	0	0	0	0	0	0	0	0	0	0	0	0	0	0	0	0	0	0	0
0500	2	0	0	0	0	2	0	0	0	0	0	0	0	0	0	0	0	0	0	0	0	0	0	0	0	0	0	0
0600	14	0	0	2	1	8	3	0	0	0	0	0	0	0	0	0	0	0	0	0	0	0	0	0	0	0	0	0
0700	60	0	2	6	24	23	4	1	0	0	0	0	0	0	0	0	0	0	0	0	0	0	0	0	0	0	0	0
0800	80	0	0	19	25	24	10	2	0	0	0	0	0	0	0	0	0	0	0	0	0	0	0	0	0	0	0	0
0900	55	0	2	11	30	8	1	3	0	0	0	0	0	0	0	0	0	0	0	0	0	0	0	0	0	0	0	0
1000	90	0	5	42	34	6	2	0	1	0	0	0	0	0	0	0	0	0	0	0	0	0	0	0	0	0	0	0
1100	93	0	7	24	44	14	4	0	0	0	0	0	0	0	0	0	0	0	0	0	0	0	0	0	0	0	0	0
1200	98	0	4	27	49	15	2	1	0	0	0	0	0	0	0	0	0	0	0	0	0	0	0	0	0	0	0	0
1300	92	0	2	35	37	12	4	1	1	0	0	0	0	0	0	0	0	0	0	0	0	0	0	0	0	0	0	0
1400	95	0	8	37	39	10	1	0	0	0	0	0	0	0	0	0	0	0	0	0	0	0	0	0	0	0	0	0
1500	92	0	7	29	34	17	5	0	0	0	0	0	0	0	0	0	0	0	0	0	0	0	0	0	0	0	0	0
1600	80	0	4	23	27	23	2	1	0	0	0	0	0	0	0	0	0	0	0	0	0	0	0	0	0	0	0	0
1700	53	0	0	4	8	32	5	3	1	0	0	0	0	0	0	0	0	0	0	0	0	0	0	0	0	0	0	0
1800	49	0	0	3	18	20	7	1	0	0	0	0	0	0	0	0	0	0	0	0	0	0	0	0	0	0	0	0
1900	34	0	0	5	8	17	4	0	0	0	0	0	0	0	0	0	0	0	0	0	0	0	0	0	0	0	0	0
2000	28	0	0	0	9	12	5	2	0	0	0	0	0	0	0	0	0	0	0	0	0	0	0	0	0	0	0	0
2100	17	0	0	1	5	7	2	1	1	0	0	0	0	0	0	0	0	0	0	0	0	0	0	0	0	0	0	0
2200	10	0	0	1	3	6	0	0	0	0	0	0	0	0	0	0	0	0	0	0	0	0	0	0	0	0	0	0
2300	0	0	0	0	0	0	0	0	0	0	0	0	0	0	0	0	0	0	0	0	0	0	0	0	0	0	0	0
07-19	937	0	41	260	369	204	47	13	3	0	0	0	0	0	0	0	0	0	0	0	0	0	0	0	0	0	0	0
06-22	1030	0	41	268	392	248	61	16	4	0	0	0	0	0	0	0	0	0	0	0	0	0	0	0	0	0	0	0
06-00	1040	0	41	269	395	254	61	16	4	0	0	0	0	0	0	0	0	0	0	0	0	0	0	0	0	0	0	0
00-00	1045	0	41	269	397	256	62	16	4	0	0	0	0	0	0	0	0	0	0	0	0	0	0	0	0	0	0	0



Site 1
 Location Access Road, Att - Sign, OSGR: SP 46789 37517
 Direction Two way

8643 / Bodicote Business Park, Banbury
 September 2018
 Automatic Traffic Count

Virtual Day (7)

Time	Total	Speed Bins (mph)																										
		0 - 5	5 - 10	10 - 15	15 - 20	20 - 25	25 - 30	30 - 35	35 - 40	40 - 45	45 - 50	50 - 55	55 - 60	60 - 65	65 - 70	70 - 75	75 - 80	80 - 85	85 - 90	90 - 95	95 - 100	100 - 105	105 - 110	110 - 115	115 - 120	120 - 125	125 - 130	130 - 135
0000	3	0	0	0	1	1	0	0	0	0	0	0	0	0	0	0	0	0	0	0	0	0	0	0	0	0	0	0
0100	1	0	0	0	0	1	0	0	0	0	0	0	0	0	0	0	0	0	0	0	0	0	0	0	0	0	0	0
0200	1	0	0	0	0	0	0	0	0	0	0	0	0	0	0	0	0	0	0	0	0	0	0	0	0	0	0	0
0300	0	0	0	0	0	0	0	0	0	0	0	0	0	0	0	0	0	0	0	0	0	0	0	0	0	0	0	0
0400	2	0	0	0	1	1	0	0	0	0	0	0	0	0	0	0	0	0	0	0	0	0	0	0	0	0	0	0
0500	3	0	0	0	1	1	0	0	0	0	0	0	0	0	0	0	0	0	0	0	0	0	0	0	0	0	0	0
0600	13	0	0	1	3	7	2	0	0	0	0	0	0	0	0	0	0	0	0	0	0	0	0	0	0	0	0	0
0700	49	0	0	4	19	19	6	1	0	0	0	0	0	0	0	0	0	0	0	0	0	0	0	0	0	0	0	0
0800	65	0	1	8	20	25	11	1	0	0	0	0	0	0	0	0	0	0	0	0	0	0	0	0	0	0	0	0
0900	74	0	2	13	37	17	4	1	0	0	0	0	0	0	0	0	0	0	0	0	0	0	0	0	0	0	0	0
1000	101	0	4	35	43	15	3	1	0	0	0	0	0	0	0	0	0	0	0	0	0	0	0	0	0	0	0	0
1100	118	0	6	38	53	17	4	0	0	0	0	0	0	0	0	0	0	0	0	0	0	0	0	0	0	0	0	0
1200	114	0	9	36	44	21	3	1	0	0	0	0	0	0	0	0	0	0	0	0	0	0	0	0	0	0	0	0
1300	108	0	4	38	41	20	4	1	0	0	0	0	0	0	0	0	0	0	0	0	0	0	0	0	0	0	0	0
1400	101	0	5	30	42	20	4	1	0	0	0	0	0	0	0	0	0	0	0	0	0	0	0	0	0	0	0	0
1500	100	0	4	26	42	22	5	0	0	0	0	0	0	0	0	0	0	0	0	0	0	0	0	0	0	0	0	0
1600	85	0	2	17	36	23	5	1	1	0	0	0	0	0	0	0	0	0	0	0	0	0	0	0	0	0	0	0
1700	71	0	2	9	27	24	8	2	0	0	0	0	0	0	0	0	0	0	0	0	0	0	0	0	0	0	0	0
1800	54	0	1	4	19	23	6	0	0	0	0	0	0	0	0	0	0	0	0	0	0	0	0	0	0	0	0	0
1900	41	0	0	4	13	18	5	1	0	0	0	0	0	0	0	0	0	0	0	0	0	0	0	0	0	0	0	0
2000	28	0	0	1	7	15	4	1	0	0	0	0	0	0	0	0	0	0	0	0	0	0	0	0	0	0	0	0
2100	19	0	0	1	7	7	3	0	0	0	0	0	0	0	0	0	0	0	0	0	0	0	0	0	0	0	0	0
2200	13	0	0	1	5	6	2	0	0	0	0	0	0	0	0	0	0	0	0	0	0	0	0	0	0	0	0	0
2300	3	0	0	0	1	1	0	0	0	0	0	0	0	0	0	0	0	0	0	0	0	0	0	0	0	0	0	0
07-19	1039	1	40	258	421	245	62	10	2	0	0	0	0	0	0	0	0	0	0	0	0	0	0	0	0	0	0	0
06-22	1140	1	40	265	450	292	76	12	3	0	0	0	0	0	0	0	0	0	0	0	0	0	0	0	0	0	0	0
06-00	1156	1	41	266	456	299	77	12	3	0	0	0	0	0	0	0	0	0	0	0	0	0	0	0	0	0	0	0
00-00	1166	2	41	267	459	304	79	12	3	0	0	0	0	0	0	0	0	0	0	0	0	0	0	0	0	0	0	0



Site 1
 Location Access Road, Att - Sign, OSGR: SP 46789 37517
 Direction Two way

8643 / Bodicote Business Park, Banbury
 September 2018
 Automatic Traffic Count







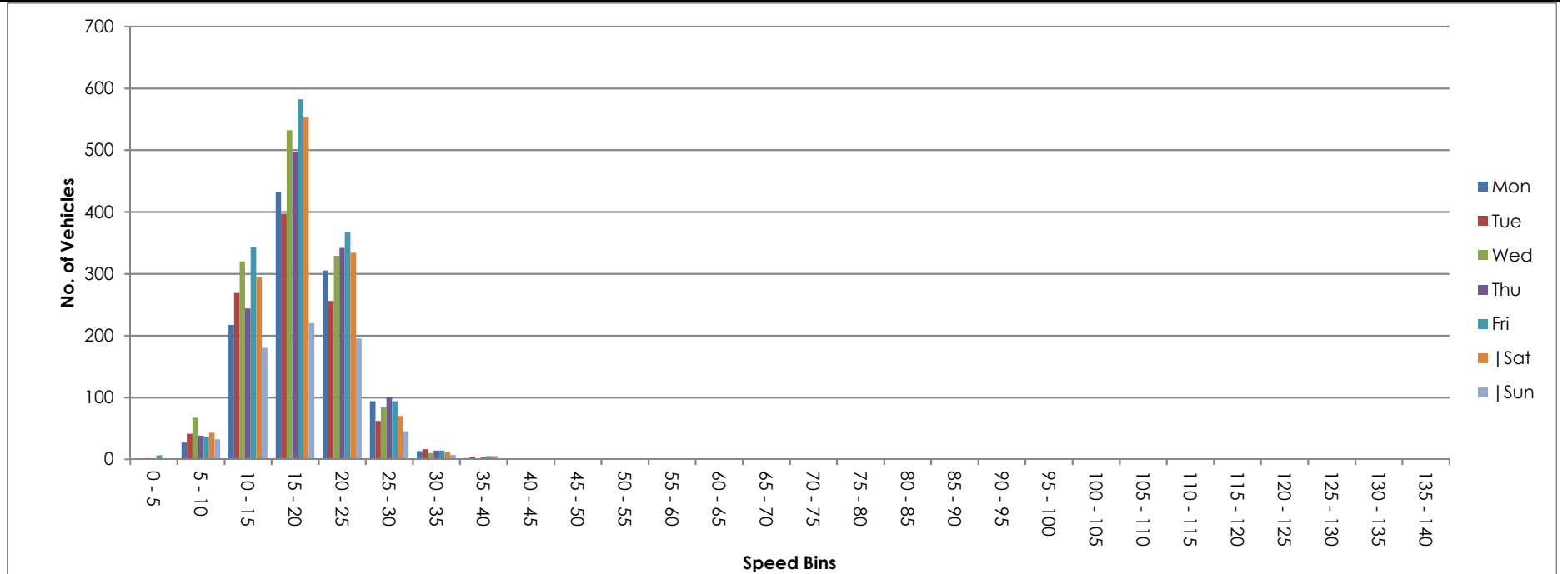



Virtual Week (1)

Time	Total	Speed Bins (mph)																											
		0 - 5	5 - 10	10 - 15	15 - 20	20 - 25	25 - 30	30 - 35	35 - 40	40 - 45	45 - 50	50 - 55	55 - 60	60 - 65	65 - 70	70 - 75	75 - 80	80 - 85	85 - 90	90 - 95	95 - 100	100 - 105	105 - 110	110 - 115	115 - 120	120 - 125	125 - 130	130 - 135	135 - 140
Mon	1090	0	27	217	432	305	94	13	2	0	0	0	0	0	0	0	0	0	0	0	0	0	0	0	0	0	0	0	0
Tue	1045	0	41	269	397	256	62	16	4	0	0	0	0	0	0	0	0	0	0	0	0	0	0	0	0	0	0	0	0
Wed	1345	2	67	320	532	329	84	10	1	0	0	0	0	0	0	0	0	0	0	0	0	0	0	0	0	0	0	0	0
Thu	1240	1	38	244	497	342	101	14	3	0	0	0	0	0	0	0	0	0	0	0	0	0	0	0	0	0	0	0	0
Fri	1447	6	36	343	582	367	94	14	5	0	0	0	0	0	0	0	0	0	0	0	0	0	0	0	0	0	0	0	0
Sat	1312	1	43	294	553	334	70	12	5	0	0	0	0	0	0	0	0	0	0	0	0	0	0	0	0	0	0	0	0
Sun	681	1	32	180	220	195	45	7	1	0	0	0	0	0	0	0	0	0	0	0	0	0	0	0	0	0	0	0	0
5 Day Ave.	1233	2	42	279	488	320	87	13	3	0	0	0	0	0	0	0	0	0	0	0	0	0	0	0	0	0	0	0	0
7 Day Ave.	1166	2	41	267	459	304	79	12	3	0	0	0	0	0	0	0	0	0	0	0	0	0	0	0	0	0	0	0	0
--	8160	11	284	1867	3213	2128	550	86	21	0	0	0	0	0	0	0	0	0	0	0	0	0	0	0	0	0	0	0	0

Summary Graphs



ATC VEHICLE CATEGORIES

Axles	Groups	Description	Class		Parameters	Dominant Vehicle	Aggregate
2	1 or 2	Very Short - Bicycle or Motorcycle	MC	1	$d(1) < 1.7m$ & axles=2		
2	1 or 2	Short - Sedan, Wagon, 4WD, Utility, Light Van	SV	2	$d(1) \geq 1.7m$, $d(1) \leq 3.2m$ & axles=2		
3, 4 or 5	3	Short Towing - Trailer, Caravan, Boat, etc.	SVT	3	groups=3, $d(1) \geq 2.1m$, $d(1) \leq 3.2m$, $d(2) \geq 2.1m$ & axles=3,4,5		1 (Light)
2	2	Two axle truck or Bus	TB2	4	$d(1) > 3.2m$ & axles=2		
3	2	Three axle truck or Bus	TB3	5	axles=3 & groups=2		
>3	2	Four axle truck	T4	6	axles>3 & groups=2		2 (Medium)
3	3	Three axle articulated vehicle or Rigid vehicle and trailer	ART3	7	$d(1) > 3.2m$, axles=3 & groups=3		
4	>2	Four axle articulated vehicle or Rigid vehicle and trailer	ART4	8	$d(2) < 2.1m$ or $d(1) < 2.1m$ or $d(1) > 3.2m$ axles = 4 & groups>2		
5	>2	Five axle articulated vehicle or Rigid vehicle and trailer	ART5	9	$d(2) < 2.1m$ or $d(1) < 2.1m$ or $d(1) > 3.2m$ axles=5 & groups>2		
>=6	>2	Six (or more) axle articulated vehicle or Rigid vehicle and trailer	ART6	10	axles=6 & groups>2 or axles>6 & groups=3		
>6	4	B-Double or Heavy truck and trailer	BD	11	groups=4 & axles>6		
>6	>=5	Double or triple road train or Heavy truck and two (or more) trailers	DRT	12	groups>=5 & axles>6		3 (Heavy)

ATC SPEED BINS & DATA HEADINGS

Heading	Description
0 - 5	Speed bin totals 0 - 5 mph
5 - 10	Speed bin totals 5 - 10 mph
10 - 15	Speed bin totals 10 - 15 mph
15 - 20	Speed bin totals 15 - 20 mph
20 - 25	Speed bin totals 20 - 25 mph
25 - 30	Speed bin totals 25 - 30 mph
30 - 35	Speed bin totals 30 - 35 mph
35 - 40	Speed bin totals 35 - 40 mph
40 - 45	Speed bin totals 40 - 45 mph
45 - 50	Speed bin totals 45 - 50 mph
50 - 55	Speed bin totals 50 - 55 mph
55 - 60	Speed bin totals 55 - 60 mph
60 - 65	Speed bin totals 60 - 65 mph
65 - 70	Speed bin totals 65 - 70 mph
70 - 75	Speed bin totals 70 - 75 mph
75 - 80	Speed bin totals 75 - 80 mph
80 - 85	Speed bin totals 80 - 85 mph
85 - 90	Speed bin totals 85 - 90 mph
90 - 95	Speed bin totals 90 - 95 mph
95 - 100	Speed bin totals 95 - 100 mph
100 - 105	Speed bin totals 100 - 105 mph
105 - 110	Speed bin totals 105 - 110 mph
110 - 115	Speed bin totals 110 - 115 mph
115 - 120	Speed bin totals 115 - 120 mph
120 - 125	Speed bin totals 120 - 125 mph
125 - 130	Speed bin totals 125 - 130 mph
130 - 135	Speed bin totals 130 - 135 mph
135 - 140	Speed bin totals 135 - 140 mph

Heading	Description
>PSL	Greater than the posted speed limit
>PSL%	Greater than the posted speed limit as a percentage
>SL1 ACPO	Greater than ACPO (Association of Chief Police Officers) standard. ACPO is PSL x 10%+2mph
>SL1% ACPO	Greater than ACPO displayed as a percentage
>SL2 DfT	Greater than DfT (Department For Transport) standard. DfT is PSL plus 15mph.
>SL2% DfT	Greater than DfT displayed as a percentage
Mean	Average speed
Vpp 85	85th percentile speed

Site No.	Location.	Direction.	Speed Limit - PSL (mph)	Start Date.	End Date.	Total Vehicles.	5 Day Ave.	7 Day Ave.	No. > Speed Limit.	% > Speed Limit.	No. > ACPO Limit.	% > ACPO Limit.	No. > DfT Limit.	% > DfT Limit.	Mean Speed	85%ile Speed
2	Oxford Road, Att - L/C, OSGR: SP 46884 37469	Northbound	40	26 September 2018	02 October 2018	70273	10900	10039	22205	31.6	4082	5.8	465	0.7	37.7	42.5
		Southbound	40	26 September 2018	02 October 2018	70370	10905	10053	31028	44.1	7875	11.2	1118	1.6	39.6	44.7
		Two way	40	26 September 2018	02 October 2018	140643	21804	20092	53233	37.8	11957	8.5	1583	1.1	38.6	43.6

Site 2
 Location Oxford Road, Att - L/C, OSGR: SP 46884 37469
 Direction Northbound

8643 / Bodicote Business Park, Banbury
 September 2018
 Automatic Traffic Count

26 September 2018

Time	Total	Classification												>PSL 40	>PSL% 40	>SL1 46 ACPO	>SL1% 46 ACPO	>SL2 55 DfT	>SL2% 55 DfT	Mean	Vpp 85
		1 MCL	2 SV	3 SVT	4 TB2	5 TB3	6 T4	7 ART3	8 ART4	9 ART5	10 ART6	11 BD	12 DRT								
0000	29	0	26	0	1	0	0	0	0	1	1	0	0	23	79.3	15	51.7	3	10.3	46.5	53.9
0100	25	0	19	0	6	0	0	0	0	0	0	0	0	20	80	10	40	5	20	46.1	55.5
0200	26	0	21	0	2	0	0	0	1	2	0	0	0	20	76.9	11	42.3	3	11.5	45.4	52.8
0300	29	0	24	0	5	0	0	0	0	0	0	0	0	20	69	14	48.3	6	20.7	46.4	58.2
0400	29	0	16	0	8	0	1	0	0	2	2	0	0	25	86.2	17	58.6	3	10.3	47	52.8
0500	88	1	82	0	4	0	0	0	0	0	1	0	0	56	63.6	22	25	7	8	43.2	50.1
0600	267	5	238	2	16	1	1	0	0	2	1	1	0	130	48.7	42	15.7	6	2.2	40.5	46.1
0700	610	1	540	4	50	3	6	1	0	2	3	0	0	159	26.1	19	3.1	1	0.2	37.1	41.4
0800	839	2	777	2	45	2	4	0	2	1	3	1	0	216	25.7	25	3	0	0	38	41.6
0900	704	5	648	3	43	0	1	0	1	3	0	0	0	166	23.6	18	2.6	0	0	37.6	40.9
1000	651	5	578	2	52	4	3	1	2	1	2	0	1	187	28.7	24	3.7	0	0	38	41.8
1100	584	6	521	3	45	1	5	0	1	1	1	0	0	167	28.6	18	3.1	0	0	37.9	42.1
1200	650	9	572	7	48	4	7	0	3	0	0	0	0	149	22.9	15	2.3	0	0	37.1	41.4
1300	649	3	584	4	44	0	6	0	3	3	2	0	0	201	31	19	2.9	0	0	38.2	42.1
1400	720	9	643	0	56	4	1	0	1	1	5	0	0	210	29.2	17	2.4	0	0	38.1	41.8
1500	724	8	653	3	52	0	2	0	1	3	0	1	1	211	29.1	16	2.2	0	0	37.9	42.1
1600	961	11	863	8	73	3	0	0	0	0	3	0	0	246	25.6	23	2.4	1	0.1	37.3	41.6
1700	1043	5	989	8	33	1	3	0	1	1	2	0	0	193	18.5	26	2.5	4	0.4	35.2	40.3
1800	979	7	925	8	25	2	6	2	1	1	1	0	1	65	6.6	7	0.7	2	0.2	23.6	37.1
1900	513	8	488	0	12	0	2	0	1	1	1	0	0	129	25.1	19	3.7	0	0	37.9	41.2
2000	341	5	318	0	17	0	0	0	0	0	1	0	0	122	35.8	27	7.9	4	1.2	39.1	43.6
2100	236	2	221	0	9	0	2	0	0	2	0	0	0	87	36.9	22	9.3	3	1.3	39.4	44.3
2200	162	2	151	0	5	0	0	0	0	3	1	0	0	91	56.2	32	19.8	10	6.2	42	47.9
2300	94	0	89	0	4	0	0	0	1	0	0	0	0	51	54.3	30	31.9	7	7.4	43.2	50.3
07-19	9114	71	8293	52	566	24	44	4	16	17	22	2	3	2170	23.8	227	2.5	8	0.1	35.9	41.4
06-22	10471	91	9558	54	620	25	49	4	17	22	25	3	3	2638	25.2	337	3.2	21	0.2	36.3	41.6
06-00	10727	93	9798	54	629	25	49	4	18	25	26	3	3	2780	25.9	399	3.7	38	0.4	36.5	41.6
00-00	10953	94	9986	54	655	25	50	4	19	30	30	3	3	2944	26.9	488	4.5	65	0.6	36.6	41.8



Site 2
 Location Oxford Road, Att - L/C, OSGR: SP 46884 37469
 Direction Northbound

8643 / Bodicote Business Park, Banbury
 September 2018
 Automatic Traffic Count

27 September 2018

Time	Total	Classification												>PSL 40	>PSL% 40	>SL1 46 ACPO	>SL1% 46 ACPO	>SL2 55 DfT	>SL2% 55 DfT	Mean	Vpp 85
		1 MCL	2 SV	3 SVT	4 TB2	5 TB3	6 T4	7 ART3	8 ART4	9 ART5	10 ART6	11 BD	12 DRT								
0000	37	1	31	0	2	0	0	0	1	1	1	0	0	28	75.7	15	40.5	9	24.3	47	57.3
0100	21	0	17	0	1	0	0	0	1	2	0	0	0	16	76.2	9	42.9	3	14.3	45.7	54.1
0200	31	0	26	0	3	0	0	0	1	1	0	0	0	27	87.1	15	48.4	4	12.9	46.5	53.7
0300	25	0	19	0	6	0	0	0	0	0	0	0	0	20	80	16	64	6	24	49.2	57.9
0400	20	1	14	0	4	0	0	0	0	0	1	0	0	14	70	7	35	1	5	43.5	48.5
0500	105	0	99	1	5	0	0	0	0	0	0	0	0	63	60	32	30.5	6	5.7	43.2	50.3
0600	234	2	206	0	22	0	0	0	0	2	0	2	0	116	49.6	27	11.5	5	2.1	40.7	45.2
0700	631	7	551	15	48	3	6	0	0	0	0	0	1	210	33.3	36	5.7	1	0.2	37.5	42.7
0800	826	6	761	5	42	4	6	0	0	0	2	0	0	225	27.2	23	2.8	0	0	37.2	41.4
0900	796	4	725	5	46	1	10	0	0	3	2	0	0	143	18	11	1.4	0	0	35.1	40.5
1000	620	3	561	2	45	3	0	0	3	1	2	0	0	207	33.4	27	4.4	0	0	38.7	42.5
1100	594	6	523	3	48	3	4	0	1	3	2	1	0	222	37.4	42	7.1	3	0.5	39.2	43.4
1200	601	4	536	2	46	0	4	3	2	3	1	0	0	275	45.8	43	7.2	4	0.7	39.8	43.8
1300	660	7	586	5	50	3	2	0	0	3	4	0	0	215	32.6	33	5	2	0.3	39	42.7
1400	710	8	627	4	63	3	1	0	1	1	2	0	0	239	33.7	45	6.3	2	0.3	38.3	42.7
1500	753	6	670	5	55	2	12	0	1	0	0	0	2	303	40.2	38	5	2	0.3	38.7	43.2
1600	951	11	842	10	78	3	2	0	3	1	1	0	0	247	26	25	2.6	1	0.1	35.4	41.8
1700	1016	6	949	12	40	0	3	0	2	2	0	1	1	206	20.3	28	2.8	0	0	34.7	40.9
1800	881	16	826	7	26	1	0	0	1	3	1	0	0	245	27.8	20	2.3	1	0.1	37.8	41.6
1900	594	7	560	1	23	0	2	0	1	0	0	0	0	121	20.4	11	1.9	0	0	37.2	40.7
2000	325	2	307	0	15	0	0	0	1	0	0	0	0	117	36	23	7.1	2	0.6	38.9	43.4
2100	224	4	205	1	13	0	0	0	0	1	0	0	0	94	42	25	11.2	2	0.9	39.9	44.1
2200	176	1	165	1	6	0	0	0	1	2	0	0	0	75	42.6	31	17.6	5	2.8	40.9	46.8
2300	69	1	64	0	4	0	0	0	0	0	0	0	0	50	72.5	20	29	5	7.2	43.9	49.4
07-19	9039	84	8157	75	587	26	50	3	14	20	17	2	4	2737	30.3	371	4.1	16	0.2	37.4	42.3
06-22	10416	99	9435	77	660	26	52	3	16	23	17	4	4	3185	30.6	457	4.4	25	0.2	37.5	42.3
06-00	10661	101	9664	78	670	26	52	3	17	25	17	4	4	3310	31	508	4.8	35	0.3	37.6	42.5
00-00	10900	103	9870	79	691	26	52	3	20	29	19	4	4	3478	31.9	602	5.5	64	0.6	37.8	42.5



Site 2
 Location Oxford Road, Att - L/C, OSGR: SP 46884 37469
 Direction Northbound

8643 / Bodicote Business Park, Banbury
 September 2018
 Automatic Traffic Count

28 September 2018

Time	Total	Classification												>PSL 40	>PSL% 40	>SL1 46 ACPO	>SL1% 46 ACPO	>SL2 55 DfT	>SL2% 55 DfT	Mean	Vpp 85
		1 MCL	2 SV	3 SVT	4 TB2	5 TB3	6 T4	7 ART3	8 ART4	9 ART5	10 ART6	11 BD	12 DRT								
0000	44	0	40	0	2	0	0	0	1	0	1	0	0	32	72.7	18	40.9	3	6.8	44.3	50.6
0100	32	1	21	0	5	0	0	0	1	3	1	0	0	21	65.6	12	37.5	0	0	43.6	52.1
0200	37	0	33	0	3	0	0	0	1	0	0	0	0	26	70.3	14	37.8	2	5.4	44.2	49.4
0300	28	0	24	0	4	0	0	0	0	0	0	0	0	23	82.1	16	57.1	5	17.9	47.4	58.2
0400	28	0	18	0	8	0	0	0	1	0	1	0	0	18	64.3	12	42.9	3	10.7	44.5	54.4
0500	105	0	100	0	3	0	0	0	1	1	0	0	0	43	41	17	16.2	2	1.9	39.6	46.3
0600	219	3	188	0	22	1	0	0	1	4	0	0	0	118	53.9	28	12.8	0	0	40.7	45.2
0700	598	4	537	4	47	1	1	1	0	0	2	1	0	199	33.3	40	6.7	4	0.7	38.6	43.2
0800	878	5	798	9	51	3	3	0	0	2	3	3	1	213	24.3	18	2.1	0	0	35.9	41.4
0900	791	2	720	8	54	2	2	0	2	0	1	0	0	107	13.5	18	2.3	0	0	32.5	39.4
1000	709	2	638	5	49	4	3	0	3	2	3	0	0	192	27.1	19	2.7	0	0	38.1	41.6
1100	695	8	614	7	61	0	2	0	0	1	2	0	0	189	27.2	31	4.5	0	0	37.1	41.8
1200	722	12	649	7	46	2	3	0	0	1	2	0	0	216	29.9	25	3.5	0	0	37.8	41.8
1300	766	3	677	0	72	2	2	1	3	4	0	1	1	183	23.9	22	2.9	2	0.3	37.7	41.4
1400	828	5	742	6	63	2	4	0	1	1	4	0	0	229	27.7	29	3.5	0	0	38.1	41.6
1500	911	10	819	6	63	2	4	1	1	1	3	0	1	197	21.6	28	3.1	6	0.7	33.5	40.9
1600	1005	11	921	11	59	0	2	0	0	1	0	0	0	248	24.7	24	2.4	0	0	35.7	41.6
1700	978	4	933	3	31	2	1	2	0	0	2	0	0	332	33.9	32	3.3	0	0	37.6	42.1
1800	935	3	886	5	32	0	1	0	3	4	1	0	0	231	24.7	33	3.5	1	0.1	35.4	41.4
1900	499	2	475	2	16	0	0	0	3	1	0	0	0	125	25.1	22	4.4	0	0	38	41.8
2000	362	5	342	2	12	0	0	0	0	1	0	0	0	158	43.6	42	11.6	1	0.3	39.6	44.7
2100	208	2	192	0	12	0	0	0	1	1	0	0	0	102	49	27	13	5	2.4	40.7	45.2
2200	178	0	167	1	9	0	0	0	0	1	0	0	0	110	61.8	42	23.6	9	5.1	42.7	48.5
2300	98	0	94	0	2	0	0	0	2	0	0	0	0	69	70.4	26	26.5	8	8.2	43.9	50.1
07-19	9816	69	8934	71	628	20	28	5	13	17	23	5	3	2536	25.8	319	3.2	13	0.1	36.4	41.6
06-22	11104	81	10131	75	690	21	28	5	18	24	23	5	3	3039	27.4	438	3.9	19	0.2	36.7	41.8
06-00	11380	81	10392	76	701	21	28	5	20	25	23	5	3	3218	28.3	506	4.4	36	0.3	36.9	42.1
00-00	11654	82	10628	76	726	21	28	5	25	29	26	5	3	3381	29	595	5.1	51	0.4	37	42.3



Site 2
 Location Oxford Road, Att - L/C, OSGR: SP 46884 37469
 Direction Northbound

8643 / Bodicote Business Park, Banbury
 September 2018
 Automatic Traffic Count

29 September 2018

Time	Total	Classification												>PSL 40	>PSL% 40	>SL1 46 ACPO	>SL1% 46 ACPO	>SL2 55 DfT	>SL2% 55 DfT	Mean	Vpp 85
		1 MCL	2 SV	3 SVT	4 TB2	5 TB3	6 T4	7 ART3	8 ART4	9 ART5	10 ART6	11 BD	12 DRT								
0000	66	2	59	0	3	0	0	0	1	1	0	0	0	47	71.2	22	33.3	5	7.6	44.1	51.2
0100	38	0	34	0	4	0	0	0	0	0	0	0	0	29	76.3	21	55.3	3	7.9	45.8	53
0200	39	0	34	0	4	0	0	0	1	0	0	0	0	29	74.4	16	41	7	17.9	46.5	57.5
0300	33	0	25	0	6	0	0	1	0	1	0	0	0	25	75.8	14	42.4	6	18.2	45.7	55.3
0400	24	0	22	0	2	0	0	0	0	0	0	0	0	18	75	14	58.3	6	25	49	57.9
0500	55	1	44	0	8	1	0	0	0	0	1	0	0	38	69.1	19	34.5	7	12.7	45	52.1
0600	82	0	73	0	7	0	2	0	0	0	0	0	0	51	62.2	23	28	2	2.4	42.6	47.9
0700	235	2	215	0	18	0	0	0	0	0	0	0	0	127	54	41	17.4	11	4.7	41.8	47
0800	501	2	462	2	30	2	0	0	1	0	2	0	0	209	41.7	26	5.2	2	0.4	39.2	43.4
0900	689	7	651	3	27	0	1	0	0	0	0	0	0	181	26.3	27	3.9	0	0	37.7	41.6
1000	743	6	699	8	22	1	1	0	1	1	2	0	2	203	27.3	20	2.7	1	0.1	36.9	41.6
1100	681	6	644	4	22	0	3	0	1	1	0	0	0	197	28.9	41	6	2	0.3	38.3	42.1
1200	749	6	707	5	24	5	0	0	0	0	2	0	0	254	33.9	41	5.5	0	0	35.5	42.9
1300	666	10	632	3	21	0	0	0	0	0	0	0	0	241	36.2	49	7.4	1	0.2	38.4	43.2
1400	698	11	655	3	22	0	4	0	1	0	2	0	0	207	29.7	29	4.2	1	0.1	38.4	42.5
1500	644	16	600	6	18	0	4	0	0	0	0	0	0	243	37.7	40	6.2	4	0.6	39.1	43.2
1600	576	12	544	3	16	0	1	0	0	0	0	0	0	251	43.6	50	8.7	4	0.7	39.7	44.3
1700	577	9	548	2	17	0	0	0	1	0	0	0	0	278	48.2	62	10.7	3	0.5	40.5	44.1
1800	466	4	445	1	15	0	0	0	1	0	0	0	0	225	48.3	38	8.2	3	0.6	40.2	44.5
1900	378	1	360	1	16	0	0	0	0	0	0	0	0	162	42.9	29	7.7	5	1.3	39.9	43.6
2000	239	2	224	0	13	0	0	0	0	0	0	0	0	106	44.4	31	13	1	0.4	39.8	45.4
2100	207	1	200	0	6	0	0	0	0	0	0	0	0	89	43	34	16.4	2	1	40.2	46.3
2200	174	1	171	0	2	0	0	0	0	0	0	0	0	102	58.6	35	20.1	3	1.7	41.9	46.5
2300	122	0	118	0	4	0	0	0	0	0	0	0	0	72	59	28	23	7	5.7	42.9	49.9
07-19	7225	91	6802	40	252	8	14	0	6	2	8	0	2	2616	36.2	464	6.4	32	0.4	38.5	43.2
06-22	8131	95	7659	41	294	8	16	0	6	2	8	0	2	3024	37.2	581	7.1	42	0.5	38.7	43.4
06-00	8427	96	7948	41	300	8	16	0	6	2	8	0	2	3198	37.9	644	7.6	52	0.6	38.8	43.6
00-00	8682	99	8166	41	327	9	16	1	8	4	9	0	2	3384	39	750	8.6	86	1	39	43.8



Site 2
 Location Oxford Road, Att - L/C, OSGR: SP 46884 37469
 Direction Northbound

8643 / Bodicote Business Park, Banbury
 September 2018
 Automatic Traffic Count

30 September 2018

Time	Total	Classification												>PSL 40	>PSL% 40	>SL1 46 ACPO	>SL1% 46 ACPO	>SL2 55 DfT	>SL2% 55 DfT	Mean	Vpp 85
		1 MCL	2 SV	3 SVT	4 TB2	5 TB3	6 T4	7 ART3	8 ART4	9 ART5	10 ART6	11 BD	12 DRT								
0000	78	1	67	0	10	0	0	0	0	0	0	0	0	58	74.4	37	47.4	9	11.5	45.3	52.6
0100	68	1	64	0	3	0	0	0	0	0	0	0	0	47	69.1	26	38.2	5	7.4	44.2	52.1
0200	50	1	44	0	4	1	0	0	0	0	0	0	0	36	72	22	44	6	12	45.2	53.2
0300	28	0	23	0	5	0	0	0	0	0	0	0	0	22	78.6	17	60.7	7	25	49.1	60.6
0400	38	2	32	0	4	0	0	0	0	0	0	0	0	32	84.2	23	60.5	8	21.1	48.1	55.7
0500	25	1	23	0	1	0	0	0	0	0	0	0	0	17	68	9	36	4	16	46	53.9
0600	56	0	49	1	6	0	0	0	0	0	0	0	0	34	60.7	16	28.6	2	3.6	42.5	50.3
0700	137	2	124	2	8	1	0	0	0	0	0	0	0	88	64.2	33	24.1	9	6.6	42.9	48.3
0800	245	11	215	1	16	0	1	0	0	0	1	0	0	137	55.9	47	19.2	4	1.6	41.4	47
0900	456	5	428	4	18	0	1	0	0	0	0	0	0	162	35.5	27	5.9	2	0.4	38.4	43.2
1000	663	10	634	3	15	0	1	0	0	0	0	0	0	209	31.5	19	2.9	2	0.3	38	42.1
1100	602	9	568	3	17	2	1	1	0	0	0	0	1	189	31.4	14	2.3	0	0	37.8	42.3
1200	602	16	554	8	19	1	1	0	1	0	1	1	0	182	30.2	25	4.2	0	0	36.7	41.8
1300	607	2	578	2	21	1	1	0	0	1	1	0	0	205	33.8	28	4.6	4	0.7	38.5	42.5
1400	630	23	592	1	9	0	4	0	1	0	0	0	0	231	36.7	36	5.7	3	0.5	38.8	43.2
1500	572	8	550	5	7	0	1	0	0	0	1	0	0	199	34.8	40	7	1	0.2	38.8	42.9
1600	508	13	467	5	20	0	1	0	1	0	1	0	0	225	44.3	43	8.5	4	0.8	39.7	44.1
1700	493	4	467	4	13	0	1	1	3	0	0	0	0	218	44.2	40	8.1	4	0.8	39.6	44.1
1800	399	4	373	2	19	0	1	0	0	0	0	0	0	202	50.6	47	11.8	2	0.5	40.6	45
1900	327	0	312	0	15	0	0	0	0	0	0	0	0	131	40.1	39	11.9	3	0.9	40	44.7
2000	206	0	199	0	7	0	0	0	0	0	0	0	0	94	45.6	30	14.6	6	2.9	41	45.6
2100	158	0	152	0	6	0	0	0	0	0	0	0	0	75	47.5	21	13.3	3	1.9	40.4	45.4
2200	93	0	89	0	4	0	0	0	0	0	0	0	0	41	44.1	23	24.7	6	6.5	41.1	49
2300	51	0	51	0	0	0	0	0	0	0	0	0	0	27	52.9	15	29.4	5	9.8	43.2	51
07-19	5914	107	5550	40	182	5	14	2	6	1	5	1	1	2247	38	399	6.7	35	0.6	38.8	43.4
06-22	6661	107	6262	41	216	5	14	2	6	1	5	1	1	2581	38.7	505	7.6	49	0.7	39	43.6
06-00	6805	107	6402	41	220	5	14	2	6	1	5	1	1	2649	38.9	543	8	60	0.9	39	43.6
00-00	7092	113	6655	41	247	6	14	2	6	1	5	1	1	2861	40.3	677	9.5	99	1.4	39.3	44.1

Site 2
 Location Oxford Road, Att - L/C, OSGR: SP 46884 37469
 Direction Northbound

8643 / Bodicote Business Park, Banbury
 September 2018
 Automatic Traffic Count

01 October 2018

Time	Total	Classification												>PSL 40	>PSL% 40	>SL1 46 ACPO	>SL1% 46 ACPO	>SL2 55 DfT	>SL2% 55 DfT	Mean	Vpp 85
		1 MCL	2 SV	3 SVT	4 TB2	5 TB3	6 T4	7 ART3	8 ART4	9 ART5	10 ART6	11 BD	12 DRT								
0000	22	0	20	0	2	0	0	0	0	0	0	0	0	15	68.2	7	31.8	2	9.1	43.6	51.7
0100	21	0	16	0	5	0	0	0	0	0	0	0	0	17	81	9	42.9	4	19	47.4	56.8
0200	30	2	21	0	3	0	0	0	0	1	3	0	0	19	63.3	13	43.3	2	6.7	43.9	49.9
0300	21	0	14	0	6	0	0	0	0	0	1	0	0	15	71.4	11	52.4	6	28.6	47.5	57.9
0400	27	1	18	0	6	0	0	0	0	1	1	0	0	21	77.8	12	44.4	5	18.5	47.3	55.9
0500	82	0	70	0	10	0	0	0	0	2	0	0	0	49	59.8	17	20.7	4	4.9	42.7	49.7
0600	209	4	185	0	14	0	0	1	0	3	2	0	0	93	44.5	25	12	0	0	40.3	45.4
0700	562	7	511	3	29	1	4	0	3	1	1	1	1	165	29.4	23	4.1	4	0.7	36.9	42.3
0800	743	5	691	4	34	3	3	1	0	0	2	0	0	189	25.4	23	3.1	0	0	37.6	41.8
0900	712	4	655	1	48	1	1	0	0	1	1	0	0	143	20.1	14	2	1	0.1	36.6	40.9
1000	620	3	555	3	50	3	1	0	0	2	3	0	0	163	26.3	11	1.8	1	0.2	37.6	41.2
1100	582	2	503	6	68	1	2	0	0	0	0	0	0	179	30.8	23	4	0	0	38.1	42.1
1200	574	3	521	0	43	1	2	1	1	0	1	0	1	205	35.7	34	5.9	1	0.2	38.7	42.5
1300	670	4	594	5	55	3	2	0	1	2	4	0	0	208	31	26	3.9	2	0.3	38.2	42.3
1400	658	5	587	2	59	3	0	0	0	0	1	0	1	172	26.1	29	4.4	0	0	37.9	42.3
1500	738	1	671	1	58	0	2	1	1	0	3	0	0	250	33.9	28	3.8	1	0.1	38.3	42.5
1600	919	16	842	4	46	4	0	0	1	1	4	1	0	304	33.1	23	2.5	1	0.1	38.6	42.3
1700	1075	9	1007	8	44	3	2	1	0	0	0	1	0	179	16.7	19	1.8	1	0.1	34.1	40
1800	856	8	813	5	26	0	1	0	1	0	2	0	0	188	22	18	2.1	1	0.1	36.6	41.2
1900	515	2	493	0	19	0	0	0	1	0	0	0	0	169	32.8	16	3.1	0	0	38.4	41.8
2000	234	3	222	0	9	0	0	0	0	0	0	0	0	107	45.7	28	12	4	1.7	40.4	45
2100	209	3	196	1	8	0	0	0	0	1	0	0	0	77	36.8	26	12.4	4	1.9	39.1	43.8
2200	143	1	136	0	4	0	0	0	0	2	0	0	0	68	47.6	21	14.7	3	2.1	40.8	45.9
2300	60	1	56	0	1	0	0	0	1	1	0	0	0	35	58.3	16	26.7	2	3.3	42.7	49.9
07-19	8709	67	7950	42	560	23	20	4	8	7	22	3	3	2345	26.9	271	3.1	13	0.1	37.3	41.8
06-22	9876	79	9046	43	610	23	20	5	9	11	24	3	3	2791	28.3	366	3.7	21	0.2	37.5	41.8
06-00	10079	81	9238	43	615	23	20	5	10	14	24	3	3	2894	28.7	403	4	26	0.3	37.6	42.1
00-00	10282	84	9397	43	647	23	20	5	10	18	29	3	3	3030	29.5	472	4.6	49	0.5	37.7	42.3

Site 2
 Location Oxford Road, Att - L/C, OSGR: SP 46884 37469
 Direction Northbound

8643 / Bodicote Business Park, Banbury
 September 2018
 Automatic Traffic Count

02 October 2018

Time	Total	Classification												>PSL 40	>PSL% 40	>SL1 46 ACPO	>SL1% 46 ACPO	>SL2 55 DfT	>SL2% 55 DfT	Mean	Vpp 85
		1 MCL	2 SV	3 SVT	4 TB2	5 TB3	6 T4	7 ART3	8 ART4	9 ART5	10 ART6	11 BD	12 DRT								
0000	35	0	31	0	2	0	0	0	2	0	0	0	0	21	60	11	31.4	3	8.6	44	51.7
0100	21	1	15	0	3	0	0	0	1	0	1	0	0	15	71.4	9	42.9	4	19	45.1	55
0200	30	0	22	0	5	0	0	0	0	3	0	0	0	19	63.3	9	30	5	16.7	44.7	55.3
0300	28	0	22	0	5	0	0	0	0	0	1	0	0	21	75	15	53.6	3	10.7	46.5	51.9
0400	21	0	14	0	7	0	0	0	0	0	0	0	0	15	71.4	9	42.9	5	23.8	46.7	58.4
0500	91	0	84	0	3	1	0	0	1	1	1	0	0	66	72.5	29	31.9	5	5.5	44.1	51
0600	247	4	216	1	19	1	1	0	1	2	2	0	0	115	46.6	25	10.1	2	0.8	39.6	45
0700	620	9	552	2	45	4	3	0	1	3	0	0	1	206	33.2	22	3.5	2	0.3	38.3	42.3
0800	835	6	774	6	42	3	1	0	1	2	0	0	0	168	20.1	21	2.5	1	0.1	35.4	40.7
0900	700	5	617	7	52	4	10	0	1	1	2	0	1	206	29.4	22	3.1	2	0.3	37.3	41.8
1000	629	4	571	2	46	0	2	1	0	1	2	0	0	171	27.2	15	2.4	0	0	37.9	41.6
1100	611	5	533	4	58	4	3	0	2	2	0	0	0	138	22.6	16	2.6	2	0.3	37	40.9
1200	606	1	538	6	48	4	4	0	2	0	2	1	0	192	31.7	28	4.6	0	0	38.1	42.1
1300	649	3	565	7	66	3	3	0	1	1	0	0	0	168	25.9	20	3.1	1	0.2	37.9	41.2
1400	679	5	617	2	46	1	2	0	1	4	0	1	0	234	34.5	27	4	1	0.1	38.7	42.5
1500	772	3	691	4	67	3	1	0	1	1	1	0	0	206	26.7	32	4.1	1	0.1	37.6	41.8
1600	890	11	805	11	61	0	1	0	1	0	0	0	0	236	26.5	28	3.1	1	0.1	37	41.6
1700	1122	11	1037	13	48	2	6	2	1	1	1	0	0	234	20.9	23	2	0	0	34.2	41.2
1800	909	7	856	9	31	1	1	0	1	2	0	0	1	200	22	21	2.3	0	0	37.1	40.9
1900	527	3	504	2	17	0	0	0	1	0	0	0	0	138	26.2	19	3.6	1	0.2	37.7	42.1
2000	299	1	284	1	13	0	0	0	0	0	0	0	0	158	52.8	29	9.7	3	1	40.4	45
2100	199	1	190	0	6	0	1	0	0	1	0	0	0	98	49.2	29	14.6	3	1.5	40.3	45.2
2200	121	3	115	0	3	0	0	0	0	0	0	0	0	72	59.5	27	22.3	4	3.3	42.1	47
2300	69	1	64	0	3	0	0	0	0	1	0	0	0	30	43.5	12	17.4	2	2.9	40.5	47.4
07-19	9022	70	8156	73	610	29	37	3	13	18	8	2	3	2359	26.1	275	3	11	0.1	37	41.6
06-22	10294	79	9350	77	665	30	39	3	15	21	10	2	3	2868	27.9	377	3.7	20	0.2	37.3	41.8
06-00	10484	83	9529	77	671	30	39	3	15	22	10	2	3	2970	28.3	416	4	26	0.2	37.3	42.1
00-00	10710	84	9717	77	696	31	39	3	19	26	13	2	3	3127	29.2	498	4.6	51	0.5	37.5	42.1

Site 2
 Location Oxford Road, Att - L/C, OSGR: SP 46884 37469
 Direction Northbound

8643 / Bodicote Business Park, Banbury
 September 2018
 Automatic Traffic Count

Virtual Day (7)

Time	Total	Classification												>PSL 40	>PSL% 40	>SL1 46 ACPO	>SL1% 46 ACPO	>SL2 55 DfT	>SL2% 55 DfT	Mean	Vpp 85
		1 MCL	2 SV	3 SVT	4 TB2	5 TB3	6 T4	7 ART3	8 ART4	9 ART5	10 ART6	11 BD	12 DRT								
0000	44	1	39	0	3	0	0	0	1	0	0	0	0	32	72	18	40.2	5	10.9	45	52.8
0100	32	0	27	0	4	0	0	0	0	1	0	0	0	24	73	14	42.5	3	10.6	45.1	53
0200	35	0	29	0	3	0	0	0	1	1	0	0	0	25	72.4	14	41.2	4	11.9	45.2	53.5
0300	27	0	22	0	5	0	0	0	0	0	0	0	0	21	76	15	53.6	6	20.3	47.3	57.9
0400	27	1	19	0	6	0	0	0	0	0	1	0	0	20	76.5	13	50.3	4	16.6	46.8	55.9
0500	79	0	72	0	5	0	0	0	0	1	0	0	0	47	60.3	21	26.3	5	6.4	42.9	50.1
0600	188	3	165	1	15	0	1	0	0	2	1	0	0	94	50	27	14.2	2	1.3	40.6	45.6
0700	485	5	433	4	35	2	3	0	1	1	1	0	0	165	34	31	6.3	5	0.9	38.2	42.9
0800	695	5	640	4	37	2	3	0	1	1	2	1	0	194	27.9	26	3.8	1	0.1	37.3	41.8
0900	693	5	635	4	41	1	4	0	1	1	1	0	0	158	22.9	20	2.8	1	0.1	36.3	41.2
1000	662	5	605	4	40	2	2	0	1	1	2	0	0	190	28.7	19	2.9	1	0.1	37.9	41.6
1100	621	6	558	4	46	2	3	0	1	1	1	0	0	183	29.5	26	4.3	1	0.2	37.9	42.3
1200	643	7	582	5	39	2	3	1	1	1	1	0	0	210	32.7	30	4.7	1	0.1	37.6	42.3
1300	667	5	602	4	47	2	2	0	1	2	2	0	0	203	30.4	28	4.2	2	0.3	38.3	42.3
1400	703	9	638	3	45	2	2	0	1	1	2	0	0	217	30.9	30	4.3	1	0.1	38.3	42.3
1500	731	7	665	4	46	1	4	0	1	1	1	0	1	230	31.5	32	4.3	2	0.3	37.5	42.5
1600	830	12	755	7	50	1	1	0	1	0	1	0	0	251	30.2	31	3.7	2	0.2	37.3	42.3
1700	901	7	847	7	32	1	2	1	1	1	1	0	0	234	26	33	3.6	2	0.2	36	41.6
1800	775	7	732	5	25	1	1	0	1	1	1	0	0	194	25	26	3.4	1	0.2	34.9	41.6
1900	479	3	456	1	17	0	1	0	1	0	0	0	0	139	29.1	22	4.6	1	0.3	38.3	42.1
2000	287	3	271	0	12	0	0	0	0	0	0	0	0	123	43	30	10.5	3	1	39.8	44.7
2100	206	2	194	0	9	0	0	0	0	1	0	0	0	89	43.2	26	12.8	3	1.5	40	45
2200	150	1	142	0	5	0	0	0	0	1	0	0	0	80	53.4	30	20.2	6	3.8	41.7	47.4
2300	80	0	77	0	3	0	0	0	1	0	0	0	0	48	59.3	21	26.1	5	6.4	42.9	49.9
07-19	8406	80	7692	56	484	19	30	3	11	12	15	2	3	2430	28.9	332	4	18	0.2	37.2	42.1
06-22	9565	90	8777	58	536	20	31	3	12	15	16	3	3	2875	30.1	437	4.6	28	0.3	37.4	42.3
06-00	9795	92	8996	59	544	20	31	3	13	16	16	3	3	3003	30.7	488	5	39	0.4	37.6	42.3
00-00	10039	94	9203	59	570	20	31	3	15	20	19	3	3	3172	31.6	583	5.8	66	0.7	37.7	42.5



Site 2
 Location Oxford Road, Att - L/C, OSGR: SP 46884 37469
 Direction Northbound

8643 / Bodicote Business Park, Banbury
 September 2018
 Automatic Traffic Count

Virtual Week (1)

Time	Total	Classification												>PSL 40	>PSL% 40	>SL1 46 ACPO	>SL1% 46 ACPO	>SL2 55 DfT	>SL2% 55 DfT	Mean	Vpp 85
		1 MCL	2 SV	3 SVT	4 TB2	5 TB3	6 T4	7 ART3	8 ART4	9 ART5	10 ART6	11 BD	12 DRT								
Mon	10282	84	9397	43	647	23	20	5	10	18	29	3	3	3030	29.5	472	4.6	49	0.5	37.7	42.3
Tue	10710	84	9717	77	696	31	39	3	19	26	13	2	3	3127	29.2	498	4.6	51	0.5	37.5	42.1
Wed	10953	94	9986	54	655	25	50	4	19	30	30	3	3	2944	26.9	488	4.5	65	0.6	36.6	41.8
Thu	10900	103	9870	79	691	26	52	3	20	29	19	4	4	3478	31.9	602	5.5	64	0.6	37.8	42.5
Fri	11654	82	10628	76	726	21	28	5	25	29	26	5	3	3381	29	595	5.1	51	0.4	37	42.3
Sat	8682	99	8166	41	327	9	16	1	8	4	9	0	2	3384	39	750	8.6	86	1	39	43.8
Sun	7092	113	6655	41	247	6	14	2	6	1	5	1	1	2861	40.3	677	9.5	99	1.4	39.3	44.1
5 Day Ave.	10900	89	9920	66	683	25	38	4	19	26	23	3	3	3192	29.3	531	4.9	56	0.5	37.3	42.2
7 Day Ave.	10039	94	9203	59	570	20	31	3	15	20	19	3	3	3172	31.6	583	5.8	66	0.7	37.7	42.5
--	70273	659	64419	411	3989	141	219	23	107	137	131	18	19	22205	31.6	4082	5.8	465	0.7	37.7	42.5

Summary Graphs

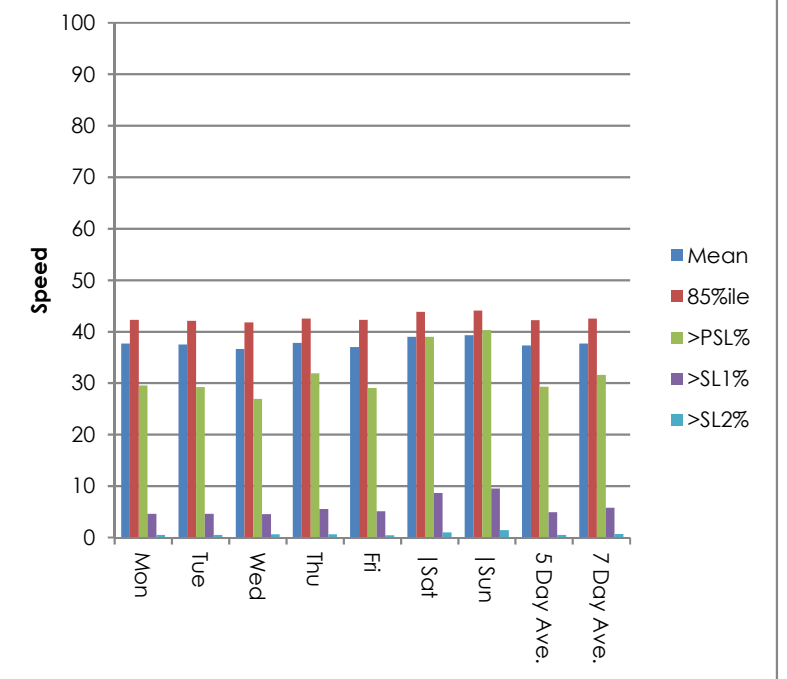
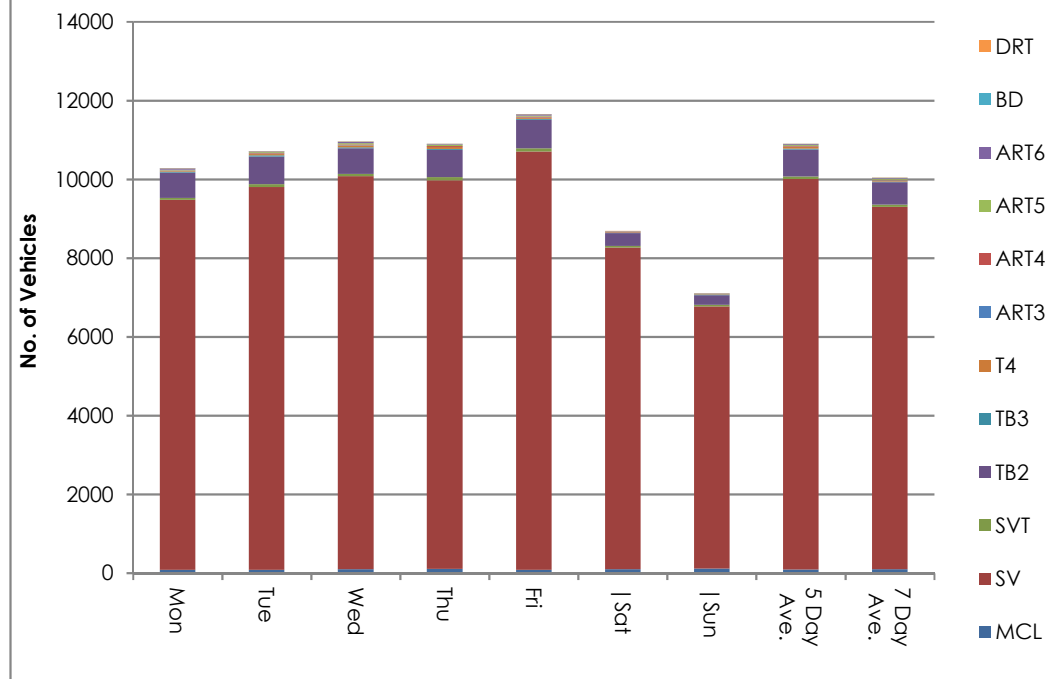

Site 2
 Location Oxford Road, Att - L/C, OSGR: SP 46884 37469
 Direction Northbound

8643 / Bodicote Business Park, Banbury
 September 2018
 Automatic Traffic Count

26 September 2018

Time	Total	Speed Bins (mph)																												
		0 - 5	5 - 10	10 - 15	15 - 20	20 - 25	25 - 30	30 - 35	35 - 40	40 - 45	45 - 50	50 - 55	55 - 60	60 - 65	65 - 70	70 - 75	75 - 80	80 - 85	85 - 90	90 - 95	95 - 100	100 - 105	105 - 110	110 - 115	115 - 120	120 - 125	125 - 130	130 - 135	135 - 140	
0000	29	0	0	0	0	0	0	2	4	6	8	6	1	1	0	1	0	0	0	0	0	0	0	0	0	0	0	0		
0100	25	0	0	0	0	0	0	1	4	10	2	3	3	2	0	0	0	0	0	0	0	0	0	0	0	0	0	0		
0200	26	0	0	0	0	0	0	1	5	8	4	5	3	0	0	0	0	0	0	0	0	0	0	0	0	0	0	0		
0300	29	0	0	0	0	0	0	1	8	5	6	3	4	2	0	0	0	0	0	0	0	0	0	0	0	0	0	0		
0400	29	0	0	0	0	0	0	1	3	7	7	8	1	1	1	0	0	0	0	0	0	0	0	0	0	0	0	0		
0500	88	0	0	0	0	0	0	10	22	31	10	8	4	3	0	0	0	0	0	0	0	0	0	0	0	0	0	0		
0600	267	0	0	0	4	2	3	21	107	74	42	8	3	3	0	0	0	0	0	0	0	0	0	0	0	0	0	0		
0700	610	0	0	0	4	21	34	91	301	133	20	5	1	0	0	0	0	0	0	0	0	0	0	0	0	0	0	0		
0800	839	0	0	0	1	3	11	154	454	177	30	9	0	0	0	0	0	0	0	0	0	0	0	0	0	0	0	0		
0900	704	0	0	0	0	0	11	147	380	138	24	4	0	0	0	0	0	0	0	0	0	0	0	0	0	0	0	0		
1000	651	0	0	0	0	0	13	134	317	154	28	5	0	0	0	0	0	0	0	0	0	0	0	0	0	0	0	0		
1100	584	0	0	1	1	8	16	87	304	141	22	4	0	0	0	0	0	0	0	0	0	0	0	0	0	0	0	0		
1200	650	0	0	0	1	6	30	129	335	130	18	1	0	0	0	0	0	0	0	0	0	0	0	0	0	0	0	0		
1300	649	0	0	0	0	4	13	102	329	171	28	2	0	0	0	0	0	0	0	0	0	0	0	0	0	0	0	0		
1400	720	0	0	0	1	3	17	111	378	179	30	1	0	0	0	0	0	0	0	0	0	0	0	0	0	0	0	0		
1500	724	0	0	0	2	0	10	152	349	182	24	5	0	0	0	0	0	0	0	0	0	0	0	0	0	0	0	0		
1600	961	0	0	0	0	12	46	212	445	205	36	4	1	0	0	0	0	0	0	0	0	0	0	0	0	0	0	0		
1700	1043	0	3	7	23	62	78	245	432	161	22	6	2	0	0	0	0	0	0	0	0	0	0	0	0	0	2	0	0	
1800	979	0	73	255	155	66	63	137	165	54	8	1	0	0	0	2	0	0	0	0	0	0	0	0	0	0	0	0	0	
1900	513	0	0	0	1	0	4	105	274	101	25	3	0	0	0	0	0	0	0	0	0	0	0	0	0	0	0	0	0	
2000	341	0	0	0	0	0	2	58	159	85	25	8	4	0	0	0	0	0	0	0	0	0	0	0	0	0	0	0	0	
2100	236	0	0	0	1	0	2	37	109	59	19	6	3	0	0	0	0	0	0	0	0	0	0	0	0	0	0	0	0	
2200	162	0	0	0	0	0	0	22	49	53	20	8	7	0	2	1	0	0	0	0	0	0	0	0	0	0	0	0	0	
2300	94	0	0	0	0	0	0	5	38	19	17	8	6	0	0	1	0	0	0	0	0	0	0	0	0	0	0	0	0	
07-19	9114	0	76	263	188	185	342	1701	4189	1825	290	47	4	0	0	2	0	0	0	0	0	0	0	0	0	0	0	2	0	0
06-22	10471	0	76	263	194	187	353	1922	4838	2144	401	72	14	3	0	2	0	0	0	0	0	0	0	0	0	0	0	2	0	0
06-00	10727	0	76	263	194	187	353	1949	4925	2216	438	88	27	3	2	4	0	0	0	0	0	0	0	0	0	0	2	0	0	
00-00	10953	0	76	263	194	187	353	1965	4971	2283	475	121	43	12	3	5	0	0	0	0	0	0	0	0	0	0	2	0	0	



Site 2
 Location Oxford Road, Att - L/C, OSGR: SP 46884 37469
 Direction Northbound

8643 / Bodicote Business Park, Banbury
 September 2018
 Automatic Traffic Count

27 September 2018

Time	Total	Speed Bins (mph)																											
		0 - 5	5 - 10	10 - 15	15 - 20	20 - 25	25 - 30	30 - 35	35 - 40	40 - 45	45 - 50	50 - 55	55 - 60	60 - 65	65 - 70	70 - 75	75 - 80	80 - 85	85 - 90	90 - 95	95 - 100	100 - 105	105 - 110	110 - 115	115 - 120	120 - 125	125 - 130	130 - 135	135 - 140
0000	37	0	0	0	0	0	0	1	8	11	4	4	5	2	1	1	0	0	0	0	0	0	0	0	0	0	0	0	0
0100	21	0	0	0	0	0	0	2	3	7	3	3	2	0	1	0	0	0	0	0	0	0	0	0	0	0	0	0	0
0200	31	0	0	0	0	0	1	1	2	9	9	5	2	2	0	0	0	0	0	0	0	0	0	0	0	0	0	0	0
0300	25	0	0	0	0	0	0	1	4	3	5	6	4	2	0	0	0	0	0	0	0	0	0	0	0	0	0	0	0
0400	20	0	0	0	0	0	0	0	6	7	5	1	0	1	0	0	0	0	0	0	0	0	0	0	0	0	0	0	0
0500	105	0	0	0	0	0	0	5	37	31	13	13	3	0	3	0	0	0	0	0	0	0	0	0	0	0	0	0	0
0600	234	0	0	0	1	0	0	22	95	79	24	8	4	1	0	0	0	0	0	0	0	0	0	0	0	0	0	0	0
0700	631	0	0	0	7	26	41	83	264	165	39	5	1	0	0	0	0	0	0	0	0	0	0	0	0	0	0	0	0
0800	826	0	0	0	3	8	59	161	370	189	30	6	0	0	0	0	0	0	0	0	0	0	0	0	0	0	0	0	0
0900	796	0	0	13	37	31	33	173	366	118	21	4	0	0	0	0	0	0	0	0	0	0	0	0	0	0	0	0	0
1000	620	0	0	0	0	0	14	84	315	165	35	7	0	0	0	0	0	0	0	0	0	0	0	0	0	0	0	0	0
1100	594	0	0	0	0	1	9	67	295	167	40	12	3	0	0	0	0	0	0	0	0	0	0	0	0	0	0	0	0
1200	601	0	0	0	1	1	5	64	255	212	51	8	2	2	0	0	0	0	0	0	0	0	0	0	0	0	0	0	0
1300	660	0	0	0	0	1	5	87	352	165	45	3	2	0	0	0	0	0	0	0	0	0	0	0	0	0	0	0	0
1400	710	0	0	0	1	5	37	101	327	184	47	6	2	0	0	0	0	0	0	0	0	0	0	0	0	0	0	0	0
1500	753	0	0	0	2	30	11	62	345	241	54	6	2	0	0	0	0	0	0	0	0	0	0	0	0	0	0	0	0
1600	951	0	11	28	31	32	46	165	391	207	39	0	1	0	0	0	0	0	0	0	0	0	0	0	0	0	0	0	0
1700	1016	0	14	29	34	33	53	249	398	169	30	7	0	0	0	0	0	0	0	0	0	0	0	0	0	0	0	0	0
1800	881	0	0	0	2	1	25	156	452	210	31	3	1	0	0	0	0	0	0	0	0	0	0	0	0	0	0	0	0
1900	594	0	0	0	0	3	6	155	309	104	16	1	0	0	0	0	0	0	0	0	0	0	0	0	0	0	0	0	0
2000	325	0	0	0	0	0	3	63	142	87	23	5	2	0	0	0	0	0	0	0	0	0	0	0	0	0	0	0	0
2100	224	0	0	0	0	0	3	32	95	66	17	9	1	0	0	1	0	0	0	0	0	0	0	0	0	0	0	0	0
2200	176	0	0	0	0	0	0	10	91	40	21	9	2	1	2	0	0	0	0	0	0	0	0	0	0	0	0	0	0
2300	69	0	0	0	0	0	0	5	14	23	19	3	4	1	0	0	0	0	0	0	0	0	0	0	0	0	0	0	0
07-19	9039	0	25	70	118	169	338	1452	4130	2192	462	67	14	2	0	0	0	0	0	0	0	0	0	0	0	0	0	0	0
06-22	10416	0	25	70	119	172	350	1724	4771	2528	542	90	21	3	0	1	0	0	0	0	0	0	0	0	0	0	0	0	0
06-00	10661	0	25	70	119	172	350	1739	4876	2591	582	102	27	5	2	1	0	0	0	0	0	0	0	0	0	0	0	0	0
00-00	10900	0	25	70	119	172	351	1749	4936	2659	621	134	43	12	7	2	0	0	0	0	0	0	0	0	0	0	0	0	0



Site 2
 Location Oxford Road, Att - L/C, OSGR: SP 46884 37469
 Direction Northbound

8643 / Bodicote Business Park, Banbury
 September 2018
 Automatic Traffic Count

28 September 2018

Time	Total	Speed Bins (mph)																											
		0 - 5	5 - 10	10 - 15	15 - 20	20 - 25	25 - 30	30 - 35	35 - 40	40 - 45	45 - 50	50 - 55	55 - 60	60 - 65	65 - 70	70 - 75	75 - 80	80 - 85	85 - 90	90 - 95	95 - 100	100 - 105	105 - 110	110 - 115	115 - 120	120 - 125	125 - 130	130 - 135	135 - 140
0000	44	0	0	0	0	0	2	1	9	10	14	5	2	1	0	0	0	0	0	0	0	0	0	0	0	0	0	0	
0100	32	0	0	0	0	0	0	4	7	8	4	9	0	0	0	0	0	0	0	0	0	0	0	0	0	0	0	0	
0200	37	0	0	0	0	0	0	2	9	11	10	3	1	1	0	0	0	0	0	0	0	0	0	0	0	0	0	0	
0300	28	0	0	0	0	0	0	3	2	7	7	4	2	2	1	0	0	0	0	0	0	0	0	0	0	0	0	0	
0400	28	0	0	0	0	0	0	2	8	5	6	4	2	1	0	0	0	0	0	0	0	0	0	0	0	0	0	0	
0500	105	0	0	0	0	1	3	20	38	22	14	5	1	1	0	0	0	0	0	0	0	0	0	0	0	0	0	0	
0600	219	0	0	0	1	0	1	16	83	80	30	8	0	0	0	0	0	0	0	0	0	0	0	0	0	0	0	0	
0700	598	0	0	1	2	3	10	104	279	139	51	5	3	1	0	0	0	0	0	0	0	0	0	0	0	0	0	0	
0800	878	0	3	10	20	35	43	186	368	183	29	1	0	0	0	0	0	0	0	0	0	0	0	0	0	0	0	0	
0900	791	0	12	24	63	57	65	175	288	84	20	3	0	0	0	0	0	0	0	0	0	0	0	0	0	0	0	0	
1000	709	0	0	0	0	1	14	119	383	159	29	4	0	0	0	0	0	0	0	0	0	0	0	0	0	0	0	0	
1100	695	0	0	3	2	18	39	129	315	147	40	2	0	0	0	0	0	0	0	0	0	0	0	0	0	0	0	0	
1200	722	0	0	1	1	2	28	126	348	185	26	5	0	0	0	0	0	0	0	0	0	0	0	0	0	0	0	0	
1300	766	0	0	0	0	2	21	150	410	143	34	4	1	1	0	0	0	0	0	0	0	0	0	0	0	0	0	0	
1400	828	0	0	0	0	5	18	116	460	192	34	3	0	0	0	0	0	0	0	0	0	0	0	0	0	0	0	0	
1500	911	0	28	64	26	26	66	170	334	159	31	1	3	2	0	0	0	0	0	0	0	0	0	1	0	0	0	0	
1600	1005	0	9	26	30	36	48	143	465	211	34	3	0	0	0	0	0	0	0	0	0	0	0	0	0	0	0	0	
1700	978	0	0	1	18	25	48	113	441	280	51	1	0	0	0	0	0	0	0	0	0	0	0	0	0	0	0	0	
1800	935	0	16	39	24	7	48	176	394	187	37	6	1	0	0	0	0	0	0	0	0	0	0	0	0	0	0	0	
1900	499	0	0	0	0	0	6	103	265	96	23	6	0	0	0	0	0	0	0	0	0	0	0	0	0	0	0	0	
2000	362	0	0	0	0	0	7	49	148	109	37	11	1	0	0	0	0	0	0	0	0	0	0	0	0	0	0	0	
2100	208	0	0	0	0	0	1	18	87	66	29	2	3	1	0	0	0	0	1	0	0	0	0	0	0	0	0	0	
2200	178	0	0	0	0	0	1	9	58	61	31	9	5	3	0	0	0	1	0	0	0	0	0	0	0	0	0	0	
2300	98	0	0	0	0	0	0	1	28	36	17	8	6	2	0	0	0	0	0	0	0	0	0	0	0	0	0	0	
07-19	9816	0	68	169	186	217	448	1707	4485	2069	416	38	8	4	0	0	0	0	0	0	0	0	0	0	1	0	0	0	0
06-22	11104	0	68	169	187	217	463	1893	5068	2420	535	65	12	5	0	0	0	0	1	0	0	0	0	1	0	0	0	0	0
06-00	11380	0	68	169	187	217	464	1903	5154	2517	583	82	23	10	0	0	0	1	1	0	0	0	0	1	0	0	0	0	0
00-00	11654	0	68	169	187	218	469	1935	5227	2580	638	112	31	16	1	0	0	1	1	0	0	0	0	1	0	0	0	0	0



Site 2
 Location Oxford Road, Att - L/C, OSGR: SP 46884 37469
 Direction Northbound

8643 / Bodicote Business Park, Banbury
 September 2018
 Automatic Traffic Count

29 September 2018

Time	Total	Speed Bins (mph)																											
		0 - 5	5 - 10	10 - 15	15 - 20	20 - 25	25 - 30	30 - 35	35 - 40	40 - 45	45 - 50	50 - 55	55 - 60	60 - 65	65 - 70	70 - 75	75 - 80	80 - 85	85 - 90	90 - 95	95 - 100	100 - 105	105 - 110	110 - 115	115 - 120	120 - 125	125 - 130	130 - 135	135 - 140
0000	66	0	0	0	0	0	0	3	16	24	10	8	4	0	0	0	0	1	0	0	0	0	0	0	0	0	0	0	0
0100	38	0	0	0	0	0	1	1	7	7	9	10	2	1	0	0	0	0	0	0	0	0	0	0	0	0	0	0	0
0200	39	0	0	0	0	0	0	2	8	12	5	5	3	3	1	0	0	0	0	0	0	0	0	0	0	0	0	0	0
0300	33	0	0	0	0	0	0	1	7	10	8	1	6	0	0	0	0	0	0	0	0	0	0	0	0	0	0	0	0
0400	24	0	0	0	0	0	0	0	6	4	5	3	3	2	0	0	0	1	0	0	0	0	0	0	0	0	0	0	0
0500	55	0	0	0	0	0	0	3	14	17	11	3	3	2	1	1	0	0	0	0	0	0	0	0	0	0	0	0	0
0600	82	0	0	0	0	0	0	5	26	26	17	6	1	0	1	0	0	0	0	0	0	0	0	0	0	0	0	0	0
0700	235	0	0	0	0	0	1	14	93	76	28	12	3	6	1	1	0	0	0	0	0	0	0	0	0	0	0	0	0
0800	501	0	0	0	1	3	16	40	232	172	26	9	2	0	0	0	0	0	0	0	0	0	0	0	0	0	0	0	0
0900	689	0	0	0	2	3	25	131	347	145	29	7	0	0	0	0	0	0	0	0	0	0	0	0	0	0	0	0	0
1000	743	0	0	2	22	25	18	116	357	172	25	5	0	1	0	0	0	0	0	0	0	0	0	0	0	0	0	0	0
1100	681	0	2	0	0	10	8	99	365	146	43	6	1	1	0	0	0	0	0	0	0	0	0	0	0	0	0	0	0
1200	749	0	15	41	28	30	28	96	257	185	56	13	0	0	0	0	0	0	0	0	0	0	0	0	0	0	0	0	0
1300	666	0	0	0	3	14	22	103	283	175	57	8	0	1	0	0	0	0	0	0	0	0	0	0	0	0	0	0	0
1400	698	0	0	0	1	0	8	118	364	165	40	1	1	0	0	0	0	0	0	0	0	0	0	0	0	0	0	0	0
1500	644	0	0	0	1	9	7	64	320	185	49	5	2	2	0	0	0	0	0	0	0	0	0	0	0	0	0	0	0
1600	576	0	0	0	1	5	4	71	244	182	53	12	4	0	0	0	0	0	0	0	0	0	0	0	0	0	0	0	0
1700	577	0	0	0	0	0	0	41	258	199	58	18	2	1	0	0	0	0	0	0	0	0	0	0	0	0	0	0	0
1800	466	0	0	0	1	2	3	31	204	163	52	7	3	0	0	0	0	0	0	0	0	0	0	0	0	0	0	0	0
1900	378	0	0	0	0	0	3	34	179	120	30	7	5	0	0	0	0	0	0	0	0	0	0	0	0	0	0	0	0
2000	239	0	0	0	1	0	2	36	94	65	32	8	0	1	0	0	0	0	0	0	0	0	0	0	0	0	0	0	0
2100	207	0	0	0	0	0	2	29	87	47	29	11	1	0	0	1	0	0	0	0	0	0	0	0	0	0	0	0	0
2200	174	0	0	0	0	0	0	6	66	60	28	11	1	2	0	0	0	0	0	0	0	0	0	0	0	0	0	0	0
2300	122	0	0	0	0	0	0	7	43	38	16	11	7	0	0	0	0	0	0	0	0	0	0	0	0	0	0	0	0
07-19	7225	0	17	43	60	101	140	924	3324	1965	516	103	18	12	1	1	0	0	0	0	0	0	0	0	0	0	0	0	0
06-22	8131	0	17	43	61	101	147	1028	3710	2223	624	135	25	13	2	2	0	0	0	0	0	0	0	0	0	0	0	0	0
06-00	8427	0	17	43	61	101	147	1041	3819	2321	668	157	33	15	2	2	0	0	0	0	0	0	0	0	0	0	0	0	0
00-00	8682	0	17	43	61	101	148	1051	3877	2395	716	187	54	23	4	3	0	2	0	0	0	0	0	0	0	0	0	0	0

Site 2
 Location Oxford Road, Att - L/C, OSGR: SP 46884 37469
 Direction Northbound

8643 / Bodicote Business Park, Banbury
 September 2018
 Automatic Traffic Count

30 September 2018

Time	Total	Speed Bins (mph)																											
		0 - 5	5 - 10	10 - 15	15 - 20	20 - 25	25 - 30	30 - 35	35 - 40	40 - 45	45 - 50	50 - 55	55 - 60	60 - 65	65 - 70	70 - 75	75 - 80	80 - 85	85 - 90	90 - 95	95 - 100	100 - 105	105 - 110	110 - 115	115 - 120	120 - 125	125 - 130	130 - 135	135 - 140
0000	78	0	0	0	0	0	0	7	13	17	20	12	6	3	0	0	0	0	0	0	0	0	0	0	0	0	0	0	0
0100	68	0	0	0	0	2	1	4	14	18	12	12	3	0	1	1	0	0	0	0	0	0	0	0	0	0	0	0	0
0200	50	0	0	0	0	0	1	0	13	12	11	7	3	2	1	0	0	0	0	0	0	0	0	0	0	0	0	0	0
0300	28	0	0	0	0	0	0	1	5	4	7	4	1	5	0	1	0	0	0	0	0	0	0	0	0	0	0	0	0
0400	38	0	0	0	1	0	0	0	5	8	10	6	3	4	0	1	0	0	0	0	0	0	0	0	0	0	0	0	0
0500	25	0	0	0	0	0	0	1	7	8	3	2	1	1	1	1	0	0	0	0	0	0	0	0	0	0	0	0	0
0600	56	0	0	0	0	0	0	6	16	17	8	7	1	1	0	0	0	0	0	0	0	0	0	0	0	0	0	0	0
0700	137	0	0	0	1	0	0	9	39	47	25	7	6	3	0	0	0	0	0	0	0	0	0	0	0	0	0	0	0
0800	245	0	0	1	0	2	2	14	89	83	40	10	1	2	0	1	0	0	0	0	0	0	0	0	0	0	0	0	0
0900	456	0	0	0	0	5	13	73	203	124	32	4	2	0	0	0	0	0	0	0	0	0	0	0	0	0	0	0	0
1000	663	0	0	0	3	4	13	123	311	187	15	5	1	0	1	0	0	0	0	0	0	0	0	0	0	0	0	0	0
1100	602	0	0	2	3	4	18	117	269	160	25	4	0	0	0	0	0	0	0	0	0	0	0	0	0	0	0	0	0
1200	602	0	0	0	14	26	32	111	237	147	28	7	0	0	0	0	0	0	0	0	0	0	0	0	0	0	0	0	0
1300	607	0	0	2	0	3	20	88	289	170	27	4	4	0	0	0	0	0	0	0	0	0	0	0	0	0	0	0	0
1400	630	0	0	0	4	2	20	79	294	178	44	6	0	2	0	0	1	0	0	0	0	0	0	0	0	0	0	0	0
1500	572	0	0	1	1	0	3	103	265	152	38	8	1	0	0	0	0	0	0	0	0	0	0	0	0	0	0	0	0
1600	508	0	0	1	3	1	1	64	213	169	41	11	4	0	0	0	0	0	0	0	0	0	0	0	0	0	0	0	0
1700	493	0	0	0	0	0	4	75	196	160	43	11	4	0	0	0	0	0	0	0	0	0	0	0	0	0	0	0	0
1800	399	0	0	0	0	0	2	35	160	137	54	9	1	0	1	0	0	0	0	0	0	0	0	0	0	0	0	0	0
1900	327	0	0	0	0	0	0	32	164	83	34	11	1	1	0	0	1	0	0	0	0	0	0	0	0	0	0	0	0
2000	206	0	0	0	0	0	0	12	100	56	24	8	5	0	0	1	0	0	0	0	0	0	0	0	0	0	0	0	0
2100	158	0	0	0	0	0	0	26	57	46	19	7	0	3	0	0	0	0	0	0	0	0	0	0	0	0	0	0	0
2200	93	0	0	0	0	0	5	15	32	13	17	5	5	1	0	0	0	0	0	0	0	0	0	0	0	0	0	0	0
2300	51	0	0	0	0	0	0	7	17	11	7	4	2	2	1	0	0	0	0	0	0	0	0	0	0	0	0	0	0
07-19	5914	0	0	7	29	47	128	891	2565	1714	412	86	24	7	2	1	1	0	0	0	0	0	0	0	0	0	0	0	0
06-22	6661	0	0	7	29	47	128	967	2902	1916	497	119	31	12	2	2	2	0	0	0	0	0	0	0	0	0	0	0	0
06-00	6805	0	0	7	29	47	133	989	2951	1940	521	128	38	15	3	2	2	0	0	0	0	0	0	0	0	0	0	0	0
00-00	7092	0	0	7	30	49	135	1002	3008	2007	584	171	55	30	6	6	2	0	0	0	0	0	0	0	0	0	0	0	0



Site 2
 Location Oxford Road, Att - L/C, OSGR: SP 46884 37469
 Direction Northbound

8643 / Bodicote Business Park, Banbury
 September 2018
 Automatic Traffic Count

01 October 2018

Time	Total	Speed Bins (mph)																										
		0 - 5	5 - 10	10 - 15	15 - 20	20 - 25	25 - 30	30 - 35	35 - 40	40 - 45	45 - 50	50 - 55	55 - 60	60 - 65	65 - 70	70 - 75	75 - 80	80 - 85	85 - 90	90 - 95	95 - 100	100 - 105	105 - 110	110 - 115	115 - 120	120 - 125	125 - 130	130 - 135
0000	22	0	0	0	0	0	0	4	3	5	6	2	2	0	0	0	0	0	0	0	0	0	0	0	0	0	0	0
0100	21	0	0	0	0	0	0	0	4	6	3	4	1	2	1	0	0	0	0	0	0	0	0	0	0	0	0	0
0200	30	0	0	0	0	0	0	5	6	6	8	3	0	1	0	1	0	0	0	0	0	0	0	0	0	0	0	0
0300	21	0	0	0	0	0	1	0	5	4	1	4	5	1	0	0	0	0	0	0	0	0	0	0	0	0	0	0
0400	27	0	0	0	0	0	0	2	4	5	7	4	2	1	2	0	0	0	0	0	0	0	0	0	0	0	0	0
0500	82	0	0	0	0	0	0	4	29	26	11	8	1	2	1	0	0	0	0	0	0	0	0	0	0	0	0	0
0600	209	0	0	0	1	0	0	16	99	57	34	2	0	0	0	0	0	0	0	0	0	0	0	0	0	0	0	0
0700	562	0	0	0	4	26	41	91	235	132	27	2	3	0	1	0	0	0	0	0	0	0	0	0	0	0	0	0
0800	743	0	0	0	0	18	26	111	399	153	36	0	0	0	0	0	0	0	0	0	0	0	0	0	0	0	0	0
0900	712	0	0	0	2	1	34	209	323	124	17	1	1	0	0	0	0	0	0	0	0	0	0	0	0	0	0	0
1000	620	0	0	0	1	4	7	125	320	149	10	3	1	0	0	0	0	0	0	0	0	0	0	0	0	0	0	0
1100	582	0	0	0	1	4	17	95	286	149	26	4	0	0	0	0	0	0	0	0	0	0	0	0	0	0	0	0
1200	574	0	0	0	0	2	16	78	273	160	33	11	1	0	0	0	0	0	0	0	0	0	0	0	0	0	0	0
1300	670	0	0	0	0	1	18	120	323	170	35	1	0	1	1	0	0	0	0	0	0	0	0	0	0	0	0	0
1400	658	0	0	0	6	1	13	123	343	128	38	6	0	0	0	0	0	0	0	0	0	0	0	0	0	0	0	0
1500	738	0	0	1	1	2	22	135	327	205	39	5	1	0	0	0	0	0	0	0	0	0	0	0	0	0	0	0
1600	919	0	0	0	1	1	5	140	468	269	30	4	1	0	0	0	0	0	0	0	0	0	0	0	0	0	0	0
1700	1075	0	4	19	55	67	70	257	424	147	27	4	1	0	0	0	0	0	0	0	0	0	0	0	0	0	0	0
1800	856	0	0	0	5	14	59	205	385	156	26	5	0	0	1	0	0	0	0	0	0	0	0	0	0	0	0	0
1900	515	0	0	0	0	0	6	74	266	139	28	2	0	0	0	0	0	0	0	0	0	0	0	0	0	0	0	0
2000	234	0	0	0	1	0	0	21	105	70	28	5	3	1	0	0	0	0	0	0	0	0	0	0	0	0	0	0
2100	209	0	0	0	0	5	7	19	101	47	18	8	4	0	0	0	0	0	0	0	0	0	0	0	0	0	0	0
2200	143	0	0	0	0	0	1	12	62	45	12	8	1	1	1	0	0	0	0	0	0	0	0	0	0	0	0	0
2300	60	0	0	0	0	0	0	3	22	16	9	8	2	0	0	0	0	0	0	0	0	0	0	0	0	0	0	0
07-19	8709	0	4	20	76	141	328	1689	4106	1942	344	46	9	1	3	0	0	0	0	0	0	0	0	0	0	0	0	0
06-22	9876	0	4	20	78	146	341	1819	4677	2255	452	63	16	2	3	0	0	0	0	0	0	0	0	0	0	0	0	0
06-00	10079	0	4	20	78	146	342	1834	4761	2316	473	79	19	3	4	0	0	0	0	0	0	0	0	0	0	0	0	0
00-00	10282	0	4	20	78	146	343	1849	4812	2368	509	104	30	10	8	1	0	0	0	0	0	0	0	0	0	0	0	0

Site 2
 Location Oxford Road, Att - L/C, OSGR: SP 46884 37469
 Direction Northbound

8643 / Bodicote Business Park, Banbury
 September 2018
 Automatic Traffic Count

02 October 2018

Time	Total	Speed Bins (mph)																										
		0 - 5	5 - 10	10 - 15	15 - 20	20 - 25	25 - 30	30 - 35	35 - 40	40 - 45	45 - 50	50 - 55	55 - 60	60 - 65	65 - 70	70 - 75	75 - 80	80 - 85	85 - 90	90 - 95	95 - 100	100 - 105	105 - 110	110 - 115	115 - 120	120 - 125	125 - 130	130 - 135
0000	35	0	0	0	0	0	0	2	12	8	6	4	2	1	0	0	0	0	0	0	0	0	0	0	0	0	0	0
0100	21	0	0	0	0	0	1	1	4	6	3	2	2	1	1	0	0	0	0	0	0	0	0	0	0	0	0	0
0200	30	0	0	0	0	0	0	2	9	7	3	4	4	1	0	0	0	0	0	0	0	0	0	0	0	0	0	0
0300	28	0	0	0	0	0	0	3	4	3	8	7	1	1	1	0	0	0	0	0	0	0	0	0	0	0	0	0
0400	21	0	0	0	0	0	0	1	5	6	3	1	4	1	0	0	0	0	0	0	0	0	0	0	0	0	0	0
0500	91	0	0	0	0	0	0	0	25	36	12	13	3	2	0	0	0	0	0	0	0	0	0	0	0	0	0	0
0600	247	0	0	0	4	10	2	6	110	77	28	8	2	0	0	0	0	0	0	0	0	0	0	0	0	0	0	0
0700	620	0	0	0	1	4	17	101	291	171	29	4	2	0	0	0	0	0	0	0	0	0	0	0	0	0	0	0
0800	835	0	2	8	10	34	99	140	374	139	24	4	0	1	0	0	0	0	0	0	0	0	0	0	0	0	0	0
0900	700	0	0	2	1	27	33	114	317	172	29	3	2	0	0	0	0	0	0	0	0	0	0	0	0	0	0	0
1000	629	0	0	0	0	3	11	118	326	146	23	2	0	0	0	0	0	0	0	0	0	0	0	0	0	0	0	0
1100	611	0	0	0	3	10	33	115	312	112	19	5	2	0	0	0	0	0	0	0	0	0	0	0	0	0	0	0
1200	606	0	0	0	0	0	17	124	273	159	26	7	0	0	0	0	0	0	0	0	0	0	0	0	0	0	0	0
1300	649	0	0	0	0	7	9	112	353	143	21	3	1	0	0	0	0	0	0	0	0	0	0	0	0	0	0	0
1400	679	0	0	2	0	0	16	89	338	194	37	2	1	0	0	0	0	0	0	0	0	0	0	0	0	0	0	0
1500	772	0	0	0	2	4	46	146	368	158	41	6	1	0	0	0	0	0	0	0	0	0	0	0	0	0	0	0
1600	890	0	1	1	10	22	50	161	409	201	29	5	1	0	0	0	0	0	0	0	0	0	0	0	0	0	0	0
1700	1122	0	10	40	42	38	87	297	374	191	42	1	0	0	0	0	0	0	0	0	0	0	0	0	0	0	0	0
1800	909	0	0	0	2	17	34	165	491	173	21	6	0	0	0	0	0	0	0	0	0	0	0	0	0	0	0	0
1900	527	0	0	0	2	3	13	121	250	108	27	2	1	0	0	0	0	0	0	0	0	0	0	0	0	0	0	0
2000	299	0	0	0	0	0	3	30	108	108	40	7	2	0	0	1	0	0	0	0	0	0	0	0	0	0	0	0
2100	199	0	0	1	0	0	0	24	76	66	21	8	1	1	0	1	0	0	0	0	0	0	0	0	0	0	0	0
2200	121	0	0	0	0	0	0	7	42	40	21	7	4	0	0	0	0	0	0	0	0	0	0	0	0	0	0	0
2300	69	0	0	0	0	1	0	9	29	15	6	7	2	0	0	0	0	0	0	0	0	0	0	0	0	0	0	0
07-19	9022	0	13	53	71	166	452	1682	4226	1959	341	48	10	1	0	0	0	0	0	0	0	0	0	0	0	0	0	0
06-22	10294	0	13	54	77	179	470	1863	4770	2318	457	73	16	2	0	2	0	0	0	0	0	0	0	0	0	0	0	0
06-00	10484	0	13	54	77	180	470	1879	4841	2373	484	87	22	2	0	2	0	0	0	0	0	0	0	0	0	0	0	0
00-00	10710	0	13	54	77	180	471	1888	4900	2439	519	118	38	9	2	2	0	0	0	0	0	0	0	0	0	0	0	0



Site 2
 Location Oxford Road, Att - L/C, OSGR: SP 46884 37469
 Direction Northbound

8643 / Bodicote Business Park, Banbury
 September 2018
 Automatic Traffic Count

Virtual Day (7)

Time	Total	Speed Bins (mph)																										
		0 - 5	5 - 10	10 - 15	15 - 20	20 - 25	25 - 30	30 - 35	35 - 40	40 - 45	45 - 50	50 - 55	55 - 60	60 - 65	65 - 70	70 - 75	75 - 80	80 - 85	85 - 90	90 - 95	95 - 100	100 - 105	105 - 110	110 - 115	115 - 120	120 - 125	125 - 130	130 - 135
0000	44	0	0	0	0	0	0	3	9	12	10	6	3	1	0	0	0	0	0	0	0	0	0	0	0	0	0	0
0100	32	0	0	0	0	0	0	2	6	9	5	6	2	1	1	0	0	0	0	0	0	0	0	0	0	0	0	0
0200	35	0	0	0	0	0	0	2	7	9	7	5	2	1	0	0	0	0	0	0	0	0	0	0	0	0	0	0
0300	27	0	0	0	0	0	0	1	5	5	6	4	3	2	0	0	0	0	0	0	0	0	0	0	0	0	0	0
0400	27	0	0	0	0	0	0	1	5	6	6	4	2	2	0	0	0	0	0	0	0	0	0	0	0	0	0	0
0500	79	0	0	0	0	0	0	6	25	24	11	7	2	2	1	0	0	0	0	0	0	0	0	0	0	0	0	0
0600	188	0	0	0	2	2	1	13	77	59	26	7	2	1	0	0	0	0	0	0	0	0	0	0	0	0	0	0
0700	485	0	0	0	3	11	21	70	215	123	31	6	3	1	0	0	0	0	0	0	0	0	0	0	0	0	0	0
0800	695	0	1	3	5	15	37	115	327	157	31	6	0	0	0	0	0	0	0	0	0	0	0	0	0	0	0	0
0900	693	0	2	6	15	18	31	146	318	129	25	4	1	0	0	0	0	0	0	0	0	0	0	0	0	0	0	0
1000	662	0	0	0	4	5	13	117	333	162	24	4	0	0	0	0	0	0	0	0	0	0	0	0	0	0	0	0
1100	621	0	0	1	1	8	20	101	307	146	31	5	1	0	0	0	0	0	0	0	0	0	0	0	0	0	0	0
1200	643	0	2	6	6	10	22	104	283	168	34	7	0	0	0	0	0	0	0	0	0	0	0	0	0	0	0	0
1300	667	0	0	0	0	5	15	109	334	162	35	4	1	0	0	0	0	0	0	0	0	0	0	0	0	0	0	0
1400	703	0	0	0	2	2	18	105	358	174	39	4	1	0	0	0	0	0	0	0	0	0	0	0	0	0	0	0
1500	731	0	4	9	5	10	24	119	330	183	39	5	1	1	0	0	0	0	0	0	0	0	0	0	0	0	0	0
1600	830	0	3	8	11	16	29	137	376	206	37	6	2	0	0	0	0	0	0	0	0	0	0	0	0	0	0	0
1700	901	0	4	14	25	32	49	182	360	187	39	7	1	0	0	0	0	0	0	0	0	0	0	0	0	0	0	0
1800	775	0	13	42	27	15	33	129	322	154	33	5	1	0	0	0	0	0	0	0	0	0	0	0	0	0	0	0
1900	479	0	0	0	0	1	5	89	244	107	26	5	1	0	0	0	0	0	0	0	0	0	0	0	0	0	0	0
2000	287	0	0	0	0	0	2	38	122	83	30	7	2	0	0	0	0	0	0	0	0	0	0	0	0	0	0	0
2100	206	0	0	0	0	1	2	26	87	57	22	7	2	1	0	0	0	0	0	0	0	0	0	0	0	0	0	0
2200	150	0	0	0	0	0	1	12	57	45	21	8	4	1	1	0	0	0	0	0	0	0	0	0	0	0	0	0
2300	80	0	0	0	0	0	0	5	27	23	13	7	4	1	0	0	0	0	0	0	0	0	0	0	0	0	0	0
07-19	8406	0	29	89	104	147	311	1435	3861	1952	397	62	12	4	1	1	0	0	0	0	0	0	0	0	0	0	0	0
06-22	9565	0	29	89	106	150	322	1602	4391	2258	501	88	19	6	1	1	0	0	0	0	0	0	0	0	0	0	0	0
06-00	9795	0	29	89	106	150	323	1619	4475	2325	536	103	27	8	2	2	0	0	0	0	0	0	0	0	0	0	0	0
00-00	10039	0	29	89	107	150	324	1634	4533	2390	580	135	42	16	4	3	0	0	0	0	0	0	0	0	0	0	0	0



Site 2
 Location Oxford Road, Att - L/C, OSGR: SP 46884 37469
 Direction Northbound

8643 / Bodicote Business Park, Banbury
 September 2018
 Automatic Traffic Count

Virtual Week (1)

Time	Total	Speed Bins (mph)																													
		0 - 5	5 - 10	10 - 15	15 - 20	20 - 25	25 - 30	30 - 35	35 - 40	40 - 45	45 - 50	50 - 55	55 - 60	60 - 65	65 - 70	70 - 75	75 - 80	80 - 85	85 - 90	90 - 95	95 - 100	100 - 105	105 - 110	110 - 115	115 - 120	120 - 125	125 - 130	130 - 135	135 - 140		
Mon	10282	0	4	20	78	146	343	1849	4812	2368	509	104	30	10	8	1	0	0	0	0	0	0	0	0	0	0	0	0	0	0	0
Tue	10710	0	13	54	77	180	471	1888	4900	2439	519	118	38	9	2	2	0	0	0	0	0	0	0	0	0	0	0	0	0	0	
Wed	10953	0	76	263	194	187	353	1965	4971	2283	475	121	43	12	3	5	0	0	0	0	0	0	0	0	0	0	2	0	0		
Thu	10900	0	25	70	119	172	351	1749	4936	2659	621	134	43	12	7	2	0	0	0	0	0	0	0	0	0	0	0	0	0		
Fri	11654	0	68	169	187	218	469	1935	5227	2580	638	112	31	16	1	0	0	1	1	0	0	0	0	1	0	0	0	0	0		
Sat	8682	0	17	43	61	101	148	1051	3877	2395	716	187	54	23	4	3	0	2	0	0	0	0	0	0	0	0	0	0	0		
Sun	7092	0	0	7	30	49	135	1002	3008	2007	584	171	55	30	6	6	2	0	0	0	0	0	0	0	0	0	0	0	0		
5 Day Ave.	10900	0	37	115	131	181	397	1877	4969	2466	552	118	37	12	4	2	0	0	0	0	0	0	0	0	0	0	0	0	0		
7 Day Ave.	10039	0	29	89	107	150	324	1634	4533	2390	580	135	42	16	4	3	0	0	0	0	0	0	0	0	0	0	0	0	0		
--	70273	0	203	626	746	1053	2270	11439	31731	16731	4062	947	294	112	31	19	2	3	1	0	0	0	0	1	0	0	2	0	0		

Summary Graphs

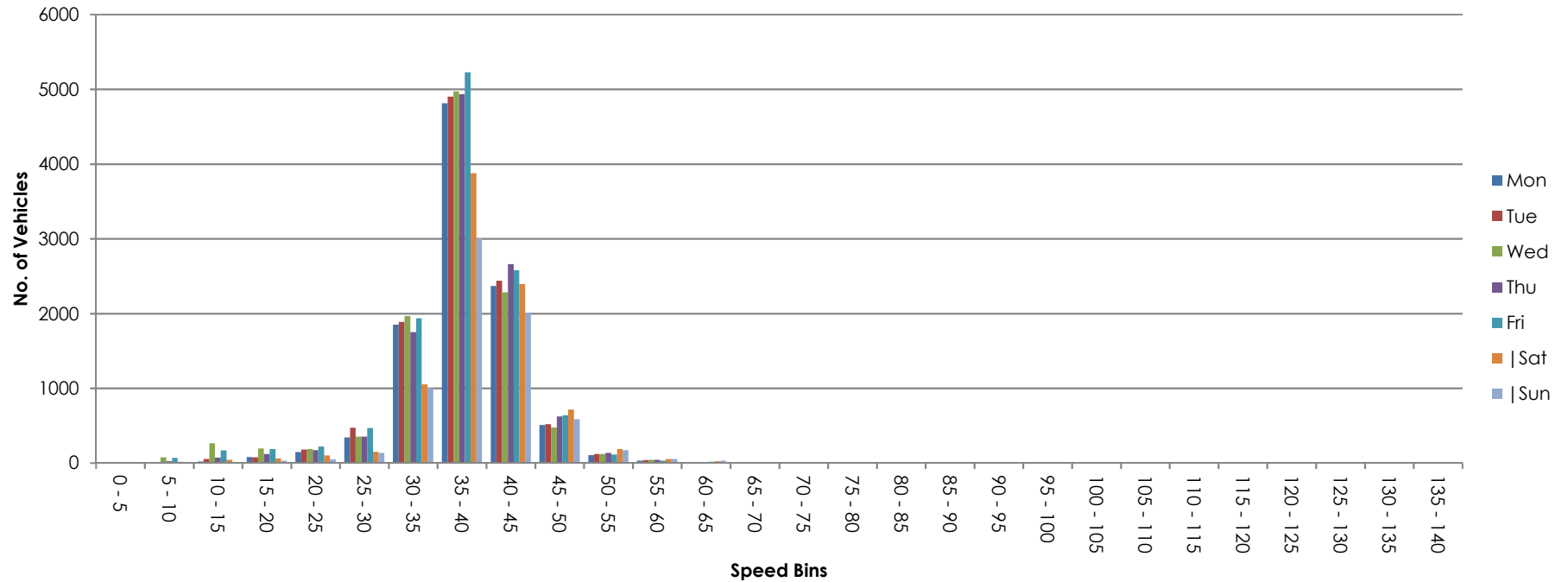

Site 2
 Location Oxford Road, Att - L/C, OSGR: SP 46884 37469
 Direction Southbound

8643 / Bodicote Business Park, Banbury
 September 2018
 Automatic Traffic Count

26 September 2018

Time	Total	Classification												>PSL 40	>PSL% 40	>SL1 46 ACPO	>SL1% 46 ACPO	>SL2 55 DfT	>SL2% 55 DfT	Mean	Vpp 85
		1 MCL	2 SV	3 SVT	4 TB2	5 TB3	6 T4	7 ART3	8 ART4	9 ART5	10 ART6	11 BD	12 DRT								
0000	28	1	22	0	2	0	0	0	1	2	0	0	0	21	75	10	35.7	4	14.3	45.4	52.8
0100	20	2	13	0	3	0	0	0	1	1	0	0	0	18	90	10	50	5	25	48.5	56.8
0200	27	0	19	0	5	0	0	0	0	3	0	0	0	23	85.2	11	40.7	4	14.8	46.6	51.9
0300	30	0	28	0	0	0	1	0	0	1	0	0	0	29	96.7	18	60	9	30	50.2	57.5
0400	38	0	33	0	4	0	0	0	1	0	0	0	0	27	71.1	19	50	7	18.4	46.7	55.9
0500	164	3	145	0	12	1	1	0	1	1	0	0	0	143	87.2	78	47.6	22	13.4	46.9	53.2
0600	588	6	528	1	47	1	0	0	2	1	1	0	1	325	55.3	104	17.7	17	2.9	41.5	46.5
0700	1052	13	937	5	88	2	2	0	1	0	4	0	0	335	31.8	74	7	2	0.2	37.8	42.7
0800	848	8	771	4	59	2	1	1	1	0	1	0	0	345	40.7	66	7.8	3	0.4	39.4	43.6
0900	646	3	582	1	52	1	1	0	3	2	0	0	1	312	48.3	64	9.9	5	0.8	40.1	44.3
1000	546	3	477	0	62	0	1	0	0	1	2	0	0	258	47.3	53	9.7	7	1.3	39.9	44.3
1100	648	8	577	2	51	7	1	0	0	1	1	0	0	213	32.9	47	7.3	5	0.8	38.9	43.2
1200	634	7	579	2	38	0	3	0	1	1	2	0	1	263	41.5	48	7.6	7	1.1	39.5	43.2
1300	658	4	590	3	51	3	4	1	1	1	0	0	0	259	39.4	50	7.6	5	0.8	39	43.4
1400	730	4	662	8	49	4	3	0	0	0	0	0	0	324	44.4	65	8.9	6	0.8	39.8	43.8
1500	763	1	713	1	40	3	1	0	1	1	2	0	0	314	41.2	50	6.6	4	0.5	39.3	43.4
1600	822	7	761	5	41	4	2	0	2	0	0	0	0	322	39.2	69	8.4	5	0.6	39	44.1
1700	832	5	795	5	22	1	0	0	1	1	1	0	1	394	47.4	74	8.9	9	1.1	40.1	44.5
1800	546	11	525	0	10	0	0	0	0	0	0	0	0	242	44.3	43	7.9	6	1.1	39.4	43.8
1900	524	3	504	0	17	0	0	0	0	0	0	0	0	190	36.3	48	9.2	4	0.8	39	44.1
2000	415	4	392	0	16	0	1	0	0	1	1	0	0	185	44.6	39	9.4	4	1	39.8	44.5
2100	239	4	226	2	6	0	0	0	0	1	0	0	0	132	55.2	53	22.2	7	2.9	41.4	47.6
2200	99	2	93	0	4	0	0	0	0	0	0	0	0	72	72.7	32	32.3	5	5.1	44	49.4
2300	70	1	64	1	3	0	0	0	0	1	0	0	0	51	72.9	27	38.6	6	8.6	44.2	50.1
07-19	8725	74	7969	36	563	27	19	2	11	8	13	0	3	3581	41	703	8.1	64	0.7	39.3	43.8
06-22	10491	91	9619	39	649	28	20	2	13	11	15	0	4	4413	42.1	947	9	96	0.9	39.5	44.1
06-00	10660	94	9776	40	656	28	20	2	13	12	15	0	4	4536	42.6	1006	9.4	107	1	39.5	44.3
00-00	10967	100	10036	40	682	29	22	2	17	20	15	0	4	4797	43.7	1152	10.5	158	1.4	39.8	44.5

Site 2
 Location Oxford Road, Att - L/C, OSGR: SP 46884 37469
 Direction Southbound

8643 / Bodicote Business Park, Banbury
 September 2018
 Automatic Traffic Count

27 September 2018

Time	Total	Classification												>PSL 40	>PSL% 40	>SL1 46 ACPO	>SL1% 46 ACPO	>SL2 55 DfT	>SL2% 55 DfT	Mean	Vpp 85
		1 MCL	2 SV	3 SVT	4 TB2	5 TB3	6 T4	7 ART3	8 ART4	9 ART5	10 ART6	11 BD	12 DRT								
0000	32	1	22	0	5	0	0	0	1	3	0	0	0	27	84.4	17	53.1	7	21.9	47.3	57
0100	18	1	12	0	4	0	0	0	0	1	0	0	0	16	88.9	11	61.1	5	27.8	49.1	55.3
0200	30	0	29	0	0	0	0	0	0	1	0	0	0	26	86.7	12	40	3	10	46.3	54.4
0300	31	0	21	0	7	0	0	0	0	3	0	0	0	24	77.4	18	58.1	7	22.6	47	55.3
0400	41	0	35	0	5	0	0	0	1	0	0	0	0	35	85.4	24	58.5	6	14.6	47.7	54.1
0500	171	3	144	0	17	3	1	1	1	0	1	0	0	129	75.4	61	35.7	11	6.4	44.4	51
0600	589	3	517	4	55	1	4	0	3	1	1	0	0	325	55.2	98	16.6	13	2.2	41.6	46.5
0700	1046	10	954	3	70	5	3	0	1	0	0	0	0	330	31.5	73	7	9	0.9	38.1	42.7
0800	917	7	836	1	54	9	4	0	1	1	4	0	0	247	26.9	52	5.7	3	0.3	34.6	42.5
0900	643	2	588	1	44	4	2	0	1	1	0	0	0	261	40.6	62	9.6	8	1.2	39.3	43.8
1000	586	3	516	2	60	2	1	0	1	0	1	0	0	261	44.5	47	8	4	0.7	39.7	44.1
1100	662	5	594	2	55	3	2	0	1	0	0	0	0	290	43.8	55	8.3	4	0.6	39.3	44.1
1200	683	6	621	2	44	2	2	0	2	1	2	1	0	291	42.6	61	8.9	7	1	39.6	44.1
1300	665	7	601	0	52	1	2	0	1	0	0	0	1	294	44.2	54	8.1	5	0.8	39.8	44.1
1400	668	3	604	3	47	1	5	0	1	1	3	0	0	258	38.6	58	8.7	10	1.5	39.2	44.1
1500	790	9	718	1	55	1	4	0	2	0	0	0	0	337	42.7	64	8.1	10	1.3	39.5	43.4
1600	792	9	738	2	35	4	0	0	0	1	3	0	0	385	48.6	73	9.2	12	1.5	40	44.5
1700	858	6	819	1	26	4	1	0	0	1	0	0	0	362	42.2	76	8.9	6	0.7	39.9	44.1
1800	600	8	574	2	14	1	0	0	0	1	0	0	0	318	53	89	14.8	10	1.7	40.5	45.9
1900	508	5	485	0	17	0	0	0	0	0	1	0	0	229	45.1	55	10.8	7	1.4	39.9	44.3
2000	349	6	330	0	10	0	1	0	0	0	2	0	0	152	43.6	32	9.2	2	0.6	39.9	44.3
2100	231	2	220	0	8	0	0	0	0	1	0	0	0	138	59.7	45	19.5	2	0.9	41.3	46.5
2200	127	3	119	1	4	0	0	0	0	0	0	0	0	74	58.3	28	22	5	3.9	42.3	48.8
2300	65	1	58	0	5	0	0	0	0	1	0	0	0	42	64.6	19	29.2	2	3.1	42.9	49.2
07-19	8910	75	8163	20	556	37	26	0	11	7	13	1	1	3634	40.8	764	8.6	88	1	39	43.8
06-22	10587	91	9715	24	646	38	31	0	14	9	17	1	1	4478	42.3	994	9.4	112	1.1	39.2	44.1
06-00	10779	95	9892	25	655	38	31	0	14	10	17	1	1	4594	42.6	1041	9.7	119	1.1	39.3	44.3
00-00	11102	100	10155	25	693	41	32	1	17	18	18	1	1	4851	43.7	1184	10.7	158	1.4	39.5	44.5

Site 2
 Location Oxford Road, Att - L/C, OSGR: SP 46884 37469
 Direction Southbound

8643 / Bodicote Business Park, Banbury
 September 2018
 Automatic Traffic Count

28 September 2018

Time	Total	Classification												>PSL 40	>PSL% 40	>SL1 46 ACPO	>SL1% 46 ACPO	>SL2 55 DfT	>SL2% 55 DfT	Mean	Vpp 85
		1 MCL	2 SV	3 SVT	4 TB2	5 TB3	6 T4	7 ART3	8 ART4	9 ART5	10 ART6	11 BD	12 DRT								
0000	39	0	30	0	5	0	0	0	2	2	0	0	0	28	71.8	20	51.3	1	2.6	44.4	49.2
0100	30	3	22	0	3	0	0	0	1	1	0	0	0	26	86.7	16	53.3	9	30	48.9	58.2
0200	29	1	17	0	7	0	1	0	1	2	0	0	0	24	82.8	8	27.6	1	3.4	44.3	51.4
0300	27	1	23	0	2	0	0	0	0	0	1	0	0	24	88.9	17	63	5	18.5	48.8	56.8
0400	33	0	28	0	5	0	0	0	0	0	0	0	0	26	78.8	19	57.6	9	27.3	48.3	56.1
0500	188	3	162	0	20	1	0	0	1	1	0	0	0	133	70.7	64	34	14	7.4	44.2	51.7
0600	556	7	494	1	46	1	3	0	2	1	1	0	0	308	55.4	101	18.2	11	2	41.6	46.8
0700	919	11	828	3	71	1	0	0	2	1	2	0	0	326	35.5	68	7.4	10	1.1	39	42.7
0800	833	6	755	0	69	2	0	0	0	1	0	0	0	325	39	55	6.6	8	1	39	42.9
0900	576	1	519	0	48	1	2	0	2	1	2	0	0	252	43.8	54	9.4	5	0.9	39.8	44.3
1000	638	4	573	3	55	0	2	0	0	0	1	0	0	249	39	47	7.4	4	0.6	39	43.8
1100	663	4	601	1	48	7	2	0	0	0	0	0	0	205	30.9	41	6.2	2	0.3	38.4	42.7
1200	752	4	685	3	54	4	0	0	0	2	0	0	0	249	33.1	48	6.4	7	0.9	38.2	42.7
1300	696	4	636	2	44	0	1	1	4	2	2	0	0	281	40.4	52	7.5	7	1	39.1	43.6
1400	736	2	686	1	42	1	1	0	2	1	0	0	0	307	41.7	69	9.4	6	0.8	39.5	43.8
1500	786	6	718	3	51	3	3	1	1	0	0	0	0	247	31.4	47	6	4	0.5	38	42.9
1600	931	6	874	1	46	1	0	0	1	1	1	0	0	351	37.7	51	5.5	7	0.8	38.7	42.9
1700	868	8	825	3	30	1	0	1	0	0	0	0	0	367	42.3	74	8.5	11	1.3	38.9	44.3
1800	612	7	584	2	19	0	0	0	0	0	0	0	0	288	47.1	69	11.3	7	1.1	40.2	45
1900	522	0	506	1	12	0	1	0	0	2	0	0	0	226	43.3	63	12.1	9	1.7	40.1	44.7
2000	317	0	308	1	7	0	0	0	0	1	0	0	0	183	57.7	54	17	9	2.8	41.7	46.3
2100	216	4	202	1	8	0	0	0	0	0	1	0	0	119	55.1	44	20.4	10	4.6	42.4	47.4
2200	132	2	119	0	10	0	0	0	0	1	0	0	0	94	71.2	46	34.8	8	6.1	44.6	50.1
2300	105	1	100	0	3	0	0	0	0	1	0	0	0	77	73.3	33	31.4	5	4.8	44.1	49.4
07-19	9010	63	8284	22	577	21	11	3	12	9	8	0	0	3447	38.3	675	7.5	78	0.9	39	43.4
06-22	10621	74	9794	26	650	22	15	3	14	13	10	0	0	4283	40.3	937	8.8	117	1.1	39.3	43.8
06-00	10858	77	10013	26	663	22	15	3	14	15	10	0	0	4454	41	1016	9.4	130	1.2	39.4	44.1
00-00	11204	85	10295	26	705	23	16	3	19	21	11	0	0	4715	42.1	1160	10.4	169	1.5	39.6	44.3



Site 2
 Location Oxford Road, Att - L/C, OSGR: SP 46884 37469
 Direction Southbound

8643 / Bodicote Business Park, Banbury
 September 2018
 Automatic Traffic Count

29 September 2018

Time	Total	Classification												>PSL 40	>PSL% 40	>SL1 46 ACPO	>SL1% 46 ACPO	>SL2 55 DfT	>SL2% 55 DfT	Mean	Vpp 85
		1 MCL	2 SV	3 SVT	4 TB2	5 TB3	6 T4	7 ART3	8 ART4	9 ART5	10 ART6	11 BD	12 DRT								
0000	59	0	51	1	5	0	0	0	2	0	0	0	0	44	74.6	21	35.6	3	5.1	45	53.5
0100	46	1	38	0	5	0	0	1	1	0	0	0	0	37	80.4	27	58.7	9	19.6	48.5	55.5
0200	33	0	29	0	2	0	0	0	1	1	0	0	0	23	69.7	16	48.5	5	15.2	45.8	53.5
0300	23	1	17	0	5	0	0	0	0	0	0	0	0	20	87	15	65.2	3	13	48.1	54.6
0400	34	0	28	1	4	0	0	0	1	0	0	0	0	28	82.4	18	52.9	7	20.6	47.1	55.9
0500	79	1	70	0	7	0	1	0	0	0	0	0	0	69	87.3	43	54.4	19	24.1	48.2	55.5
0600	151	2	126	1	21	0	0	0	1	0	0	0	0	114	75.5	49	32.5	14	9.3	44.6	50.6
0700	262	5	227	0	29	1	0	0	0	0	0	0	0	186	71	80	30.5	14	5.3	43.7	49.7
0800	374	3	330	1	35	1	2	0	0	1	0	1	0	263	70.3	71	19	9	2.4	42.5	46.8
0900	516	6	473	3	33	0	0	0	0	0	1	0	0	279	54.1	50	9.7	7	1.4	40.7	45
1000	606	5	578	2	19	2	0	0	0	0	0	0	0	281	46.4	80	13.2	7	1.2	40	45
1100	718	5	690	1	18	3	0	0	0	1	0	0	0	290	40.4	57	7.9	8	1.1	38.9	43.4
1200	778	12	736	3	24	1	1	0	0	0	1	0	0	285	36.6	74	9.5	4	0.5	38.9	44.1
1300	808	8	771	2	22	1	2	0	2	0	0	0	0	271	33.5	65	8	7	0.9	38.9	43.2
1400	656	13	622	1	20	0	0	0	0	0	0	0	0	270	41.2	66	10.1	8	1.2	39.5	43.8
1500	672	8	638	2	21	0	2	0	0	0	0	0	1	251	37.4	52	7.7	4	0.6	38.7	43.4
1600	717	14	677	4	20	1	0	0	0	1	0	0	0	339	47.3	60	8.4	10	1.4	39.9	44.3
1700	690	5	663	3	16	2	0	0	0	0	1	0	0	297	43	71	10.3	7	1	39.9	43.8
1800	515	3	494	1	16	0	1	0	0	0	0	0	0	272	52.8	64	12.4	7	1.4	40.4	45.2
1900	364	5	345	0	14	0	0	0	0	0	0	0	0	185	50.8	52	14.3	4	1.1	40.9	45.4
2000	229	0	222	1	6	0	0	0	0	0	0	0	0	117	51.1	32	14	6	2.6	40.7	45.4
2100	192	2	188	0	2	0	0	0	0	0	0	0	0	118	61.5	37	19.3	8	4.2	42.5	47
2200	142	0	138	0	4	0	0	0	0	0	0	0	0	93	65.5	33	23.2	3	2.1	42.7	47.2
2300	119	1	112	0	6	0	0	0	0	0	0	0	0	84	70.6	41	34.5	6	5	43.8	49
07-19	7312	87	6899	23	273	12	8	0	2	3	3	1	1	3284	44.9	790	10.8	92	1.3	39.8	44.5
06-22	8248	96	7780	25	316	12	8	0	3	3	3	1	1	3818	46.3	960	11.6	124	1.5	40	44.7
06-00	8509	97	8030	25	326	12	8	0	3	3	3	1	1	3995	47	1034	12.2	133	1.6	40.1	45
00-00	8783	100	8263	27	354	12	9	1	8	4	3	1	1	4216	48	1174	13.4	179	2	40.4	45.4



Site 2
 Location Oxford Road, Att - L/C, OSGR: SP 46884 37469
 Direction Southbound

8643 / Bodicote Business Park, Banbury
 September 2018
 Automatic Traffic Count

30 September 2018

Time	Total	Classification												>PSL 40	>PSL% 40	>SL1 46 ACPO	>SL1% 46 ACPO	>SL2 55 DfT	>SL2% 55 DfT	Mean	Vpp 85
		1 MCL	2 SV	3 SVT	4 TB2	5 TB3	6 T4	7 ART3	8 ART4	9 ART5	10 ART6	11 BD	12 DRT								
0000	65	0	56	1	8	0	0	0	0	0	0	0	0	37	56.9	28	43.1	3	4.6	43.5	50.8
0100	50	1	41	0	8	0	0	0	0	0	0	0	0	37	74	24	48	10	20	46.9	55.5
0200	38	0	37	0	1	0	0	0	0	0	0	0	0	33	86.8	22	57.9	7	18.4	48.2	56.6
0300	32	1	26	0	5	0	0	0	0	0	0	0	0	29	90.6	22	68.8	7	21.9	49.2	55.7
0400	25	1	21	0	3	0	0	0	0	0	0	0	0	19	76	14	56	5	20	50	56.6
0500	48	2	37	1	7	0	0	0	1	0	0	0	0	38	79.2	20	41.7	6	12.5	45.6	52.1
0600	102	0	93	0	9	0	0	0	0	0	0	0	0	83	81.4	32	31.4	8	7.8	44.9	51.4
0700	156	4	143	1	7	1	0	0	0	0	0	0	0	124	79.5	57	36.5	11	7.1	45	51.9
0800	284	3	263	2	16	0	0	0	0	0	0	0	0	206	72.5	66	23.2	10	3.5	42.9	47.4
0900	358	14	332	0	11	0	1	0	0	0	0	0	0	229	64	72	20.1	7	2	42.2	46.8
1000	528	14	485	3	26	0	0	0	0	0	0	0	0	240	45.5	58	11	4	0.8	40	45
1100	640	14	598	3	23	1	1	0	0	0	0	0	0	243	38	51	8	5	0.8	39.1	43.6
1200	842	17	798	4	17	4	0	0	1	0	0	1	0	284	33.7	53	6.3	7	0.8	38.7	42.7
1300	721	14	688	1	13	0	1	0	2	0	2	0	0	258	35.8	62	8.6	7	1	39.1	43.6
1400	577	5	551	2	17	0	0	0	2	0	0	0	0	261	45.2	62	10.7	7	1.2	40	44.5
1500	610	6	575	3	23	1	0	0	1	0	0	0	1	254	41.6	55	9	8	1.3	39.4	43.6
1600	563	8	527	3	24	0	0	0	1	0	0	0	0	295	52.4	51	9.1	7	1.2	40.2	44.3
1700	399	2	380	1	12	0	1	1	0	0	2	0	0	262	65.7	83	20.8	10	2.5	42.4	47.6
1800	343	5	321	2	14	0	1	0	0	0	0	0	0	206	60.1	68	19.8	11	3.2	41.9	47.4
1900	250	2	238	1	9	0	0	0	0	0	0	0	0	168	67.2	53	21.2	8	3.2	42.6	47.4
2000	183	1	173	0	8	0	0	0	0	0	1	0	0	123	67.2	52	28.4	5	2.7	43.1	49.2
2100	128	1	121	0	6	0	0	0	0	0	0	0	0	82	64.1	37	28.9	6	4.7	43.5	49
2200	74	0	70	0	4	0	0	0	0	0	0	0	0	57	77	28	37.8	6	8.1	45.1	51.2
2300	48	0	44	0	4	0	0	0	0	0	0	0	0	30	62.5	16	33.3	2	4.2	43.8	50.8
07-19	6021	106	5661	25	203	7	5	1	7	0	4	1	1	2862	47.5	738	12.3	94	1.6	40.2	45
06-22	6684	110	6286	26	235	7	5	1	7	0	5	1	1	3318	49.6	912	13.6	121	1.8	40.5	45.4
06-00	6806	110	6400	26	243	7	5	1	7	0	5	1	1	3405	50	956	14	129	1.9	40.6	45.6
00-00	7064	115	6618	28	275	7	5	1	8	0	5	1	1	3598	50.9	1086	15.4	167	2.4	40.8	46.1



Site 2
 Location Oxford Road, Att - L/C, OSGR: SP 46884 37469
 Direction Southbound

8643 / Bodicote Business Park, Banbury
 September 2018
 Automatic Traffic Count

01 October 2018

Time	Total	Classification												>PSL 40	>PSL% 40	>SL1 46 ACPO	>SL1% 46 ACPO	>SL2 55 DfT	>SL2% 55 DfT	Mean	Vpp 85
		1 MCL	2 SV	3 SVT	4 TB2	5 TB3	6 T4	7 ART3	8 ART4	9 ART5	10 ART6	11 BD	12 DRT								
0000	16	1	13	0	2	0	0	0	0	0	0	0	0	11	68.8	7	43.8	3	18.8	45.5	56.4
0100	17	1	13	0	3	0	0	0	0	0	0	0	0	14	82.4	11	64.7	4	23.5	49.5	57.5
0200	18	1	16	0	1	0	0	0	0	0	0	0	0	13	72.2	9	50	4	22.2	49	57.5
0300	33	0	27	0	4	1	0	0	0	0	0	1	0	27	81.8	19	57.6	6	18.2	47	55
0400	48	0	42	0	6	0	0	0	0	0	0	0	0	37	77.1	24	50	12	25	47.3	57.7
0500	175	3	151	0	16	1	1	0	1	1	1	0	0	143	81.7	77	44	15	8.6	45.8	52.1
0600	568	3	514	0	44	0	2	1	1	2	1	0	0	311	54.8	88	15.5	11	1.9	41.1	46.1
0700	1094	13	1011	3	59	4	1	0	1	0	2	0	0	287	26.2	46	4.2	6	0.5	34.7	41.8
0800	955	4	889	2	44	8	3	1	0	2	1	0	1	239	25	39	4.1	3	0.3	30.5	41.6
0900	578	4	535	1	37	0	0	0	0	0	1	0	0	231	40	58	10	8	1.4	39.1	44.1
1000	596	3	527	1	58	3	0	1	1	2	0	0	0	257	43.1	47	7.9	4	0.7	39.5	43.8
1100	607	2	545	1	50	5	0	0	0	3	1	0	0	220	36.2	43	7.1	5	0.8	38.8	42.9
1200	612	6	551	3	43	4	1	0	1	1	2	0	0	284	46.4	56	9.2	6	1	39.6	44.1
1300	611	3	565	0	37	3	0	0	1	2	0	0	0	265	43.4	40	6.5	3	0.5	39.3	43.2
1400	662	4	599	3	50	2	1	0	0	1	2	0	0	243	36.7	51	7.7	7	1.1	39.2	43.2
1500	708	5	639	4	50	3	1	0	3	1	1	1	0	268	37.9	52	7.3	3	0.4	38.6	43.4
1600	789	5	736	2	40	3	3	0	0	0	0	0	0	311	39.4	66	8.4	4	0.5	39	43.6
1700	786	7	736	7	29	2	1	1	0	0	2	0	1	299	38	63	8	4	0.5	38.6	43.2
1800	567	2	536	4	24	1	0	0	0	0	0	0	0	283	49.9	54	9.5	1	0.2	40.2	44.5
1900	486	3	466	1	15	0	0	0	0	0	1	0	0	176	36.2	30	6.2	7	1.4	38.7	42.5
2000	277	2	262	0	10	0	0	0	0	2	1	0	0	164	59.2	54	19.5	9	3.2	42.1	47.2
2100	163	3	157	0	3	0	0	0	0	0	0	0	0	104	63.8	29	17.8	4	2.5	42.1	46.8
2200	109	2	103	0	3	0	0	0	0	1	0	0	0	78	71.6	27	24.8	7	6.4	44	49.7
2300	45	0	43	0	2	0	0	0	0	0	0	0	0	36	80	15	33.3	6	13.3	45.2	53.9
07-19	8565	58	7869	31	521	38	11	3	7	12	12	1	2	3187	37.2	615	7.2	54	0.6	37.6	43.4
06-22	10059	69	9268	32	593	38	13	4	8	16	15	1	2	3942	39.2	816	8.1	85	0.8	38.1	43.6
06-00	10213	71	9414	32	598	38	13	4	8	17	15	1	2	4056	39.7	858	8.4	98	1	38.2	43.6
00-00	10520	77	9676	32	630	40	14	4	9	18	16	2	2	4301	40.9	1005	9.6	142	1.3	38.4	44.1



Site 2
 Location Oxford Road, Att - L/C, OSGR: SP 46884 37469
 Direction Southbound

8643 / Bodicote Business Park, Banbury
 September 2018
 Automatic Traffic Count

02 October 2018

Time	Total	Classification												>PSL 40	>PSL% 40	>SL1 46 ACPO	>SL1% 46 ACPO	>SL2 55 DfT	>SL2% 55 DfT	Mean	Vpp 85
		1 MCL	2 SV	3 SVT	4 TB2	5 TB3	6 T4	7 ART3	8 ART4	9 ART5	10 ART6	11 BD	12 DRT								
0000	22	0	15	0	3	0	1	0	1	2	0	0	0	15	68.2	7	31.8	1	4.5	44.3	50.1
0100	18	3	9	0	4	0	0	0	0	2	0	0	0	15	83.3	11	61.1	1	5.6	46.6	50.3
0200	20	1	13	0	3	0	0	0	1	2	0	0	0	18	90	11	55	3	15	49.6	53.9
0300	28	0	25	0	3	0	0	0	0	0	0	0	0	25	89.3	22	78.6	9	32.1	51.7	60.4
0400	45	0	42	0	2	0	0	0	1	0	0	0	0	38	84.4	22	48.9	7	15.6	46.8	53.7
0500	166	1	144	0	15	3	0	0	1	0	2	0	0	141	84.9	67	40.4	11	6.6	45.5	51.4
0600	564	7	505	1	48	2	0	0	1	0	0	0	0	316	56	90	16	11	2	41.3	46.1
0700	1086	11	981	6	68	12	3	0	2	1	2	0	0	265	24.4	46	4.2	3	0.3	35.2	41.4
0800	947	2	869	9	50	10	5	0	1	0	1	0	0	242	25.6	50	5.3	4	0.4	34	41.8
0900	597	3	534	4	45	6	3	0	0	1	1	0	0	296	49.6	56	9.4	4	0.7	40.1	43.8
1000	594	3	520	1	61	4	2	0	0	1	2	0	0	239	40.2	49	8.2	6	1	39.1	42.9
1100	608	2	550	0	50	4	2	0	0	0	0	0	0	205	33.7	31	5.1	2	0.3	38.2	42.3
1200	643	4	593	2	37	4	0	0	0	1	2	0	0	235	36.5	49	7.6	3	0.5	38.8	43.4
1300	597	5	542	4	40	2	0	0	1	0	2	0	1	262	43.9	63	10.6	8	1.3	39.4	44.5
1400	657	4	604	1	46	1	0	0	0	0	0	0	1	260	39.6	69	10.5	7	1.1	39.6	44.1
1500	703	3	648	0	46	2	3	0	0	1	0	0	0	292	41.5	58	8.3	6	0.9	39.3	43.8
1600	808	4	749	2	44	4	2	0	0	1	2	0	0	376	46.5	59	7.3	5	0.6	39.8	44.1
1700	819	8	773	0	34	3	1	0	0	0	0	0	0	375	45.8	90	11	10	1.2	39.8	44.7
1800	597	6	565	1	25	0	0	0	0	0	0	0	0	269	45.1	62	10.4	5	0.8	39.6	44.3
1900	493	4	466	2	19	0	1	0	0	0	1	0	0	212	43	41	8.3	3	0.6	39.1	43.4
2000	312	0	300	1	10	0	0	0	0	1	0	0	0	193	61.9	50	16	6	1.9	41.6	46.3
2100	234	3	227	0	3	0	1	0	0	0	0	0	0	133	56.8	47	20.1	15	6.4	42.2	48.1
2200	109	2	104	0	2	0	0	0	0	1	0	0	0	86	78.9	41	37.6	10	9.2	45.1	52.6
2300	63	0	62	0	0	0	0	0	0	1	0	0	0	42	66.7	23	36.5	5	7.9	44.9	52.3
07-19	8656	55	7928	30	546	52	21	0	4	6	12	0	2	3316	38.3	682	7.9	63	0.7	38.3	43.4
06-22	10259	69	9426	34	626	54	23	0	5	7	13	0	2	4170	40.6	910	8.9	98	1	38.7	43.8
06-00	10431	71	9592	34	628	54	23	0	5	9	13	0	2	4298	41.2	974	9.3	113	1.1	38.8	43.8
00-00	10730	76	9840	34	658	57	24	0	9	15	15	0	2	4550	42.4	1114	10.4	145	1.4	39	44.3

Site 2
 Location Oxford Road, Att - L/C, OSGR: SP 46884 37469
 Direction Southbound

8643 / Bodicote Business Park, Banbury
 September 2018
 Automatic Traffic Count

Virtual Day (7)

Time	Total	Classification												>PSL 40	>PSL% 40	>SL1 46 ACPO	>SL1% 46 ACPO	>SL2 55 DfT	>SL2% 55 DfT	Mean	Vpp 85
		1 MCL	2 SV	3 SVT	4 TB2	5 TB3	6 T4	7 ART3	8 ART4	9 ART5	10 ART6	11 BD	12 DRT								
0000	37	0	30	0	4	0	0	0	1	1	0	0	0	26	70.1	16	42.1	3	8.4	44.8	52.6
0100	28	2	21	0	4	0	0	0	0	1	0	0	0	23	81.9	16	55.3	6	21.6	48.1	56.4
0200	28	0	23	0	3	0	0	0	0	1	0	0	0	23	82.1	13	45.6	4	13.8	46.9	54.4
0300	29	0	24	0	4	0	0	0	0	1	0	0	0	25	87.3	19	64.2	7	22.5	48.8	57
0400	38	0	33	0	4	0	0	0	1	0	0	0	0	30	79.5	20	53	8	20.1	47.6	56.1
0500	142	2	122	0	13	1	1	0	1	0	1	0	0	114	80.3	59	41.4	14	9.9	45.6	52.3
0600	445	4	397	1	39	1	1	0	1	1	1	0	0	255	57.2	80	18	12	2.7	41.7	46.8
0700	802	10	726	3	56	4	1	0	1	0	1	0	0	265	33	63	7.9	8	1	37.4	43.2
0800	737	5	673	3	47	5	2	0	0	1	1	0	0	267	36.2	57	7.7	6	0.8	36.3	43.4
0900	559	5	509	1	39	2	1	0	1	1	1	0	0	266	47.5	59	10.6	6	1.1	40	44.5
1000	585	5	525	2	49	2	1	0	0	1	1	0	0	255	43.6	54	9.3	5	0.9	39.6	44.1
1100	649	6	594	1	42	4	1	0	0	1	0	0	0	238	36.6	46	7.1	4	0.7	38.8	43.2
1200	706	8	652	3	37	3	1	0	1	1	1	0	0	270	38.2	56	7.9	6	0.8	39	43.4
1300	679	6	628	2	37	1	1	0	2	1	1	0	0	270	39.7	55	8.1	6	0.9	39.2	43.6
1400	669	5	618	3	39	1	1	0	1	0	1	0	0	275	41	63	9.4	7	1.1	39.6	43.8
1500	719	5	664	2	41	2	2	0	1	0	0	0	0	280	39	54	7.5	6	0.8	39	43.4
1600	775	8	723	3	36	2	1	0	1	1	1	0	0	340	43.9	61	7.9	7	0.9	39.4	43.8
1700	750	6	713	3	24	2	1	0	0	0	1	0	0	337	44.9	76	10.1	8	1.1	39.7	44.5
1800	540	6	514	2	17	0	0	0	0	0	0	0	0	268	49.7	64	11.9	7	1.2	40.2	45
1900	450	3	430	1	15	0	0	0	0	0	0	0	0	198	44	49	10.9	6	1.3	39.8	44.5
2000	297	2	284	0	10	0	0	0	0	1	1	0	0	160	53.7	45	15	6	2	41.1	45.9
2100	200	3	192	0	5	0	0	0	0	0	0	0	0	118	58.9	42	20.8	7	3.7	42.1	47.4
2200	113	2	107	0	4	0	0	0	0	0	0	0	0	79	69.9	34	29.7	6	5.6	43.9	49.4
2300	74	1	69	0	3	0	0	0	0	1	0	0	0	52	70.3	25	33.8	5	6.2	44	50.8
07-19	8171	74	7539	27	463	28	14	1	8	6	9	1	1	3330	40.8	710	8.7	76	0.9	39	43.8
06-22	9564	86	8841	29	531	28	16	1	9	8	11	1	2	4060	42.5	925	9.7	108	1.1	39.3	44.3
06-00	9751	88	9017	30	538	28	16	1	9	9	11	1	2	4191	43	984	10.1	118	1.2	39.3	44.3
00-00	10053	93	9269	30	571	30	17	2	12	14	12	1	2	4433	44.1	1125	11.2	160	1.6	39.6	44.7



Site 2
 Location Oxford Road, Att - L/C, OSGR: SP 46884 37469
 Direction Southbound

8643 / Bodicote Business Park, Banbury
 September 2018
 Automatic Traffic Count

Virtual Week (1)

Time	Total	Classification												>PSL 40	>PSL% 40	>SL1 46 ACPO	>SL1% 46 ACPO	>SL2 55 DfT	>SL2% 55 DfT	Mean	Vpp 85
		1 MCL	2 SV	3 SVT	4 TB2	5 TB3	6 T4	7 ART3	8 ART4	9 ART5	10 ART6	11 BD	12 DRT								
Mon	10520	77	9676	32	630	40	14	4	9	18	16	2	2	4301	40.9	1005	9.6	142	1.3	38.4	44.1
Tue	10730	76	9840	34	658	57	24	0	9	15	15	0	2	4550	42.4	1114	10.4	145	1.4	39	44.3
Wed	10967	100	10036	40	682	29	22	2	17	20	15	0	4	4797	43.7	1152	10.5	158	1.4	39.8	44.5
Thu	11102	100	10155	25	693	41	32	1	17	18	18	1	1	4851	43.7	1184	10.7	158	1.4	39.5	44.5
Fri	11204	85	10295	26	705	23	16	3	19	21	11	0	0	4715	42.1	1160	10.4	169	1.5	39.6	44.3
Sat	8783	100	8263	27	354	12	9	1	8	4	3	1	1	4216	48	1174	13.4	179	2	40.4	45.4
Sun	7064	115	6618	28	275	7	5	1	8	0	5	1	1	3598	50.9	1086	15.4	167	2.4	40.8	46.1
5 Day Ave.	10905	88	10000	31	674	38	22	2	14	18	15	1	2	4643	42.6	1123	10.3	154	1.4	39.3	44.3
7 Day Ave.	10053	93	9269	30	571	30	17	2	12	14	12	1	2	4433	44.1	1125	11.2	160	1.6	39.6	44.7
--	70370	653	64883	212	3997	209	122	12	87	96	83	5	11	31028	44.1	7875	11.2	1118	1.6	39.6	44.7

Summary Graphs

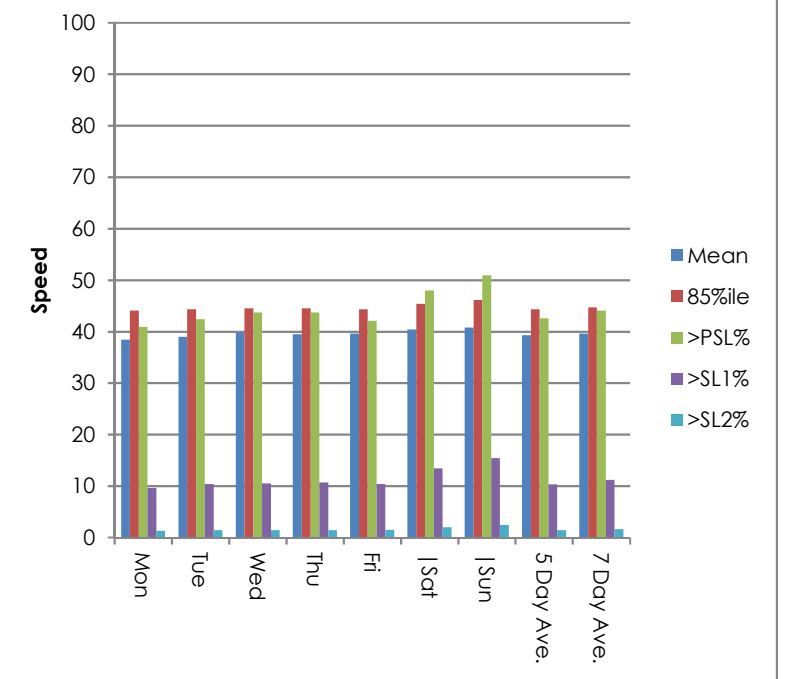
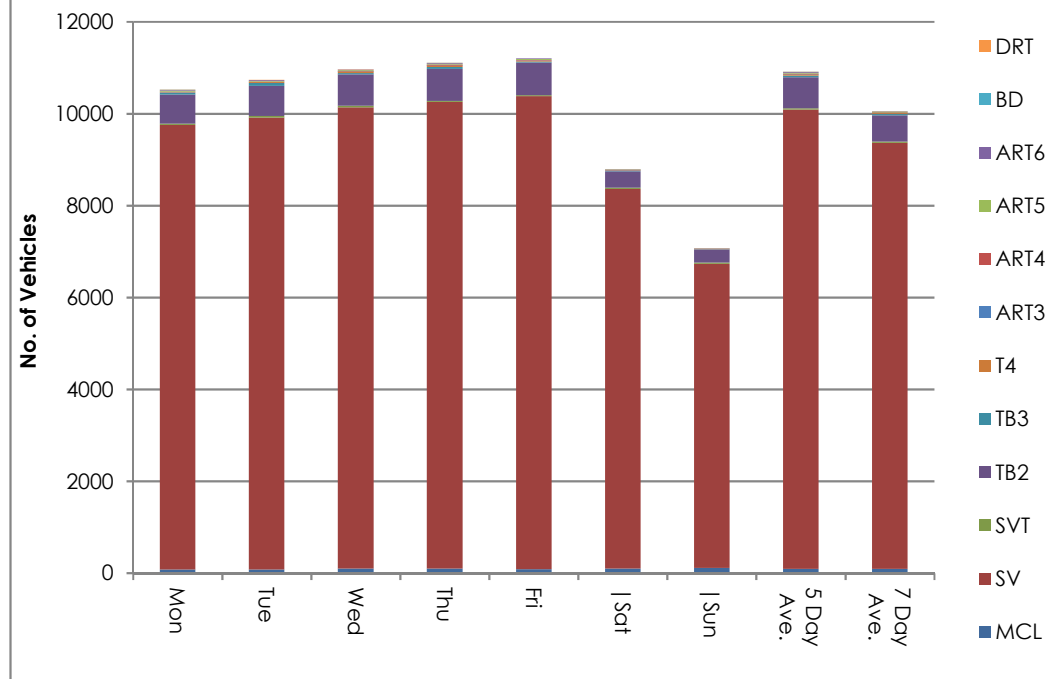

Site 2
 Location Oxford Road, Att - L/C, OSGR: SP 46884 37469
 Direction Southbound

**8643 / Bodicote Business Park, Banbury
 September 2018
 Automatic Traffic Count**

26 September 2018

Time	Total	Speed Bins (mph)																											
		0 - 5	5 - 10	10 - 15	15 - 20	20 - 25	25 - 30	30 - 35	35 - 40	40 - 45	45 - 50	50 - 55	55 - 60	60 - 65	65 - 70	70 - 75	75 - 80	80 - 85	85 - 90	90 - 95	95 - 100	100 - 105	105 - 110	110 - 115	115 - 120	120 - 125	125 - 130	130 - 135	135 - 140
0000	28	0	0	0	0	0	0	0	7	8	5	4	4	0	0	0	0	0	0	0	0	0	0	0	0	0	0	0	0
0100	20	0	0	0	0	0	0	0	2	6	5	2	2	3	0	0	0	0	0	0	0	0	0	0	0	0	0	0	0
0200	27	0	0	0	0	0	0	1	3	7	9	3	2	0	2	0	0	0	0	0	0	0	0	0	0	0	0	0	0
0300	30	0	0	0	0	0	0	0	1	8	8	4	5	3	1	0	0	0	0	0	0	0	0	0	0	0	0	0	0
0400	38	0	0	0	0	0	0	2	9	7	8	5	3	2	2	0	0	0	0	0	0	0	0	0	0	0	0	0	0
0500	164	0	0	0	1	0	1	2	17	56	41	24	8	11	1	2	0	0	0	0	0	0	0	0	0	0	0	0	0
0600	588	0	0	0	0	0	4	50	209	188	96	24	11	5	0	1	0	0	0	0	0	0	0	0	0	0	0	0	0
0700	1052	0	2	5	6	2	30	263	409	242	79	12	1	1	0	0	0	0	0	0	0	0	0	0	0	0	0	0	0
0800	848	0	0	0	0	0	7	116	380	254	72	16	3	0	0	0	0	0	0	0	0	0	0	0	0	0	0	0	0
0900	646	0	0	0	0	0	2	85	247	225	57	25	3	1	1	0	0	0	0	0	0	0	0	0	0	0	0	0	0
1000	546	0	0	3	0	4	5	54	222	191	46	14	4	2	0	1	0	0	0	0	0	0	0	0	0	0	0	0	0
1100	648	0	0	0	0	2	6	105	322	148	48	12	4	1	0	0	0	0	0	0	0	0	0	0	0	0	0	0	0
1200	634	0	0	0	0	0	3	83	285	198	48	10	5	2	0	0	0	0	0	0	0	0	0	0	0	0	0	0	0
1300	658	0	0	0	0	5	24	86	284	191	60	3	2	3	0	0	0	0	0	0	0	0	0	0	0	0	0	0	0
1400	730	0	0	0	0	0	4	86	316	240	61	17	6	0	0	0	0	0	0	0	0	0	0	0	0	0	0	0	0
1500	763	0	0	0	0	1	10	120	318	236	64	10	2	2	0	0	0	0	0	0	0	0	0	0	0	0	0	0	0
1600	822	0	0	2	4	2	23	111	358	225	71	21	3	2	0	0	0	0	0	0	0	0	0	0	0	0	0	0	0
1700	832	0	0	0	0	0	17	91	330	290	82	13	8	1	0	0	0	0	0	0	0	0	0	0	0	0	0	0	0
1800	546	2	1	0	2	3	11	77	208	179	43	14	5	0	0	0	0	0	0	1	0	0	0	0	0	0	0	0	0
1900	524	0	0	0	4	0	10	92	228	127	45	14	2	0	1	1	0	0	0	0	0	0	0	0	0	0	0	0	0
2000	415	0	0	2	0	2	0	50	176	132	40	9	4	0	0	0	0	0	0	0	0	0	0	0	0	0	0	0	0
2100	239	0	0	0	0	3	5	19	80	73	31	21	4	2	1	0	0	0	0	0	0	0	0	0	0	0	0	0	0
2200	99	0	0	0	0	0	1	3	23	34	26	7	2	1	1	1	0	0	0	0	0	0	0	0	0	0	0	0	0
2300	70	0	0	1	0	0	0	4	14	24	16	5	2	4	0	0	0	0	0	0	0	0	0	0	0	0	0	0	0
07-19	8725	2	3	10	12	19	142	1277	3679	2619	731	167	46	15	1	1	0	0	0	1	0	0	0	0	0	0	0	0	0
06-22	10491	2	3	12	16	24	161	1488	4372	3139	943	235	67	22	3	3	0	0	0	1	0	0	0	0	0	0	0	0	0
06-00	10660	2	3	13	16	24	162	1495	4409	3197	985	247	71	27	4	4	0	0	0	1	0	0	0	0	0	0	0	0	0
00-00	10967	2	3	13	17	24	163	1500	4448	3289	1061	289	95	46	10	6	0	0	0	1	0	0	0	0	0	0	0	0	0

Site 2
 Location Oxford Road, Att - L/C, OSGR: SP 46884 37469
 Direction Southbound

8643 / Bodicote Business Park, Banbury
 September 2018
 Automatic Traffic Count

27 September 2018

Time	Total	Speed Bins (mph)																											
		0 - 5	5 - 10	10 - 15	15 - 20	20 - 25	25 - 30	30 - 35	35 - 40	40 - 45	45 - 50	50 - 55	55 - 60	60 - 65	65 - 70	70 - 75	75 - 80	80 - 85	85 - 90	90 - 95	95 - 100	100 - 105	105 - 110	110 - 115	115 - 120	120 - 125	125 - 130	130 - 135	135 - 140
0000	32	0	0	0	0	0	0	0	5	8	10	2	5	2	0	0	0	0	0	0	0	0	0	0	0	0	0	0	0
0100	18	0	0	0	0	0	0	0	2	3	7	1	3	1	1	0	0	0	0	0	0	0	0	0	0	0	0	0	0
0200	30	0	0	0	0	0	0	0	4	9	11	3	3	0	0	0	0	0	0	0	0	0	0	0	0	0	0	0	0
0300	31	0	0	0	0	0	2	1	4	5	7	5	5	2	0	0	0	0	0	0	0	0	0	0	0	0	0	0	0
0400	41	0	0	0	0	0	0	1	5	10	12	7	3	2	0	0	1	0	0	0	0	0	0	0	0	0	0	0	0
0500	171	0	0	1	0	0	0	10	31	61	35	22	4	4	2	1	0	0	0	0	0	0	0	0	0	0	0	0	0
0600	589	0	0	0	0	0	1	40	223	196	91	25	8	3	1	0	1	0	0	0	0	0	0	0	0	0	0	0	0
0700	1046	0	4	6	1	4	32	199	470	235	69	17	8	1	0	0	0	0	0	0	0	0	0	0	0	0	0	0	0
0800	917	5	18	44	43	30	31	168	331	175	52	17	3	0	0	0	0	0	0	0	0	0	0	0	0	0	0	0	0
0900	643	0	0	0	0	0	17	104	261	186	50	17	6	1	1	0	0	0	0	0	0	0	0	0	0	0	0	0	0
1000	586	0	0	1	0	0	3	70	251	191	58	8	2	2	0	0	0	0	0	0	0	0	0	0	0	0	0	0	0
1100	662	0	0	1	3	5	29	82	252	213	59	14	3	1	0	0	0	0	0	0	0	0	0	0	0	0	0	0	0
1200	683	0	0	0	2	2	11	87	290	206	65	13	3	1	1	0	0	0	0	0	0	0	1	1	0	0	0	0	0
1300	665	0	0	0	0	0	12	77	282	210	67	12	5	0	0	0	0	0	0	0	0	0	0	0	0	0	0	0	0
1400	668	0	0	2	0	0	11	124	273	182	55	11	5	4	0	1	0	0	0	0	0	0	0	0	0	0	0	0	0
1500	790	0	0	0	1	0	4	105	343	253	61	13	6	4	0	0	0	0	0	0	0	0	0	0	0	0	0	0	0
1600	792	0	0	0	2	3	15	95	292	276	84	13	4	7	0	0	1	0	0	0	0	0	0	0	0	0	0	0	0
1700	858	0	0	0	0	0	5	94	397	262	76	18	3	1	1	0	1	0	0	0	0	0	0	0	0	0	0	0	0
1800	600	0	0	0	0	2	11	60	209	207	89	12	10	0	0	0	0	0	0	0	0	0	0	0	0	0	0	0	0
1900	508	0	0	0	0	0	6	76	197	164	44	14	3	2	2	0	0	0	0	0	0	0	0	0	0	0	0	0	0
2000	349	0	0	1	0	0	2	38	156	106	36	8	2	0	0	0	0	0	0	0	0	0	0	0	0	0	0	0	0
2100	231	0	0	0	0	0	4	16	73	84	35	17	1	1	0	0	0	0	0	0	0	0	0	0	0	0	0	0	0
2200	127	0	0	0	0	0	0	13	40	39	21	9	3	0	2	0	0	0	0	0	0	0	0	0	0	0	0	0	0
2300	65	0	0	1	0	0	0	4	18	21	14	5	1	0	1	0	0	0	0	0	0	0	0	0	0	0	0	0	0
07-19	8910	5	22	54	52	46	181	1265	3651	2596	785	165	58	22	3	1	2	0	0	0	0	1	1	0	0	0	0	0	0
06-22	10587	5	22	55	52	46	194	1435	4300	3146	991	229	72	28	6	1	3	0	0	0	0	1	1	0	0	0	0	0	0
06-00	10779	5	22	56	52	46	194	1452	4358	3206	1026	243	76	28	9	1	3	0	0	0	0	1	1	0	0	0	0	0	0
00-00	11102	5	22	57	52	46	196	1464	4409	3302	1108	283	99	39	12	2	4	0	0	0	0	1	1	0	0	0	0	0	0



Site 2
 Location Oxford Road, Att - L/C, OSGR: SP 46884 37469
 Direction Southbound

8643 / Bodicote Business Park, Banbury
 September 2018
 Automatic Traffic Count

28 September 2018

Time	Total	Speed Bins (mph)																											
		0 - 5	5 - 10	10 - 15	15 - 20	20 - 25	25 - 30	30 - 35	35 - 40	40 - 45	45 - 50	50 - 55	55 - 60	60 - 65	65 - 70	70 - 75	75 - 80	80 - 85	85 - 90	90 - 95	95 - 100	100 - 105	105 - 110	110 - 115	115 - 120	120 - 125	125 - 130	130 - 135	135 - 140
0000	39	0	0	0	1	0	0	2	8	7	18	2	0	1	0	0	0	0	0	0	0	0	0	0	0	0	0	0	0
0100	30	0	0	0	0	0	0	0	4	5	11	1	5	3	1	0	0	0	0	0	0	0	0	0	0	0	0	0	0
0200	29	0	0	0	0	0	0	0	5	15	4	4	0	1	0	0	0	0	0	0	0	0	0	0	0	0	0	0	0
0300	27	0	0	0	0	0	0	1	2	6	6	7	3	2	0	0	0	0	0	0	0	0	0	0	0	0	0	0	0
0400	33	0	0	0	0	0	0	0	7	5	6	6	7	2	0	0	0	0	0	0	0	0	0	0	0	0	0	0	0
0500	188	0	0	0	0	0	1	7	47	65	32	22	8	5	1	0	0	0	0	0	0	0	0	0	0	0	0	0	0
0600	556	0	0	0	0	0	0	46	202	179	87	31	6	3	2	0	0	0	0	0	0	0	0	0	0	0	0	0	0
0700	919	0	0	0	1	0	9	170	413	245	56	15	5	2	2	0	1	0	0	0	0	0	0	0	0	0	0	0	0
0800	833	0	1	0	0	1	7	155	344	259	45	13	5	0	0	1	1	1	0	0	0	0	0	0	0	0	0	0	0
0900	576	0	0	0	0	2	10	69	243	178	54	15	5	0	0	0	0	0	0	0	0	0	0	0	0	0	0	0	0
1000	638	0	0	0	5	2	14	113	255	185	50	10	3	0	1	0	0	0	0	0	0	0	0	0	0	0	0	0	0
1100	663	0	0	0	1	6	7	125	319	152	36	15	1	1	0	0	0	0	0	0	0	0	0	0	0	0	0	0	0
1200	752	0	1	8	3	6	13	147	325	185	45	12	4	3	0	0	0	0	0	0	0	0	0	0	0	0	0	0	0
1300	696	0	0	0	1	1	15	106	292	210	56	8	6	1	0	0	0	0	0	0	0	0	0	0	0	0	0	0	0
1400	736	0	0	0	1	0	10	115	303	224	51	26	3	0	3	0	0	0	0	0	0	0	0	0	0	0	0	0	0
1500	786	0	0	2	9	0	29	165	334	176	54	13	1	1	2	0	0	0	0	0	0	0	0	0	0	0	0	0	0
1600	931	0	0	0	0	0	26	172	382	275	60	9	7	0	0	0	0	0	0	0	0	0	0	0	0	0	0	0	0
1700	868	0	4	4	10	12	15	131	325	262	75	19	3	4	3	1	0	0	0	0	0	0	0	0	0	0	0	0	0
1800	612	1	0	1	0	2	2	71	247	192	69	20	6	0	0	1	0	0	0	0	0	0	0	0	0	0	0	0	0
1900	522	0	0	0	0	0	2	67	227	149	49	19	7	1	1	0	0	0	0	0	0	0	0	0	0	0	0	0	0
2000	317	0	0	0	0	0	0	24	110	114	47	13	5	2	0	1	0	1	0	0	0	0	0	0	0	0	0	0	0
2100	216	0	0	0	0	0	0	11	86	63	33	13	5	0	2	2	0	0	1	0	0	0	0	0	0	0	0	0	0
2200	132	0	0	0	0	0	1	4	33	42	29	15	4	0	2	0	2	0	0	0	0	0	0	0	0	0	0	0	0
2300	105	0	0	0	0	0	0	9	19	37	24	11	2	0	2	1	0	0	0	0	0	0	0	0	0	0	0	0	0
07-19	9010	1	6	15	31	32	157	1539	3782	2543	651	175	49	12	11	3	2	1	0	0	0	0	0	0	0	0	0	0	0
06-22	10621	1	6	15	31	32	159	1687	4407	3048	867	251	72	18	16	6	2	2	1	0	0	0	0	0	0	0	0	0	0
06-00	10858	1	6	15	31	32	160	1700	4459	3127	920	277	78	18	20	7	4	2	1	0	0	0	0	0	0	0	0	0	0
00-00	11204	1	6	15	32	32	161	1710	4532	3230	997	319	101	32	22	7	4	2	1	0	0	0	0	0	0	0	0	0	0

Site 2
 Location Oxford Road, Att - L/C, OSGR: SP 46884 37469
 Direction Southbound

8643 / Bodicote Business Park, Banbury
 September 2018
 Automatic Traffic Count

29 September 2018

Time	Total	Speed Bins (mph)																										
		0 - 5	5 - 10	10 - 15	15 - 20	20 - 25	25 - 30	30 - 35	35 - 40	40 - 45	45 - 50	50 - 55	55 - 60	60 - 65	65 - 70	70 - 75	75 - 80	80 - 85	85 - 90	90 - 95	95 - 100	100 - 105	105 - 110	110 - 115	115 - 120	120 - 125	125 - 130	130 - 135
0000	59	0	0	0	0	0	1	1	13	19	9	13	1	1	1	0	0	0	0	0	0	0	0	0	0	0	0	0
0100	46	0	0	0	0	0	0	1	8	9	11	8	4	1	2	1	1	0	0	0	0	0	0	0	0	0	0	0
0200	33	0	0	0	0	0	0	1	9	7	6	5	3	2	0	0	0	0	0	0	0	0	0	0	0	0	0	0
0300	23	0	0	0	0	0	0	0	3	4	7	6	2	1	0	0	0	0	0	0	0	0	0	0	0	0	0	0
0400	34	0	0	0	0	0	0	2	4	9	8	4	4	2	1	0	0	0	0	0	0	0	0	0	0	0	0	0
0500	79	0	0	0	0	0	1	0	9	20	16	14	15	2	2	0	0	0	0	0	0	0	0	0	0	0	0	0
0600	151	0	0	0	0	0	0	6	31	56	31	13	9	4	1	0	0	0	0	0	0	0	0	0	0	0	0	0
0700	262	0	0	0	1	0	1	15	59	88	62	22	5	4	3	1	0	0	1	0	0	0	0	0	0	0	0	0
0800	374	0	0	0	0	0	1	13	97	171	67	16	7	0	2	0	0	0	0	0	0	0	0	0	0	0	0	0
0900	516	0	0	1	1	2	0	34	199	197	63	12	4	1	0	1	0	0	1	0	0	0	0	0	0	0	0	0
1000	606	0	0	0	0	0	13	69	243	186	71	17	5	0	2	0	0	0	0	0	0	0	0	0	0	0	0	0
1100	718	0	0	1	4	0	9	135	279	221	50	11	7	1	0	0	0	0	0	0	0	0	0	0	0	0	0	0
1200	778	0	0	0	0	0	26	133	334	191	72	18	2	2	0	0	0	0	0	0	0	0	0	0	0	0	0	0
1300	808	0	0	0	0	0	12	146	379	195	53	16	5	2	0	0	0	0	0	0	0	0	0	0	0	0	0	0
1400	656	0	0	0	4	1	14	80	287	191	49	22	3	2	3	0	0	0	0	0	0	0	0	0	0	0	0	0
1500	672	0	0	5	7	4	5	106	294	177	51	19	4	0	0	0	0	0	0	0	0	0	0	0	0	0	0	0
1600	717	0	0	1	3	8	5	53	308	249	62	18	10	0	0	0	0	0	0	0	0	0	0	0	0	0	0	0
1700	690	0	0	0	2	3	1	75	312	217	63	10	6	0	1	0	0	0	0	0	0	0	0	0	0	0	0	0
1800	515	0	0	0	0	5	11	54	173	191	58	16	5	1	0	1	0	0	0	0	0	0	0	0	0	0	0	0
1900	364	0	0	0	0	0	3	26	150	119	51	11	4	0	0	0	0	0	0	0	0	0	0	0	0	0	0	0
2000	229	0	0	0	0	0	8	13	91	79	25	7	4	1	0	0	1	0	0	0	0	0	0	0	0	0	0	0
2100	192	0	0	0	0	0	1	11	62	70	32	8	5	2	0	0	0	1	0	0	0	0	0	0	0	0	0	0
2200	142	0	0	0	0	0	0	9	40	51	30	9	1	0	1	1	0	0	0	0	0	0	0	0	0	0	0	0
2300	119	0	0	0	0	0	1	6	28	38	30	10	4	0	1	1	0	0	0	0	0	0	0	0	0	0	0	0
07-19	7312	0	0	8	22	23	98	913	2964	2274	721	197	63	13	11	3	0	0	2	0	0	0	0	0	0	0	0	0
06-22	8248	0	0	8	22	23	110	969	3298	2598	860	236	85	20	12	3	1	1	2	0	0	0	0	0	0	0	0	0
06-00	8509	0	0	8	22	23	111	984	3366	2687	920	255	90	20	14	5	1	1	2	0	0	0	0	0	0	0	0	0
00-00	8783	0	0	8	22	23	113	989	3412	2755	977	305	119	29	20	6	2	1	2	0	0	0	0	0	0	0	0	0



Site 2
 Location Oxford Road, Att - L/C, OSGR: SP 46884 37469
 Direction Southbound

8643 / Bodicote Business Park, Banbury
 September 2018
 Automatic Traffic Count

30 September 2018

Time	Total	Speed Bins (mph)																										
		0 - 5	5 - 10	10 - 15	15 - 20	20 - 25	25 - 30	30 - 35	35 - 40	40 - 45	45 - 50	50 - 55	55 - 60	60 - 65	65 - 70	70 - 75	75 - 80	80 - 85	85 - 90	90 - 95	95 - 100	100 - 105	105 - 110	110 - 115	115 - 120	120 - 125	125 - 130	130 - 135
0000	65	0	0	0	0	0	0	5	23	8	15	11	2	1	0	0	0	0	0	0	0	0	0	0	0	0	0	0
0100	50	0	0	0	0	0	0	2	11	10	10	7	7	2	1	0	0	0	0	0	0	0	0	0	0	0	0	0
0200	38	0	0	0	0	0	0	1	4	10	8	8	3	4	0	0	0	0	0	0	0	0	0	0	0	0	0	0
0300	32	0	0	0	0	0	0	0	3	6	8	8	6	1	0	0	0	0	0	0	0	0	0	0	0	0	0	0
0400	25	0	0	0	0	0	0	0	6	4	4	6	1	1	1	0	2	0	0	0	0	0	0	0	0	0	0	0
0500	48	0	0	0	0	0	1	5	4	16	11	5	2	1	1	2	0	0	0	0	0	0	0	0	0	0	0	0
0600	102	0	0	0	0	0	0	3	16	43	21	11	5	2	1	0	0	0	0	0	0	0	0	0	0	0	0	0
0700	156	0	0	0	1	0	0	3	28	59	35	19	7	1	2	1	0	0	0	0	0	0	0	0	0	0	0	0
0800	284	0	0	0	0	3	0	9	66	121	63	12	8	1	0	0	1	0	0	0	0	0	0	0	0	0	0	0
0900	358	0	0	1	1	0	0	25	102	143	55	24	3	1	3	0	0	0	0	0	0	0	0	0	0	0	0	0
1000	528	0	0	1	0	2	3	65	217	160	62	14	2	1	1	0	0	0	0	0	0	0	0	0	0	0	0	0
1100	640	0	0	1	1	2	6	101	286	178	54	6	4	0	1	0	0	0	0	0	0	0	0	0	0	0	0	0
1200	842	0	0	0	2	1	21	151	383	219	50	8	3	1	2	0	0	0	1	0	0	0	0	0	0	0	0	0
1300	721	0	0	0	1	2	7	121	332	178	63	10	3	1	1	1	0	1	0	0	0	0	0	0	0	0	0	0
1400	577	0	0	0	1	1	10	72	232	183	53	18	4	2	0	0	0	1	0	0	0	0	0	0	0	0	0	0
1500	610	0	0	0	1	1	19	93	242	183	47	16	5	1	1	1	0	0	0	0	0	0	0	0	0	0	0	0
1600	563	0	0	0	0	0	9	74	185	224	52	12	6	0	1	0	0	0	0	0	0	0	0	0	0	0	0	0
1700	399	0	0	0	0	0	4	13	120	159	69	24	7	2	1	0	0	0	0	0	0	0	0	0	0	0	0	0
1800	343	0	0	0	0	0	3	25	109	124	52	19	8	2	1	0	0	0	0	0	0	0	0	0	0	0	0	0
1900	250	0	0	0	0	0	0	11	71	103	44	13	5	3	0	0	0	0	0	0	0	0	0	0	0	0	0	0
2000	183	0	0	0	0	0	2	12	46	60	39	19	2	3	0	0	0	0	0	0	0	0	0	0	0	0	0	0
2100	128	0	0	0	0	0	1	3	42	36	28	12	3	1	1	0	0	1	0	0	0	0	0	0	0	0	0	0
2200	74	0	0	0	0	0	0	0	17	23	21	7	2	1	3	0	0	0	0	0	0	0	0	0	0	0	0	0
2300	48	0	0	0	0	0	1	2	15	11	9	8	2	0	0	0	0	0	0	0	0	0	0	0	0	0	0	0
07-19	6021	0	0	3	8	12	82	752	2302	1931	655	182	60	13	14	3	1	2	1	0	0	0	0	0	0	0	0	0
06-22	6684	0	0	3	8	12	85	781	2477	2173	787	237	75	22	16	3	1	3	1	0	0	0	0	0	0	0	0	0
06-00	6806	0	0	3	8	12	86	783	2509	2207	817	252	79	23	19	3	1	3	1	0	0	0	0	0	0	0	0	0
00-00	7064	0	0	3	8	12	87	796	2560	2261	873	297	100	33	22	5	3	3	1	0	0	0	0	0	0	0	0	0



Site 2
 Location Oxford Road, Att - L/C, OSGR: SP 46884 37469
 Direction Southbound

8643 / Bodicote Business Park, Banbury
 September 2018
 Automatic Traffic Count

01 October 2018

Time	Total	Speed Bins (mph)																										
		0 - 5	5 - 10	10 - 15	15 - 20	20 - 25	25 - 30	30 - 35	35 - 40	40 - 45	45 - 50	50 - 55	55 - 60	60 - 65	65 - 70	70 - 75	75 - 80	80 - 85	85 - 90	90 - 95	95 - 100	100 - 105	105 - 110	110 - 115	115 - 120	120 - 125	125 - 130	130 - 135
0000	16	0	0	0	0	0	0	3	2	4	2	2	2	0	1	0	0	0	0	0	0	0	0	0	0	0	0	0
0100	17	0	0	0	0	0	0	2	1	3	4	3	2	1	0	0	0	1	0	0	0	0	0	0	0	0	0	0
0200	18	0	0	0	0	0	0	0	5	3	2	4	2	0	1	0	1	0	0	0	0	0	0	0	0	0	0	0
0300	33	0	0	0	0	0	0	3	3	7	10	4	3	3	0	0	0	0	0	0	0	0	0	0	0	0	0	0
0400	48	0	0	0	0	0	0	4	7	13	3	9	9	1	2	0	0	0	0	0	0	0	0	0	0	0	0	0
0500	175	0	0	0	0	0	3	2	27	57	51	20	7	3	3	1	0	1	0	0	0	0	0	0	0	0	0	0
0600	568	0	0	0	0	0	2	58	197	196	85	19	3	7	0	0	1	0	0	0	0	0	0	0	0	0	0	0
0700	1094	12	30	37	38	34	44	202	410	221	54	6	5	0	0	1	0	0	0	0	0	0	0	0	0	0	0	0
0800	955	1	78	118	67	57	27	82	286	188	41	7	3	0	0	0	0	0	0	0	0	0	0	0	0	0	0	0
0900	578	0	1	5	5	5	9	70	252	159	52	12	4	2	0	1	1	0	0	0	0	0	0	0	0	0	0	0
1000	596	0	0	0	1	0	19	72	247	190	50	13	2	1	1	0	0	0	0	0	0	0	0	0	0	0	0	0
1100	607	0	0	0	2	11	7	99	268	173	33	9	4	0	1	0	0	0	0	0	0	0	0	0	0	0	0	0
1200	612	0	0	0	0	4	13	93	218	215	48	15	4	0	1	1	0	0	0	0	0	0	0	0	0	0	0	0
1300	611	0	0	0	0	2	5	110	229	205	42	15	3	0	0	0	0	0	0	0	0	0	0	0	0	0	0	0
1400	662	0	0	1	0	1	12	80	325	177	44	15	3	1	3	0	0	0	0	0	0	0	0	0	0	0	0	0
1500	708	0	0	0	2	2	16	142	278	197	58	10	2	0	0	1	0	0	0	0	0	0	0	0	0	0	0	0
1600	789	0	0	0	0	1	25	138	314	221	72	14	1	2	0	1	0	0	0	0	0	0	0	0	0	0	0	0
1700	786	0	0	2	7	9	18	119	332	222	60	13	3	0	1	0	0	0	0	0	0	0	0	0	0	0	0	0
1800	567	0	0	0	0	0	1	51	232	207	61	14	1	0	0	0	0	0	0	0	0	0	0	0	0	0	0	0
1900	486	0	0	0	1	2	5	78	224	139	27	3	5	2	0	0	0	0	0	0	0	0	0	0	0	0	0	0
2000	277	0	0	0	0	0	0	15	98	96	49	10	6	2	0	1	0	0	0	0	0	0	0	0	0	0	0	0
2100	163	0	0	0	0	0	1	9	49	71	17	12	3	1	0	0	0	0	0	0	0	0	0	0	0	0	0	0
2200	109	0	0	0	0	0	0	3	28	43	21	7	4	1	0	0	1	1	0	0	0	0	0	0	0	0	0	0
2300	45	0	0	0	0	0	0	1	8	21	3	6	4	1	0	1	0	0	0	0	0	0	0	0	0	0	0	0
07-19	8565	13	109	163	122	126	196	1258	3391	2375	615	143	35	6	7	5	1	0	0	0	0	0	0	0	0	0	0	0
06-22	10059	13	109	163	123	128	204	1418	3959	2877	793	187	52	18	7	6	2	0	0	0	0	0	0	0	0	0	0	0
06-00	10213	13	109	163	123	128	204	1422	3995	2941	817	200	60	20	7	7	3	1	0	0	0	0	0	0	0	0	0	0
00-00	10520	13	109	163	123	128	207	1436	4040	3028	889	242	85	28	14	8	4	3	0	0	0	0	0	0	0	0	0	0



Site 2
 Location Oxford Road, Att - L/C, OSGR: SP 46884 37469
 Direction Southbound

8643 / Bodicote Business Park, Banbury
 September 2018
 Automatic Traffic Count

02 October 2018

Time	Total	Speed Bins (mph)																										
		0 - 5	5 - 10	10 - 15	15 - 20	20 - 25	25 - 30	30 - 35	35 - 40	40 - 45	45 - 50	50 - 55	55 - 60	60 - 65	65 - 70	70 - 75	75 - 80	80 - 85	85 - 90	90 - 95	95 - 100	100 - 105	105 - 110	110 - 115	115 - 120	120 - 125	125 - 130	130 - 135
0000	22	0	0	0	0	0	0	1	6	7	4	3	0	0	1	0	0	0	0	0	0	0	0	0	0	0	0	0
0100	18	0	0	0	0	0	0	0	3	4	7	3	0	0	1	0	0	0	0	0	0	0	0	0	0	0	0	0
0200	20	0	0	0	0	0	0	1	1	4	7	4	0	1	0	1	1	0	0	0	0	0	0	0	0	0	0	0
0300	28	0	0	0	0	0	0	0	3	2	9	5	4	3	2	0	0	0	0	0	0	0	0	0	0	0	0	0
0400	45	0	0	0	0	0	0	1	6	15	7	9	6	1	0	0	0	0	0	0	0	0	0	0	0	0	0	0
0500	166	0	0	0	0	0	0	4	21	56	55	19	8	2	1	0	0	0	0	0	0	0	0	0	0	0	0	0
0600	564	0	0	1	0	0	0	41	206	210	71	24	9	1	1	0	0	0	0	0	0	0	0	0	0	0	0	0
0700	1086	2	26	46	10	5	77	224	431	208	39	15	2	1	0	0	0	0	0	0	0	0	0	0	0	0	0	0
0800	947	4	37	29	56	30	61	144	344	180	44	14	3	1	0	0	0	0	0	0	0	0	0	0	0	0	0	0
0900	597	0	0	0	1	3	7	49	241	226	49	17	3	1	0	0	0	0	0	0	0	0	0	0	0	0	0	0
1000	594	0	0	0	0	4	6	102	243	177	46	10	6	0	0	0	0	0	0	0	0	0	0	0	0	0	0	0
1100	608	0	0	0	1	1	17	120	264	164	31	8	1	1	0	0	0	0	0	0	0	0	0	0	0	0	0	0
1200	643	0	0	0	0	0	16	114	278	163	56	13	3	0	0	0	0	0	0	0	0	0	0	0	0	0	0	0
1300	597	0	0	0	1	4	24	82	224	183	57	14	5	3	0	0	0	0	0	0	0	0	0	0	0	0	0	0
1400	657	0	0	0	0	0	8	104	285	178	55	20	4	2	1	0	0	0	0	0	0	0	0	0	0	0	0	0
1500	703	0	0	1	0	3	21	88	298	214	60	12	4	0	1	1	0	0	0	0	0	0	0	0	0	0	0	0
1600	808	0	0	1	0	0	7	108	316	281	75	15	4	0	1	0	0	0	0	0	0	0	0	0	0	0	0	0
1700	819	0	0	0	1	3	10	127	303	260	87	18	6	3	0	0	0	1	0	0	0	0	0	0	0	0	0	0
1800	597	0	0	0	0	0	7	106	215	191	59	14	3	0	1	0	0	1	0	0	0	0	0	0	0	0	0	0
1900	493	0	0	1	2	4	7	78	189	159	36	14	1	2	0	0	0	0	0	0	0	0	0	0	0	0	0	0
2000	312	0	0	0	2	2	2	13	100	122	58	7	2	3	1	0	0	0	0	0	0	0	0	0	0	0	0	0
2100	234	0	0	0	1	0	0	20	80	81	23	14	9	2	2	0	1	0	0	0	1	0	0	0	0	0	0	0
2200	109	0	0	0	0	0	0	1	22	37	29	10	7	2	1	0	0	0	0	0	0	0	0	0	0	0	0	0
2300	63	0	0	0	0	0	0	1	20	18	8	11	1	2	1	0	1	0	0	0	0	0	0	0	0	0	0	0
07-19	8656	6	63	77	70	53	261	1368	3442	2425	658	170	44	12	4	1	0	2	0	0	0	0	0	0	0	0	0	0
06-22	10259	6	63	79	75	59	270	1520	4017	2997	846	229	65	20	8	1	1	2	0	0	1	0	0	0	0	0	0	0
06-00	10431	6	63	79	75	59	270	1522	4059	3052	883	250	73	24	10	1	2	2	0	0	1	0	0	0	0	0	0	0
00-00	10730	6	63	79	75	59	270	1529	4099	3140	972	293	91	31	15	2	3	2	0	0	1	0	0	0	0	0	0	0

Site 2
 Location Oxford Road, Att - L/C, OSGR: SP 46884 37469
 Direction Southbound

8643 / Bodicote Business Park, Banbury
 September 2018
 Automatic Traffic Count

Virtual Day (7)

Time	Total	Speed Bins (mph)																										
		0 - 5	5 - 10	10 - 15	15 - 20	20 - 25	25 - 30	30 - 35	35 - 40	40 - 45	45 - 50	50 - 55	55 - 60	60 - 65	65 - 70	70 - 75	75 - 80	80 - 85	85 - 90	90 - 95	95 - 100	100 - 105	105 - 110	110 - 115	115 - 120	120 - 125	125 - 130	130 - 135
0000	37	0	0	0	0	0	0	2	9	9	9	5	2	1	0	0	0	0	0	0	0	0	0	0	0	0	0	0
0100	28	0	0	0	0	0	0	1	4	6	8	4	3	2	1	0	0	0	0	0	0	0	0	0	0	0	0	0
0200	28	0	0	0	0	0	0	1	4	8	7	4	2	1	0	0	0	0	0	0	0	0	0	0	0	0	0	0
0300	29	0	0	0	0	0	0	1	3	5	8	6	4	2	0	0	0	0	0	0	0	0	0	0	0	0	0	0
0400	38	0	0	0	0	0	0	1	6	9	7	7	5	2	1	0	0	0	0	0	0	0	0	0	0	0	0	0
0500	142	0	0	0	0	0	1	4	22	47	34	18	7	4	2	1	0	0	0	0	0	0	0	0	0	0	0	0
0600	445	0	0	0	0	0	1	35	155	153	69	21	7	4	1	0	0	0	0	0	0	0	0	0	0	0	0	0
0700	802	2	9	13	8	6	28	154	317	185	56	15	5	1	1	0	0	0	0	0	0	0	0	0	0	0	0	0
0800	737	1	19	27	24	17	19	98	264	193	55	14	5	0	0	0	0	0	0	0	0	0	0	0	0	0	0	0
0900	559	0	0	1	1	2	6	62	221	188	54	17	4	1	1	0	0	0	0	0	0	0	0	0	0	0	0	0
1000	585	0	0	1	1	2	9	78	240	183	55	12	3	1	1	0	0	0	0	0	0	0	0	0	0	0	0	0
1100	649	0	0	0	2	4	12	110	284	178	44	11	3	1	0	0	0	0	0	0	0	0	0	0	0	0	0	0
1200	706	0	0	1	1	2	15	115	302	197	55	13	3	1	1	0	0	0	0	0	0	0	0	0	0	0	0	0
1300	679	0	0	0	0	2	14	104	289	196	57	11	4	1	0	0	0	0	0	0	0	0	0	0	0	0	0	0
1400	669	0	0	0	1	0	10	94	289	196	53	18	4	2	1	0	0	0	0	0	0	0	0	0	0	0	0	0
1500	719	0	0	1	3	2	15	117	301	205	56	13	3	1	1	0	0	0	0	0	0	0	0	0	0	0	0	0
1600	775	0	0	1	1	2	16	107	308	250	68	15	5	2	0	0	0	0	0	0	0	0	0	0	0	0	0	0
1700	750	0	1	1	3	4	10	93	303	239	73	16	5	2	1	0	0	0	0	0	0	0	0	0	0	0	0	0
1800	540	0	0	0	0	2	7	63	199	184	62	16	5	0	0	0	0	0	0	0	0	0	0	0	0	0	0	0
1900	450	0	0	0	1	1	5	61	184	137	42	13	4	1	1	0	0	0	0	0	0	0	0	0	0	0	0	0
2000	297	0	0	0	0	1	2	24	111	101	42	10	4	2	0	0	0	0	0	0	0	0	0	0	0	0	0	0
2100	200	0	0	0	0	0	2	13	67	68	28	14	4	1	1	0	0	0	0	0	0	0	0	0	0	0	0	0
2200	113	0	0	0	0	0	0	5	29	38	25	9	3	1	1	0	0	0	0	0	0	0	0	0	0	0	0	0
2300	74	0	0	0	0	0	0	4	17	24	15	8	2	1	1	0	0	0	0	0	0	0	0	0	0	0	0	0
07-19	8171	4	29	47	45	44	160	1196	3316	2395	688	171	51	13	7	2	1	1	0	0	0	0	0	0	0	0	0	0
06-22	9564	4	29	48	47	46	169	1328	3833	2854	870	229	70	21	10	3	1	1	1	0	0	0	0	0	0	0	0	0
06-00	9751	4	29	48	47	46	170	1337	3879	2917	910	246	75	23	12	4	2	1	1	0	0	0	0	0	0	0	0	0
00-00	10053	4	29	48	47	46	171	1346	3929	3001	982	290	99	34	16	5	3	2	1	0	0	0	0	0	0	0	0	0

Site 2
 Location Oxford Road, Att - L/C, OSGR: SP 46884 37469
 Direction Southbound

8643 / Bodicote Business Park, Banbury
 September 2018
 Automatic Traffic Count

Virtual Week (1)

Time	Total	Speed Bins (mph)																												
		0 - 5	5 - 10	10 - 15	15 - 20	20 - 25	25 - 30	30 - 35	35 - 40	40 - 45	45 - 50	50 - 55	55 - 60	60 - 65	65 - 70	70 - 75	75 - 80	80 - 85	85 - 90	90 - 95	95 - 100	100 - 105	105 - 110	110 - 115	115 - 120	120 - 125	125 - 130	130 - 135	135 - 140	
Mon	10520	13	109	163	123	128	207	1436	4040	3028	889	242	85	28	14	8	4	3	0	0	0	0	0	0	0	0	0	0	0	0
Tue	10730	6	63	79	75	59	270	1529	4099	3140	972	293	91	31	15	2	3	2	0	0	1	0	0	0	0	0	0	0	0	
Wed	10967	2	3	13	17	24	163	1500	4448	3289	1061	289	95	46	10	6	0	0	0	1	0	0	0	0	0	0	0	0	0	
Thu	11102	5	22	57	52	46	196	1464	4409	3302	1108	283	99	39	12	2	4	0	0	0	0	1	1	0	0	0	0	0	0	
Fri	11204	1	6	15	32	32	161	1710	4532	3230	997	319	101	32	22	7	4	2	1	0	0	0	0	0	0	0	0	0	0	
Sat	8783	0	0	8	22	23	113	989	3412	2755	977	305	119	29	20	6	2	1	2	0	0	0	0	0	0	0	0	0	0	
Sun	7064	0	0	3	8	12	87	796	2560	2261	873	297	100	33	22	5	3	3	1	0	0	0	0	0	0	0	0	0	0	
5 Day Ave.	10905	5	41	65	60	58	199	1528	4306	3198	1005	285	94	35	15	5	3	1	0	0	0	0	0	0	0	0	0	0	0	
7 Day Ave.	10053	4	29	48	47	46	171	1346	3929	3001	982	290	99	34	16	5	3	2	1	0	0	0	0	0	0	0	0	0	0	
--	70370	27	203	338	329	324	1197	9424	27500	21005	6877	2028	690	238	115	36	20	11	4	1	1	1	1	0	0	0	0	0	0	

Summary Graphs

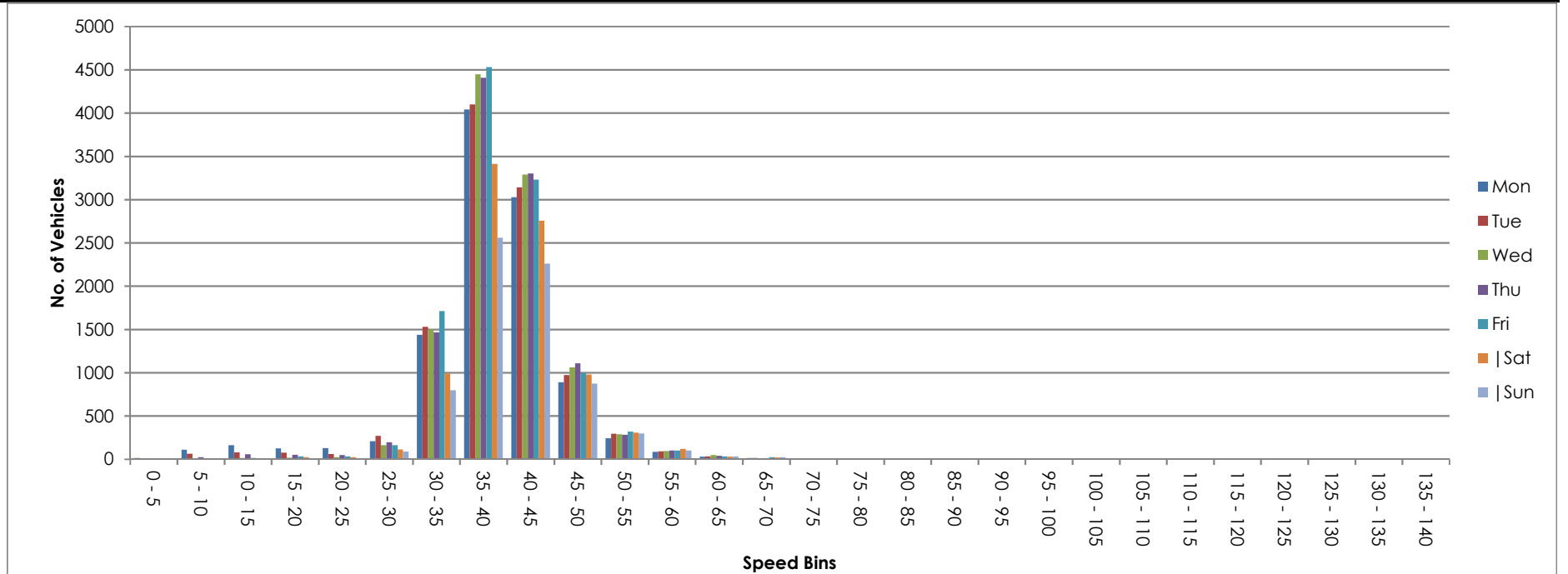

Site 2
 Location Oxford Road, Att - L/C, OSGR: SP 46884 37469
 Direction Two way

8643 / Bodicote Business Park, Banbury
 September 2018
 Automatic Traffic Count

26 September 2018

Time	Total	Classification												>PSL 40	>PSL% 40	>SL1 46 ACPO	>SL1% 46 ACPO	>SL2 55 DfT	>SL2% 55 DfT	Mean	Vpp 85
		1 MCL	2 SV	3 SVT	4 TB2	5 TB3	6 T4	7 ART3	8 ART4	9 ART5	10 ART6	11 BD	12 DRT								
0000	57	1	48	0	3	0	0	0	1	3	1	0	0	44	77.2	25	43.9	7	12.3	46	53.2
0100	45	2	32	0	9	0	0	0	1	1	0	0	0	38	84.4	20	44.4	10	22.2	47.2	56.4
0200	53	0	40	0	7	0	0	0	1	5	0	0	0	43	81.1	22	41.5	7	13.2	46	52.8
0300	59	0	52	0	5	0	1	0	0	1	0	0	0	49	83.1	32	54.2	15	25.4	48.3	57.5
0400	67	0	49	0	12	0	1	0	1	2	2	0	0	52	77.6	36	53.7	10	14.9	46.8	53.7
0500	252	4	227	0	16	1	1	0	1	1	1	0	0	199	79	100	39.7	29	11.5	45.6	52.6
0600	855	11	766	3	63	2	1	0	2	3	2	1	1	455	53.2	146	17.1	23	2.7	41.2	46.5
0700	1662	14	1477	9	138	5	8	1	1	2	7	0	0	494	29.7	93	5.6	3	0.2	37.6	42.3
0800	1687	10	1548	6	104	4	5	1	3	1	4	1	0	561	33.3	91	5.4	3	0.2	38.7	42.7
0900	1350	8	1230	4	95	1	2	0	4	5	0	0	1	478	35.4	82	6.1	5	0.4	38.8	42.7
1000	1197	8	1055	2	114	4	4	1	2	2	4	0	1	445	37.2	77	6.4	7	0.6	38.9	42.9
1100	1232	14	1098	5	96	8	6	0	1	2	2	0	0	380	30.8	65	5.3	5	0.4	38.4	42.5
1200	1284	16	1151	9	86	4	10	0	4	1	2	0	1	412	32.1	63	4.9	7	0.5	38.3	42.3
1300	1307	7	1174	7	95	3	10	1	4	4	2	0	0	460	35.2	69	5.3	5	0.4	38.6	42.9
1400	1450	13	1305	8	105	8	4	0	1	1	5	0	0	534	36.8	82	5.7	6	0.4	39	42.9
1500	1487	9	1366	4	92	3	3	0	2	4	2	1	1	525	35.3	66	4.4	4	0.3	38.6	42.7
1600	1783	18	1624	13	114	7	2	0	2	0	3	0	0	568	31.9	92	5.2	6	0.3	38.1	42.7
1700	1875	10	1784	13	55	2	3	0	2	2	3	0	1	587	31.3	100	5.3	13	0.7	37.4	42.5
1800	1525	18	1450	8	35	2	6	2	1	1	1	0	1	307	20.1	50	3.3	8	0.5	29.3	41.2
1900	1037	11	992	0	29	0	2	0	1	1	1	0	0	319	30.8	67	6.5	4	0.4	38.5	42.3
2000	756	9	710	0	33	0	1	0	0	1	2	0	0	307	40.6	66	8.7	8	1.1	39.5	44.1
2100	475	6	447	2	15	0	2	0	0	3	0	0	0	219	46.1	75	15.8	10	2.1	40.4	46.1
2200	261	4	244	0	9	0	0	0	0	3	1	0	0	163	62.5	64	24.5	15	5.7	42.7	48.3
2300	164	1	153	1	7	0	0	0	1	1	0	0	0	102	62.2	57	34.8	13	7.9	43.6	50.1
07-19	17839	145	16262	88	1129	51	63	6	27	25	35	2	6	5751	32.2	930	5.2	72	0.4	37.6	42.5
06-22	20962	182	19177	93	1269	53	69	6	30	33	40	3	7	7051	33.6	1284	6.1	117	0.6	37.9	42.9
06-00	21387	187	19574	94	1285	53	69	6	31	37	41	3	7	7316	34.2	1405	6.6	145	0.7	38	42.9
00-00	21920	194	20022	94	1337	54	72	6	36	50	45	3	7	7741	35.3	1640	7.5	223	1	38.2	43.2

Site 2
 Location Oxford Road, Att - L/C, OSGR: SP 46884 37469
 Direction Two way

8643 / Bodicote Business Park, Banbury
 September 2018
 Automatic Traffic Count

27 September 2018

Time	Total	Classification												>PSL 40	>PSL% 40	>SL1 46 ACPO	>SL1% 46 ACPO	>SL2 55 DfT	>SL2% 55 DfT	Mean	Vpp 85
		1 MCL	2 SV	3 SVT	4 TB2	5 TB3	6 T4	7 ART3	8 ART4	9 ART5	10 ART6	11 BD	12 DRT								
0000	69	2	53	0	7	0	0	0	2	4	1	0	0	55	79.7	32	46.4	16	23.2	47.1	57.7
0100	39	1	29	0	5	0	0	0	1	3	0	0	0	32	82.1	20	51.3	8	20.5	47.3	55.3
0200	61	0	55	0	3	0	0	0	1	2	0	0	0	53	86.9	27	44.3	7	11.5	46.4	54.4
0300	56	0	40	0	13	0	0	0	0	3	0	0	0	44	78.6	34	60.7	13	23.2	48	57.9
0400	61	1	49	0	9	0	0	0	1	0	1	0	0	49	80.3	31	50.8	7	11.5	46.3	52.8
0500	276	3	243	1	22	3	1	1	1	0	1	0	0	192	69.6	93	33.7	17	6.2	44	51
0600	823	5	723	4	77	1	4	0	3	3	1	2	0	441	53.6	125	15.2	18	2.2	41.3	46.1
0700	1677	17	1505	18	118	8	9	0	1	0	0	0	1	540	32.2	109	6.5	10	0.6	37.9	42.7
0800	1743	13	1597	6	96	13	10	0	1	1	6	0	0	472	27.1	75	4.3	3	0.2	35.8	41.8
0900	1439	6	1313	6	90	5	12	0	1	4	2	0	0	404	28.1	73	5.1	8	0.6	37	42.1
1000	1206	6	1077	4	105	5	1	0	4	1	3	0	0	468	38.8	74	6.1	4	0.3	39.2	43.2
1100	1256	11	1117	5	103	6	6	0	2	3	2	1	0	512	40.8	97	7.7	7	0.6	39.2	43.8
1200	1284	10	1157	4	90	2	6	3	4	4	3	1	0	566	44.1	104	8.1	11	0.9	39.7	44.1
1300	1325	14	1187	5	102	4	4	0	1	3	4	0	1	509	38.4	87	6.6	7	0.5	39.4	43.4
1400	1378	11	1231	7	110	4	6	0	2	2	5	0	0	497	36.1	103	7.5	12	0.9	38.8	43.2
1500	1543	15	1388	6	110	3	16	0	3	0	0	0	2	640	41.5	102	6.6	12	0.8	39.1	43.4
1600	1743	20	1580	12	113	7	2	0	3	2	4	0	0	632	36.3	98	5.6	13	0.7	37.5	43.2
1700	1874	12	1768	13	66	4	4	0	2	3	0	1	1	568	30.3	104	5.5	6	0.3	37.1	42.5
1800	1481	24	1400	9	40	2	0	0	1	4	1	0	0	563	38	109	7.4	11	0.7	38.9	43.4
1900	1102	12	1045	1	40	0	2	0	1	0	1	0	0	350	31.8	66	6	7	0.6	38.4	42.5
2000	674	8	637	0	25	0	1	0	1	0	2	0	0	269	39.9	55	8.2	4	0.6	39.4	43.8
2100	455	6	425	1	21	0	0	0	0	2	0	0	0	232	51	70	15.4	4	0.9	40.6	45.9
2200	303	4	284	2	10	0	0	0	1	2	0	0	0	149	49.2	59	19.5	10	3.3	41.5	47.4
2300	134	2	122	0	9	0	0	0	0	1	0	0	0	92	68.7	39	29.1	7	5.2	43.4	49.4
07-19	17949	159	16320	95	1143	63	76	3	25	27	30	3	5	6371	35.5	1135	6.3	104	0.6	38.2	42.9
06-22	21003	190	19150	101	1306	64	83	3	30	32	34	5	5	7663	36.5	1451	6.9	137	0.7	38.4	43.2
06-00	21440	196	19556	103	1325	64	83	3	31	35	34	5	5	7904	36.9	1549	7.2	154	0.7	38.5	43.4
00-00	22002	203	20025	104	1384	67	84	4	37	47	37	5	5	8329	37.9	1786	8.1	222	1	38.7	43.6

Site 2
 Location Oxford Road, Att - L/C, OSGR: SP 46884 37469
 Direction Two way

8643 / Bodicote Business Park, Banbury
 September 2018
 Automatic Traffic Count

28 September 2018

Time	Total	Classification												>PSL 40	>PSL% 40	>SL1 46 ACPO	>SL1% 46 ACPO	>SL2 55 DfT	>SL2% 55 DfT	Mean	Vpp 85
		1 MCL	2 SV	3 SVT	4 TB2	5 TB3	6 T4	7 ART3	8 ART4	9 ART5	10 ART6	11 BD	12 DRT								
0000	83	0	70	0	7	0	0	0	3	2	1	0	0	60	72.3	38	45.8	4	4.8	44.3	49.9
0100	62	4	43	0	8	0	0	0	2	4	1	0	0	47	75.8	28	45.2	9	14.5	46.1	54.8
0200	66	1	50	0	10	0	1	0	2	2	0	0	0	50	75.8	22	33.3	3	4.5	44.3	49.9
0300	55	1	47	0	6	0	0	0	0	0	1	0	0	47	85.5	33	60	10	18.2	48.1	57.7
0400	61	0	46	0	13	0	0	0	1	0	1	0	0	44	72.1	31	50.8	12	19.7	46.6	55.7
0500	293	3	262	0	23	1	0	0	2	2	0	0	0	176	60.1	81	27.6	16	5.5	42.6	49.4
0600	775	10	682	1	68	2	3	0	3	5	1	0	0	426	55	129	16.6	11	1.4	41.3	46.3
0700	1517	15	1365	7	118	2	1	1	2	1	4	1	0	525	34.6	108	7.1	14	0.9	38.8	42.9
0800	1711	11	1553	9	120	5	3	0	0	3	3	3	1	538	31.4	73	4.3	8	0.5	37.4	42.3
0900	1367	3	1239	8	102	3	4	0	4	1	3	0	0	359	26.3	72	5.3	5	0.4	35.6	42.1
1000	1347	6	1211	8	104	4	5	0	3	2	4	0	0	441	32.7	66	4.9	4	0.3	38.5	42.7
1100	1358	12	1215	8	109	7	4	0	0	1	2	0	0	394	29	72	5.3	2	0.1	37.8	42.3
1200	1474	16	1334	10	100	6	3	0	0	3	2	0	0	465	31.5	73	5	7	0.5	38	42.3
1300	1462	7	1313	2	116	2	3	2	7	6	2	1	1	464	31.7	74	5.1	9	0.6	38.4	42.7
1400	1564	7	1428	7	105	3	5	0	3	2	4	0	0	536	34.3	98	6.3	6	0.4	38.8	42.5
1500	1697	16	1537	9	114	5	7	2	2	1	3	0	1	444	26.2	75	4.4	10	0.6	35.6	41.8
1600	1936	17	1795	12	105	1	2	0	1	2	1	0	0	599	30.9	75	3.9	7	0.4	37.1	42.3
1700	1846	12	1758	6	61	3	1	3	0	0	2	0	0	699	37.9	106	5.7	11	0.6	38.2	43.2
1800	1547	10	1470	7	51	0	1	0	3	4	1	0	0	519	33.5	102	6.6	8	0.5	37.3	42.9
1900	1021	2	981	3	28	0	1	0	3	3	0	0	0	351	34.4	85	8.3	9	0.9	39.1	43.2
2000	679	5	650	3	19	0	0	0	0	2	0	0	0	341	50.2	96	14.1	10	1.5	40.6	45.4
2100	424	6	394	1	20	0	0	0	1	1	1	0	0	221	52.1	71	16.7	15	3.5	41.6	46.1
2200	310	2	286	1	19	0	0	0	0	2	0	0	0	204	65.8	88	28.4	17	5.5	43.5	49.2
2300	203	1	194	0	5	0	0	0	2	1	0	0	0	146	71.9	59	29.1	13	6.4	44	50.1
07-19	18826	132	17218	93	1205	41	39	8	25	26	31	5	3	5983	31.8	994	5.3	91	0.5	37.6	42.5
06-22	21725	155	19925	101	1340	43	43	8	32	37	33	5	3	7322	33.7	1375	6.3	136	0.6	38	42.9
06-00	22238	158	20405	102	1364	43	43	8	34	40	33	5	3	7672	34.5	1522	6.8	166	0.7	38.1	43.2
00-00	22858	167	20923	102	1431	44	44	8	44	50	37	5	3	8096	35.4	1755	7.7	220	1	38.3	43.4



Site 2
 Location Oxford Road, Att - L/C, OSGR: SP 46884 37469
 Direction Two way

8643 / Bodicote Business Park, Banbury
 September 2018
 Automatic Traffic Count

29 September 2018

Time	Total	Classification												>PSL 40	>PSL% 40	>SL1 46 ACPO	>SL1% 46 ACPO	>SL2 55 DfT	>SL2% 55 DfT	Mean	Vpp 85
		1 MCL	2 SV	3 SVT	4 TB2	5 TB3	6 T4	7 ART3	8 ART4	9 ART5	10 ART6	11 BD	12 DRT								
0000	125	2	110	1	8	0	0	0	3	1	0	0	0	91	72.8	43	34.4	8	6.4	44.5	52.8
0100	84	1	72	0	9	0	0	1	1	0	0	0	0	66	78.6	48	57.1	12	14.3	47.2	54.8
0200	72	0	63	0	6	0	0	0	2	1	0	0	0	52	72.2	32	44.4	12	16.7	46.2	55.7
0300	56	1	42	0	11	0	0	1	0	1	0	0	0	45	80.4	29	51.8	9	16.1	46.7	55.3
0400	58	0	50	1	6	0	0	0	1	0	0	0	0	46	79.3	32	55.2	13	22.4	47.9	56.6
0500	134	2	114	0	15	1	1	0	0	0	1	0	0	107	79.9	62	46.3	26	19.4	46.9	55.5
0600	233	2	199	1	28	0	2	0	1	0	0	0	0	165	70.8	72	30.9	16	6.9	43.9	49.9
0700	497	7	442	0	47	1	0	0	0	0	0	0	0	313	63	121	24.3	25	5	42.8	48.1
0800	875	5	792	3	65	3	2	0	1	1	2	1	0	472	53.9	97	11.1	11	1.3	40.6	45
0900	1205	13	1124	6	60	0	1	0	0	0	1	0	0	460	38.2	77	6.4	7	0.6	39	43.2
1000	1349	11	1277	10	41	3	1	0	1	1	2	0	2	484	35.9	100	7.4	8	0.6	38.3	42.9
1100	1399	11	1334	5	40	3	3	0	1	2	0	0	0	487	34.8	98	7	10	0.7	38.6	42.9
1200	1527	18	1443	8	48	6	1	0	0	0	3	0	0	539	35.3	115	7.5	4	0.3	37.2	43.4
1300	1474	18	1403	5	43	1	2	0	2	0	0	0	0	512	34.7	114	7.7	8	0.5	38.7	43.2
1400	1354	24	1277	4	42	0	4	0	1	0	2	0	0	477	35.2	95	7	9	0.7	38.9	43.2
1500	1316	24	1238	8	39	0	6	0	0	0	0	0	1	494	37.5	92	7	8	0.6	38.9	43.2
1600	1293	26	1221	7	36	1	1	0	0	1	0	0	0	590	45.6	110	8.5	14	1.1	39.8	44.3
1700	1267	14	1211	5	33	2	0	0	1	0	1	0	0	575	45.4	133	10.5	10	0.8	40.1	44.1
1800	981	7	939	2	31	0	1	0	1	0	0	0	0	497	50.7	102	10.4	10	1	40.3	44.7
1900	742	6	705	1	30	0	0	0	0	0	0	0	0	347	46.8	81	10.9	9	1.2	40.4	44.7
2000	468	2	446	1	19	0	0	0	0	0	0	0	0	223	47.6	63	13.5	7	1.5	40.3	45.4
2100	399	3	388	0	8	0	0	0	0	0	0	0	0	207	51.9	71	17.8	10	2.5	41.3	46.8
2200	316	1	309	0	6	0	0	0	0	0	0	0	0	195	61.7	68	21.5	6	1.9	42.3	47.2
2300	241	1	230	0	10	0	0	0	0	0	0	0	0	156	64.7	69	28.6	13	5.4	43.3	49.7
07-19	14537	178	13701	63	525	20	22	0	8	5	11	1	3	5900	40.6	1254	8.6	124	0.9	39.2	43.8
06-22	16379	191	15439	66	610	20	24	0	9	5	11	1	3	6842	41.8	1541	9.4	166	1	39.4	44.1
06-00	16936	193	15978	66	626	20	24	0	9	5	11	1	3	7193	42.5	1678	9.9	185	1.1	39.5	44.3
00-00	17465	199	16429	68	681	21	25	2	16	8	12	1	3	7600	43.5	1924	11	265	1.5	39.7	44.5

Site 2
 Location Oxford Road, Att - L/C, OSGR: SP 46884 37469
 Direction Two way

8643 / Bodicote Business Park, Banbury
 September 2018
 Automatic Traffic Count

30 September 2018

Time	Total	Classification												>PSL 40	>PSL% 40	>SL1 46 ACPO	>SL1% 46 ACPO	>SL2 55 DfT	>SL2% 55 DfT	Mean	Vpp 85
		1 MCL	2 SV	3 SVT	4 TB2	5 TB3	6 T4	7 ART3	8 ART4	9 ART5	10 ART6	11 BD	12 DRT								
0000	143	1	123	1	18	0	0	0	0	0	0	0	0	95	66.4	65	45.5	12	8.4	44.5	52.1
0100	118	2	105	0	11	0	0	0	0	0	0	0	0	84	71.2	50	42.4	15	12.7	45.3	53.7
0200	88	1	81	0	5	1	0	0	0	0	0	0	0	69	78.4	44	50	13	14.8	46.5	54.6
0300	60	1	49	0	10	0	0	0	0	0	0	0	0	51	85	39	65	14	23.3	49.2	58.8
0400	63	3	53	0	7	0	0	0	0	0	0	0	0	51	81	37	58.7	13	20.6	48.9	56.6
0500	73	3	60	1	8	0	0	0	1	0	0	0	0	55	75.3	29	39.7	10	13.7	45.7	53.7
0600	158	0	142	1	15	0	0	0	0	0	0	0	0	117	74.1	48	30.4	10	6.3	44.1	50.8
0700	293	6	267	3	15	2	0	0	0	0	0	0	0	212	72.4	90	30.7	20	6.8	44	50.1
0800	529	14	478	3	32	0	1	0	0	0	1	0	0	343	64.8	113	21.4	14	2.6	42.2	47.2
0900	814	19	760	4	29	0	2	0	0	0	0	0	0	391	48	99	12.2	9	1.1	40.1	45
1000	1191	24	1119	6	41	0	1	0	0	0	0	0	0	449	37.7	77	6.5	6	0.5	38.9	42.9
1100	1242	23	1166	6	40	3	2	1	0	0	0	0	1	432	34.8	65	5.2	5	0.4	38.5	42.9
1200	1444	33	1352	12	36	5	1	0	2	0	1	2	0	466	32.3	78	5.4	7	0.5	37.9	42.3
1300	1328	16	1266	3	34	1	2	0	2	1	3	0	0	463	34.9	90	6.8	11	0.8	38.8	42.9
1400	1207	28	1143	3	26	0	4	0	3	0	0	0	0	492	40.8	98	8.1	10	0.8	39.4	43.8
1500	1182	14	1125	8	30	1	1	0	1	0	1	0	1	453	38.3	95	8	9	0.8	39.1	43.6
1600	1071	21	994	8	44	0	1	0	2	0	1	0	0	520	48.6	94	8.8	11	1	39.9	44.3
1700	892	6	847	5	25	0	2	2	3	0	2	0	0	480	53.8	123	13.8	14	1.6	40.8	45.6
1800	742	9	694	4	33	0	2	0	0	0	0	0	0	408	55	115	15.5	13	1.8	41.2	46.1
1900	577	2	550	1	24	0	0	0	0	0	0	0	0	299	51.8	92	15.9	11	1.9	41.1	46.1
2000	389	1	372	0	15	0	0	0	0	0	1	0	0	217	55.8	82	21.1	11	2.8	42	47.9
2100	286	1	273	0	12	0	0	0	0	0	0	0	0	157	54.9	58	20.3	9	3.1	41.8	47.2
2200	167	0	159	0	8	0	0	0	0	0	0	0	0	98	58.7	51	30.5	12	7.2	42.9	49.4
2300	99	0	95	0	4	0	0	0	0	0	0	0	0	57	57.6	31	31.3	7	7.1	43.5	51
07-19	11935	213	11211	65	385	12	19	3	13	1	9	2	2	5109	42.8	1137	9.5	129	1.1	39.5	44.3
06-22	13345	217	12548	67	451	12	19	3	13	1	10	2	2	5899	44.2	1417	10.6	170	1.3	39.8	44.5
06-00	13611	217	12802	67	463	12	19	3	13	1	10	2	2	6054	44.5	1499	11	189	1.4	39.8	44.7
00-00	14156	228	13273	69	522	13	19	3	14	1	10	2	2	6459	45.6	1763	12.5	266	1.9	40.1	45



Site 2
 Location Oxford Road, Att - L/C, OSGR: SP 46884 37469
 Direction Two way

8643 / Bodicote Business Park, Banbury
 September 2018
 Automatic Traffic Count

01 October 2018

Time	Total	Classification												>PSL 40	>PSL% 40	>SL1 46 ACPO	>SL1% 46 ACPO	>SL2 55 DfT	>SL2% 55 DfT	Mean	Vpp 85
		1 MCL	2 SV	3 SVT	4 TB2	5 TB3	6 T4	7 ART3	8 ART4	9 ART5	10 ART6	11 BD	12 DRT								
0000	38	1	33	0	4	0	0	0	0	0	0	0	0	26	68.4	14	36.8	5	13.2	44.4	52.1
0100	38	1	29	0	8	0	0	0	0	0	0	0	0	31	81.6	20	52.6	8	21.1	48.4	57.5
0200	48	3	37	0	4	0	0	0	0	1	3	0	0	32	66.7	22	45.8	6	12.5	45.8	53.7
0300	54	0	41	0	10	1	0	0	0	0	1	1	0	42	77.8	30	55.6	12	22.2	47.2	57.9
0400	75	1	60	0	12	0	0	0	0	1	1	0	0	58	77.3	36	48	17	22.7	47.3	57.3
0500	257	3	221	0	26	1	1	0	1	3	1	0	0	192	74.7	94	36.6	19	7.4	44.8	51.4
0600	777	7	699	0	58	0	2	2	1	5	3	0	0	404	52	113	14.5	11	1.4	40.9	45.6
0700	1656	20	1522	6	88	5	5	0	4	1	3	1	1	452	27.3	69	4.2	10	0.6	35.5	42.1
0800	1698	9	1580	6	78	11	6	2	0	2	3	0	1	428	25.2	62	3.7	3	0.2	33.6	41.6
0900	1290	8	1190	2	85	1	1	0	0	1	2	0	0	374	29	72	5.6	9	0.7	37.7	42.1
1000	1216	6	1082	4	108	6	1	1	1	4	3	0	0	420	34.5	58	4.8	5	0.4	38.5	42.7
1100	1189	4	1048	7	118	6	2	0	0	3	1	0	0	399	33.6	66	5.6	5	0.4	38.5	42.5
1200	1186	9	1072	3	86	5	3	1	2	1	3	0	1	489	41.2	90	7.6	7	0.6	39.2	43.4
1300	1281	7	1159	5	92	6	2	0	2	4	4	0	0	473	36.9	66	5.2	5	0.4	38.7	42.7
1400	1320	9	1186	5	109	5	1	0	0	1	3	0	1	415	31.4	80	6.1	7	0.5	38.5	42.7
1500	1446	6	1310	5	108	3	3	1	4	1	4	1	0	518	35.8	80	5.5	4	0.3	38.4	42.9
1600	1708	21	1578	6	86	7	3	0	1	1	4	1	0	615	36	89	5.2	5	0.3	38.8	42.9
1700	1861	16	1743	15	73	5	3	2	0	0	2	1	1	478	25.7	82	4.4	5	0.3	36	41.6
1800	1423	10	1349	9	50	1	1	0	1	0	2	0	0	471	33.1	72	5.1	2	0.1	38	42.9
1900	1001	5	959	1	34	0	0	0	1	0	1	0	0	345	34.5	46	4.6	7	0.7	38.5	42.3
2000	511	5	484	0	19	0	0	0	0	2	1	0	0	271	53	82	16	13	2.5	41.3	46.3
2100	372	6	353	1	11	0	0	0	0	1	0	0	0	181	48.7	55	14.8	8	2.2	40.4	45.6
2200	252	3	239	0	7	0	0	0	0	3	0	0	0	146	57.9	48	19	10	4	42.2	47.2
2300	105	1	99	0	3	0	0	0	1	1	0	0	0	71	67.6	31	29.5	8	7.6	43.8	50.6
07-19	17274	125	15819	73	1081	61	31	7	15	19	34	4	5	5532	32	886	5.1	67	0.4	37.4	42.5
06-22	19935	148	18314	75	1203	61	33	9	17	27	39	4	5	6733	33.8	1182	5.9	106	0.5	37.8	42.9
06-00	20292	152	18652	75	1213	61	33	9	18	31	39	4	5	6950	34.2	1261	6.2	124	0.6	37.9	42.9
00-00	20802	161	19073	75	1277	63	34	9	19	36	45	5	5	7331	35.2	1477	7.1	191	0.9	38.1	43.2

Site 2
 Location Oxford Road, Att - L/C, OSGR: SP 46884 37469
 Direction Two way

8643 / Bodicote Business Park, Banbury
 September 2018
 Automatic Traffic Count

02 October 2018

Time	Total	Classification												>PSL 40	>PSL% 40	>SL1 46 ACPO	>SL1% 46 ACPO	>SL2 55 DfT	>SL2% 55 DfT	Mean	Vpp 85
		1 MCL	2 SV	3 SVT	4 TB2	5 TB3	6 T4	7 ART3	8 ART4	9 ART5	10 ART6	11 BD	12 DRT								
0000	57	0	46	0	5	0	1	0	3	2	0	0	0	36	63.2	18	31.6	4	7	44.1	50.1
0100	39	4	24	0	7	0	0	0	1	2	1	0	0	30	76.9	20	51.3	5	12.8	45.8	51
0200	50	1	35	0	8	0	0	0	1	5	0	0	0	37	74	20	40	8	16	46.7	55.3
0300	56	0	47	0	8	0	0	0	0	0	1	0	0	46	82.1	37	66.1	12	21.4	49.1	57.7
0400	66	0	56	0	9	0	0	0	1	0	0	0	0	53	80.3	31	47	12	18.2	46.8	55
0500	257	1	228	0	18	4	0	0	2	1	3	0	0	207	80.5	96	37.4	16	6.2	45	51.4
0600	811	11	721	2	67	3	1	0	2	2	2	0	0	431	53.1	115	14.2	13	1.6	40.8	45.6
0700	1706	20	1533	8	113	16	6	0	3	4	2	0	1	471	27.6	68	4	5	0.3	36.3	41.8
0800	1782	8	1643	15	92	13	6	0	2	2	1	0	0	410	23	71	4	5	0.3	34.7	41.4
0900	1297	8	1151	11	97	10	13	0	1	2	3	0	1	502	38.7	78	6	6	0.5	38.6	42.9
1000	1223	7	1091	3	107	4	4	1	0	2	4	0	0	410	33.5	64	5.2	6	0.5	38.5	42.5
1100	1219	7	1083	4	108	8	5	0	2	2	0	0	0	343	28.1	47	3.9	4	0.3	37.6	41.8
1200	1249	5	1131	8	85	8	4	0	2	1	4	1	0	427	34.2	77	6.2	3	0.2	38.5	42.7
1300	1246	8	1107	11	106	5	3	0	2	1	2	0	1	430	34.5	83	6.7	9	0.7	38.6	43.2
1400	1336	9	1221	3	92	2	2	0	1	4	0	1	1	494	37	96	7.2	8	0.6	39.1	43.4
1500	1475	6	1339	4	113	5	4	0	1	2	1	0	0	498	33.8	90	6.1	7	0.5	38.4	42.9
1600	1698	15	1554	13	105	4	3	0	1	1	2	0	0	612	36	87	5.1	6	0.4	38.3	42.9
1700	1941	19	1810	13	82	5	7	2	1	1	1	0	0	609	31.4	113	5.8	10	0.5	36.6	42.9
1800	1506	13	1421	10	56	1	1	0	1	2	0	0	1	469	31.1	83	5.5	5	0.3	38.1	42.5
1900	1020	7	970	4	36	0	1	0	1	0	1	0	0	350	34.3	60	5.9	4	0.4	38.4	42.9
2000	611	1	584	2	23	0	0	0	0	1	0	0	0	351	57.4	79	12.9	9	1.5	41	45.6
2100	433	4	417	0	9	0	2	0	0	1	0	0	0	231	53.3	76	17.6	18	4.2	41.3	46.5
2200	230	5	219	0	5	0	0	0	0	1	0	0	0	158	68.7	68	29.6	14	6.1	43.5	49.2
2300	132	1	126	0	3	0	0	0	0	2	0	0	0	72	54.5	35	26.5	7	5.3	42.6	51.2
07-19	17678	125	16084	103	1156	81	58	3	17	24	20	2	5	5675	32.1	957	5.4	74	0.4	37.6	42.5
06-22	20553	148	18776	111	1291	84	62	3	20	28	23	2	5	7038	34.2	1287	6.3	118	0.6	38	42.9
06-00	20915	154	19121	111	1299	84	62	3	20	31	23	2	5	7268	34.8	1390	6.6	139	0.7	38.1	42.9
00-00	21440	160	19557	111	1354	88	63	3	28	41	28	2	5	7677	35.8	1612	7.5	196	0.9	38.3	43.2



Site 2
 Location Oxford Road, Att - L/C, OSGR: SP 46884 37469
 Direction Two way

8643 / Bodicote Business Park, Banbury
 September 2018
 Automatic Traffic Count

Virtual Day (7)

Time	Total	Classification												>PSL 40	>PSL% 40	>SL1 46 ACPO	>SL1% 46 ACPO	>SL2 55 DfT	>SL2% 55 DfT	Mean	Vpp 85
		1 MCL	2 SV	3 SVT	4 TB2	5 TB3	6 T4	7 ART3	8 ART4	9 ART5	10 ART6	11 BD	12 DRT								
0000	82	1	69	0	7	0	0	0	2	2	0	0	0	58	71.2	34	41.1	8	9.8	44.9	52.6
0100	61	2	48	0	8	0	0	0	1	1	0	0	0	47	77.2	29	48.5	10	15.8	46.5	55
0200	63	1	52	0	6	0	0	0	1	2	0	0	0	48	76.7	27	43.2	8	12.8	46	53.7
0300	57	0	45	0	9	0	0	0	0	1	0	0	0	46	81.8	33	59.1	12	21.5	48.1	57.9
0400	64	1	52	0	10	0	0	0	1	0	1	0	0	50	78.3	33	51.9	12	18.6	47.2	56.1
0500	220	3	194	0	18	2	1	0	1	1	1	0	0	161	73.2	79	36	19	8.6	44.6	51.7
0600	633	7	562	2	54	1	2	0	2	3	1	0	0	348	55	107	16.9	15	2.3	41.4	46.5
0700	1287	14	1159	7	91	6	4	0	2	1	2	0	0	430	33.4	94	7.3	12	1	37.7	42.9
0800	1432	10	1313	7	84	7	5	0	1	1	3	1	0	461	32.2	83	5.8	7	0.5	36.8	42.7
0900	1252	9	1144	6	80	3	5	0	1	2	2	0	0	424	33.9	79	6.3	7	0.6	37.9	42.9
1000	1247	10	1130	5	89	4	2	0	2	2	3	0	0	445	35.7	74	5.9	6	0.5	38.7	42.9
1100	1271	12	1152	6	88	6	4	0	1	2	1	0	0	421	33.1	73	5.7	5	0.4	38.4	42.7
1200	1350	15	1234	8	76	5	4	1	2	1	3	1	0	481	35.6	86	6.4	7	0.5	38.3	42.9
1300	1346	11	1230	5	84	3	4	0	3	3	2	0	0	473	35.1	83	6.2	8	0.6	38.7	42.9
1400	1373	14	1256	5	84	3	4	0	2	1	3	0	0	492	35.9	93	6.8	8	0.6	38.9	43.2
1500	1449	13	1329	6	87	3	6	0	2	1	2	0	1	510	35.2	86	5.9	8	0.5	38.2	42.9
1600	1605	20	1478	10	86	4	2	0	1	1	2	0	0	591	36.8	92	5.7	9	0.6	38.3	43.2
1700	1651	13	1560	10	56	3	3	1	1	1	2	0	0	571	34.6	109	6.6	10	0.6	37.7	43.2
1800	1315	13	1246	7	42	1	2	0	1	2	1	0	0	462	35.1	90	6.9	8	0.6	37.1	43.2
1900	929	6	886	2	32	0	1	0	1	1	1	0	0	337	36.3	71	7.6	7	0.8	39	43.2
2000	584	4	555	1	22	0	0	0	0	1	1	0	0	283	48.4	75	12.8	9	1.5	40.4	45.4
2100	406	5	385	1	14	0	1	0	0	1	0	0	0	207	50.9	68	16.7	11	2.6	41	46.5
2200	263	3	249	0	9	0	0	0	0	2	0	0	0	159	60.5	64	24.3	12	4.6	42.6	48.5
2300	154	1	146	0	6	0	0	0	1	1	0	0	0	99	64.6	46	29.8	10	6.3	43.5	50.3
07-19	16577	154	15231	83	946	47	44	4	19	18	24	3	4	5760	34.7	1042	6.3	94	0.6	38.1	42.9
06-22	19129	176	17618	88	1067	48	48	5	22	23	27	3	4	6935	36.3	1362	7.1	136	0.7	38.3	43.2
06-00	19546	180	18013	88	1082	48	48	5	22	26	27	3	4	7194	36.8	1472	7.5	157	0.8	38.4	43.4
00-00	20092	187	18472	89	1141	50	49	5	28	33	31	3	4	7605	37.8	1708	8.5	226	1.1	38.6	43.6



Site 2
 Location Oxford Road, Att - L/C, OSGR: SP 46884 37469
 Direction Two way

8643 / Bodicote Business Park, Banbury
 September 2018
 Automatic Traffic Count

Virtual Week (1)

Time	Total	Classification												>PSL 40	>PSL% 40	>SL1 46 ACPO	>SL1% 46 ACPO	>SL2 55 DfT	>SL2% 55 DfT	Mean	Vpp 85
		1 MCL	2 SV	3 SVT	4 TB2	5 TB3	6 T4	7 ART3	8 ART4	9 ART5	10 ART6	11 BD	12 DRT								
Mon	20802	161	19073	75	1277	63	34	9	19	36	45	5	5	7331	35.2	1477	7.1	191	0.9	38.1	43.2
Tue	21440	160	19557	111	1354	88	63	3	28	41	28	2	5	7677	35.8	1612	7.5	196	0.9	38.3	43.2
Wed	21920	194	20022	94	1337	54	72	6	36	50	45	3	7	7741	35.3	1640	7.5	223	1	38.2	43.2
Thu	22002	203	20025	104	1384	67	84	4	37	47	37	5	5	8329	37.9	1786	8.1	222	1	38.7	43.6
Fri	22858	167	20923	102	1431	44	44	8	44	50	37	5	3	8096	35.4	1755	7.7	220	1	38.3	43.4
Sat	17465	199	16429	68	681	21	25	2	16	8	12	1	3	7600	43.5	1924	11	265	1.5	39.7	44.5
Sun	14156	228	13273	69	522	13	19	3	14	1	10	2	2	6459	45.6	1763	12.5	266	1.9	40.1	45
5 Day Ave.	21804	177	19920	97	1357	63	59	6	33	45	38	4	5	7835	35.9	1654	7.6	210	1.0	38.3	43.3
7 Day Ave.	20092	187	18472	89	1141	50	49	5	28	33	31	3	4	7605	37.8	1708	8.5	226	1.1	38.6	43.6
--	140643	1312	129302	623	7986	350	341	35	194	233	214	23	30	53233	37.8	11957	8.5	1583	1.1	38.6	43.6

Summary Graphs

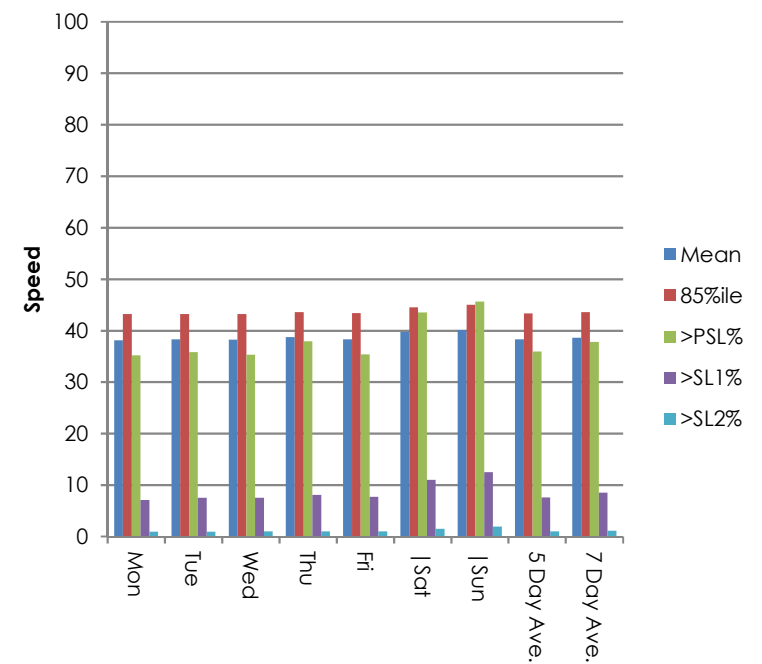
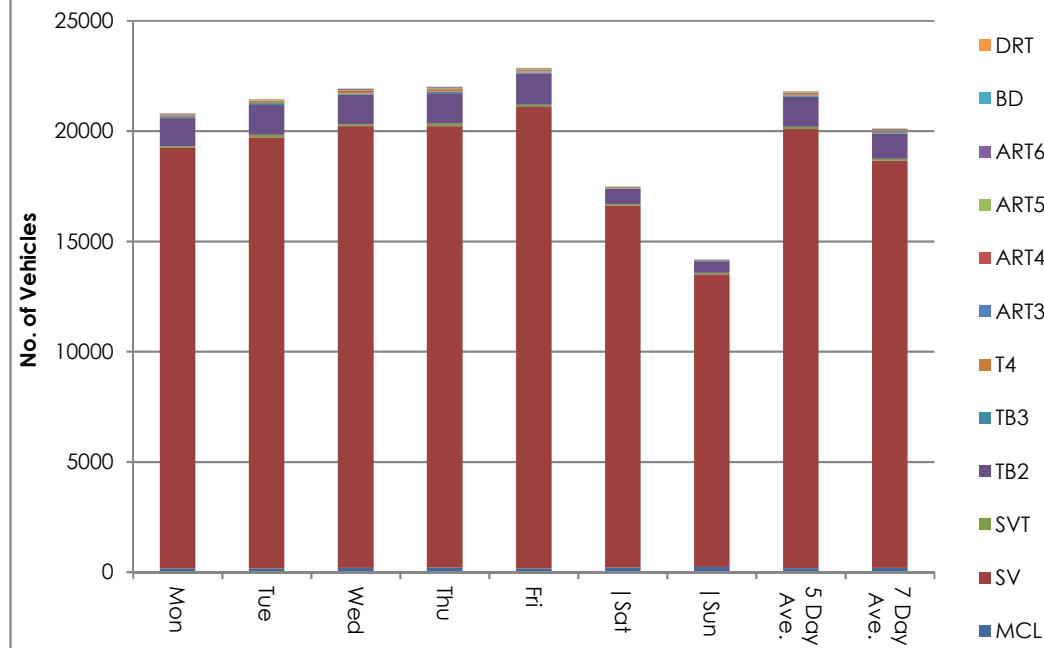

Site 2
 Location Oxford Road, Att - L/C, OSGR: SP 46884 37469
 Direction Two way

8643 / Bodicote Business Park, Banbury
 September 2018
 Automatic Traffic Count

26 September 2018

Time	Total	Speed Bins (mph)																											
		0 - 5	5 - 10	10 - 15	15 - 20	20 - 25	25 - 30	30 - 35	35 - 40	40 - 45	45 - 50	50 - 55	55 - 60	60 - 65	65 - 70	70 - 75	75 - 80	80 - 85	85 - 90	90 - 95	95 - 100	100 - 105	105 - 110	110 - 115	115 - 120	120 - 125	125 - 130	130 - 135	135 - 140
0000	57	0	0	0	0	0	0	2	11	14	13	10	5	1	0	1	0	0	0	0	0	0	0	0	0	0	0	0	
0100	45	0	0	0	0	0	0	1	6	16	7	5	5	5	0	0	0	0	0	0	0	0	0	0	0	0	0	0	
0200	53	0	0	0	0	0	0	2	8	15	13	8	5	0	2	0	0	0	0	0	0	0	0	0	0	0	0	0	
0300	59	0	0	0	0	0	0	1	9	13	14	7	9	5	1	0	0	0	0	0	0	0	0	0	0	0	0	0	
0400	67	0	0	0	0	0	0	3	12	14	15	13	4	3	3	0	0	0	0	0	0	0	0	0	0	0	0	0	
0500	252	0	0	0	1	0	1	12	39	87	51	32	12	14	1	2	0	0	0	0	0	0	0	0	0	0	0	0	
0600	855	0	0	0	4	2	7	71	316	262	138	32	14	8	0	1	0	0	0	0	0	0	0	0	0	0	0	0	
0700	1662	0	2	5	10	23	64	354	710	375	99	17	2	1	0	0	0	0	0	0	0	0	0	0	0	0	0	0	
0800	1687	0	0	0	1	3	18	270	834	431	102	25	3	0	0	0	0	0	0	0	0	0	0	0	0	0	0	0	
0900	1350	0	0	0	0	0	13	232	627	363	81	29	3	1	1	0	0	0	0	0	0	0	0	0	0	0	0	0	
1000	1197	0	0	3	0	4	18	188	539	345	74	19	4	2	0	1	0	0	0	0	0	0	0	0	0	0	0	0	
1100	1232	0	0	1	1	10	22	192	626	289	70	16	4	1	0	0	0	0	0	0	0	0	0	0	0	0	0	0	
1200	1284	0	0	0	1	6	33	212	620	328	66	11	5	2	0	0	0	0	0	0	0	0	0	0	0	0	0	0	
1300	1307	0	0	0	0	9	37	188	613	362	88	5	2	3	0	0	0	0	0	0	0	0	0	0	0	0	0	0	
1400	1450	0	0	0	1	3	21	197	694	419	91	18	6	0	0	0	0	0	0	0	0	0	0	0	0	0	0	0	
1500	1487	0	0	0	2	1	20	272	667	418	88	15	2	2	0	0	0	0	0	0	0	0	0	0	0	0	0	0	
1600	1783	0	0	2	4	14	69	323	803	430	107	25	4	2	0	0	0	0	0	0	0	0	0	0	0	0	0	0	
1700	1875	0	3	7	23	62	95	336	762	451	104	19	10	1	0	0	0	0	0	0	0	0	0	0	0	0	2	0	0
1800	1525	2	74	255	157	69	74	214	373	233	51	15	5	0	0	2	0	0	0	1	0	0	0	0	0	0	0	0	
1900	1037	0	0	0	5	0	14	197	502	228	70	17	2	0	1	1	0	0	0	0	0	0	0	0	0	0	0	0	
2000	756	0	0	2	0	2	2	108	335	217	65	17	8	0	0	0	0	0	0	0	0	0	0	0	0	0	0	0	
2100	475	0	0	0	1	3	7	56	189	132	50	27	7	2	1	0	0	0	0	0	0	0	0	0	0	0	0	0	
2200	261	0	0	0	0	0	1	25	72	87	46	15	9	1	3	2	0	0	0	0	0	0	0	0	0	0	0	0	
2300	164	0	0	1	0	0	0	9	52	43	33	13	8	4	0	1	0	0	0	0	0	0	0	0	0	0	0	0	
07-19	17839	2	79	273	200	204	484	2978	7868	4444	1021	214	50	15	1	3	0	0	0	1	0	0	0	0	0	0	2	0	0
06-22	20962	2	79	275	210	211	514	3410	9210	5283	1344	307	81	25	3	5	0	0	0	1	0	0	0	0	0	0	2	0	0
06-00	21387	2	79	276	210	211	515	3444	9334	5413	1423	335	98	30	6	8	0	0	0	1	0	0	0	0	0	0	2	0	0
00-00	21920	2	79	276	211	211	516	3465	9419	5572	1536	410	138	58	13	11	0	0	0	1	0	0	0	0	0	0	2	0	0

Site 2
 Location Oxford Road, Att - L/C, OSGR: SP 46884 37469
 Direction Two way

8643 / Bodicote Business Park, Banbury
 September 2018
 Automatic Traffic Count

27 September 2018

Time	Total	Speed Bins (mph)																										
		0 - 5	5 - 10	10 - 15	15 - 20	20 - 25	25 - 30	30 - 35	35 - 40	40 - 45	45 - 50	50 - 55	55 - 60	60 - 65	65 - 70	70 - 75	75 - 80	80 - 85	85 - 90	90 - 95	95 - 100	100 - 105	105 - 110	110 - 115	115 - 120	120 - 125	125 - 130	130 - 135
0000	69	0	0	0	0	0	0	1	13	19	14	6	10	4	1	1	0	0	0	0	0	0	0	0	0	0	0	0
0100	39	0	0	0	0	0	0	2	5	10	10	4	5	1	2	0	0	0	0	0	0	0	0	0	0	0	0	0
0200	61	0	0	0	0	0	1	1	6	18	20	8	5	2	0	0	0	0	0	0	0	0	0	0	0	0	0	0
0300	56	0	0	0	0	0	2	2	8	8	12	11	9	4	0	0	0	0	0	0	0	0	0	0	0	0	0	0
0400	61	0	0	0	0	0	0	1	11	17	17	8	3	3	0	0	1	0	0	0	0	0	0	0	0	0	0	0
0500	276	0	0	1	0	0	0	15	68	92	48	35	7	4	5	1	0	0	0	0	0	0	0	0	0	0	0	0
0600	823	0	0	0	1	0	1	62	318	275	115	33	12	4	1	0	1	0	0	0	0	0	0	0	0	0	0	0
0700	1677	0	4	6	8	30	73	282	734	400	108	22	9	1	0	0	0	0	0	0	0	0	0	0	0	0	0	0
0800	1743	5	18	44	46	38	90	329	701	364	82	23	3	0	0	0	0	0	0	0	0	0	0	0	0	0	0	0
0900	1439	0	0	13	37	31	50	277	627	304	71	21	6	1	1	0	0	0	0	0	0	0	0	0	0	0	0	0
1000	1206	0	0	1	0	0	17	154	566	356	93	15	2	2	0	0	0	0	0	0	0	0	0	0	0	0	0	0
1100	1256	0	0	1	3	6	38	149	547	380	99	26	6	1	0	0	0	0	0	0	0	0	0	0	0	0	0	0
1200	1284	0	0	0	3	3	16	151	545	418	116	21	5	3	1	0	0	0	0	0	0	0	1	1	0	0	0	0
1300	1325	0	0	0	0	1	17	164	634	375	112	15	7	0	0	0	0	0	0	0	0	0	0	0	0	0	0	0
1400	1378	0	0	2	1	5	48	225	600	366	102	17	7	4	0	1	0	0	0	0	0	0	0	0	0	0	0	0
1500	1543	0	0	0	3	30	15	167	688	494	115	19	8	4	0	0	0	0	0	0	0	0	0	0	0	0	0	0
1600	1743	0	11	28	33	35	61	260	683	483	123	13	5	7	0	0	1	0	0	0	0	0	0	0	0	0	0	0
1700	1874	0	14	29	34	33	58	343	795	431	106	25	3	1	1	0	1	0	0	0	0	0	0	0	0	0	0	0
1800	1481	0	0	0	2	3	36	216	661	417	120	15	11	0	0	0	0	0	0	0	0	0	0	0	0	0	0	0
1900	1102	0	0	0	0	3	12	231	506	268	60	15	3	2	2	0	0	0	0	0	0	0	0	0	0	0	0	0
2000	674	0	0	1	0	0	5	101	298	193	59	13	4	0	0	0	0	0	0	0	0	0	0	0	0	0	0	0
2100	455	0	0	0	0	0	7	48	168	150	52	26	2	1	0	1	0	0	0	0	0	0	0	0	0	0	0	0
2200	303	0	0	0	0	0	0	23	131	79	42	18	5	1	4	0	0	0	0	0	0	0	0	0	0	0	0	0
2300	134	0	0	1	0	0	0	9	32	44	33	8	5	1	1	0	0	0	0	0	0	0	0	0	0	0	0	0
07-19	17949	5	47	124	170	215	519	2717	7781	4788	1247	232	72	24	3	1	2	0	0	0	0	1	1	0	0	0	0	0
06-22	21003	5	47	125	171	218	544	3159	9071	5674	1533	319	93	31	6	2	3	0	0	0	0	1	1	0	0	0	0	0
06-00	21440	5	47	126	171	218	544	3191	9234	5797	1608	345	103	33	11	2	3	0	0	0	0	1	1	0	0	0	0	0
00-00	22002	5	47	127	171	218	547	3213	9345	5961	1729	417	142	51	19	4	4	0	0	0	0	1	1	0	0	0	0	0



Site 2
 Location Oxford Road, Att - L/C, OSGR: SP 46884 37469
 Direction Two way

8643 / Bodicote Business Park, Banbury
 September 2018
 Automatic Traffic Count

28 September 2018

Time	Total	Speed Bins (mph)																											
		0 - 5	5 - 10	10 - 15	15 - 20	20 - 25	25 - 30	30 - 35	35 - 40	40 - 45	45 - 50	50 - 55	55 - 60	60 - 65	65 - 70	70 - 75	75 - 80	80 - 85	85 - 90	90 - 95	95 - 100	100 - 105	105 - 110	110 - 115	115 - 120	120 - 125	125 - 130	130 - 135	135 - 140
0000	83	0	0	0	1	0	2	3	17	17	32	7	2	2	0	0	0	0	0	0	0	0	0	0	0	0	0	0	0
0100	62	0	0	0	0	0	0	4	11	13	15	10	5	3	1	0	0	0	0	0	0	0	0	0	0	0	0	0	0
0200	66	0	0	0	0	0	0	2	14	26	14	7	1	2	0	0	0	0	0	0	0	0	0	0	0	0	0	0	0
0300	55	0	0	0	0	0	0	4	4	13	13	11	5	4	1	0	0	0	0	0	0	0	0	0	0	0	0	0	0
0400	61	0	0	0	0	0	0	2	15	10	12	10	9	3	0	0	0	0	0	0	0	0	0	0	0	0	0	0	0
0500	293	0	0	0	0	1	4	27	85	87	46	27	9	6	1	0	0	0	0	0	0	0	0	0	0	0	0	0	0
0600	775	0	0	0	1	0	1	62	285	259	117	39	6	3	2	0	0	0	0	0	0	0	0	0	0	0	0	0	0
0700	1517	0	0	1	3	3	19	274	692	384	107	20	8	3	2	0	1	0	0	0	0	0	0	0	0	0	0	0	0
0800	1711	0	4	10	20	36	50	341	712	442	74	14	5	0	0	1	1	1	0	0	0	0	0	0	0	0	0	0	0
0900	1367	0	12	24	63	59	75	244	531	262	74	18	5	0	0	0	0	0	0	0	0	0	0	0	0	0	0	0	0
1000	1347	0	0	0	5	3	28	232	638	344	79	14	3	0	1	0	0	0	0	0	0	0	0	0	0	0	0	0	0
1100	1358	0	0	3	3	24	46	254	634	299	76	17	1	1	0	0	0	0	0	0	0	0	0	0	0	0	0	0	0
1200	1474	0	1	9	4	8	41	273	673	370	71	17	4	3	0	0	0	0	0	0	0	0	0	0	0	0	0	0	0
1300	1462	0	0	0	1	3	36	256	702	353	90	12	7	2	0	0	0	0	0	0	0	0	0	0	0	0	0	0	0
1400	1564	0	0	0	1	5	28	231	763	416	85	29	3	0	3	0	0	0	0	0	0	0	0	0	0	0	0	0	0
1500	1697	0	28	66	35	26	95	335	668	335	85	14	4	3	2	0	0	0	0	0	0	0	0	0	1	0	0	0	0
1600	1936	0	9	26	30	36	74	315	847	486	94	12	7	0	0	0	0	0	0	0	0	0	0	0	0	0	0	0	0
1700	1846	0	4	5	28	37	63	244	766	542	126	20	3	4	3	1	0	0	0	0	0	0	0	0	0	0	0	0	0
1800	1547	1	16	40	24	9	50	247	641	379	106	26	7	0	0	1	0	0	0	0	0	0	0	0	0	0	0	0	0
1900	1021	0	0	0	0	0	8	170	492	245	72	25	7	1	1	0	0	0	0	0	0	0	0	0	0	0	0	0	0
2000	679	0	0	0	0	0	7	73	258	223	84	24	6	2	0	1	0	1	0	0	0	0	0	0	0	0	0	0	0
2100	424	0	0	0	0	0	1	29	173	129	62	15	8	1	2	2	0	0	2	0	0	0	0	0	0	0	0	0	0
2200	310	0	0	0	0	0	2	13	91	103	60	24	9	3	2	0	2	1	0	0	0	0	0	0	0	0	0	0	0
2300	203	0	0	0	0	0	0	10	47	73	41	19	8	2	2	1	0	0	0	0	0	0	0	0	0	0	0	0	0
07-19	18826	1	74	184	217	249	605	3246	8267	4612	1067	213	57	16	11	3	2	1	0	0	0	0	0	0	1	0	0	0	0
06-22	21725	1	74	184	218	249	622	3580	9475	5468	1402	316	84	23	16	6	2	2	2	0	0	0	0	1	0	0	0	0	0
06-00	22238	1	74	184	218	249	624	3603	9613	5644	1503	359	101	28	20	7	4	3	2	0	0	0	0	1	0	0	0	0	0
00-00	22858	1	74	184	219	250	630	3645	9759	5810	1635	431	132	48	23	7	4	3	2	0	0	0	0	1	0	0	0	0	0



Site 2
 Location Oxford Road, Att - L/C, OSGR: SP 46884 37469
 Direction Two way

8643 / Bodicote Business Park, Banbury
 September 2018
 Automatic Traffic Count

29 September 2018

Time	Total	Speed Bins (mph)																											
		0 - 5	5 - 10	10 - 15	15 - 20	20 - 25	25 - 30	30 - 35	35 - 40	40 - 45	45 - 50	50 - 55	55 - 60	60 - 65	65 - 70	70 - 75	75 - 80	80 - 85	85 - 90	90 - 95	95 - 100	100 - 105	105 - 110	110 - 115	115 - 120	120 - 125	125 - 130	130 - 135	135 - 140
0000	125	0	0	0	0	0	1	4	29	43	19	21	5	1	1	0	0	1	0	0	0	0	0	0	0	0	0	0	0
0100	84	0	0	0	0	0	1	2	15	16	20	18	6	2	2	1	1	0	0	0	0	0	0	0	0	0	0	0	0
0200	72	0	0	0	0	0	0	3	17	19	11	10	6	5	1	0	0	0	0	0	0	0	0	0	0	0	0	0	0
0300	56	0	0	0	0	0	0	1	10	14	15	7	8	1	0	0	0	0	0	0	0	0	0	0	0	0	0	0	0
0400	58	0	0	0	0	0	0	2	10	13	13	7	7	4	1	0	0	1	0	0	0	0	0	0	0	0	0	0	0
0500	134	0	0	0	0	0	1	3	23	37	27	17	18	4	3	1	0	0	0	0	0	0	0	0	0	0	0	0	0
0600	233	0	0	0	0	0	0	11	57	82	48	19	10	4	2	0	0	0	0	0	0	0	0	0	0	0	0	0	0
0700	497	0	0	0	1	0	2	29	152	164	90	34	8	10	4	2	0	0	1	0	0	0	0	0	0	0	0	0	0
0800	875	0	0	0	1	3	17	53	329	343	93	25	9	0	2	0	0	0	0	0	0	0	0	0	0	0	0	0	0
0900	1205	0	0	1	3	5	25	165	546	342	92	19	4	1	0	1	0	0	1	0	0	0	0	0	0	0	0	0	0
1000	1349	0	0	2	22	25	31	185	600	358	96	22	5	1	2	0	0	0	0	0	0	0	0	0	0	0	0	0	0
1100	1399	0	2	1	4	10	17	234	644	367	93	17	8	2	0	0	0	0	0	0	0	0	0	0	0	0	0	0	0
1200	1527	0	15	41	28	30	54	229	591	376	128	31	2	2	0	0	0	0	0	0	0	0	0	0	0	0	0	0	0
1300	1474	0	0	0	3	14	34	249	662	370	110	24	5	3	0	0	0	0	0	0	0	0	0	0	0	0	0	0	0
1400	1354	0	0	0	5	1	22	198	651	356	89	23	4	2	3	0	0	0	0	0	0	0	0	0	0	0	0	0	0
1500	1316	0	0	5	8	13	12	170	614	362	100	24	6	2	0	0	0	0	0	0	0	0	0	0	0	0	0	0	0
1600	1293	0	0	1	4	13	9	124	552	431	115	30	14	0	0	0	0	0	0	0	0	0	0	0	0	0	0	0	0
1700	1267	0	0	0	2	3	1	116	570	416	121	28	8	1	1	0	0	0	0	0	0	0	0	0	0	0	0	0	0
1800	981	0	0	0	1	7	14	85	377	354	110	23	8	1	0	1	0	0	0	0	0	0	0	0	0	0	0	0	0
1900	742	0	0	0	0	0	6	60	329	239	81	18	9	0	0	0	0	0	0	0	0	0	0	0	0	0	0	0	0
2000	468	0	0	0	1	0	10	49	185	144	57	15	4	2	0	0	1	0	0	0	0	0	0	0	0	0	0	0	0
2100	399	0	0	0	0	0	3	40	149	117	61	19	6	2	0	1	0	1	0	0	0	0	0	0	0	0	0	0	0
2200	316	0	0	0	0	0	0	15	106	111	58	20	2	2	1	1	0	0	0	0	0	0	0	0	0	0	0	0	0
2300	241	0	0	0	0	0	1	13	71	76	46	21	11	0	1	1	0	0	0	0	0	0	0	0	0	0	0	0	0
07-19	14537	0	17	51	82	124	238	1837	6288	4239	1237	300	81	25	12	4	0	0	2	0	0	0	0	0	0	0	0	0	0
06-22	16379	0	17	51	83	124	257	1997	7008	4821	1484	371	110	33	14	5	1	1	2	0	0	0	0	0	0	0	0	0	0
06-00	16936	0	17	51	83	124	258	2025	7185	5008	1588	412	123	35	16	7	1	1	2	0	0	0	0	0	0	0	0	0	0
00-00	17465	0	17	51	83	124	261	2040	7289	5150	1693	492	173	52	24	9	2	3	2	0	0	0	0	0	0	0	0	0	0



Site 2
 Location Oxford Road, Att - L/C, OSGR: SP 46884 37469
 Direction Two way

8643 / Bodicote Business Park, Banbury
 September 2018
 Automatic Traffic Count

30 September 2018

Time	Total	Speed Bins (mph)																												
		0 - 5	5 - 10	10 - 15	15 - 20	20 - 25	25 - 30	30 - 35	35 - 40	40 - 45	45 - 50	50 - 55	55 - 60	60 - 65	65 - 70	70 - 75	75 - 80	80 - 85	85 - 90	90 - 95	95 - 100	100 - 105	105 - 110	110 - 115	115 - 120	120 - 125	125 - 130	130 - 135	135 - 140	
0000	143	0	0	0	0	0	0	12	36	25	35	23	8	4	0	0	0	0	0	0	0	0	0	0	0	0	0	0	0	
0100	118	0	0	0	0	2	1	6	25	28	22	19	10	2	2	1	0	0	0	0	0	0	0	0	0	0	0	0	0	
0200	88	0	0	0	0	0	1	1	17	22	19	15	6	6	1	0	0	0	0	0	0	0	0	0	0	0	0	0	0	
0300	60	0	0	0	0	0	0	1	8	10	15	12	7	6	0	1	0	0	0	0	0	0	0	0	0	0	0	0	0	
0400	63	0	0	0	1	0	0	0	11	12	14	12	4	5	1	1	2	0	0	0	0	0	0	0	0	0	0	0	0	
0500	73	0	0	0	0	0	1	6	11	24	14	7	3	2	2	3	0	0	0	0	0	0	0	0	0	0	0	0	0	
0600	158	0	0	0	0	0	0	9	32	60	29	18	6	3	1	0	0	0	0	0	0	0	0	0	0	0	0	0	0	
0700	293	0	0	0	2	0	0	12	67	106	60	26	13	4	2	1	0	0	0	0	0	0	0	0	0	0	0	0	0	
0800	529	0	0	1	0	5	2	23	155	204	103	22	9	3	0	1	1	0	0	0	0	0	0	0	0	0	0	0	0	
0900	814	0	0	1	1	5	13	98	305	267	87	28	5	1	3	0	0	0	0	0	0	0	0	0	0	0	0	0	0	
1000	1191	0	0	1	3	6	16	188	528	347	77	19	3	1	2	0	0	0	0	0	0	0	0	0	0	0	0	0	0	
1100	1242	0	0	3	4	6	24	218	555	338	79	10	4	0	1	0	0	0	0	0	0	0	0	0	0	0	0	0	0	
1200	1444	0	0	0	16	27	53	262	620	366	78	15	3	1	2	0	0	0	1	0	0	0	0	0	0	0	0	0	0	0
1300	1328	0	0	2	1	5	27	209	621	348	90	14	7	1	1	1	0	1	0	0	0	0	0	0	0	0	0	0	0	
1400	1207	0	0	0	5	3	30	151	526	361	97	24	4	4	0	0	1	1	0	0	0	0	0	0	0	0	0	0	0	
1500	1182	0	0	1	2	1	22	196	507	335	85	24	6	1	1	1	0	0	0	0	0	0	0	0	0	0	0	0	0	
1600	1071	0	0	1	3	1	10	138	398	393	93	23	10	0	1	0	0	0	0	0	0	0	0	0	0	0	0	0	0	
1700	892	0	0	0	0	0	8	88	316	319	112	35	11	2	1	0	0	0	0	0	0	0	0	0	0	0	0	0	0	
1800	742	0	0	0	0	0	5	60	269	261	106	28	9	2	2	0	0	0	0	0	0	0	0	0	0	0	0	0	0	
1900	577	0	0	0	0	0	0	43	235	186	78	24	6	4	0	0	1	0	0	0	0	0	0	0	0	0	0	0	0	
2000	389	0	0	0	0	0	2	24	146	116	63	27	7	3	0	1	0	0	0	0	0	0	0	0	0	0	0	0	0	
2100	286	0	0	0	0	0	1	29	99	82	47	19	3	4	1	0	0	1	0	0	0	0	0	0	0	0	0	0	0	
2200	167	0	0	0	0	0	5	15	49	36	38	12	7	2	3	0	0	0	0	0	0	0	0	0	0	0	0	0	0	
2300	99	0	0	0	0	0	1	9	32	22	16	12	4	2	1	0	0	0	0	0	0	0	0	0	0	0	0	0	0	
07-19	11935	0	0	10	37	59	210	1643	4867	3645	1067	268	84	20	16	4	2	2	1	0	0	0	0	0	0	0	0	0	0	
06-22	13345	0	0	10	37	59	213	1748	5379	4089	1284	356	106	34	18	5	3	3	1	0	0	0	0	0	0	0	0	0	0	
06-00	13611	0	0	10	37	59	219	1772	5460	4147	1338	380	117	38	22	5	3	3	1	0	0	0	0	0	0	0	0	0	0	
00-00	14156	0	0	10	38	61	222	1798	5568	4268	1457	468	155	63	28	11	5	3	1	0	0	0	0	0	0	0	0	0	0	

Site 2
 Location Oxford Road, Att - L/C, OSGR: SP 46884 37469
 Direction Two way

8643 / Bodicote Business Park, Banbury
 September 2018
 Automatic Traffic Count

01 October 2018

Time	Total	Speed Bins (mph)																										
		0 - 5	5 - 10	10 - 15	15 - 20	20 - 25	25 - 30	30 - 35	35 - 40	40 - 45	45 - 50	50 - 55	55 - 60	60 - 65	65 - 70	70 - 75	75 - 80	80 - 85	85 - 90	90 - 95	95 - 100	100 - 105	105 - 110	110 - 115	115 - 120	120 - 125	125 - 130	130 - 135
0000	38	0	0	0	0	0	0	7	5	9	8	4	4	0	1	0	0	0	0	0	0	0	0	0	0	0	0	0
0100	38	0	0	0	0	0	0	2	5	9	7	7	3	3	1	0	0	1	0	0	0	0	0	0	0	0	0	0
0200	48	0	0	0	0	0	0	5	11	9	10	7	2	1	1	1	1	0	0	0	0	0	0	0	0	0	0	0
0300	54	0	0	0	0	0	1	3	8	11	11	8	8	4	0	0	0	0	0	0	0	0	0	0	0	0	0	0
0400	75	0	0	0	0	0	0	6	11	18	10	13	11	2	4	0	0	0	0	0	0	0	0	0	0	0	0	0
0500	257	0	0	0	0	0	3	6	56	83	62	28	8	5	4	1	0	1	0	0	0	0	0	0	0	0	0	0
0600	777	0	0	0	1	0	2	74	296	253	119	21	3	7	0	0	1	0	0	0	0	0	0	0	0	0	0	0
0700	1656	12	30	37	42	60	85	293	645	353	81	8	8	0	1	1	0	0	0	0	0	0	0	0	0	0	0	0
0800	1698	1	78	118	67	75	53	193	685	341	77	7	3	0	0	0	0	0	0	0	0	0	0	0	0	0	0	0
0900	1290	0	1	5	7	6	43	279	575	283	69	13	5	2	0	1	1	0	0	0	0	0	0	0	0	0	0	0
1000	1216	0	0	0	2	4	26	197	567	339	60	16	3	1	1	0	0	0	0	0	0	0	0	0	0	0	0	0
1100	1189	0	0	0	3	15	24	194	554	322	59	13	4	0	1	0	0	0	0	0	0	0	0	0	0	0	0	0
1200	1186	0	0	0	0	6	29	171	491	375	81	26	5	0	1	1	0	0	0	0	0	0	0	0	0	0	0	0
1300	1281	0	0	0	0	3	23	230	552	375	77	16	3	1	1	0	0	0	0	0	0	0	0	0	0	0	0	0
1400	1320	0	0	1	6	2	25	203	668	305	82	21	3	1	3	0	0	0	0	0	0	0	0	0	0	0	0	0
1500	1446	0	0	1	3	4	38	277	605	402	97	15	3	0	0	1	0	0	0	0	0	0	0	0	0	0	0	0
1600	1708	0	0	0	1	2	30	278	782	490	102	18	2	2	0	1	0	0	0	0	0	0	0	0	0	0	0	0
1700	1861	0	4	21	62	76	88	376	756	369	87	17	4	0	1	0	0	0	0	0	0	0	0	0	0	0	0	0
1800	1423	0	0	0	5	14	60	256	617	363	87	19	1	0	1	0	0	0	0	0	0	0	0	0	0	0	0	0
1900	1001	0	0	0	1	2	11	152	490	278	55	5	5	2	0	0	0	0	0	0	0	0	0	0	0	0	0	0
2000	511	0	0	0	1	0	0	36	203	166	77	15	9	3	0	1	0	0	0	0	0	0	0	0	0	0	0	0
2100	372	0	0	0	0	5	8	28	150	118	35	20	7	1	0	0	0	0	0	0	0	0	0	0	0	0	0	0
2200	252	0	0	0	0	0	1	15	90	88	33	15	5	2	1	0	1	1	0	0	0	0	0	0	0	0	0	0
2300	105	0	0	0	0	0	0	4	30	37	12	14	6	1	0	1	0	0	0	0	0	0	0	0	0	0	0	0
07-19	17274	13	113	183	198	267	524	2947	7497	4317	959	189	44	7	10	5	1	0	0	0	0	0	0	0	0	0	0	0
06-22	19935	13	113	183	201	274	545	3237	8636	5132	1245	250	68	20	10	6	2	0	0	0	0	0	0	0	0	0	0	0
06-00	20292	13	113	183	201	274	546	3256	8756	5257	1290	279	79	23	11	7	3	1	0	0	0	0	0	0	0	0	0	0
00-00	20802	13	113	183	201	274	550	3285	8852	5396	1398	346	115	38	22	9	4	3	0	0	0	0	0	0	0	0	0	0

Site 2
 Location Oxford Road, Att - L/C, OSGR: SP 46884 37469
 Direction Two way

8643 / Bodicote Business Park, Banbury
 September 2018
 Automatic Traffic Count

02 October 2018

Time	Total	Speed Bins (mph)																										
		0 - 5	5 - 10	10 - 15	15 - 20	20 - 25	25 - 30	30 - 35	35 - 40	40 - 45	45 - 50	50 - 55	55 - 60	60 - 65	65 - 70	70 - 75	75 - 80	80 - 85	85 - 90	90 - 95	95 - 100	100 - 105	105 - 110	110 - 115	115 - 120	120 - 125	125 - 130	130 - 135
0000	57	0	0	0	0	0	0	3	18	15	10	7	2	1	1	0	0	0	0	0	0	0	0	0	0	0	0	0
0100	39	0	0	0	0	0	1	1	7	10	10	5	2	1	2	0	0	0	0	0	0	0	0	0	0	0	0	0
0200	50	0	0	0	0	0	0	3	10	11	10	8	4	2	0	1	1	0	0	0	0	0	0	0	0	0	0	0
0300	56	0	0	0	0	0	0	3	7	5	17	12	5	4	3	0	0	0	0	0	0	0	0	0	0	0	0	0
0400	66	0	0	0	0	0	0	2	11	21	10	10	10	2	0	0	0	0	0	0	0	0	0	0	0	0	0	0
0500	257	0	0	0	0	0	0	4	46	92	67	32	11	4	1	0	0	0	0	0	0	0	0	0	0	0	0	0
0600	811	0	0	1	4	10	2	47	316	287	99	32	11	1	1	0	0	0	0	0	0	0	0	0	0	0	0	0
0700	1706	2	26	46	11	9	94	325	722	379	68	19	4	1	0	0	0	0	0	0	0	0	0	0	0	0	0	0
0800	1782	4	39	37	66	64	160	284	718	319	68	18	3	2	0	0	0	0	0	0	0	0	0	0	0	0	0	0
0900	1297	0	0	2	2	30	40	163	558	398	78	20	5	1	0	0	0	0	0	0	0	0	0	0	0	0	0	0
1000	1223	0	0	0	0	7	17	220	569	323	69	12	6	0	0	0	0	0	0	0	0	0	0	0	0	0	0	0
1100	1219	0	0	0	4	11	50	235	576	276	50	13	3	1	0	0	0	0	0	0	0	0	0	0	0	0	0	0
1200	1249	0	0	0	0	0	33	238	551	322	82	20	3	0	0	0	0	0	0	0	0	0	0	0	0	0	0	0
1300	1246	0	0	0	1	11	33	194	577	326	78	17	6	3	0	0	0	0	0	0	0	0	0	0	0	0	0	0
1400	1336	0	0	2	0	0	24	193	623	372	92	22	5	2	1	0	0	0	0	0	0	0	0	0	0	0	0	0
1500	1475	0	0	1	2	7	67	234	666	372	101	18	5	0	1	1	0	0	0	0	0	0	0	0	0	0	0	0
1600	1698	0	1	2	10	22	57	269	725	482	104	20	5	0	1	0	0	0	0	0	0	0	0	0	0	0	0	0
1700	1941	0	10	40	43	41	97	424	677	451	129	19	6	3	0	0	0	1	0	0	0	0	0	0	0	0	0	0
1800	1506	0	0	0	2	17	41	271	706	364	80	20	3	0	1	0	0	1	0	0	0	0	0	0	0	0	0	0
1900	1020	0	0	1	4	7	20	199	439	267	63	16	2	2	0	0	0	0	0	0	0	0	0	0	0	0	0	0
2000	611	0	0	0	2	2	5	43	208	230	98	14	4	3	1	1	0	0	0	0	0	0	0	0	0	0	0	0
2100	433	0	0	1	1	0	0	44	156	147	44	22	10	3	2	1	1	0	0	0	1	0	0	0	0	0	0	0
2200	230	0	0	0	0	0	0	8	64	77	50	17	11	2	1	0	0	0	0	0	0	0	0	0	0	0	0	0
2300	132	0	0	0	0	1	0	10	49	33	14	18	3	2	1	0	1	0	0	0	0	0	0	0	0	0	0	0
07-19	17678	6	76	130	141	219	713	3050	7668	4384	999	218	54	13	4	1	0	2	0	0	0	0	0	0	0	0	0	0
06-22	20553	6	76	133	152	238	740	3383	8787	5315	1303	302	81	22	8	3	1	2	0	0	1	0	0	0	0	0	0	0
06-00	20915	6	76	133	152	239	740	3401	8900	5425	1367	337	95	26	10	3	2	2	0	0	1	0	0	0	0	0	0	0
00-00	21440	6	76	133	152	239	741	3417	8999	5579	1491	411	129	40	17	4	3	2	0	0	1	0	0	0	0	0	0	0

Site 2
 Location Oxford Road, Att - L/C, OSGR: SP 46884 37469
 Direction Two way

8643 / Bodicote Business Park, Banbury
 September 2018
 Automatic Traffic Count

Virtual Day (7)

Time	Total	Speed Bins (mph)																										
		0 - 5	5 - 10	10 - 15	15 - 20	20 - 25	25 - 30	30 - 35	35 - 40	40 - 45	45 - 50	50 - 55	55 - 60	60 - 65	65 - 70	70 - 75	75 - 80	80 - 85	85 - 90	90 - 95	95 - 100	100 - 105	105 - 110	110 - 115	115 - 120	120 - 125	125 - 130	130 - 135
0000	82	0	0	0	0	0	0	5	18	20	19	11	5	2	1	0	0	0	0	0	0	0	0	0	0	0	0	0
0100	61	0	0	0	0	0	0	3	11	15	13	10	5	2	1	0	0	0	0	0	0	0	0	0	0	0	0	0
0200	63	0	0	0	0	0	0	2	12	17	14	9	4	3	1	0	0	0	0	0	0	0	0	0	0	0	0	0
0300	57	0	0	0	0	0	0	2	8	11	14	10	7	4	1	0	0	0	0	0	0	0	0	0	0	0	0	0
0400	64	0	0	0	0	0	0	2	12	15	13	10	7	3	1	0	0	0	0	0	0	0	0	0	0	0	0	0
0500	220	0	0	0	0	0	1	10	47	72	45	25	10	6	2	1	0	0	0	0	0	0	0	0	0	0	0	0
0600	633	0	0	0	2	2	2	48	231	211	95	28	9	4	1	0	0	0	0	0	0	0	0	0	0	0	0	0
0700	1287	2	9	14	11	18	48	224	532	309	88	21	7	3	1	1	0	0	0	0	0	0	0	0	0	0	0	0
0800	1432	1	20	30	29	32	56	213	591	349	86	19	5	1	0	0	0	0	0	0	0	0	0	0	0	0	0	0
0900	1252	0	2	7	16	19	37	208	538	317	79	21	5	1	1	0	0	0	0	0	0	0	0	0	0	0	0	0
1000	1247	0	0	1	5	7	22	195	572	345	78	17	4	1	1	0	0	0	0	0	0	0	0	0	0	0	0	0
1100	1271	0	0	1	3	12	32	211	591	324	75	16	4	1	0	0	0	0	0	0	0	0	0	0	0	0	0	0
1200	1350	0	2	7	7	11	37	219	584	365	89	20	4	2	1	0	0	0	0	0	0	0	0	0	0	0	0	0
1300	1346	0	0	0	1	7	30	213	623	358	92	15	5	2	0	0	0	0	0	0	0	0	0	0	0	0	0	0
1400	1373	0	0	1	3	3	28	200	646	371	91	22	5	2	1	0	0	0	0	0	0	0	0	0	0	0	0	0
1500	1449	0	4	11	8	12	38	236	631	388	96	18	5	2	1	0	0	0	0	0	0	0	0	0	0	0	0	0
1600	1605	0	3	9	12	18	44	244	684	456	105	20	7	2	0	0	0	0	0	0	0	0	0	0	0	0	0	0
1700	1651	0	5	15	27	36	59	275	663	426	112	23	6	2	1	0	0	0	0	0	0	0	0	0	0	0	0	0
1800	1315	0	13	42	27	17	40	193	521	339	94	21	6	0	1	1	0	0	0	0	0	0	0	0	0	0	0	0
1900	929	0	0	0	1	2	10	150	428	244	68	17	5	2	1	0	0	0	0	0	0	0	0	0	0	0	0	0
2000	584	0	0	0	1	1	4	62	233	184	72	18	6	2	0	1	0	0	0	0	0	0	0	0	0	0	0	0
2100	406	0	0	0	0	1	4	39	155	125	50	21	6	2	1	1	0	0	0	0	0	0	0	0	0	0	0	0
2200	263	0	0	0	0	0	1	16	86	83	47	17	7	2	2	0	0	0	0	0	0	0	0	0	0	0	0	0
2300	154	0	0	0	0	0	0	9	45	47	28	15	6	2	1	1	0	0	0	0	0	0	0	0	0	0	0	0
07-19	16577	4	58	136	149	191	470	2631	7177	4347	1085	233	63	17	8	3	1	1	0	0	0	0	0	0	0	0	0	0
06-22	19129	4	58	137	153	196	491	2931	8224	5112	1371	317	89	27	11	5	2	1	1	0	0	0	0	0	0	0	0	0
06-00	19546	4	58	138	153	196	492	2956	8355	5242	1445	350	102	30	14	6	2	1	1	0	0	0	0	0	0	0	0	0
00-00	20092	4	58	138	154	197	495	2980	8462	5391	1563	425	141	50	21	8	3	2	1	0	0	0	0	0	0	0	0	0

Site 2
 Location Oxford Road, Att - L/C, OSGR: SP 46884 37469
 Direction Two way

8643 / Bodicote Business Park, Banbury
 September 2018
 Automatic Traffic Count







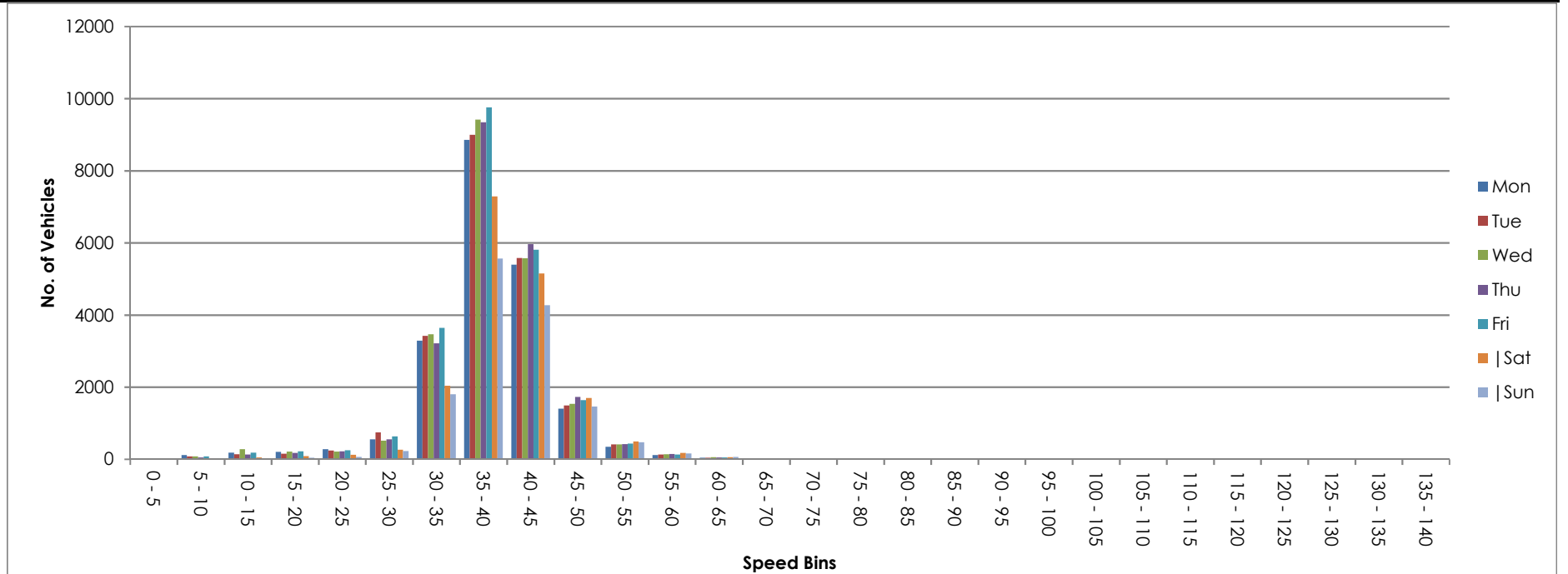



Virtual Week (1)

Time	Total	Speed Bins (mph)																												
		0 - 5	5 - 10	10 - 15	15 - 20	20 - 25	25 - 30	30 - 35	35 - 40	40 - 45	45 - 50	50 - 55	55 - 60	60 - 65	65 - 70	70 - 75	75 - 80	80 - 85	85 - 90	90 - 95	95 - 100	100 - 105	105 - 110	110 - 115	115 - 120	120 - 125	125 - 130	130 - 135	135 - 140	
Mon	20802	13	113	183	201	274	550	3285	8852	5396	1398	346	115	38	22	9	4	3	0	0	0	0	0	0	0	0	0	0	0	0
Tue	21440	6	76	133	152	239	741	3417	8999	5579	1491	411	129	40	17	4	3	2	0	0	1	0	0	0	0	0	0	0	0	
Wed	21920	2	79	276	211	211	516	3465	9419	5572	1536	410	138	58	13	11	0	0	0	1	0	0	0	0	0	0	2	0		
Thu	22002	5	47	127	171	218	547	3213	9345	5961	1729	417	142	51	19	4	4	0	0	0	0	1	1	0	0	0	0	0		
Fri	22858	1	74	184	219	250	630	3645	9759	5810	1635	431	132	48	23	7	4	3	2	0	0	0	0	1	0	0	0	0		
Sat	17465	0	17	51	83	124	261	2040	7289	5150	1693	492	173	52	24	9	2	3	2	0	0	0	0	0	0	0	0	0		
Sun	14156	0	0	10	38	61	222	1798	5568	4268	1457	468	155	63	28	11	5	3	1	0	0	0	0	0	0	0	0	0		
5 Day Ave.	21804	5	78	181	191	238	597	3405	9275	5664	1558	403	131	47	19	7	3	2	0	0	0	0	0	0	0	0	0	0		
7 Day Ave.	20092	4	58	138	154	197	495	2980	8462	5391	1563	425	141	50	21	8	3	2	1	0	0	0	0	0	0	0	0	0		
--	140643	27	406	964	1075	1377	3467	20863	59231	37736	10939	2975	984	350	146	55	22	14	5	1	1	1	1	1	0	0	2	0		

Summary Graphs



ATC VEHICLE CATEGORIES

Axles	Groups	Description	Class		Parameters	Dominant Vehicle	Aggregate
2	1 or 2	Very Short - Bicycle or Motorcycle	MC	1	$d(1) < 1.7m$ & axles=2		
2	1 or 2	Short - Sedan, Wagon, 4WD, Utility, Light Van	SV	2	$d(1) \geq 1.7m$, $d(1) \leq 3.2m$ & axles=2		
3, 4 or 5	3	Short Towing - Trailer, Caravan, Boat, etc.	SVT	3	groups=3, $d(1) \geq 2.1m$, $d(1) \leq 3.2m$, $d(2) \geq 2.1m$ & axles=3,4,5		1 (Light)
2	2	Two axle truck or Bus	TB2	4	$d(1) > 3.2m$ & axles=2		
3	2	Three axle truck or Bus	TB3	5	axles=3 & groups=2		
>3	2	Four axle truck	T4	6	axles>3 & groups=2		2 (Medium)
3	3	Three axle articulated vehicle or Rigid vehicle and trailer	ART3	7	$d(1) > 3.2m$, axles=3 & groups=3		
4	>2	Four axle articulated vehicle or Rigid vehicle and trailer	ART4	8	$d(2) < 2.1m$ or $d(1) < 2.1m$ or $d(1) > 3.2m$ axles = 4 & groups>2		
5	>2	Five axle articulated vehicle or Rigid vehicle and trailer	ART5	9	$d(2) < 2.1m$ or $d(1) < 2.1m$ or $d(1) > 3.2m$ axles=5 & groups>2		
>=6	>2	Six (or more) axle articulated vehicle or Rigid vehicle and trailer	ART6	10	axles=6 & groups>2 or axles>6 & groups=3		
>6	4	B-Double or Heavy truck and trailer	BD	11	groups=4 & axles>6		
>6	>=5	Double or triple road train or Heavy truck and two (or more) trailers	DRT	12	groups>=5 & axles>6		3 (Heavy)

ATC SPEED BINS & DATA HEADINGS

Heading	Description
0 - 5	Speed bin totals 0 - 5 mph
5 - 10	Speed bin totals 5 - 10 mph
10 - 15	Speed bin totals 10 - 15 mph
15 - 20	Speed bin totals 15 - 20 mph
20 - 25	Speed bin totals 20 - 25 mph
25 - 30	Speed bin totals 25 - 30 mph
30 - 35	Speed bin totals 30 - 35 mph
35 - 40	Speed bin totals 35 - 40 mph
40 - 45	Speed bin totals 40 - 45 mph
45 - 50	Speed bin totals 45 - 50 mph
50 - 55	Speed bin totals 50 - 55 mph
55 - 60	Speed bin totals 55 - 60 mph
60 - 65	Speed bin totals 60 - 65 mph
65 - 70	Speed bin totals 65 - 70 mph
70 - 75	Speed bin totals 70 - 75 mph
75 - 80	Speed bin totals 75 - 80 mph
80 - 85	Speed bin totals 80 - 85 mph
85 - 90	Speed bin totals 85 - 90 mph
90 - 95	Speed bin totals 90 - 95 mph
95 - 100	Speed bin totals 95 - 100 mph
100 - 105	Speed bin totals 100 - 105 mph
105 - 110	Speed bin totals 105 - 110 mph
110 - 115	Speed bin totals 110 - 115 mph
115 - 120	Speed bin totals 115 - 120 mph
120 - 125	Speed bin totals 120 - 125 mph
125 - 130	Speed bin totals 125 - 130 mph
130 - 135	Speed bin totals 130 - 135 mph
135 - 140	Speed bin totals 135 - 140 mph

Heading	Description
>PSL	Greater than the posted speed limit
>PSL%	Greater than the posted speed limit as a percentage
>SL1 ACPO	Greater than ACPO (Association of Chief Police Officers) standard. ACPO is PSL x 10%+2mph
>SL1% ACPO	Greater than ACPO displayed as a percentage
>SL2 DfT	Greater than DfT (Department For Transport) standard. DfT is PSL plus 15mph.
>SL2% DfT	Greater than DfT displayed as a percentage
Mean	Average speed
Vpp 85	85th percentile speed

Appendix F – Personal Injury Accident Data



Accidents between dates 01/01/2013 and 31/08/2018 (68) months

Selection: Notes:

Selected using Manual Selection

Monday 21/10/2013 Time 1502 Slight at A4260 OXFORD RD J/W WEEPING CROSS RD BANBURY

E: 446702 N: 237779 Junction Detail: T or staggered junct Control: Give way or controlled

Raining without high winds Road surface Wet/Damp Daylight

Vehicle Reference 1 Car Moving from W to SE Turning right On main carriageway

Vehicle Reference 2 Car Moving from SE to N Going ahead other On main carriageway

Casualty Reference: 1 Age: 34 Male Driver/rider Severity: Slight Injured by vehicle: 2

Thursday 05/02/2015 Time 0552 Serious at A4260 OXFORD RD APPROX 160M SE OF J/W WEEPING CROSS RD BANBURY - UNCERTAINTY
ABOUT EXACT LOCATION

E: 446772 N: 237637 Junction Detail: Using private drive c Control: Give way or controlled

Fine without high winds Road surface Wet/Damp Darkness: street lights present and lit

Vehicle Reference 1 Van or Goods 3.5 to Moving from SE to N Going ahead other On main carriageway

Vehicle Reference 2 Taxi/Private hire car Moving from N to SE Going ahead other On main carriageway

Casualty Reference: 1 Age: 21 Female Driver/rider Severity: Serious Injured by vehicle: 2

Accidents between dates 01/01/2013 and 31/08/2018 (68) months

Selection: Notes:

Selected using Manual Selection

Thursday 17/08/2017 Time 1700 Slight at A4260 OXFORD ROAD APPROX 125M SE OF J/W WEEPING CROSS BODICOTE

E: 446761 N: 237656 Junction Detail: Not within 20m of j Control:

Fine without high winds Road surface Dry Daylight

Vehicle Reference 1 Car Moving from SE to N Going ahead other On main carriageway

Vehicle Reference 2 Car Moving from SE to N Stopping On main carriageway

Casualty Reference: 1 Age: 27 Female Driver/rider Severity: Slight Injured by vehicle: 2

Tuesday 30/01/2018 Time 1424 Slight at A4260 OXFORD RD APPROX 550 M SE OF J/W WEEPING CROSS RD BODICOTE

E: 447004 N: 237326 Junction Detail: Not within 20m of j Control:

Fine without high winds Road surface Dry Daylight

Vehicle Reference 1 Car Moving from S to N Going ahead left bend On main carriageway

Casualty Reference: 1 Age: 63 Female Driver/rider Severity: Slight Injured by vehicle: 1

Accidents between dates 01/01/2013 and 31/08/2018 (68) months

Selection: Notes:

Selected using Manual Selection

Accidents involving:

	Fatal	Serious	Slight	Total
Motor vehicles only (excluding 2-wheels)	0	1	3	4
2-wheeled motor vehicles	0	0	0	0
Pedal cycles	0	0	0	0
Horses & other	0	0	0	0
Total	0	1	3	4

Casualties:

	Fatal	Serious	Slight	Total
Vehicle driver	0	1	3	4
Passenger	0	0	0	0
Motorcycle rider	0	0	0	0
Cyclist	0	0	0	0
Pedestrian	0	0	0	0
Other	0	0	0	0
Total	0	1	3	4

Number of casualties meeting the criteria: 4

Appendix G – TRICS Output Reports

Calculation Reference: AUDIT-515501-190115-0105

TRIP RATE CALCULATION SELECTION PARAMETERS:

Land Use : 01 - RETAIL
 Category : A - FOOD SUPERSTORE
 MULTI-MODAL VEHICLES

Selected regions and areas:

03	SOUTH WEST	
	DC DORSET	1 days
09	NORTH	
	CB CUMBRIA	1 days
17	ULSTER (NORTHERN IRELAND)	
	AR ARMAGH	1 days

This section displays the number of survey days per TRICS® sub-region in the selected set

Secondary Filtering selection:

This data displays the chosen trip rate parameter and its selected range. Only sites that fall within the parameter range are included in the trip rate calculation.

Parameter: Gross floor area
 Actual Range: 1487 to 2416 (units: sqm)
 Range Selected by User: 800 to 4000 (units: sqm)

Parking Spaces Range: Selected: 0 to 833 Actual: 0 to 833

Public Transport Provision:

Selection by: Include all surveys

Date Range: 01/01/00 to 19/07/13

This data displays the range of survey dates selected. Only surveys that were conducted within this date range are included in the trip rate calculation.

Selected survey days:

Friday 3 days

This data displays the number of selected surveys by day of the week.

Selected survey types:

Manual count 3 days
 Directional ATC Count 0 days

This data displays the number of manual classified surveys and the number of unclassified ATC surveys, the total adding up to the overall number of surveys in the selected set. Manual surveys are undertaken using staff, whilst ATC surveys are undertaken using machines.

Selected Locations:

Suburban Area (PPS6 Out of Centre) 1
 Edge of Town 2

This data displays the number of surveys per main location category within the selected set. The main location categories consist of Free Standing, Edge of Town, Suburban Area, Neighbourhood Centre, Edge of Town Centre, Town Centre and Not Known.

Selected Location Sub Categories:

Residential Zone 2
 No Sub Category 1

This data displays the number of surveys per location sub-category within the selected set. The location sub-categories consist of Commercial Zone, Industrial Zone, Development Zone, Residential Zone, Retail Zone, Built-Up Zone, Village, Out of Town, High Street and No Sub Category.

Secondary Filtering selection:

Use Class:

A1 3 days

This data displays the number of surveys per Use Class classification within the selected set. The Use Classes Order 2005 has been used for this purpose, which can be found within the Library module of TRICS®.

Secondary Filtering selection (Cont.):

Population within 1 mile:

1,001 to 5,000	1 days
10,001 to 15,000	1 days
50,001 to 100,000	1 days

This data displays the number of selected surveys within stated 1-mile radii of population.

Population within 5 miles:

5,001 to 25,000	1 days
25,001 to 50,000	1 days
250,001 to 500,000	1 days

This data displays the number of selected surveys within stated 5-mile radii of population.

Car ownership within 5 miles:

0.5 or Less	1 days
0.6 to 1.0	2 days

This data displays the number of selected surveys within stated ranges of average cars owned per residential dwelling, within a radius of 5-miles of selected survey sites.

Petrol filling station:

PFS is present at the site and is included in the count	0 days
PFS is present at the site but is excluded from the count	0 days
There is no PFS at the site	3 days

This data displays the number of surveys within the selected set that include petrol filling station activity, and the number of surveys that do not.

Travel Plan:

Not Known	1 days
No	2 days

This data displays the number of surveys within the selected set that were undertaken at sites with Travel Plans in place, and the number of surveys that were undertaken at sites without Travel Plans.

PTAL Rating:

No PTAL Present	3 days
-----------------	--------

This data displays the number of selected surveys with PTAL Ratings.

LIST OF SITES relevant to selection parameters

1	AR-01-A-01 BEECH VALLEY DUNGANNON	TESCO		ARMAGH
	Edge of Town Residential Zone			
	Total Gross floor area:		2416 sqm	
	Survey date: FRIDAY		15/11/02	Survey Type: MANUAL
2	CB-01-A-07 WIGTON ROAD CARLISLE NEWTOWN	SOMERFIELD		CUMBRIA
	Suburban Area (PPS6 Out of Centre) Residential Zone			
	Total Gross floor area:		1700 sqm	
	Survey date: FRIDAY		05/02/10	Survey Type: MANUAL
3	DC-01-A-13 SEA ROAD NORTH BRIDPORT ST ANDREWS WELL	CO-OP PIONEER		DORSET
	Edge of Town No Sub Category			
	Total Gross floor area:		1487 sqm	
	Survey date: FRIDAY		07/07/00	Survey Type: MANUAL

This section provides a list of all survey sites and days in the selected set. For each individual survey site, it displays a unique site reference code and site address, the selected trip rate calculation parameter and its value, the day of the week and date of each survey, and whether the survey was a manual classified count or an ATC count.

TRIP RATE for Land Use 01 - RETAIL/A - FOOD SUPERSTORE

MULTI-MODAL VEHICLES

Calculation factor: 100 sqm

BOLD print indicates peak (busiest) period

Time Range	ARRIVALS			DEPARTURES			TOTALS		
	No. Days	Ave. GFA	Trip Rate	No. Days	Ave. GFA	Trip Rate	No. Days	Ave. GFA	Trip Rate
00:00 - 01:00									
01:00 - 02:00									
02:00 - 03:00									
03:00 - 04:00									
04:00 - 05:00									
05:00 - 06:00									
06:00 - 07:00									
07:00 - 08:00	3	1868	0.875	3	1868	0.464	3	1868	1.339
08:00 - 09:00	3	1868	3.980	3	1868	2.856	3	1868	6.836
09:00 - 10:00	3	1868	4.765	3	1868	3.677	3	1868	8.442
10:00 - 11:00	3	1868	5.729	3	1868	4.855	3	1868	10.584
11:00 - 12:00	3	1868	6.978	3	1868	6.711	3	1868	13.689
12:00 - 13:00	3	1868	6.853	3	1868	6.711	3	1868	13.564
13:00 - 14:00	3	1868	6.372	3	1868	6.657	3	1868	13.029
14:00 - 15:00	3	1868	6.711	3	1868	6.443	3	1868	13.154
15:00 - 16:00	3	1868	6.604	3	1868	7.157	3	1868	13.761
16:00 - 17:00	3	1868	8.495	3	1868	7.906	3	1868	16.401
17:00 - 18:00	3	1868	9.459	3	1868	9.727	3	1868	19.186
18:00 - 19:00	3	1868	6.925	3	1868	8.228	3	1868	15.153
19:00 - 20:00	3	1868	5.568	3	1868	6.389	3	1868	11.957
20:00 - 21:00	3	1868	4.319	3	1868	4.908	3	1868	9.227
21:00 - 22:00	3	1868	2.766	3	1868	3.677	3	1868	6.443
22:00 - 23:00	1	1487	0.000	1	1487	0.605	1	1487	0.605
23:00 - 24:00									
Total Rates:			86.399			86.971			173.370

This section displays the trip rate results based on the selected set of surveys and the selected count type (shown just above the table). It is split by three main columns, representing arrivals trips, departures trips, and total trips (arrivals plus departures). Within each of these main columns are three sub-columns. These display the number of survey days where count data is included (per time period), the average value of the selected trip rate calculation parameter (per time period), and the trip rate result (per time period). Total trip rates (the sum of the column) are also displayed at the foot of the table.

To obtain a trip rate, the average (mean) trip rate parameter value (TRP) is first calculated for all selected survey days that have count data available for the stated time period. The average (mean) number of arrivals, departures or totals (whichever applies) is also calculated (COUNT) for all selected survey days that have count data available for the stated time period. Then, the average count is divided by the average trip rate parameter value, and multiplied by the stated calculation factor (shown just above the table and abbreviated here as FACT). So, the method is: $COUNT/TRP*FACT$. Trip rates are then rounded to 3 decimal places.

The survey data, graphs and all associated supporting information, contained within the TRICS Database are published by TRICS Consortium Limited ("the Company") and the Company claims copyright and database rights in this published work. The Company authorises those who possess a current TRICS licence to access the TRICS Database and copy the data contained within the TRICS Database for the licence holders' use only. Any resulting copy must retain all copyrights and other proprietary notices, and any disclaimer contained thereon.

The Company accepts no responsibility for loss which may arise from reliance on data contained in the TRICS Database. [No warranty of any kind, express or implied, is made as to the data contained in the TRICS Database.]

Parameter summary

Trip rate parameter range selected:	1487 - 2416 (units: sqm)
Survey date date range:	01/01/00 - 19/07/13
Number of weekdays (Monday-Friday):	3
Number of Saturdays:	0
Number of Sundays:	0
Surveys automatically removed from selection:	0
Surveys manually removed from selection:	0

This section displays a quick summary of some of the data filtering selections made by the TRICS® user. The trip rate calculation parameter range of all selected surveys is displayed first, followed by the range of minimum and maximum survey dates selected by the user. Then, the total number of selected weekdays and weekend days in the selected set of surveys are shown. Finally, the number of survey days that have been manually removed from the selected set outside of the standard filtering procedure are displayed.

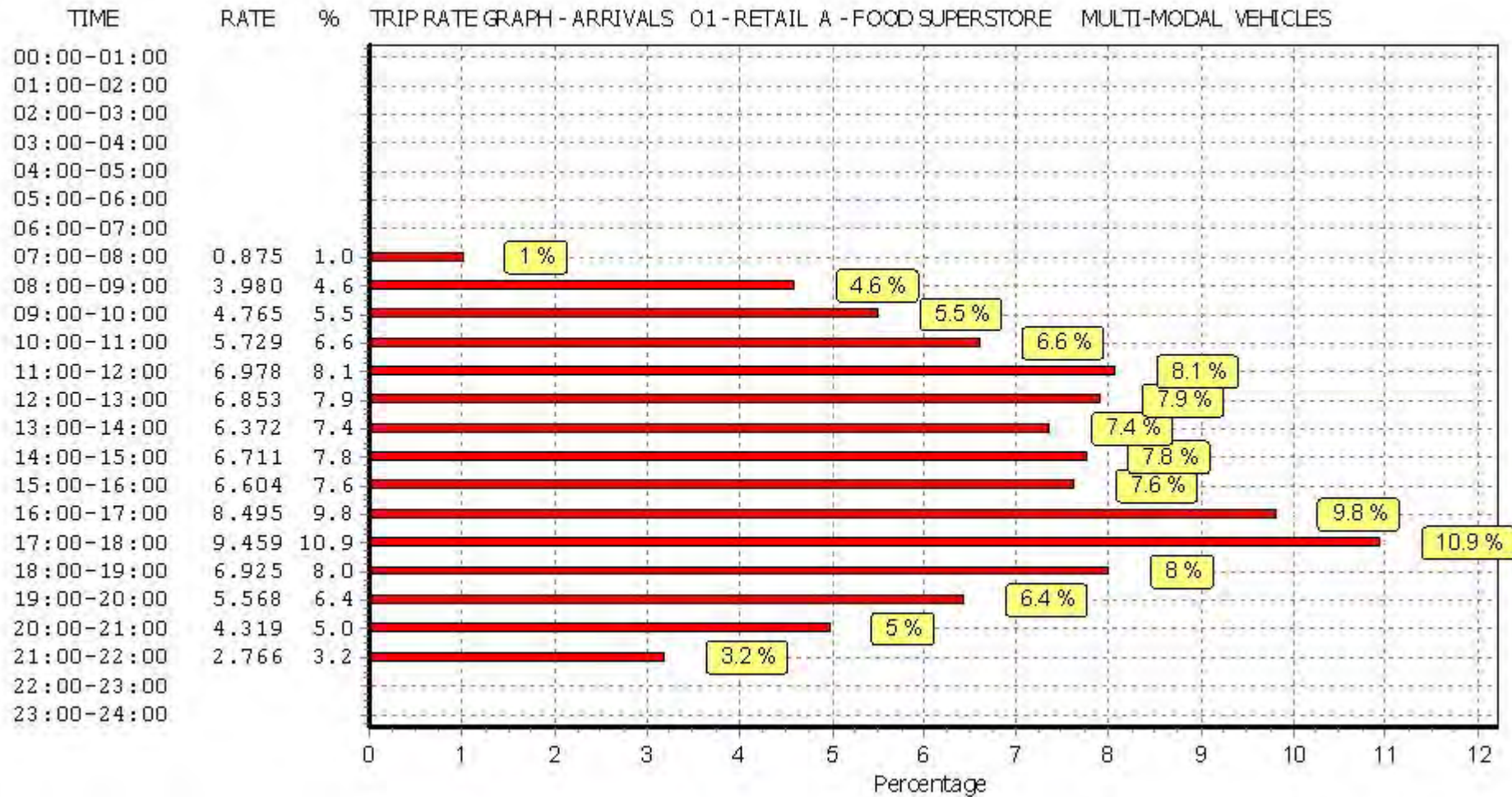

This graph is a visual representation of the trip rate calculation results screen. The same time periods and trip rates are displayed, but in addition there is an additional column showing the percentage of the total trip rate by individual time period, allowing peak periods to be easily identified through observation. Note that the type of count and the selected direction is shown at the top of the graph.

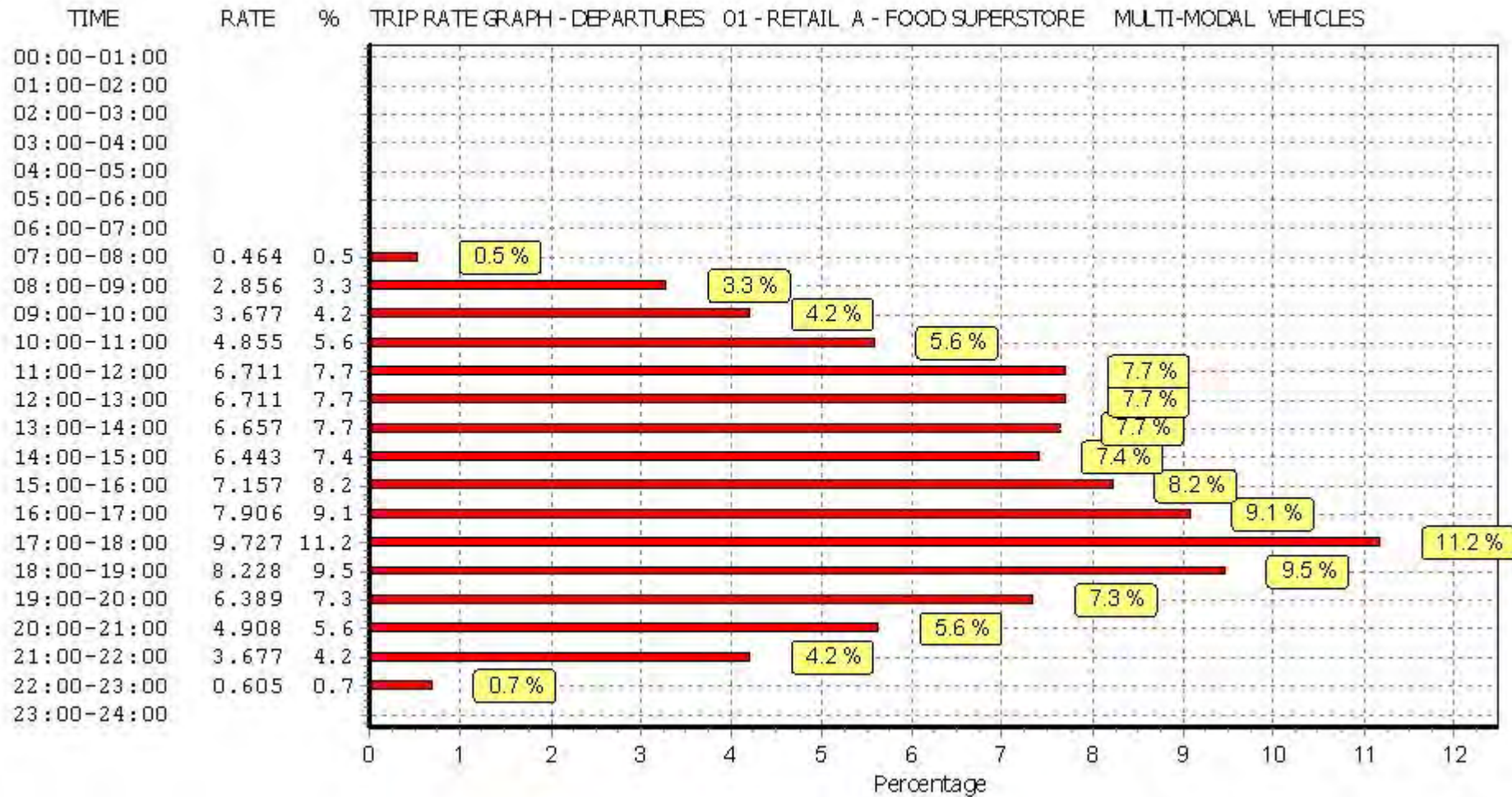

This graph is a visual representation of the trip rate calculation results screen. The same time periods and trip rates are displayed, but in addition there is an additional column showing the percentage of the total trip rate by individual time period, allowing peak periods to be easily identified through observation. Note that the type of count and the selected direction is shown at the top of the graph.

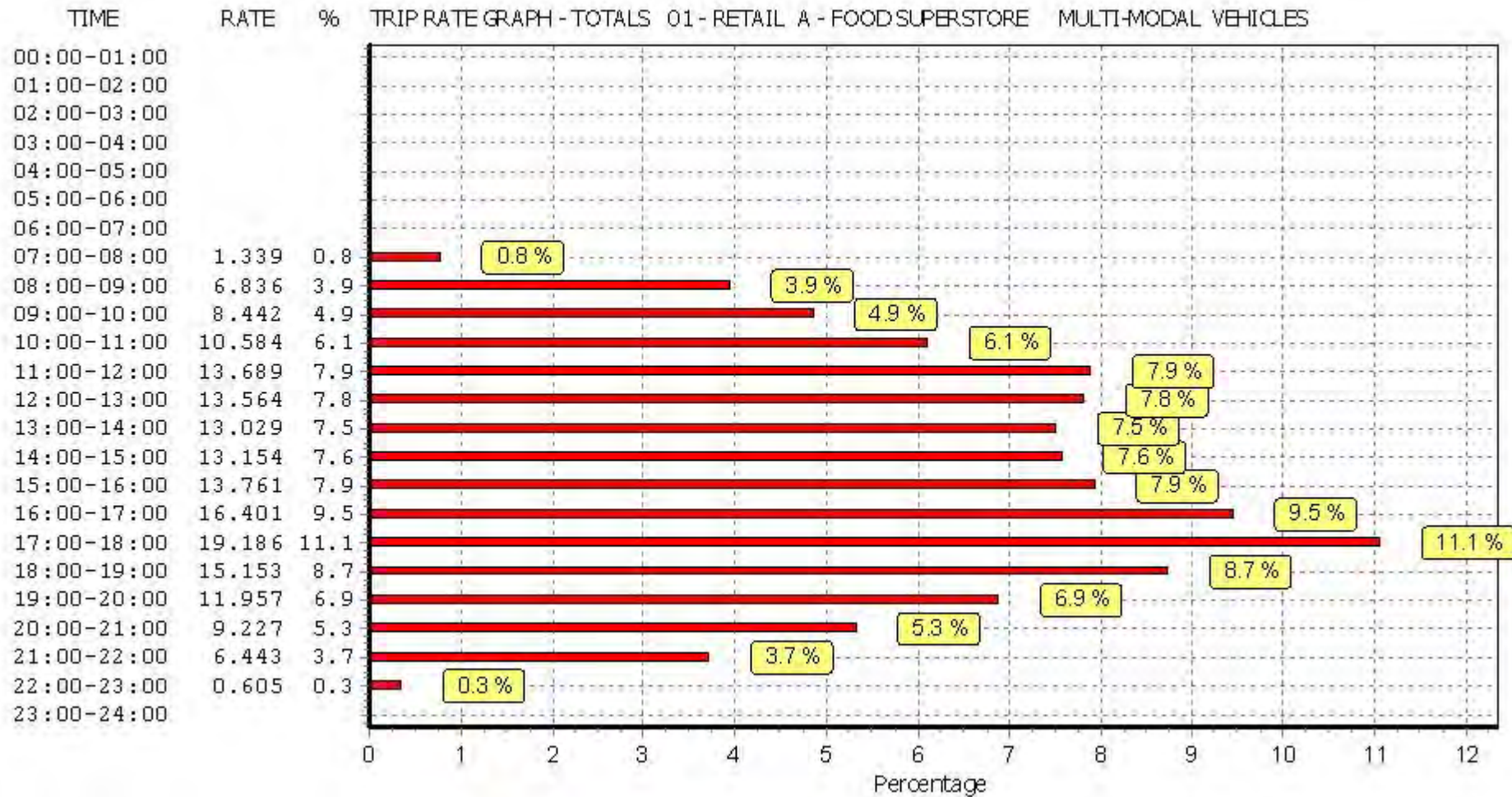

This graph is a visual representation of the trip rate calculation results screen. The same time periods and trip rates are displayed, but in addition there is an additional column showing the percentage of the total trip rate by individual time period, allowing peak periods to be easily identified through observation. Note that the type of count and the selected direction is shown at the top of the graph.

TRIP RATE for Land Use 01 - RETAIL/A - FOOD SUPERSTORE

MULTI-MODAL OGVS

Calculation factor: 100 sqm

BOLD print indicates peak (busiest) period

Time Range	ARRIVALS			DEPARTURES			TOTALS		
	No. Days	Ave. GFA	Trip Rate	No. Days	Ave. GFA	Trip Rate	No. Days	Ave. GFA	Trip Rate
00:00 - 01:00									
01:00 - 02:00									
02:00 - 03:00									
03:00 - 04:00									
04:00 - 05:00									
05:00 - 06:00									
06:00 - 07:00									
07:00 - 08:00	3	1868	0.036	3	1868	0.054	3	1868	0.090
08:00 - 09:00	3	1868	0.018	3	1868	0.018	3	1868	0.036
09:00 - 10:00	3	1868	0.036	3	1868	0.000	3	1868	0.036
10:00 - 11:00	3	1868	0.018	3	1868	0.071	3	1868	0.089
11:00 - 12:00	3	1868	0.000	3	1868	0.000	3	1868	0.000
12:00 - 13:00	3	1868	0.000	3	1868	0.018	3	1868	0.018
13:00 - 14:00	3	1868	0.000	3	1868	0.000	3	1868	0.000
14:00 - 15:00	3	1868	0.018	3	1868	0.000	3	1868	0.018
15:00 - 16:00	3	1868	0.018	3	1868	0.036	3	1868	0.054
16:00 - 17:00	3	1868	0.000	3	1868	0.000	3	1868	0.000
17:00 - 18:00	3	1868	0.000	3	1868	0.000	3	1868	0.000
18:00 - 19:00	3	1868	0.000	3	1868	0.000	3	1868	0.000
19:00 - 20:00	3	1868	0.000	3	1868	0.000	3	1868	0.000
20:00 - 21:00	3	1868	0.000	3	1868	0.000	3	1868	0.000
21:00 - 22:00	3	1868	0.018	3	1868	0.018	3	1868	0.036
22:00 - 23:00	1	1487	0.000	1	1487	0.000	1	1487	0.000
23:00 - 24:00									
Total Rates:			0.162			0.215			0.377

This section displays the trip rate results based on the selected set of surveys and the selected count type (shown just above the table). It is split by three main columns, representing arrivals trips, departures trips, and total trips (arrivals plus departures). Within each of these main columns are three sub-columns. These display the number of survey days where count data is included (per time period), the average value of the selected trip rate calculation parameter (per time period), and the trip rate result (per time period). Total trip rates (the sum of the column) are also displayed at the foot of the table.

To obtain a trip rate, the average (mean) trip rate parameter value (TRP) is first calculated for all selected survey days that have count data available for the stated time period. The average (mean) number of arrivals, departures or totals (whichever applies) is also calculated (COUNT) for all selected survey days that have count data available for the stated time period. Then, the average count is divided by the average trip rate parameter value, and multiplied by the stated calculation factor (shown just above the table and abbreviated here as FACT). So, the method is: $COUNT/TRP*FACT$. Trip rates are then rounded to 3 decimal places.

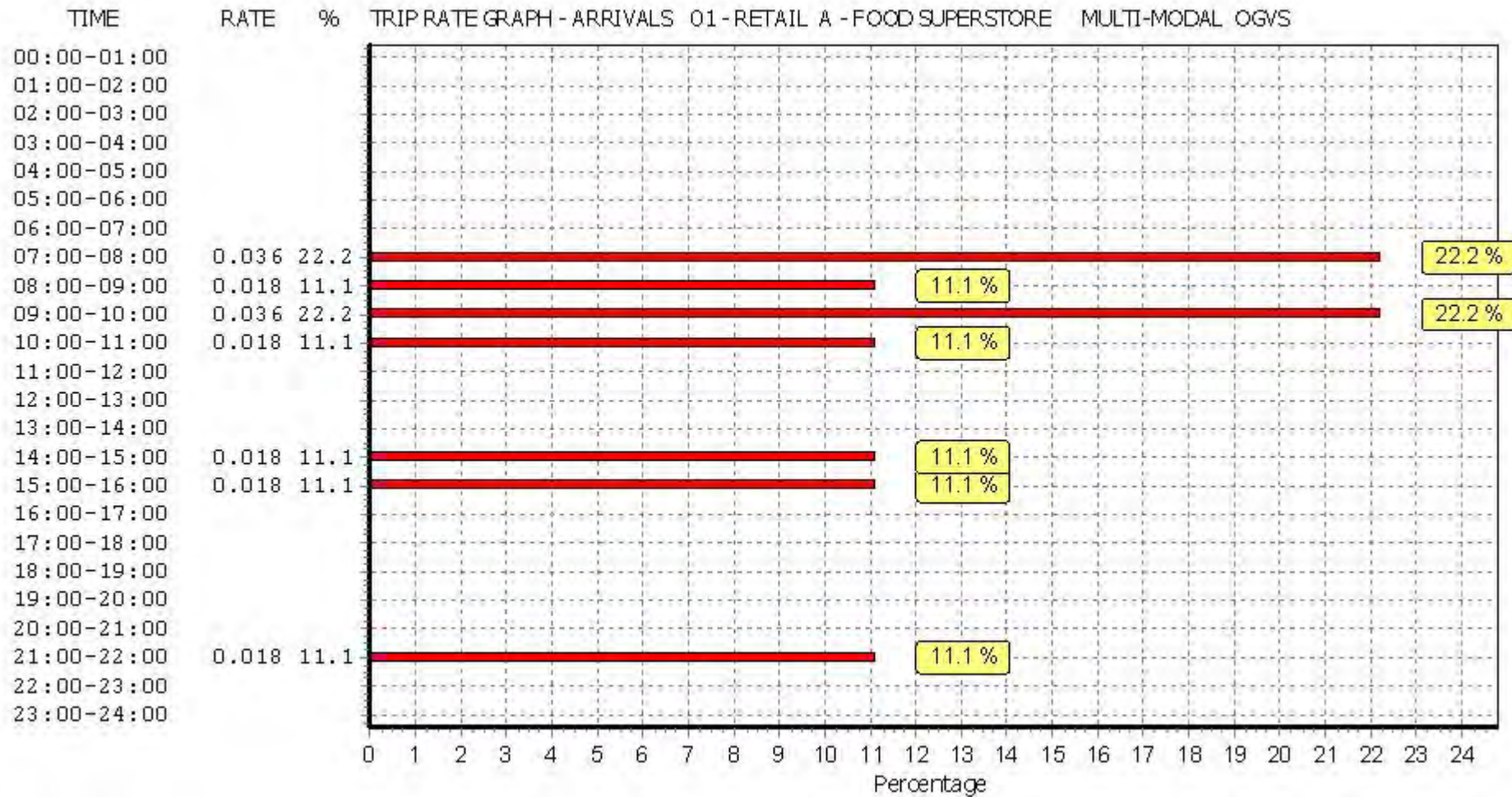

This graph is a visual representation of the trip rate calculation results screen. The same time periods and trip rates are displayed, but in addition there is an additional column showing the percentage of the total trip rate by individual time period, allowing peak periods to be easily identified through observation. Note that the type of count and the selected direction is shown at the top of the graph.

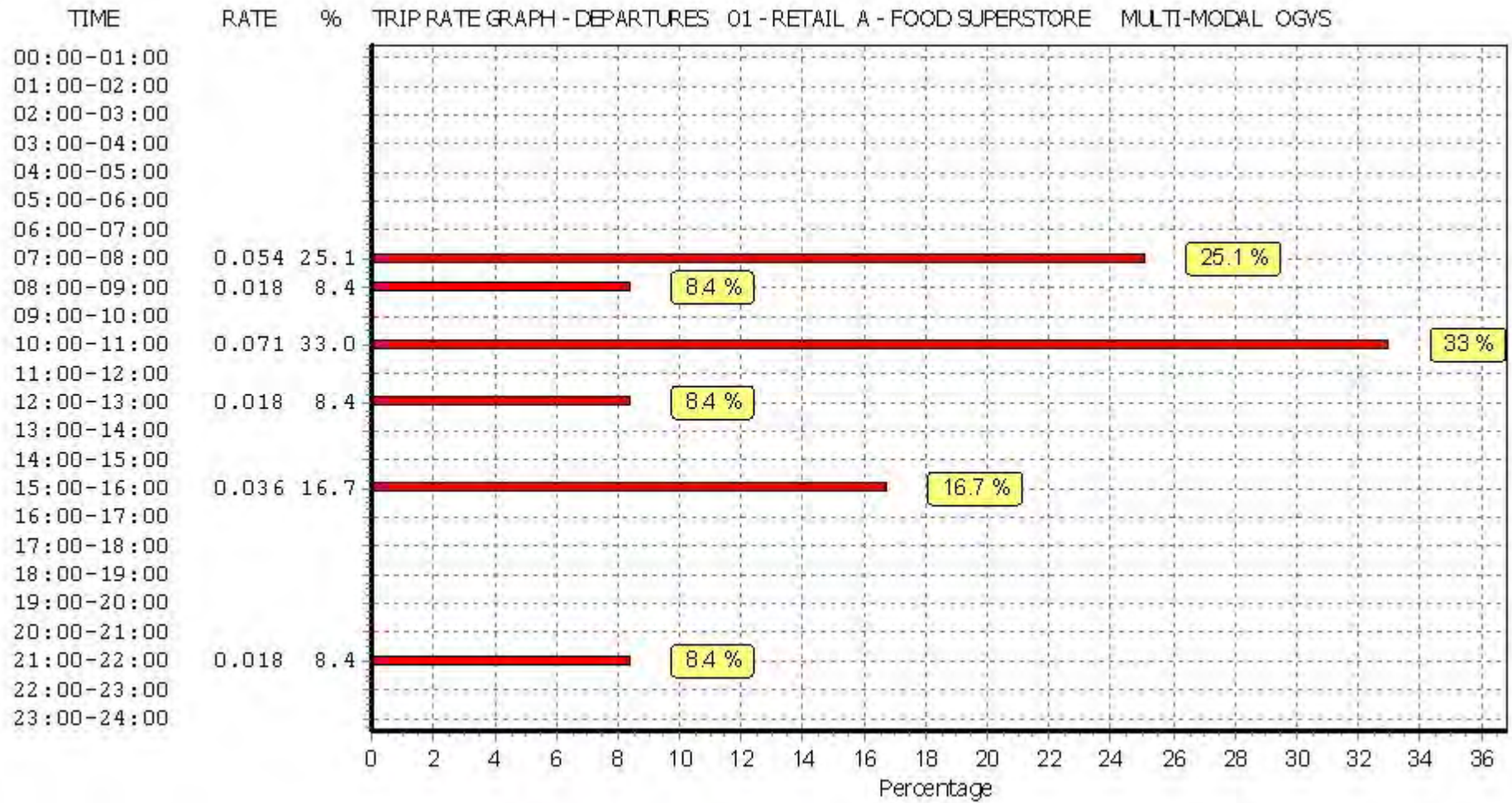

This graph is a visual representation of the trip rate calculation results screen. The same time periods and trip rates are displayed, but in addition there is an additional column showing the percentage of the total trip rate by individual time period, allowing peak periods to be easily identified through observation. Note that the type of count and the selected direction is shown at the top of the graph.

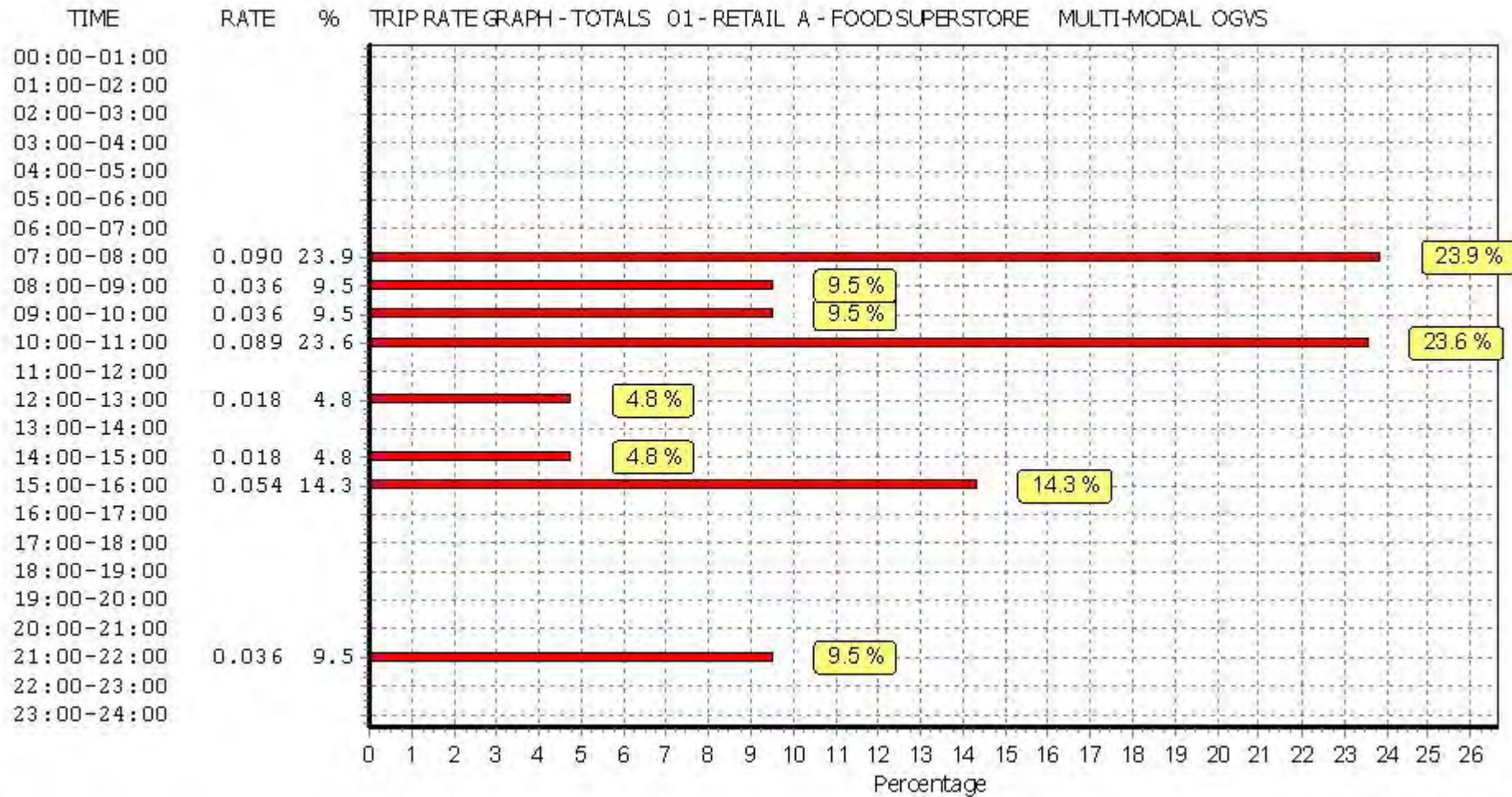

This graph is a visual representation of the trip rate calculation results screen. The same time periods and trip rates are displayed, but in addition there is an additional column showing the percentage of the total trip rate by individual time period, allowing peak periods to be easily identified through observation. Note that the type of count and the selected direction is shown at the top of the graph.

TRIP RATE for Land Use 01 - RETAIL/A - FOOD SUPERSTORE

MULTI-MODAL PSVS

Calculation factor: 100 sqm

BOLD print indicates peak (busiest) period

Time Range	ARRIVALS			DEPARTURES			TOTALS		
	No. Days	Ave. GFA	Trip Rate	No. Days	Ave. GFA	Trip Rate	No. Days	Ave. GFA	Trip Rate
00:00 - 01:00									
01:00 - 02:00									
02:00 - 03:00									
03:00 - 04:00									
04:00 - 05:00									
05:00 - 06:00									
06:00 - 07:00									
07:00 - 08:00	3	1868	0.000	3	1868	0.000	3	1868	0.000
08:00 - 09:00	3	1868	0.000	3	1868	0.000	3	1868	0.000
09:00 - 10:00	3	1868	0.071	3	1868	0.071	3	1868	0.142
10:00 - 11:00	3	1868	0.071	3	1868	0.071	3	1868	0.142
11:00 - 12:00	3	1868	0.071	3	1868	0.071	3	1868	0.142
12:00 - 13:00	3	1868	0.071	3	1868	0.071	3	1868	0.142
13:00 - 14:00	3	1868	0.071	3	1868	0.071	3	1868	0.142
14:00 - 15:00	3	1868	0.071	3	1868	0.071	3	1868	0.142
15:00 - 16:00	3	1868	0.071	3	1868	0.071	3	1868	0.142
16:00 - 17:00	3	1868	0.071	3	1868	0.071	3	1868	0.142
17:00 - 18:00	3	1868	0.089	3	1868	0.071	3	1868	0.160
18:00 - 19:00	3	1868	0.036	3	1868	0.054	3	1868	0.090
19:00 - 20:00	3	1868	0.000	3	1868	0.000	3	1868	0.000
20:00 - 21:00	3	1868	0.000	3	1868	0.000	3	1868	0.000
21:00 - 22:00	3	1868	0.000	3	1868	0.000	3	1868	0.000
22:00 - 23:00	1	1487	0.000	1	1487	0.000	1	1487	0.000
23:00 - 24:00									
Total Rates:			0.693			0.693			1.386

This section displays the trip rate results based on the selected set of surveys and the selected count type (shown just above the table). It is split by three main columns, representing arrivals trips, departures trips, and total trips (arrivals plus departures). Within each of these main columns are three sub-columns. These display the number of survey days where count data is included (per time period), the average value of the selected trip rate calculation parameter (per time period), and the trip rate result (per time period). Total trip rates (the sum of the column) are also displayed at the foot of the table.

To obtain a trip rate, the average (mean) trip rate parameter value (TRP) is first calculated for all selected survey days that have count data available for the stated time period. The average (mean) number of arrivals, departures or totals (whichever applies) is also calculated (COUNT) for all selected survey days that have count data available for the stated time period. Then, the average count is divided by the average trip rate parameter value, and multiplied by the stated calculation factor (shown just above the table and abbreviated here as FACT). So, the method is: $COUNT/TRP*FACT$. Trip rates are then rounded to 3 decimal places.

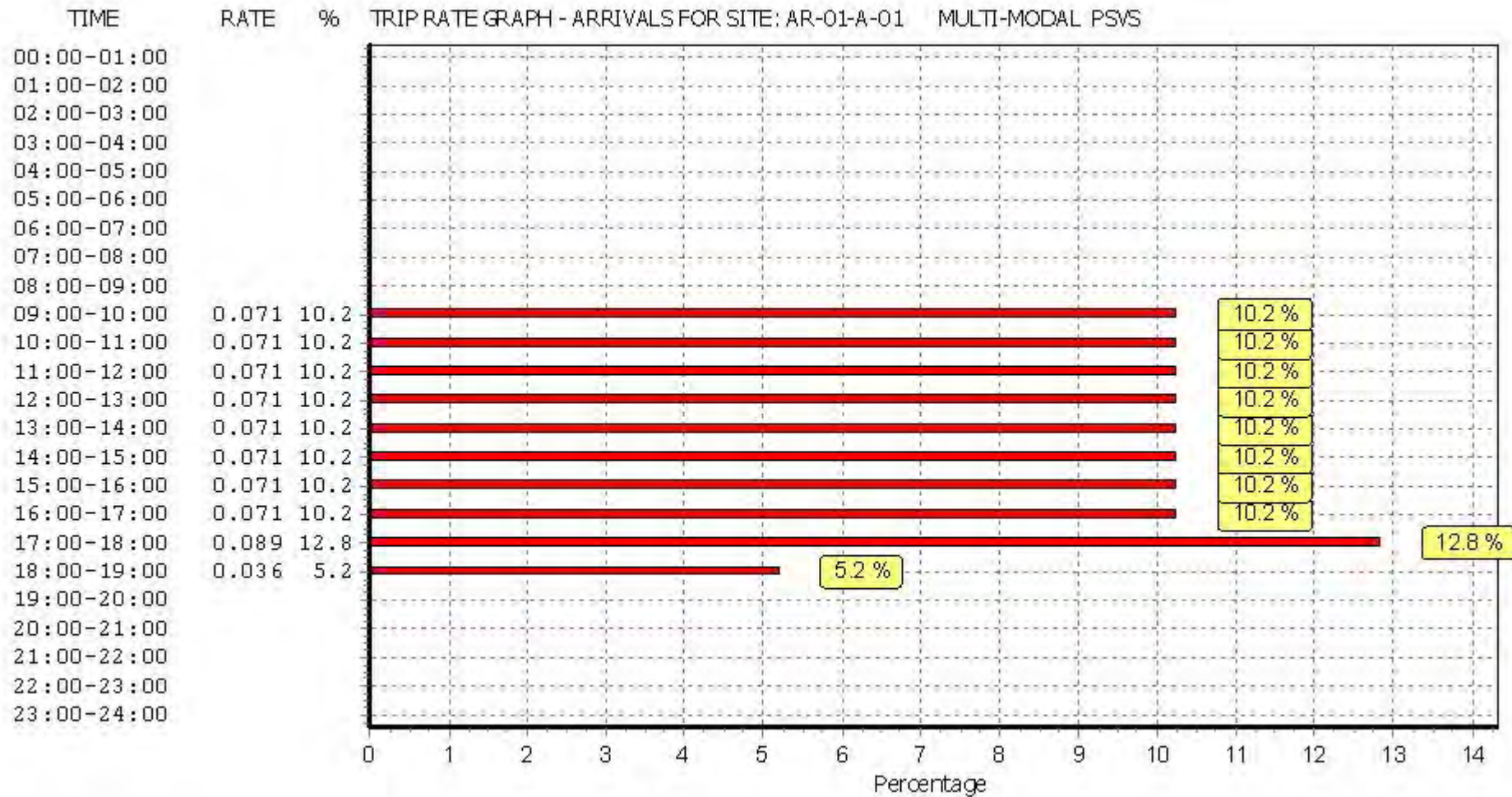

This graph is a visual representation of the trip rate calculation results screen. The same time periods and trip rates are displayed, but in addition there is an additional column showing the percentage of the total trip rate by individual time period, allowing peak periods to be easily identified through observation. Note that the type of count and the selected direction is shown at the top of the graph.

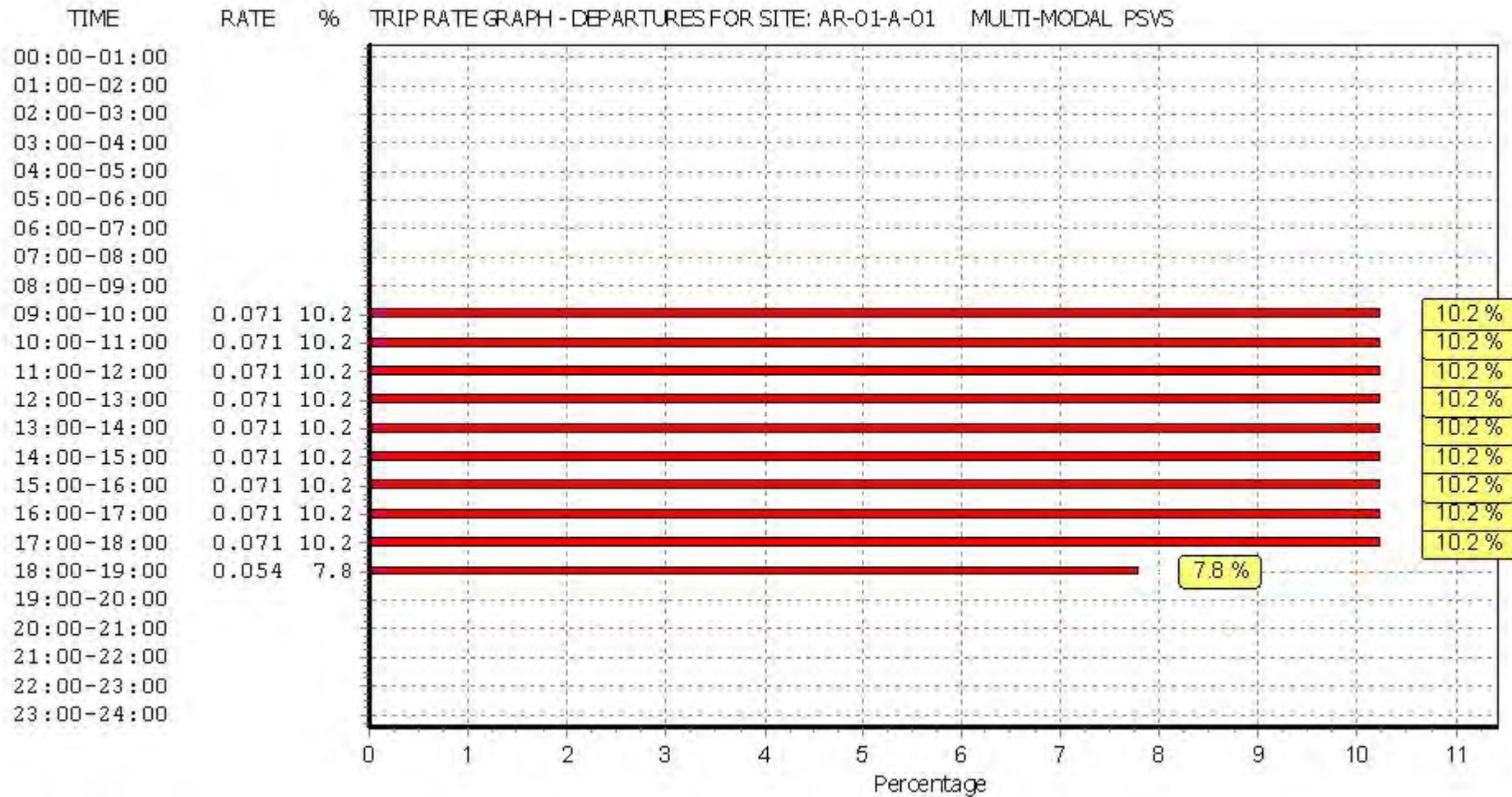

This graph is a visual representation of the trip rate calculation results screen. The same time periods and trip rates are displayed, but in addition there is an additional column showing the percentage of the total trip rate by individual time period, allowing peak periods to be easily identified through observation. Note that the type of count and the selected direction is shown at the top of the graph.

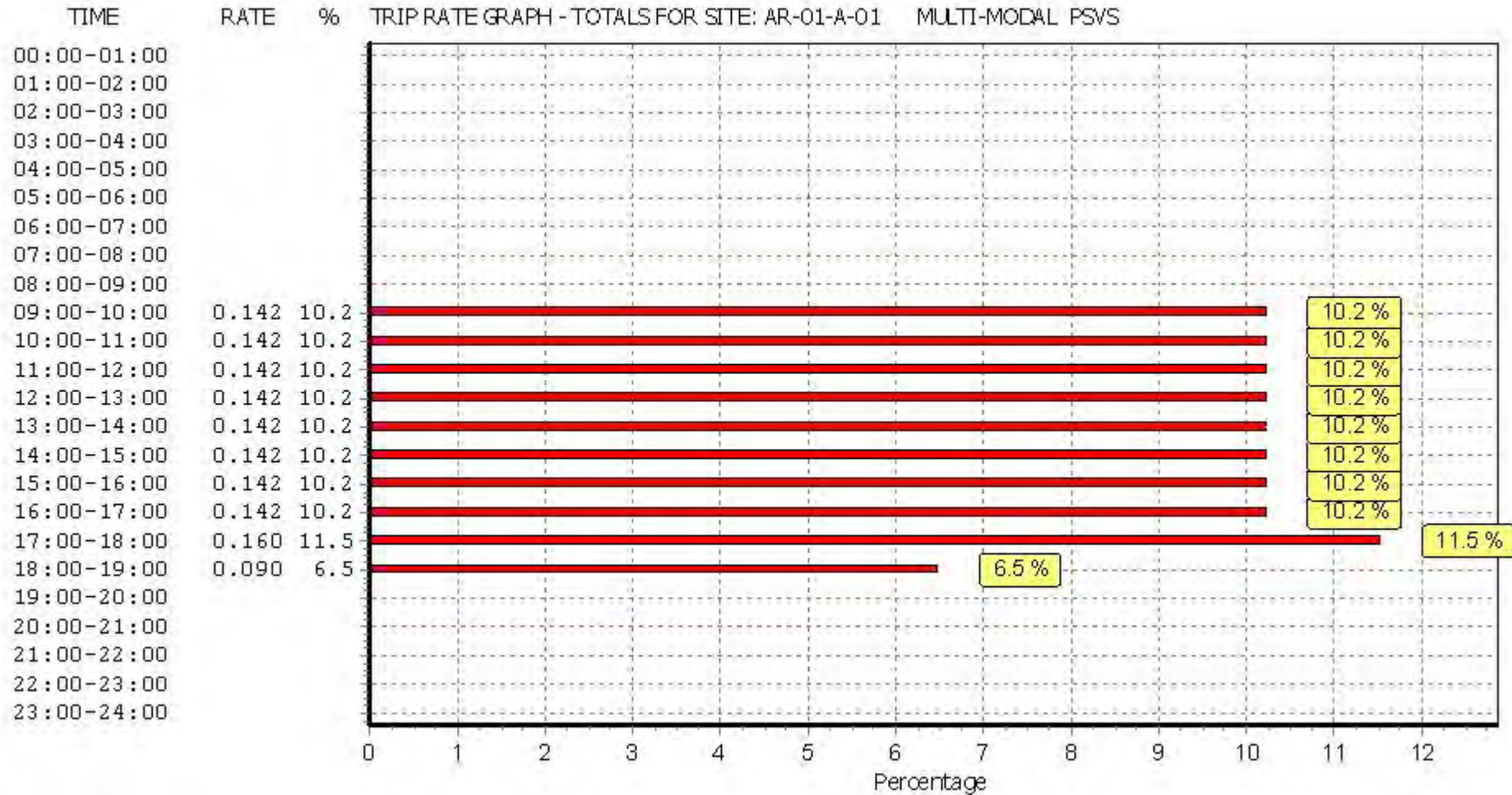

This graph is a visual representation of the trip rate calculation results screen. The same time periods and trip rates are displayed, but in addition there is an additional column showing the percentage of the total trip rate by individual time period, allowing peak periods to be easily identified through observation. Note that the type of count and the selected direction is shown at the top of the graph.

TRIP RATE for Land Use 01 - RETAIL/A - FOOD SUPERSTORE

MULTI-MODAL CYCLISTS

Calculation factor: 100 sqm

BOLD print indicates peak (busiest) period

Time Range	ARRIVALS			DEPARTURES			TOTALS		
	No. Days	Ave. GFA	Trip Rate	No. Days	Ave. GFA	Trip Rate	No. Days	Ave. GFA	Trip Rate
00:00 - 01:00									
01:00 - 02:00									
02:00 - 03:00									
03:00 - 04:00									
04:00 - 05:00									
05:00 - 06:00									
06:00 - 07:00									
07:00 - 08:00	3	1868	0.054	3	1868	0.036	3	1868	0.090
08:00 - 09:00	3	1868	0.054	3	1868	0.036	3	1868	0.090
09:00 - 10:00	3	1868	0.000	3	1868	0.018	3	1868	0.018
10:00 - 11:00	3	1868	0.000	3	1868	0.036	3	1868	0.036
11:00 - 12:00	3	1868	0.071	3	1868	0.071	3	1868	0.142
12:00 - 13:00	3	1868	0.018	3	1868	0.036	3	1868	0.054
13:00 - 14:00	3	1868	0.089	3	1868	0.054	3	1868	0.143
14:00 - 15:00	3	1868	0.107	3	1868	0.054	3	1868	0.161
15:00 - 16:00	3	1868	0.036	3	1868	0.036	3	1868	0.072
16:00 - 17:00	3	1868	0.036	3	1868	0.036	3	1868	0.072
17:00 - 18:00	3	1868	0.054	3	1868	0.036	3	1868	0.090
18:00 - 19:00	3	1868	0.071	3	1868	0.036	3	1868	0.107
19:00 - 20:00	3	1868	0.054	3	1868	0.000	3	1868	0.054
20:00 - 21:00	3	1868	0.054	3	1868	0.089	3	1868	0.143
21:00 - 22:00	3	1868	0.071	3	1868	0.107	3	1868	0.178
22:00 - 23:00	1	1487	0.000	1	1487	0.000	1	1487	0.000
23:00 - 24:00									
Total Rates:			0.769			0.681			1.450

This section displays the trip rate results based on the selected set of surveys and the selected count type (shown just above the table). It is split by three main columns, representing arrivals trips, departures trips, and total trips (arrivals plus departures). Within each of these main columns are three sub-columns. These display the number of survey days where count data is included (per time period), the average value of the selected trip rate calculation parameter (per time period), and the trip rate result (per time period). Total trip rates (the sum of the column) are also displayed at the foot of the table.

To obtain a trip rate, the average (mean) trip rate parameter value (TRP) is first calculated for all selected survey days that have count data available for the stated time period. The average (mean) number of arrivals, departures or totals (whichever applies) is also calculated (COUNT) for all selected survey days that have count data available for the stated time period. Then, the average count is divided by the average trip rate parameter value, and multiplied by the stated calculation factor (shown just above the table and abbreviated here as FACT). So, the method is: $COUNT/TRP*FACT$. Trip rates are then rounded to 3 decimal places.

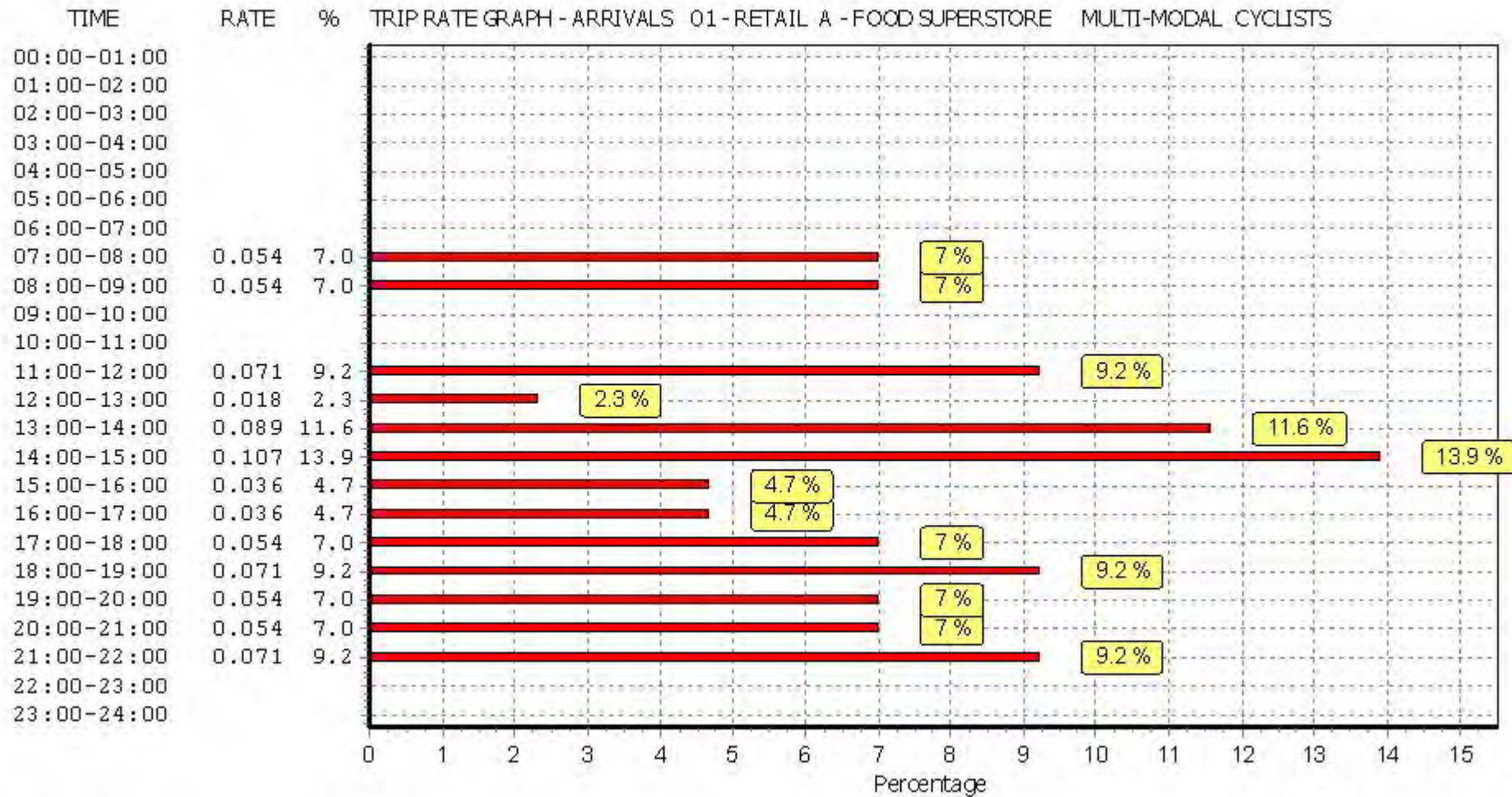

This graph is a visual representation of the trip rate calculation results screen. The same time periods and trip rates are displayed, but in addition there is an additional column showing the percentage of the total trip rate by individual time period, allowing peak periods to be easily identified through observation. Note that the type of count and the selected direction is shown at the top of the graph.

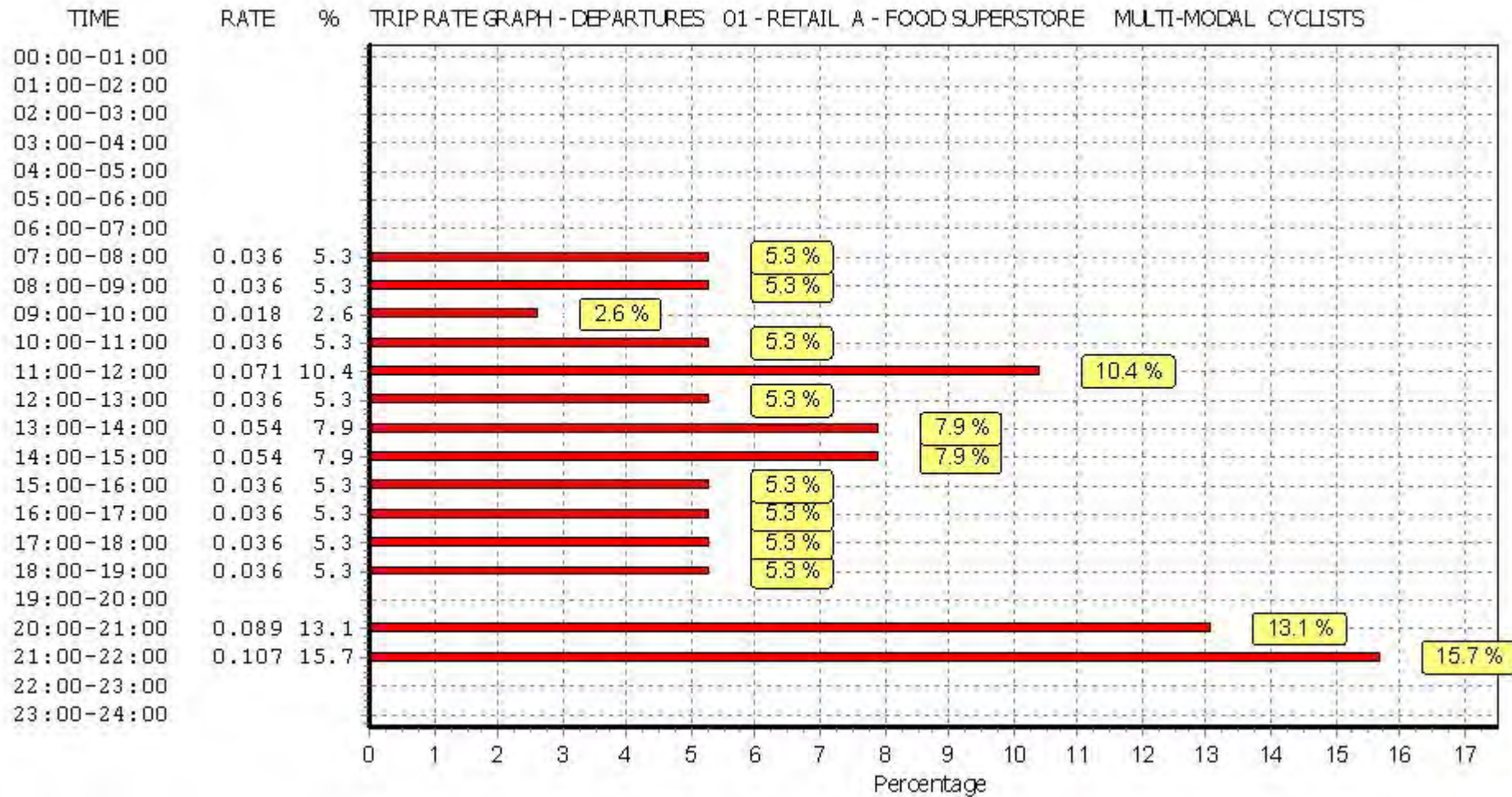

This graph is a visual representation of the trip rate calculation results screen. The same time periods and trip rates are displayed, but in addition there is an additional column showing the percentage of the total trip rate by individual time period, allowing peak periods to be easily identified through observation. Note that the type of count and the selected direction is shown at the top of the graph.

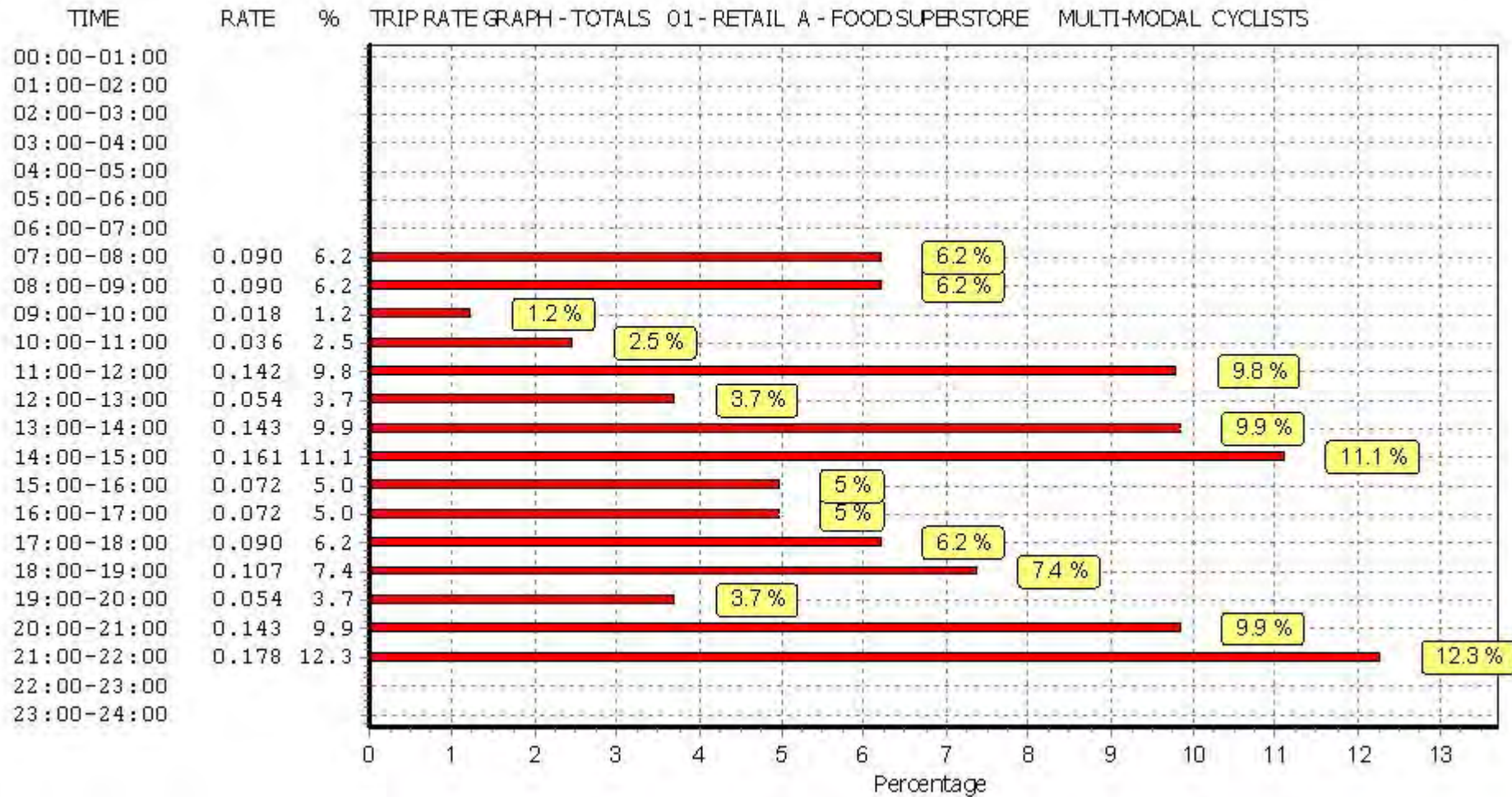

This graph is a visual representation of the trip rate calculation results screen. The same time periods and trip rates are displayed, but in addition there is an additional column showing the percentage of the total trip rate by individual time period, allowing peak periods to be easily identified through observation. Note that the type of count and the selected direction is shown at the top of the graph.

TRIP RATE for Land Use 01 - RETAIL/A - FOOD SUPERSTORE

MULTI-MODAL VEHICLE OCCUPANTS

Calculation factor: 100 sqm

BOLD print indicates peak (busiest) period

Time Range	ARRIVALS			DEPARTURES			TOTALS		
	No. Days	Ave. GFA	Trip Rate	No. Days	Ave. GFA	Trip Rate	No. Days	Ave. GFA	Trip Rate
00:00 - 01:00									
01:00 - 02:00									
02:00 - 03:00									
03:00 - 04:00									
04:00 - 05:00									
05:00 - 06:00									
06:00 - 07:00									
07:00 - 08:00	3	1868	1.124	3	1868	0.660	3	1868	1.784
08:00 - 09:00	3	1868	5.051	3	1868	3.694	3	1868	8.745
09:00 - 10:00	3	1868	5.943	3	1868	4.462	3	1868	10.405
10:00 - 11:00	3	1868	7.692	3	1868	6.550	3	1868	14.242
11:00 - 12:00	3	1868	9.780	3	1868	9.388	3	1868	19.168
12:00 - 13:00	3	1868	10.155	3	1868	9.548	3	1868	19.703
13:00 - 14:00	3	1868	8.710	3	1868	9.477	3	1868	18.187
14:00 - 15:00	3	1868	9.299	3	1868	8.835	3	1868	18.134
15:00 - 16:00	3	1868	10.494	3	1868	11.351	3	1868	21.845
16:00 - 17:00	3	1868	12.725	3	1868	12.136	3	1868	24.861
17:00 - 18:00	3	1868	12.672	3	1868	15.028	3	1868	27.700
18:00 - 19:00	3	1868	10.102	3	1868	12.618	3	1868	22.720
19:00 - 20:00	3	1868	8.817	3	1868	9.923	3	1868	18.740
20:00 - 21:00	3	1868	7.282	3	1868	8.460	3	1868	15.742
21:00 - 22:00	3	1868	4.676	3	1868	6.122	3	1868	10.798
22:00 - 23:00	1	1487	0.000	1	1487	0.740	1	1487	0.740
23:00 - 24:00									
Total Rates:			124.522			128.992			253.514

This section displays the trip rate results based on the selected set of surveys and the selected count type (shown just above the table). It is split by three main columns, representing arrivals trips, departures trips, and total trips (arrivals plus departures). Within each of these main columns are three sub-columns. These display the number of survey days where count data is included (per time period), the average value of the selected trip rate calculation parameter (per time period), and the trip rate result (per time period). Total trip rates (the sum of the column) are also displayed at the foot of the table.

To obtain a trip rate, the average (mean) trip rate parameter value (TRP) is first calculated for all selected survey days that have count data available for the stated time period. The average (mean) number of arrivals, departures or totals (whichever applies) is also calculated (COUNT) for all selected survey days that have count data available for the stated time period. Then, the average count is divided by the average trip rate parameter value, and multiplied by the stated calculation factor (shown just above the table and abbreviated here as FACT). So, the method is: $COUNT/TRP*FACT$. Trip rates are then rounded to 3 decimal places.

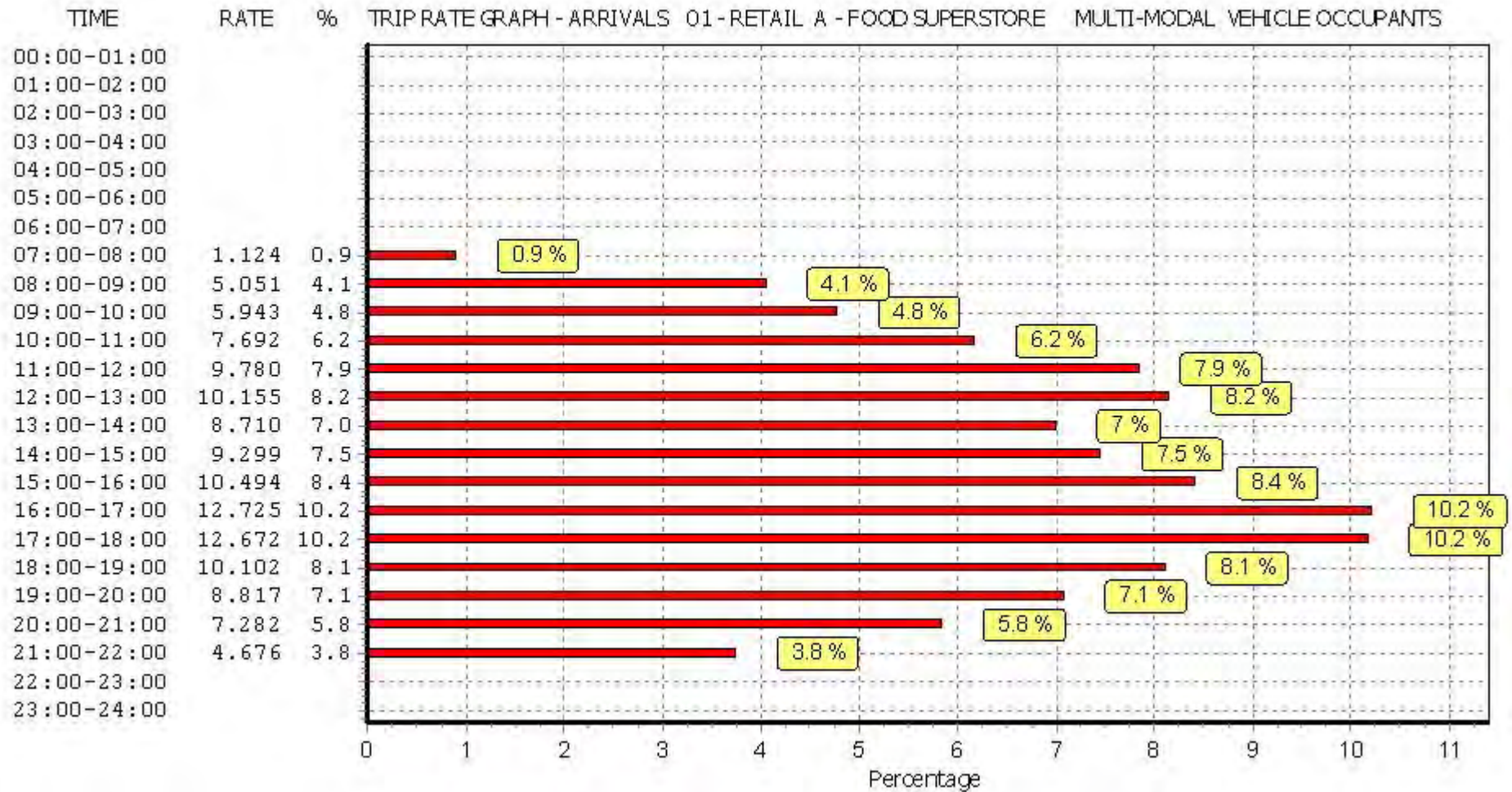

This graph is a visual representation of the trip rate calculation results screen. The same time periods and trip rates are displayed, but in addition there is an additional column showing the percentage of the total trip rate by individual time period, allowing peak periods to be easily identified through observation. Note that the type of count and the selected direction is shown at the top of the graph.

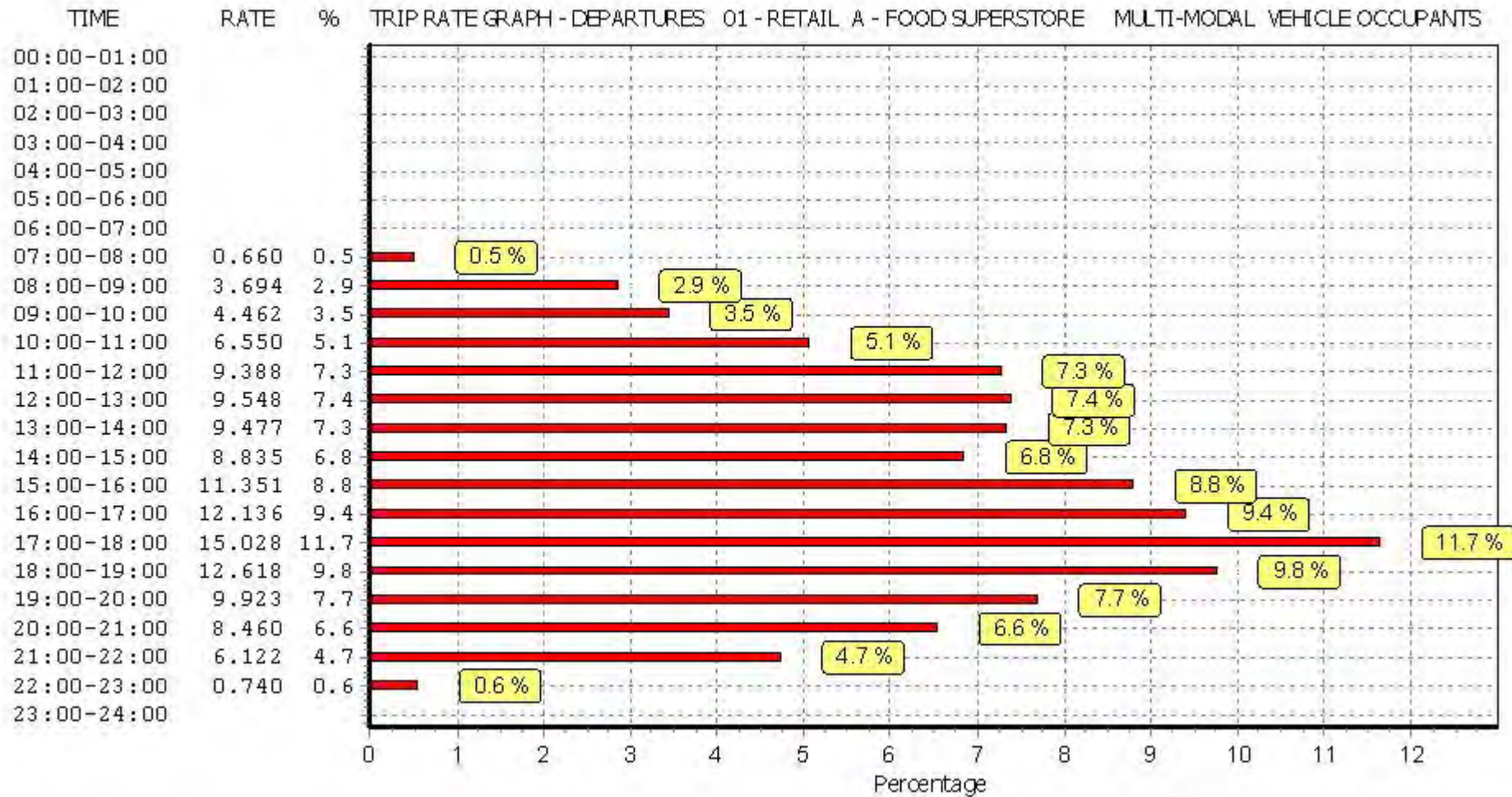

This graph is a visual representation of the trip rate calculation results screen. The same time periods and trip rates are displayed, but in addition there is an additional column showing the percentage of the total trip rate by individual time period, allowing peak periods to be easily identified through observation. Note that the type of count and the selected direction is shown at the top of the graph.

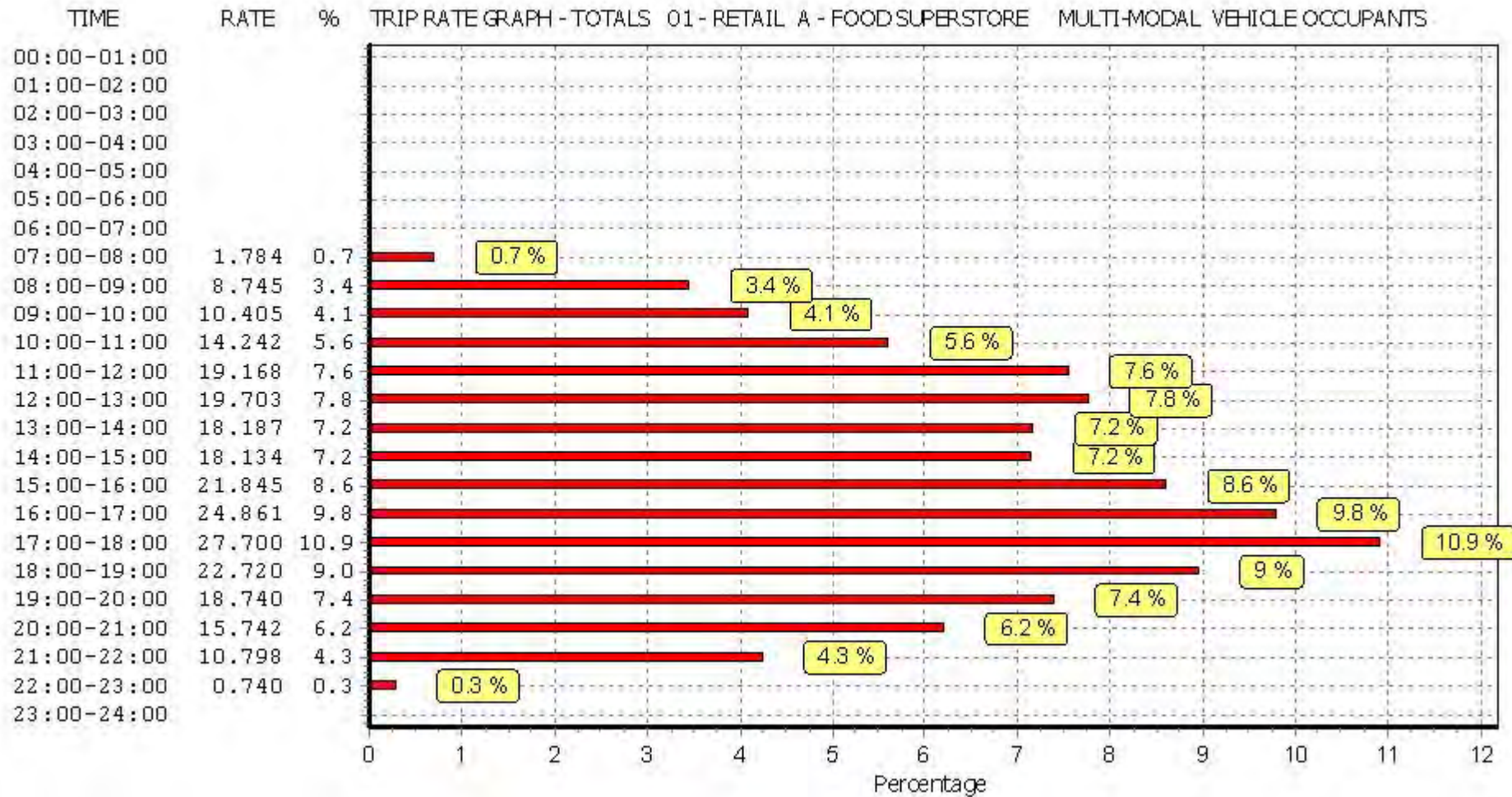

This graph is a visual representation of the trip rate calculation results screen. The same time periods and trip rates are displayed, but in addition there is an additional column showing the percentage of the total trip rate by individual time period, allowing peak periods to be easily identified through observation. Note that the type of count and the selected direction is shown at the top of the graph.

TRIP RATE for Land Use 01 - RETAIL/A - FOOD SUPERSTORE

MULTI-MODAL PEDESTRIANS

Calculation factor: 100 sqm

BOLD print indicates peak (busiest) period

Time Range	ARRIVALS			DEPARTURES			TOTALS		
	No. Days	Ave. GFA	Trip Rate	No. Days	Ave. GFA	Trip Rate	No. Days	Ave. GFA	Trip Rate
00:00 - 01:00									
01:00 - 02:00									
02:00 - 03:00									
03:00 - 04:00									
04:00 - 05:00									
05:00 - 06:00									
06:00 - 07:00									
07:00 - 08:00	3	1868	0.161	3	1868	0.161	3	1868	0.322
08:00 - 09:00	3	1868	1.339	3	1868	1.588	3	1868	2.927
09:00 - 10:00	3	1868	1.285	3	1868	1.214	3	1868	2.499
10:00 - 11:00	3	1868	1.464	3	1868	1.481	3	1868	2.945
11:00 - 12:00	3	1868	1.446	3	1868	1.249	3	1868	2.695
12:00 - 13:00	3	1868	1.820	3	1868	2.142	3	1868	3.962
13:00 - 14:00	3	1868	1.588	3	1868	1.464	3	1868	3.052
14:00 - 15:00	3	1868	1.214	3	1868	1.285	3	1868	2.499
15:00 - 16:00	3	1868	2.267	3	1868	1.945	3	1868	4.212
16:00 - 17:00	3	1868	1.481	3	1868	1.481	3	1868	2.962
17:00 - 18:00	3	1868	2.195	3	1868	1.678	3	1868	3.873
18:00 - 19:00	3	1868	1.321	3	1868	1.588	3	1868	2.909
19:00 - 20:00	3	1868	0.750	3	1868	0.839	3	1868	1.589
20:00 - 21:00	3	1868	0.964	3	1868	1.107	3	1868	2.071
21:00 - 22:00	3	1868	0.464	3	1868	0.500	3	1868	0.964
22:00 - 23:00	1	1487	0.269	1	1487	0.403	1	1487	0.672
23:00 - 24:00									
Total Rates:			20.028			20.125			40.153

This section displays the trip rate results based on the selected set of surveys and the selected count type (shown just above the table). It is split by three main columns, representing arrivals trips, departures trips, and total trips (arrivals plus departures). Within each of these main columns are three sub-columns. These display the number of survey days where count data is included (per time period), the average value of the selected trip rate calculation parameter (per time period), and the trip rate result (per time period). Total trip rates (the sum of the column) are also displayed at the foot of the table.

To obtain a trip rate, the average (mean) trip rate parameter value (TRP) is first calculated for all selected survey days that have count data available for the stated time period. The average (mean) number of arrivals, departures or totals (whichever applies) is also calculated (COUNT) for all selected survey days that have count data available for the stated time period. Then, the average count is divided by the average trip rate parameter value, and multiplied by the stated calculation factor (shown just above the table and abbreviated here as FACT). So, the method is: $COUNT/TRP*FACT$. Trip rates are then rounded to 3 decimal places.

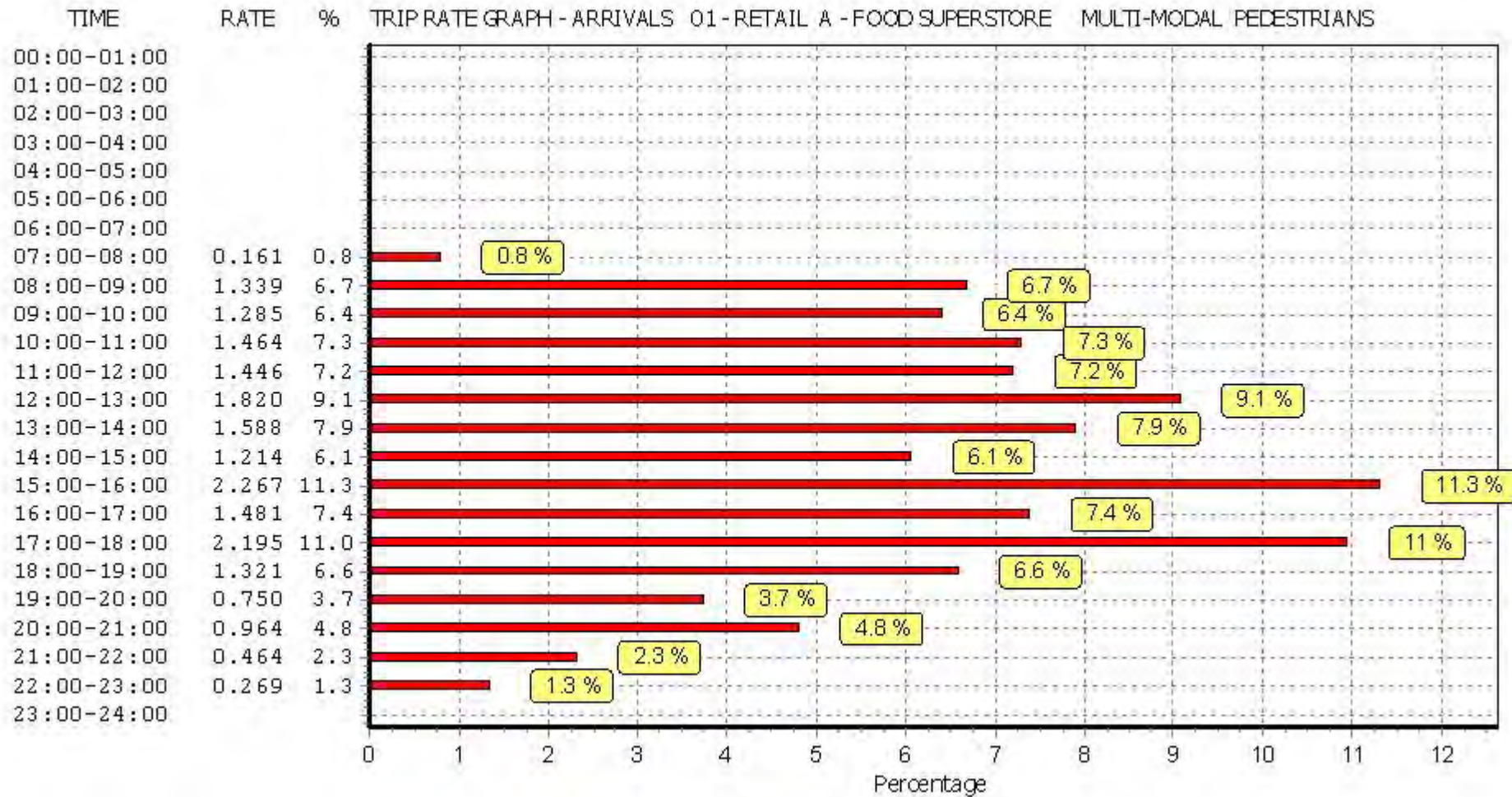

This graph is a visual representation of the trip rate calculation results screen. The same time periods and trip rates are displayed, but in addition there is an additional column showing the percentage of the total trip rate by individual time period, allowing peak periods to be easily identified through observation. Note that the type of count and the selected direction is shown at the top of the graph.

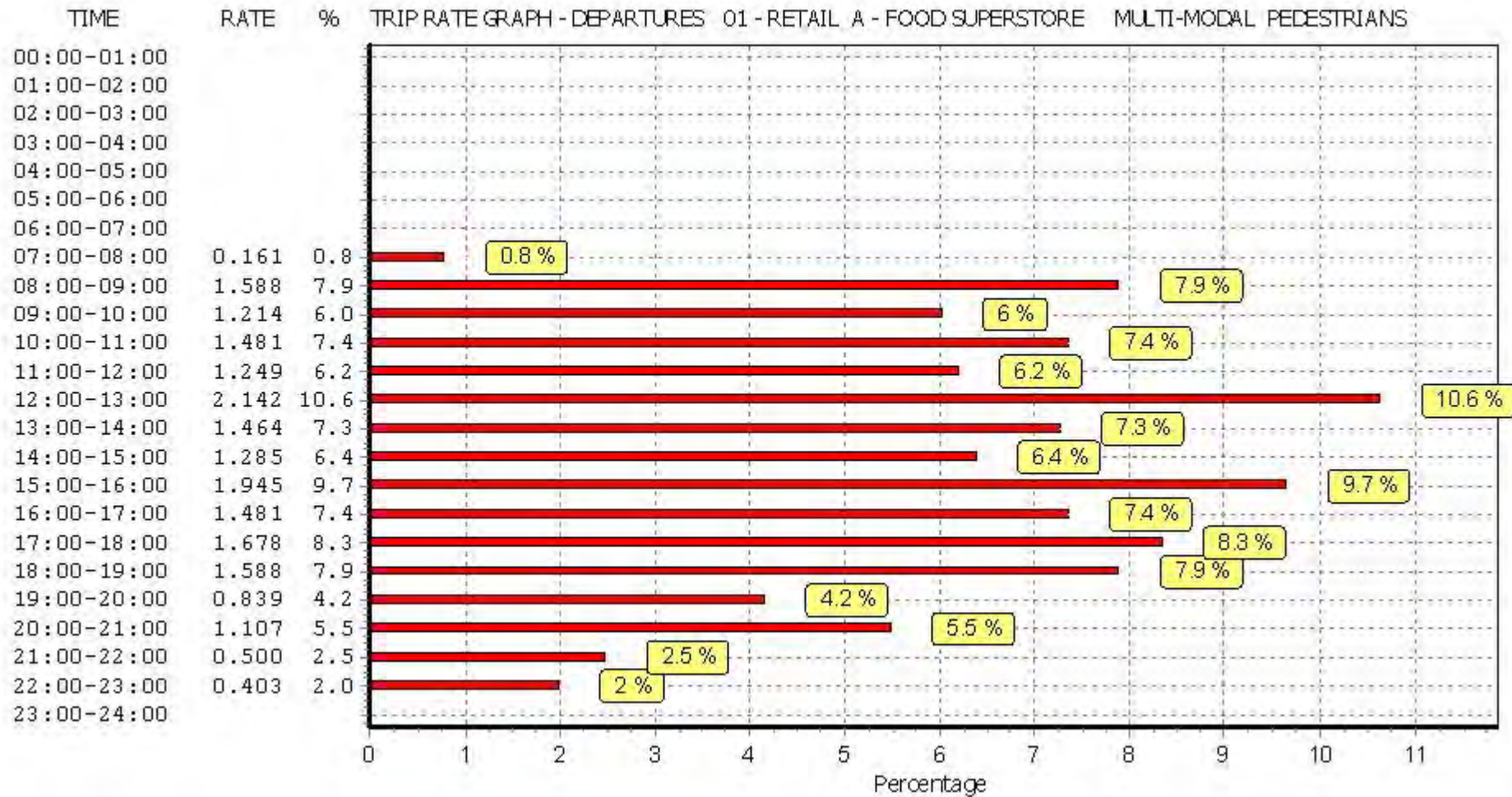

This graph is a visual representation of the trip rate calculation results screen. The same time periods and trip rates are displayed, but in addition there is an additional column showing the percentage of the total trip rate by individual time period, allowing peak periods to be easily identified through observation. Note that the type of count and the selected direction is shown at the top of the graph.

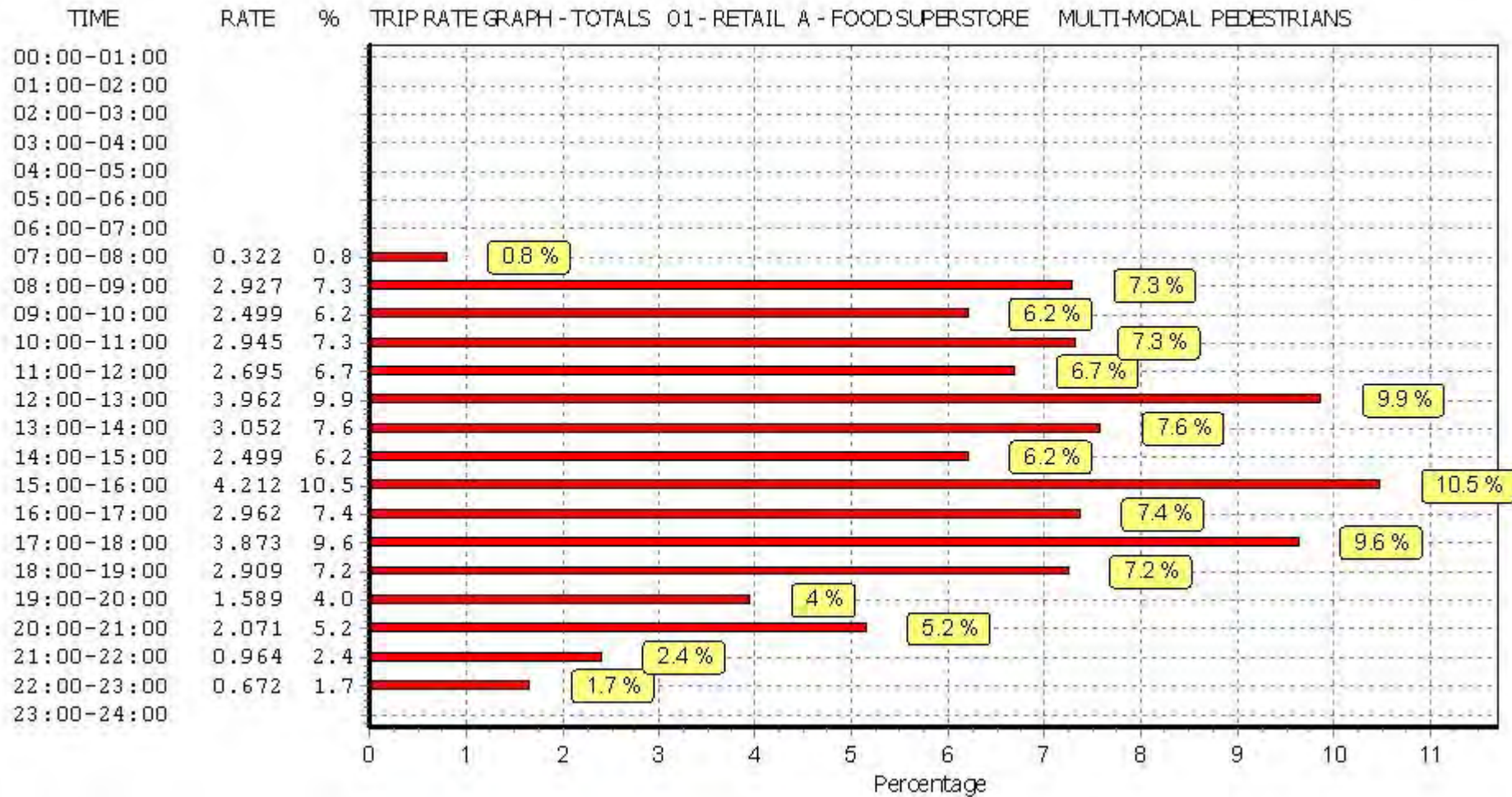

This graph is a visual representation of the trip rate calculation results screen. The same time periods and trip rates are displayed, but in addition there is an additional column showing the percentage of the total trip rate by individual time period, allowing peak periods to be easily identified through observation. Note that the type of count and the selected direction is shown at the top of the graph.

TRIP RATE for Land Use 01 - RETAIL/A - FOOD SUPERSTORE

MULTI-MODAL PUBLIC TRANSPORT USERS

Calculation factor: 100 sqm

BOLD print indicates peak (busiest) period

Time Range	ARRIVALS			DEPARTURES			TOTALS		
	No. Days	Ave. GFA	Trip Rate	No. Days	Ave. GFA	Trip Rate	No. Days	Ave. GFA	Trip Rate
00:00 - 01:00									
01:00 - 02:00									
02:00 - 03:00									
03:00 - 04:00									
04:00 - 05:00									
05:00 - 06:00									
06:00 - 07:00									
07:00 - 08:00	3	1868	0.000	3	1868	0.036	3	1868	0.036
08:00 - 09:00	3	1868	0.875	3	1868	0.660	3	1868	1.535
09:00 - 10:00	3	1868	0.143	3	1868	0.036	3	1868	0.179
10:00 - 11:00	3	1868	0.161	3	1868	0.107	3	1868	0.268
11:00 - 12:00	3	1868	0.125	3	1868	0.071	3	1868	0.196
12:00 - 13:00	3	1868	0.196	3	1868	0.161	3	1868	0.357
13:00 - 14:00	3	1868	0.268	3	1868	0.214	3	1868	0.482
14:00 - 15:00	3	1868	0.161	3	1868	0.107	3	1868	0.268
15:00 - 16:00	3	1868	0.018	3	1868	0.000	3	1868	0.018
16:00 - 17:00	3	1868	0.071	3	1868	0.018	3	1868	0.089
17:00 - 18:00	3	1868	0.250	3	1868	0.018	3	1868	0.268
18:00 - 19:00	3	1868	0.446	3	1868	0.000	3	1868	0.446
19:00 - 20:00	3	1868	0.000	3	1868	0.036	3	1868	0.036
20:00 - 21:00	3	1868	0.000	3	1868	0.000	3	1868	0.000
21:00 - 22:00	3	1868	0.000	3	1868	0.000	3	1868	0.000
22:00 - 23:00	1	1487	0.000	1	1487	0.000	1	1487	0.000
23:00 - 24:00									
Total Rates:			2.714			1.464			4.178

This section displays the trip rate results based on the selected set of surveys and the selected count type (shown just above the table). It is split by three main columns, representing arrivals trips, departures trips, and total trips (arrivals plus departures). Within each of these main columns are three sub-columns. These display the number of survey days where count data is included (per time period), the average value of the selected trip rate calculation parameter (per time period), and the trip rate result (per time period). Total trip rates (the sum of the column) are also displayed at the foot of the table.

To obtain a trip rate, the average (mean) trip rate parameter value (TRP) is first calculated for all selected survey days that have count data available for the stated time period. The average (mean) number of arrivals, departures or totals (whichever applies) is also calculated (COUNT) for all selected survey days that have count data available for the stated time period. Then, the average count is divided by the average trip rate parameter value, and multiplied by the stated calculation factor (shown just above the table and abbreviated here as FACT). So, the method is: $COUNT/TRP*FACT$. Trip rates are then rounded to 3 decimal places.

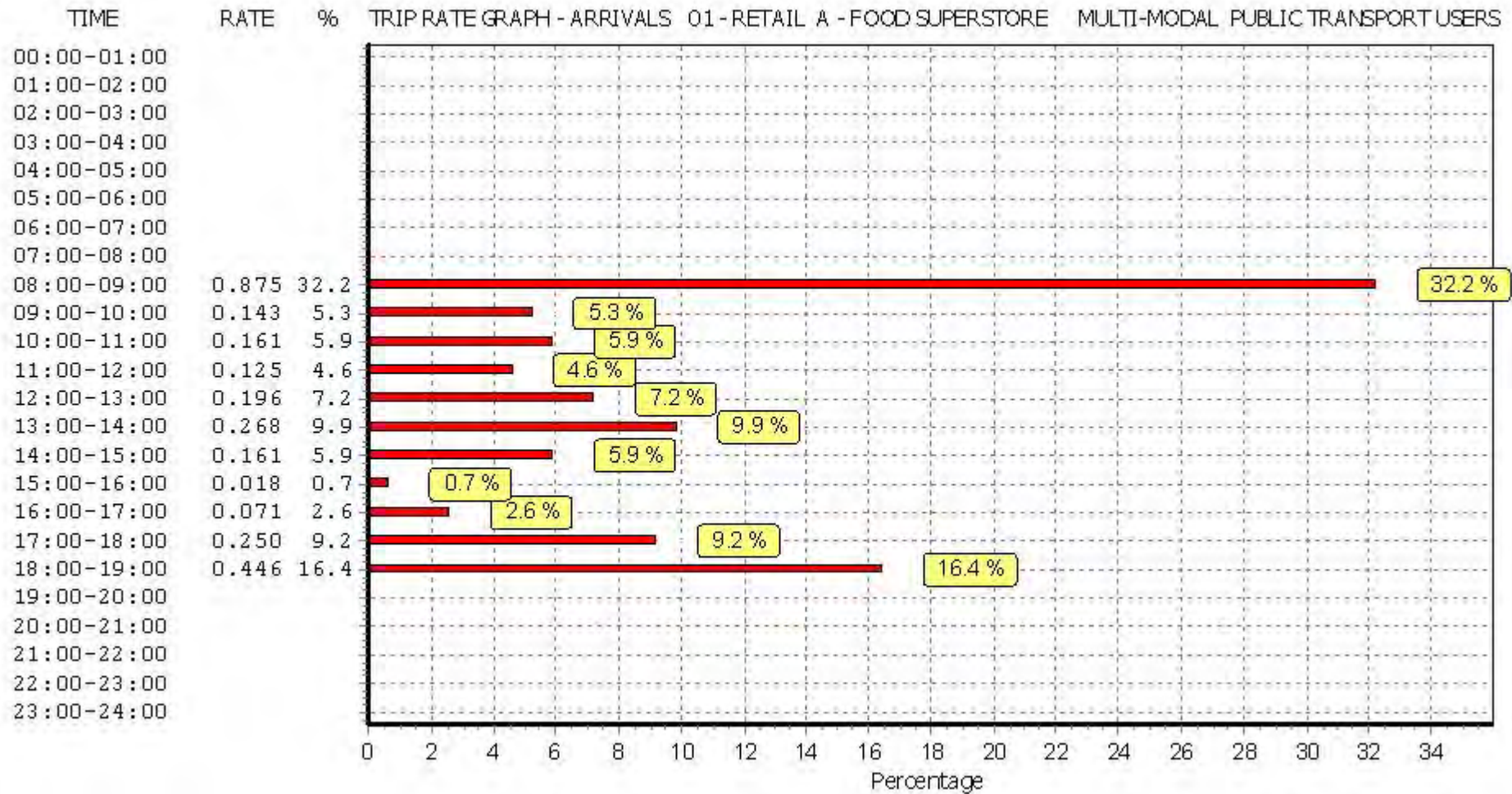

This graph is a visual representation of the trip rate calculation results screen. The same time periods and trip rates are displayed, but in addition there is an additional column showing the percentage of the total trip rate by individual time period, allowing peak periods to be easily identified through observation. Note that the type of count and the selected direction is shown at the top of the graph.

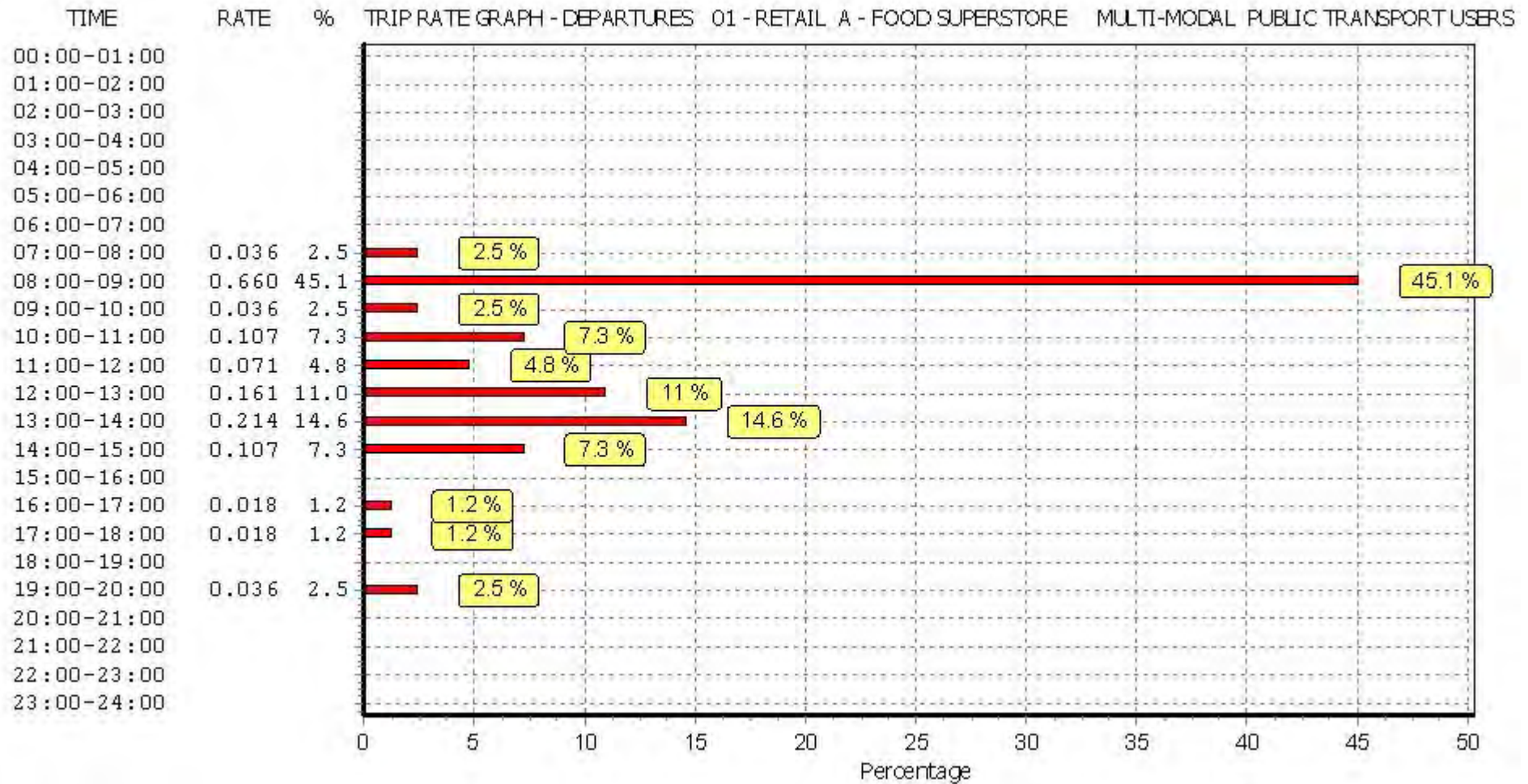

This graph is a visual representation of the trip rate calculation results screen. The same time periods and trip rates are displayed, but in addition there is an additional column showing the percentage of the total trip rate by individual time period, allowing peak periods to be easily identified through observation. Note that the type of count and the selected direction is shown at the top of the graph.

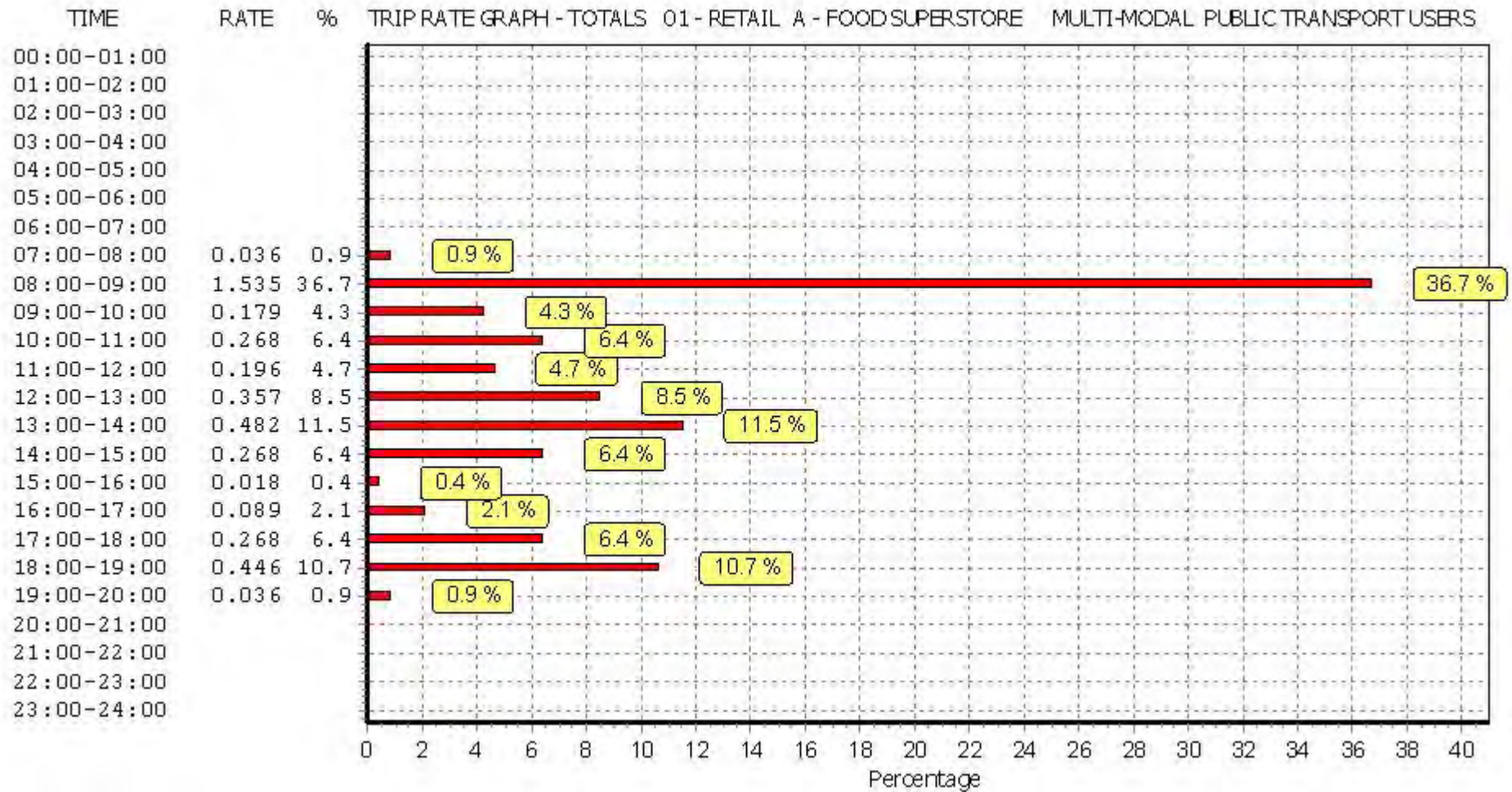

This graph is a visual representation of the trip rate calculation results screen. The same time periods and trip rates are displayed, but in addition there is an additional column showing the percentage of the total trip rate by individual time period, allowing peak periods to be easily identified through observation. Note that the type of count and the selected direction is shown at the top of the graph.

TRIP RATE for Land Use 01 - RETAIL/A - FOOD SUPERSTORE

MULTI-MODAL TOTAL PEOPLE

Calculation factor: 100 sqm

BOLD print indicates peak (busiest) period

Time Range	ARRIVALS			DEPARTURES			TOTALS		
	No. Days	Ave. GFA	Trip Rate	No. Days	Ave. GFA	Trip Rate	No. Days	Ave. GFA	Trip Rate
00:00 - 01:00									
01:00 - 02:00									
02:00 - 03:00									
03:00 - 04:00									
04:00 - 05:00									
05:00 - 06:00									
06:00 - 07:00									
07:00 - 08:00	3	1868	1.339	3	1868	0.892	3	1868	2.231
08:00 - 09:00	3	1868	7.318	3	1868	5.979	3	1868	13.297
09:00 - 10:00	3	1868	7.371	3	1868	5.729	3	1868	13.100
10:00 - 11:00	3	1868	9.316	3	1868	8.174	3	1868	17.490
11:00 - 12:00	3	1868	11.422	3	1868	10.780	3	1868	22.202
12:00 - 13:00	3	1868	12.190	3	1868	11.886	3	1868	24.076
13:00 - 14:00	3	1868	10.655	3	1868	11.208	3	1868	21.863
14:00 - 15:00	3	1868	10.780	3	1868	10.280	3	1868	21.060
15:00 - 16:00	3	1868	12.815	3	1868	13.332	3	1868	26.147
16:00 - 17:00	3	1868	14.314	3	1868	13.671	3	1868	27.985
17:00 - 18:00	3	1868	15.170	3	1868	16.759	3	1868	31.929
18:00 - 19:00	3	1868	11.940	3	1868	14.242	3	1868	26.182
19:00 - 20:00	3	1868	9.620	3	1868	10.798	3	1868	20.418
20:00 - 21:00	3	1868	8.299	3	1868	9.656	3	1868	17.955
21:00 - 22:00	3	1868	5.211	3	1868	6.729	3	1868	11.940
22:00 - 23:00	1	1487	0.269	1	1487	1.143	1	1487	1.412
23:00 - 24:00									
Total Rates:			148.029			151.258			299.287

This section displays the trip rate results based on the selected set of surveys and the selected count type (shown just above the table). It is split by three main columns, representing arrivals trips, departures trips, and total trips (arrivals plus departures). Within each of these main columns are three sub-columns. These display the number of survey days where count data is included (per time period), the average value of the selected trip rate calculation parameter (per time period), and the trip rate result (per time period). Total trip rates (the sum of the column) are also displayed at the foot of the table.

To obtain a trip rate, the average (mean) trip rate parameter value (TRP) is first calculated for all selected survey days that have count data available for the stated time period. The average (mean) number of arrivals, departures or totals (whichever applies) is also calculated (COUNT) for all selected survey days that have count data available for the stated time period. Then, the average count is divided by the average trip rate parameter value, and multiplied by the stated calculation factor (shown just above the table and abbreviated here as FACT). So, the method is: $COUNT/TRP*FACT$. Trip rates are then rounded to 3 decimal places.

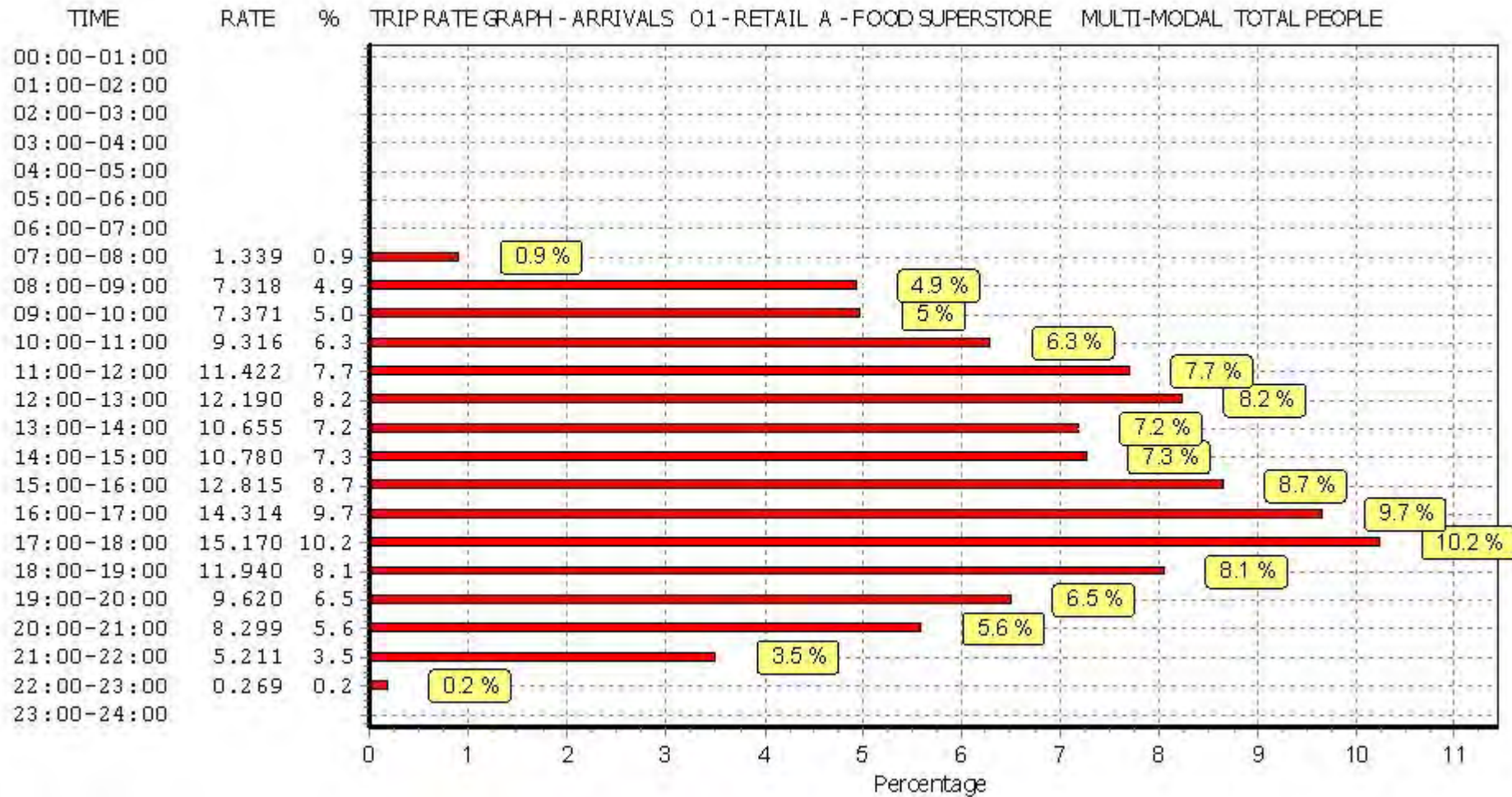

This graph is a visual representation of the trip rate calculation results screen. The same time periods and trip rates are displayed, but in addition there is an additional column showing the percentage of the total trip rate by individual time period, allowing peak periods to be easily identified through observation. Note that the type of count and the selected direction is shown at the top of the graph.

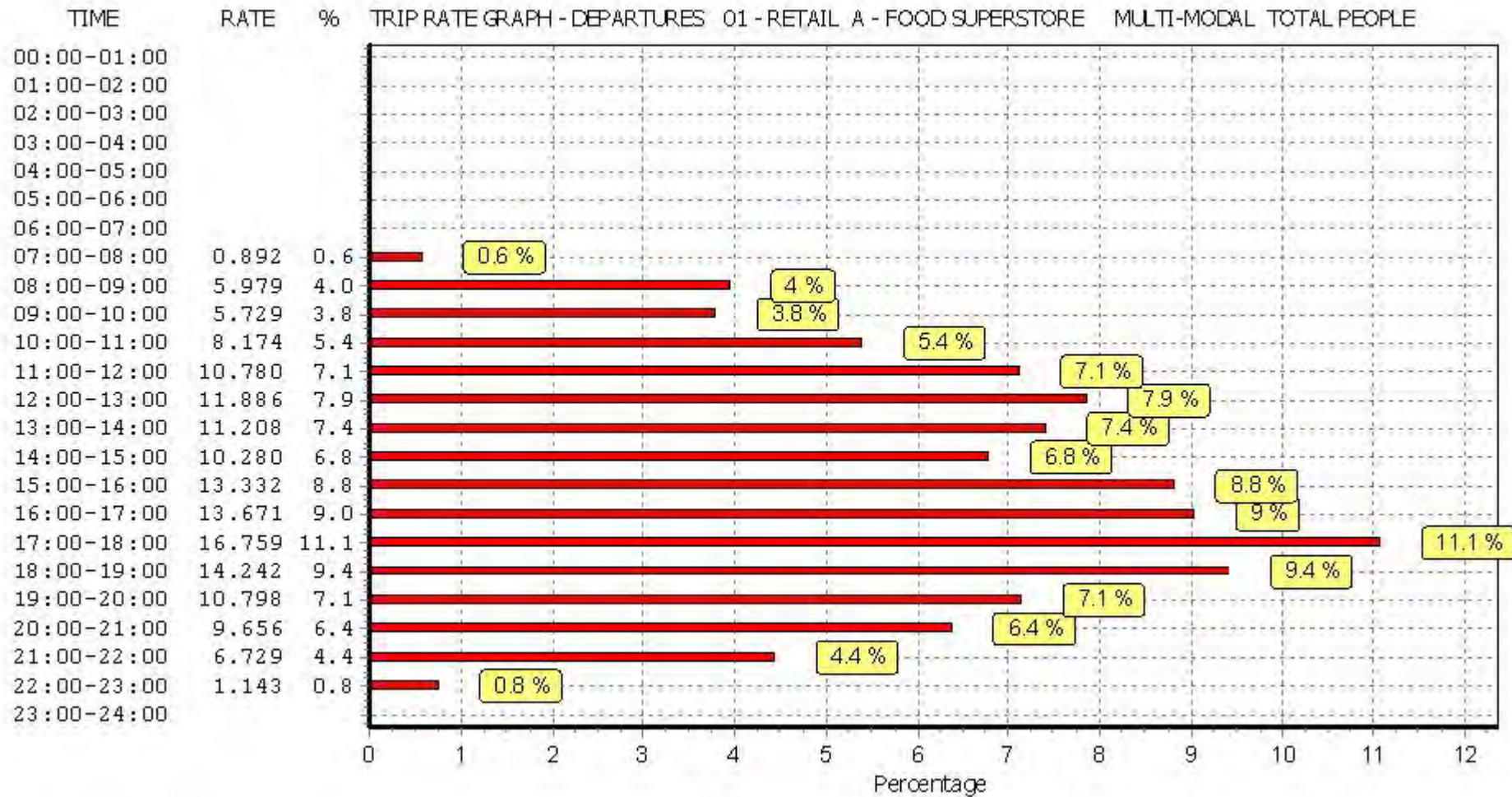

This graph is a visual representation of the trip rate calculation results screen. The same time periods and trip rates are displayed, but in addition there is an additional column showing the percentage of the total trip rate by individual time period, allowing peak periods to be easily identified through observation. Note that the type of count and the selected direction is shown at the top of the graph.

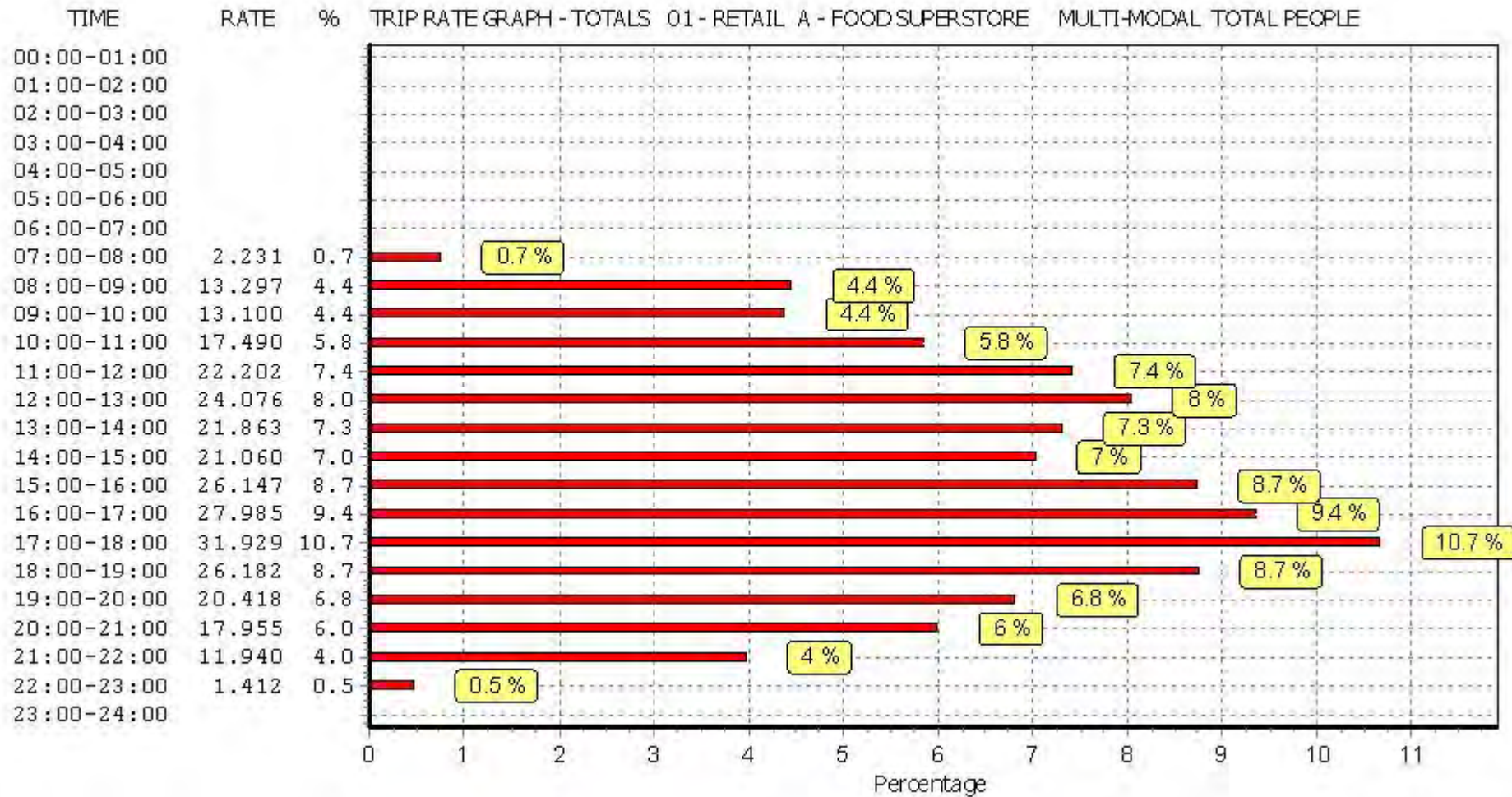

This graph is a visual representation of the trip rate calculation results screen. The same time periods and trip rates are displayed, but in addition there is an additional column showing the percentage of the total trip rate by individual time period, allowing peak periods to be easily identified through observation. Note that the type of count and the selected direction is shown at the top of the graph.

Calculation Reference: AUDIT-515501-190115-0117

TRIP RATE CALCULATION SELECTION PARAMETERS:

Land Use : 01 - RETAIL
 Category : A - FOOD SUPERSTORE
 MULTI-MODAL VEHICLES

Selected regions and areas:

07	YORKSHIRE & NORTH LINCOLNSHIRE	
	NY NORTH YORKSHIRE	1 days
09	NORTH	
	DH DURHAM	1 days
11	SCOTLAND	
	GC GLASGOW CITY	1 days
	HI HIGHLAND	1 days

This section displays the number of survey days per TRICS® sub-region in the selected set

Secondary Filtering selection:

This data displays the chosen trip rate parameter and its selected range. Only sites that fall within the parameter range are included in the trip rate calculation.

Parameter: Gross floor area
 Actual Range: 800 to 3480 (units: sqm)
 Range Selected by User: 800 to 4000 (units: sqm)

Parking Spaces Range: Selected: 0 to 833 Actual: 0 to 833

Public Transport Provision:

Selection by: Include all surveys

Date Range: 01/01/00 to 19/07/13

This data displays the range of survey dates selected. Only surveys that were conducted within this date range are included in the trip rate calculation.

Selected survey days:

Saturday 4 days

This data displays the number of selected surveys by day of the week.

Selected survey types:

Manual count 4 days
 Directional ATC Count 0 days

This data displays the number of manual classified surveys and the number of unclassified ATC surveys, the total adding up to the overall number of surveys in the selected set. Manual surveys are undertaken using staff, whilst ATC surveys are undertaken using machines.

Selected Locations:

Suburban Area (PPS6 Out of Centre) 4

This data displays the number of surveys per main location category within the selected set. The main location categories consist of Free Standing, Edge of Town, Suburban Area, Neighbourhood Centre, Edge of Town Centre, Town Centre and Not Known.

Selected Location Sub Categories:

Residential Zone 2
 Retail Zone 1
 No Sub Category 1

This data displays the number of surveys per location sub-category within the selected set. The location sub-categories consist of Commercial Zone, Industrial Zone, Development Zone, Residential Zone, Retail Zone, Built-Up Zone, Village, Out of Town, High Street and No Sub Category.

Secondary Filtering selection:

Use Class:

A1 4 days

This data displays the number of surveys per Use Class classification within the selected set. The Use Classes Order 2005 has been used for this purpose, which can be found within the Library module of TRICS®.

Secondary Filtering selection (Cont.):

Population within 1 mile:

1,001 to 5,000	1 days
10,001 to 15,000	1 days
20,001 to 25,000	1 days
25,001 to 50,000	1 days

This data displays the number of selected surveys within stated 1-mile radii of population.

Population within 5 miles:

25,001 to 50,000	1 days
50,001 to 75,000	1 days
75,001 to 100,000	1 days
500,001 or More	1 days

This data displays the number of selected surveys within stated 5-mile radii of population.

Car ownership within 5 miles:

0.6 to 1.0	1 days
1.1 to 1.5	2 days
1.6 to 2.0	1 days

This data displays the number of selected surveys within stated ranges of average cars owned per residential dwelling, within a radius of 5-miles of selected survey sites.

Petrol filling station:

PFS is present at the site and is included in the count	0 days
PFS is present at the site but is excluded from the count	0 days
There is no PFS at the site	4 days

This data displays the number of surveys within the selected set that include petrol filling station activity, and the number of surveys that do not.

Travel Plan:

No	4 days
----	--------

This data displays the number of surveys within the selected set that were undertaken at sites with Travel Plans in place, and the number of surveys that were undertaken at sites without Travel Plans.

PTAL Rating:

No PTAL Present	4 days
-----------------	--------

This data displays the number of selected surveys with PTAL Ratings.

LIST OF SITES relevant to selection parameters

1	DH-01-A-02 SAI NSBURY'S SUNDERLAND ROAD DURHAM GILESGATE Suburban Area (PPS6 Out of Centre) Residential Zone Total Gross floor area: 800 sqm <i>Survey date: SATURDAY 25/10/08</i>	DURHAM <i>Survey Type: MANUAL</i>
2	GC-01-A-04 MORRI SONS TITWOOD ROAD GLASGOW CROSSMYLOOF Suburban Area (PPS6 Out of Centre) Residential Zone Total Gross floor area: 2500 sqm <i>Survey date: SATURDAY 07/06/08</i>	GLASGOW CITY <i>Survey Type: MANUAL</i>
3	HI-01-A-01 CO-OPERATIVE 74 TELFORD STREET INVERNESS MERKINCH Suburban Area (PPS6 Out of Centre) Retail Zone Total Gross floor area: 3480 sqm <i>Survey date: SATURDAY 14/05/11</i>	HIGH LAND <i>Survey Type: MANUAL</i>
4	NY-01-A-05 SAI NSBURY'S HIGH STREET NORTHALLERTON Suburban Area (PPS6 Out of Centre) No Sub Category Total Gross floor area: 2300 sqm <i>Survey date: SATURDAY 26/09/09</i>	NORTH YORKSHIRE <i>Survey Type: MANUAL</i>

This section provides a list of all survey sites and days in the selected set. For each individual survey site, it displays a unique site reference code and site address, the selected trip rate calculation parameter and its value, the day of the week and date of each survey, and whether the survey was a manual classified count or an ATC count.

TRIP RATE for Land Use 01 - RETAIL/A - FOOD SUPERSTORE

MULTI-MODAL VEHICLES

Calculation factor: 100 sqm

BOLD print indicates peak (busiest) period

Time Range	ARRIVALS			DEPARTURES			TOTALS		
	No. Days	Ave. GFA	Trip Rate	No. Days	Ave. GFA	Trip Rate	No. Days	Ave. GFA	Trip Rate
00:00 - 01:00									
01:00 - 02:00									
02:00 - 03:00									
03:00 - 04:00									
04:00 - 05:00									
05:00 - 06:00									
06:00 - 07:00									
07:00 - 08:00	4	2270	0.815	4	2270	0.507	4	2270	1.322
08:00 - 09:00	4	2270	2.577	4	2270	1.927	4	2270	4.504
09:00 - 10:00	4	2270	4.383	4	2270	3.546	4	2270	7.929
10:00 - 11:00	4	2270	4.747	4	2270	4.857	4	2270	9.604
11:00 - 12:00	4	2270	5.430	4	2270	5.154	4	2270	10.584
12:00 - 13:00	4	2270	5.033	4	2270	5.176	4	2270	10.209
13:00 - 14:00	4	2270	5.661	4	2270	5.154	4	2270	10.815
14:00 - 15:00	4	2270	5.385	4	2270	5.242	4	2270	10.627
15:00 - 16:00	4	2270	5.562	4	2270	5.022	4	2270	10.584
16:00 - 17:00	4	2270	5.881	4	2270	5.220	4	2270	11.101
17:00 - 18:00	4	2270	4.141	4	2270	5.496	4	2270	9.637
18:00 - 19:00	4	2270	3.987	4	2270	4.725	4	2270	8.712
19:00 - 20:00	4	2270	2.643	4	2270	3.667	4	2270	6.310
20:00 - 21:00	4	2270	1.156	4	2270	1.487	4	2270	2.643
21:00 - 22:00	4	2270	0.551	4	2270	0.771	4	2270	1.322
22:00 - 23:00	1	2300	0.043	1	2300	0.130	1	2300	0.173
23:00 - 24:00									
Total Rates:			57.995			58.081			116.076

This section displays the trip rate results based on the selected set of surveys and the selected count type (shown just above the table). It is split by three main columns, representing arrivals trips, departures trips, and total trips (arrivals plus departures). Within each of these main columns are three sub-columns. These display the number of survey days where count data is included (per time period), the average value of the selected trip rate calculation parameter (per time period), and the trip rate result (per time period). Total trip rates (the sum of the column) are also displayed at the foot of the table.

To obtain a trip rate, the average (mean) trip rate parameter value (TRP) is first calculated for all selected survey days that have count data available for the stated time period. The average (mean) number of arrivals, departures or totals (whichever applies) is also calculated (COUNT) for all selected survey days that have count data available for the stated time period. Then, the average count is divided by the average trip rate parameter value, and multiplied by the stated calculation factor (shown just above the table and abbreviated here as FACT). So, the method is: $COUNT/TRP*FACT$. Trip rates are then rounded to 3 decimal places.

The survey data, graphs and all associated supporting information, contained within the TRICS Database are published by TRICS Consortium Limited ("the Company") and the Company claims copyright and database rights in this published work. The Company authorises those who possess a current TRICS licence to access the TRICS Database and copy the data contained within the TRICS Database for the licence holders' use only. Any resulting copy must retain all copyrights and other proprietary notices, and any disclaimer contained thereon.

The Company accepts no responsibility for loss which may arise from reliance on data contained in the TRICS Database. [No warranty of any kind, express or implied, is made as to the data contained in the TRICS Database.]

Parameter summary

Trip rate parameter range selected:	800 - 3480 (units: sqm)
Survey date date range:	01/01/00 - 19/07/13
Number of weekdays (Monday-Friday):	0
Number of Saturdays:	4
Number of Sundays:	0
Surveys automatically removed from selection:	1
Surveys manually removed from selection:	0

This section displays a quick summary of some of the data filtering selections made by the TRICS® user. The trip rate calculation parameter range of all selected surveys is displayed first, followed by the range of minimum and maximum survey dates selected by the user. Then, the total number of selected weekdays and weekend days in the selected set of surveys are show. Finally, the number of survey days that have been manually removed from the selected set outside of the standard filtering procedure are displayed.

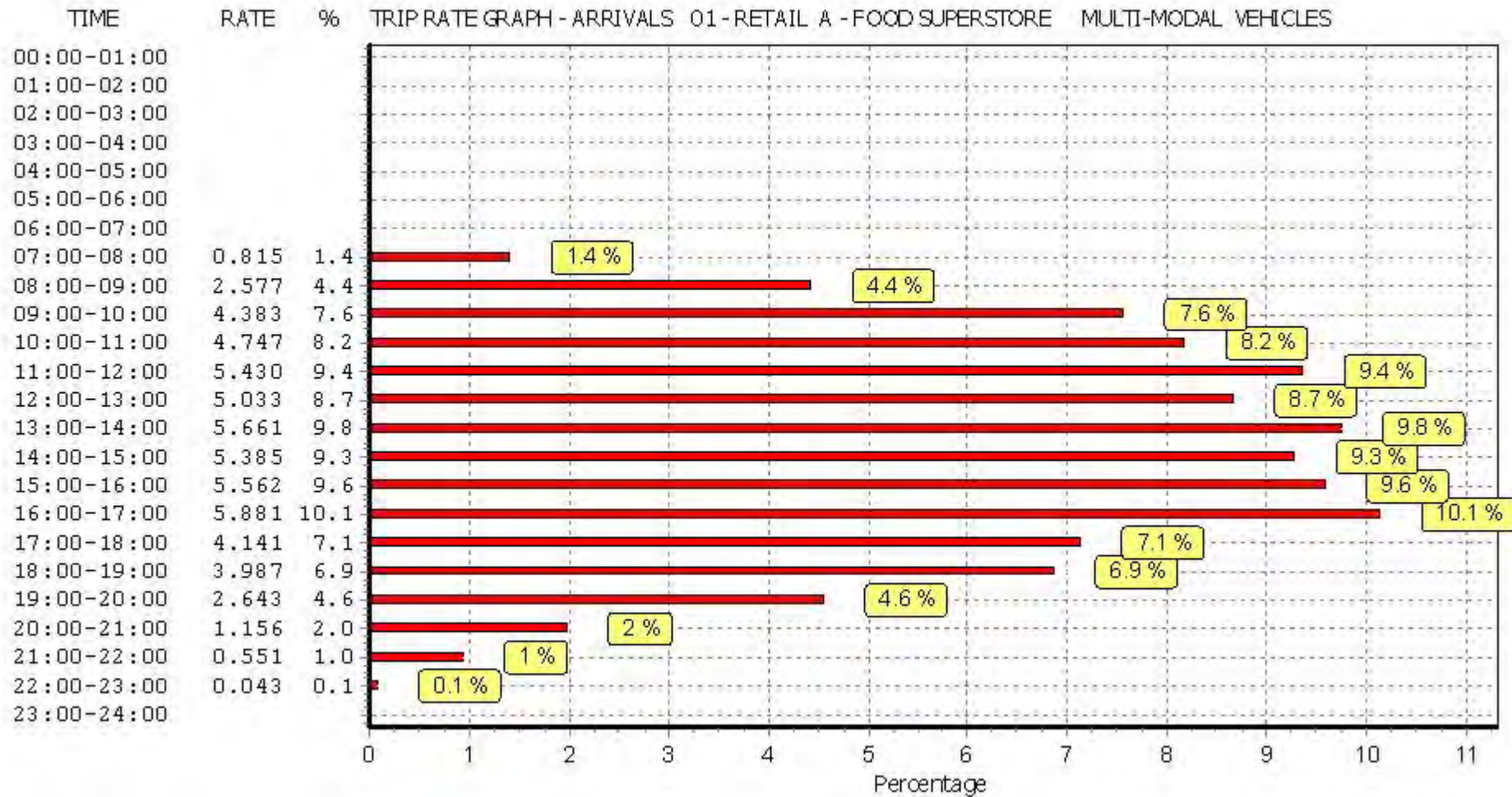

This graph is a visual representation of the trip rate calculation results screen. The same time periods and trip rates are displayed, but in addition there is an additional column showing the percentage of the total trip rate by individual time period, allowing peak periods to be easily identified through observation. Note that the type of count and the selected direction is shown at the top of the graph.

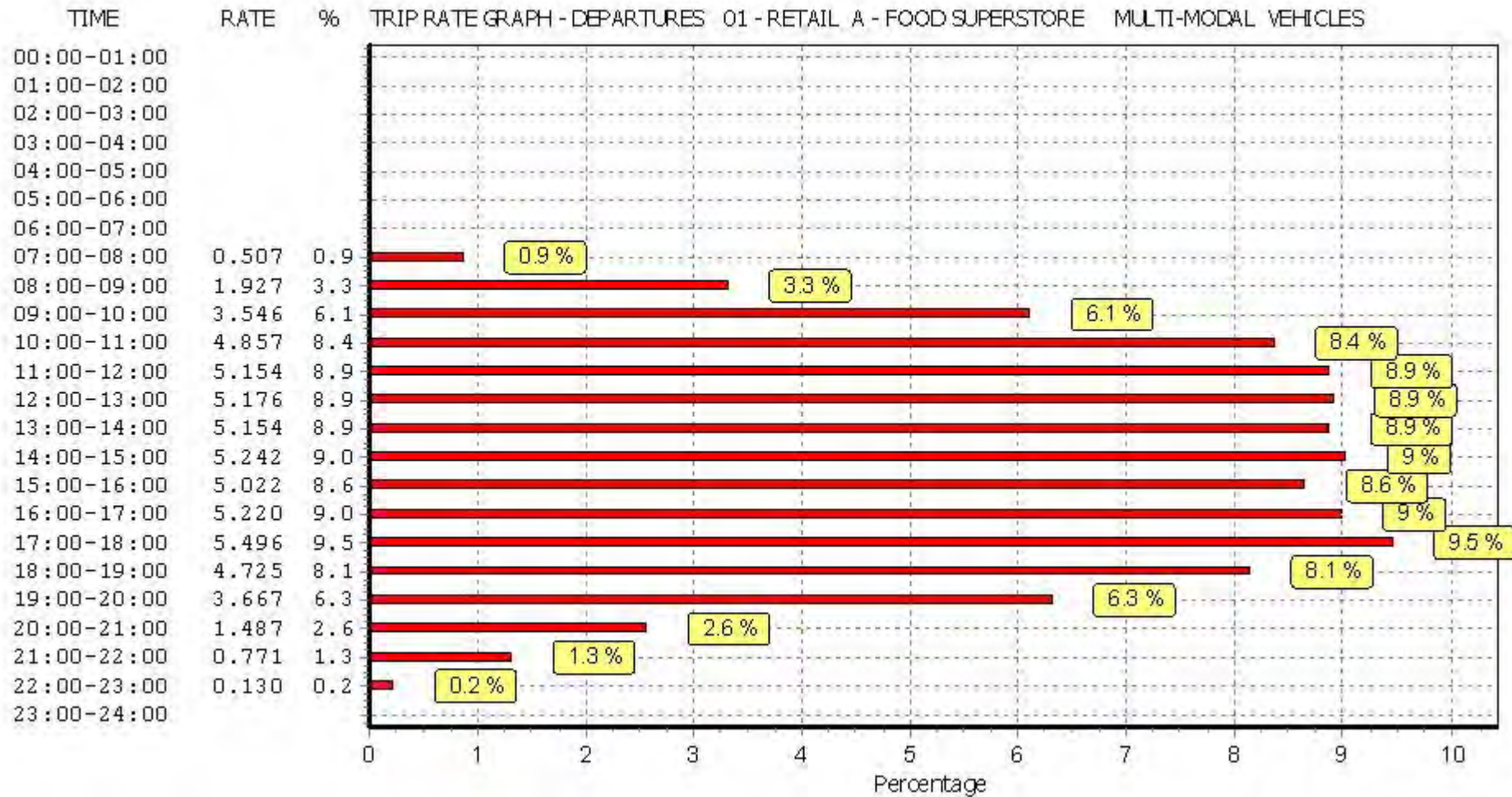

This graph is a visual representation of the trip rate calculation results screen. The same time periods and trip rates are displayed, but in addition there is an additional column showing the percentage of the total trip rate by individual time period, allowing peak periods to be easily identified through observation. Note that the type of count and the selected direction is shown at the top of the graph.

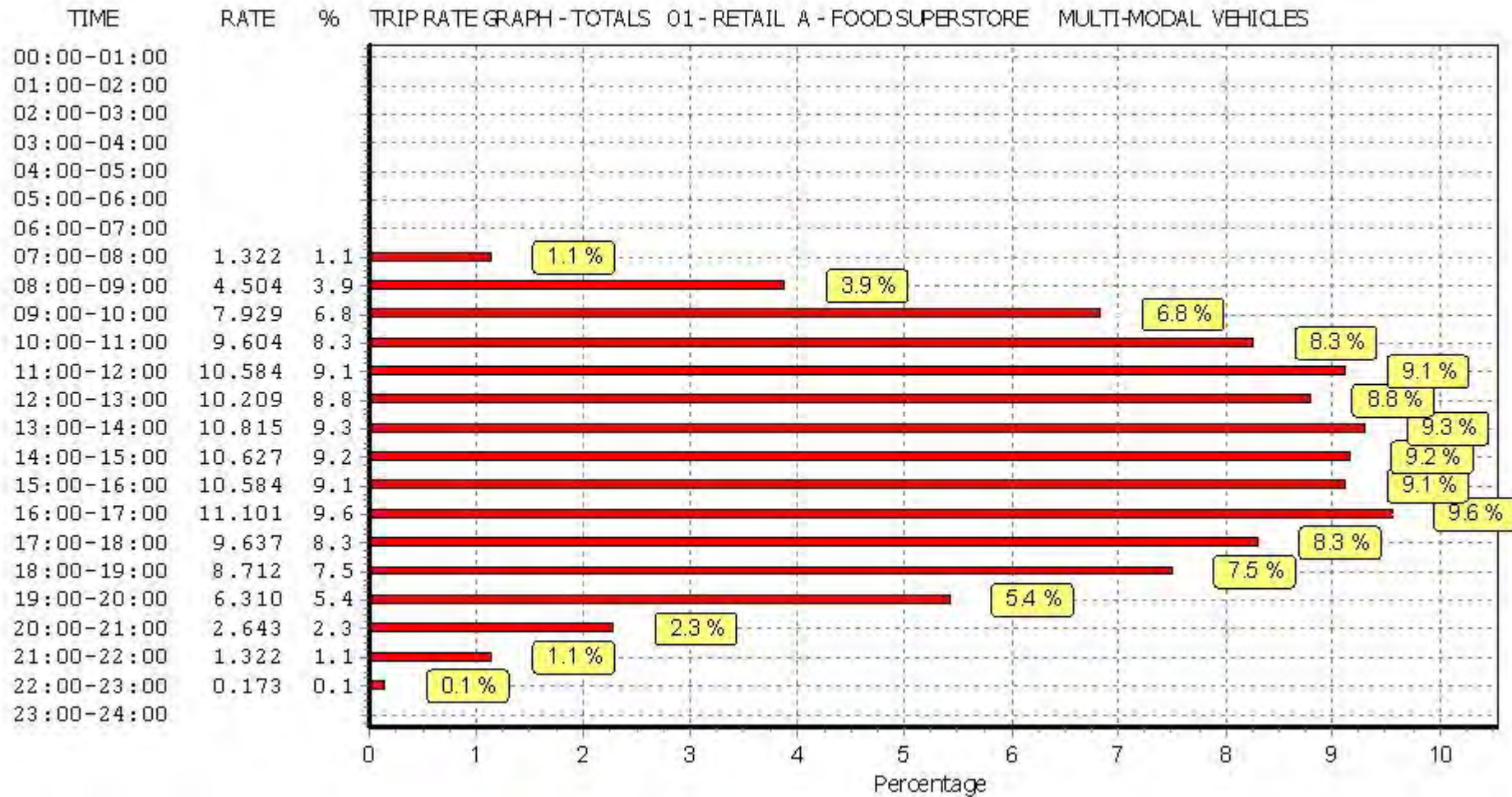

This graph is a visual representation of the trip rate calculation results screen. The same time periods and trip rates are displayed, but in addition there is an additional column showing the percentage of the total trip rate by individual time period, allowing peak periods to be easily identified through observation. Note that the type of count and the selected direction is shown at the top of the graph.

TRIP RATE for Land Use 01 - RETAIL/A - FOOD SUPERSTORE

MULTI-MODAL TAXIS

Calculation factor: 100 sqm

BOLD print indicates peak (busiest) period

Time Range	ARRIVALS			DEPARTURES			TOTALS		
	No. Days	Ave. GFA	Trip Rate	No. Days	Ave. GFA	Trip Rate	No. Days	Ave. GFA	Trip Rate
00:00 - 01:00									
01:00 - 02:00									
02:00 - 03:00									
03:00 - 04:00									
04:00 - 05:00									
05:00 - 06:00									
06:00 - 07:00									
07:00 - 08:00	4	2270	0.000	4	2270	0.000	4	2270	0.000
08:00 - 09:00	4	2270	0.022	4	2270	0.011	4	2270	0.033
09:00 - 10:00	4	2270	0.011	4	2270	0.022	4	2270	0.033
10:00 - 11:00	4	2270	0.066	4	2270	0.033	4	2270	0.099
11:00 - 12:00	4	2270	0.055	4	2270	0.044	4	2270	0.099
12:00 - 13:00	4	2270	0.055	4	2270	0.066	4	2270	0.121
13:00 - 14:00	4	2270	0.110	4	2270	0.044	4	2270	0.154
14:00 - 15:00	4	2270	0.110	4	2270	0.154	4	2270	0.264
15:00 - 16:00	4	2270	0.044	4	2270	0.055	4	2270	0.099
16:00 - 17:00	4	2270	0.055	4	2270	0.066	4	2270	0.121
17:00 - 18:00	4	2270	0.055	4	2270	0.055	4	2270	0.110
18:00 - 19:00	4	2270	0.022	4	2270	0.033	4	2270	0.055
19:00 - 20:00	4	2270	0.022	4	2270	0.044	4	2270	0.066
20:00 - 21:00	4	2270	0.011	4	2270	0.011	4	2270	0.022
21:00 - 22:00	4	2270	0.000	4	2270	0.000	4	2270	0.000
22:00 - 23:00	1	2300	0.043	1	2300	0.043	1	2300	0.086
23:00 - 24:00									
Total Rates:			0.681			0.681			1.362

This section displays the trip rate results based on the selected set of surveys and the selected count type (shown just above the table). It is split by three main columns, representing arrivals trips, departures trips, and total trips (arrivals plus departures). Within each of these main columns are three sub-columns. These display the number of survey days where count data is included (per time period), the average value of the selected trip rate calculation parameter (per time period), and the trip rate result (per time period). Total trip rates (the sum of the column) are also displayed at the foot of the table.

To obtain a trip rate, the average (mean) trip rate parameter value (TRP) is first calculated for all selected survey days that have count data available for the stated time period. The average (mean) number of arrivals, departures or totals (whichever applies) is also calculated (COUNT) for all selected survey days that have count data available for the stated time period. Then, the average count is divided by the average trip rate parameter value, and multiplied by the stated calculation factor (shown just above the table and abbreviated here as FACT). So, the method is: $COUNT/TRP*FACT$. Trip rates are then rounded to 3 decimal places.

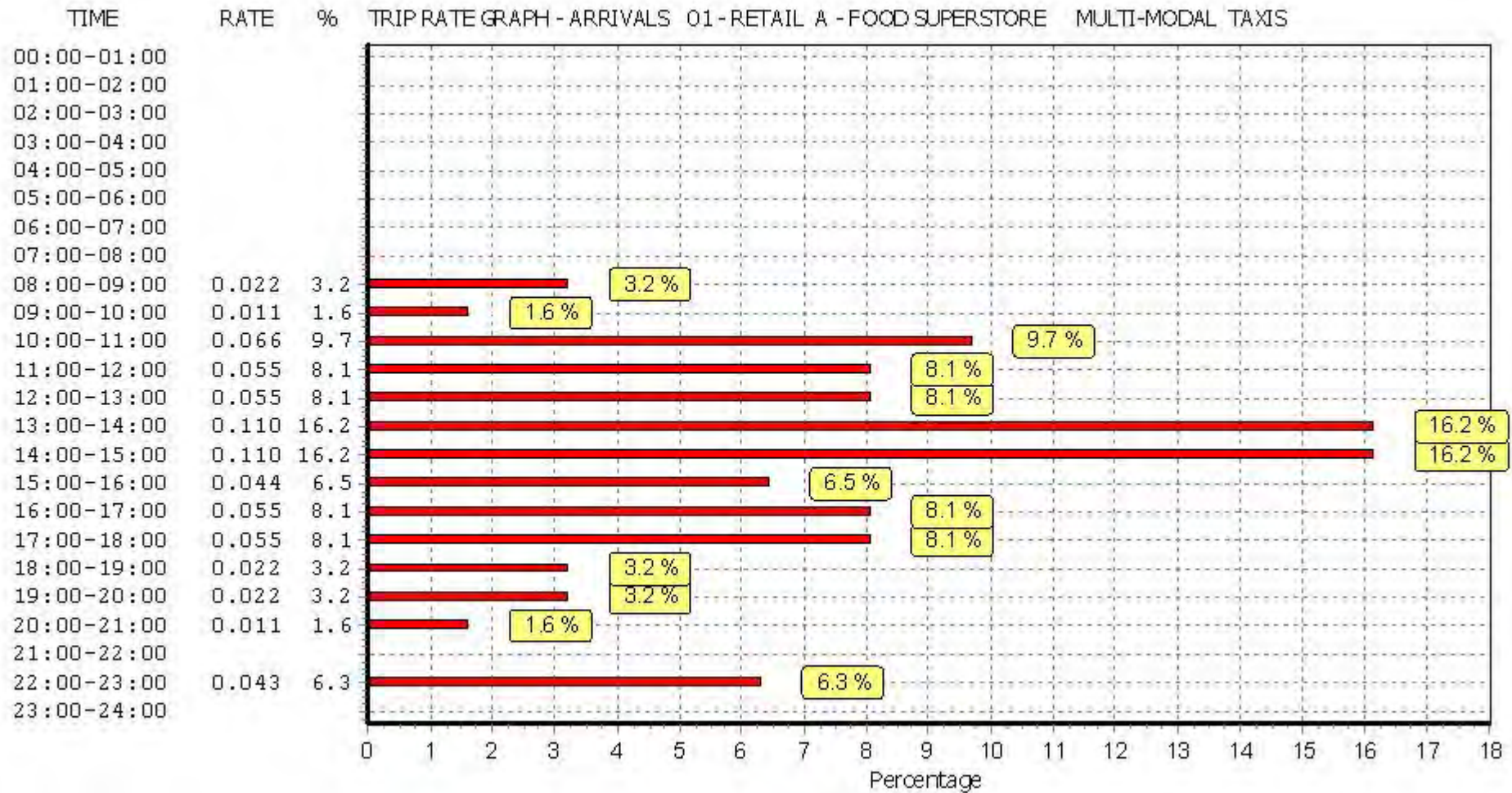

This graph is a visual representation of the trip rate calculation results screen. The same time periods and trip rates are displayed, but in addition there is an additional column showing the percentage of the total trip rate by individual time period, allowing peak periods to be easily identified through observation. Note that the type of count and the selected direction is shown at the top of the graph.

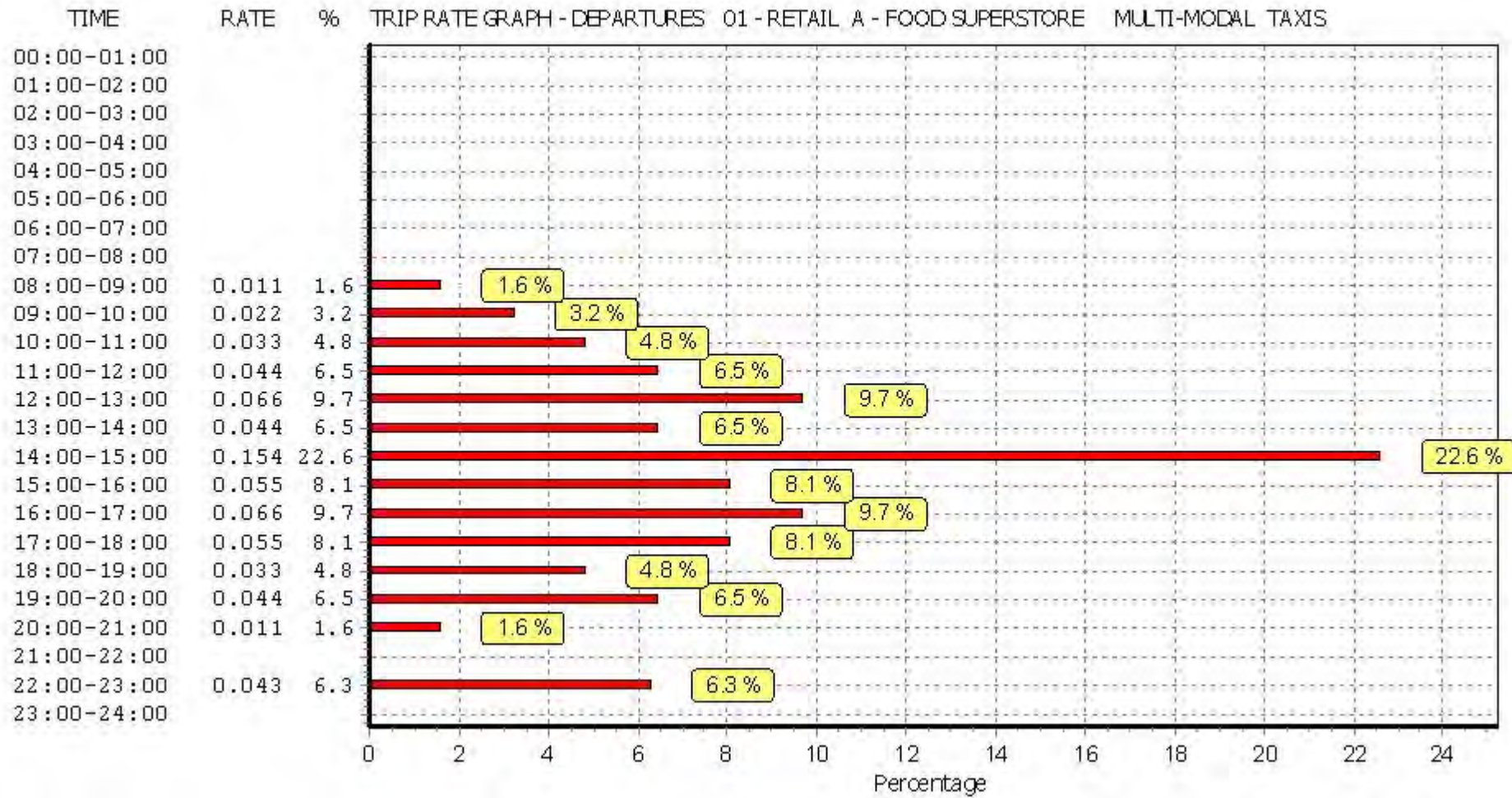

This graph is a visual representation of the trip rate calculation results screen. The same time periods and trip rates are displayed, but in addition there is an additional column showing the percentage of the total trip rate by individual time period, allowing peak periods to be easily identified through observation. Note that the type of count and the selected direction is shown at the top of the graph.

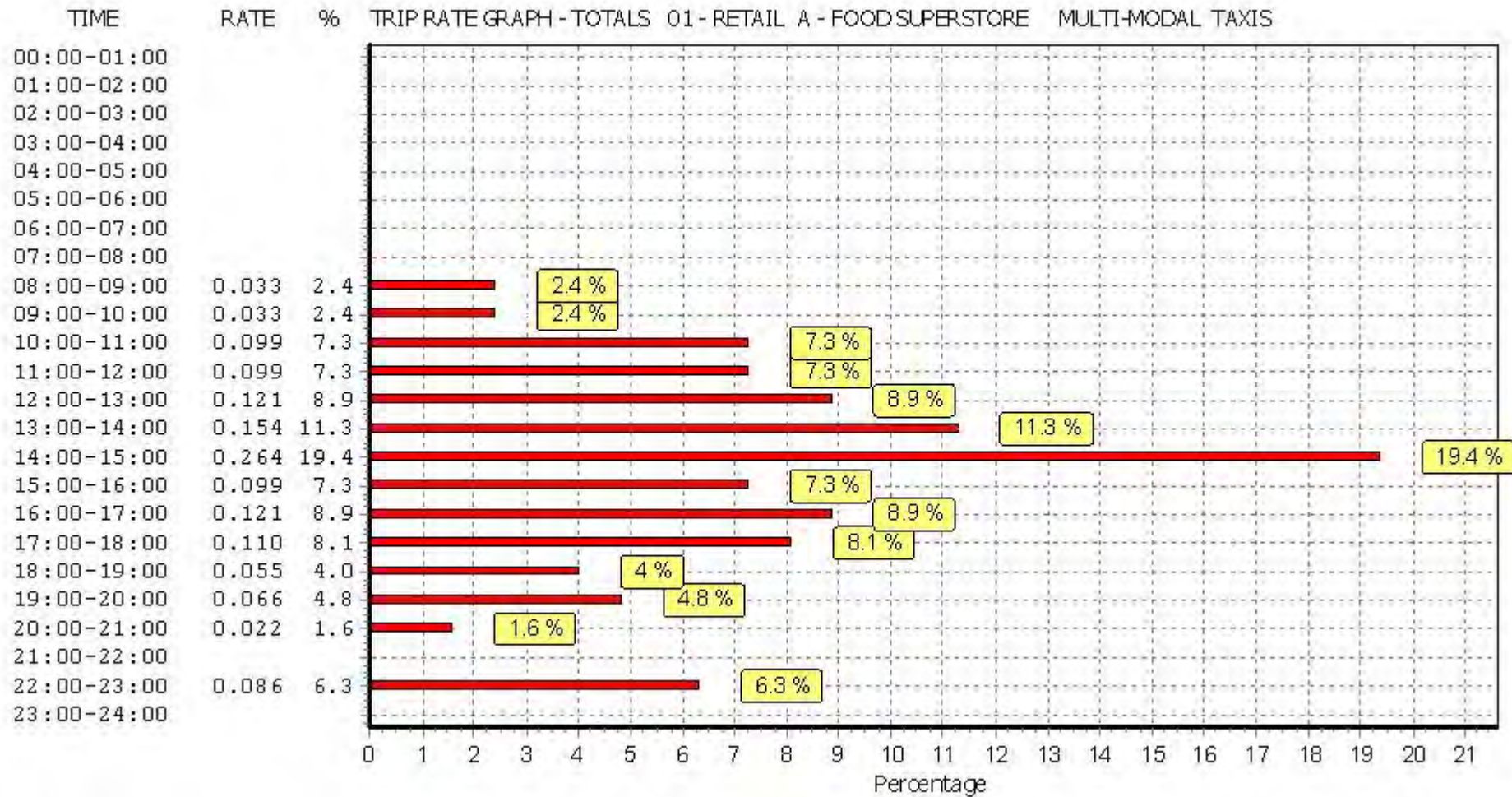

This graph is a visual representation of the trip rate calculation results screen. The same time periods and trip rates are displayed, but in addition there is an additional column showing the percentage of the total trip rate by individual time period, allowing peak periods to be easily identified through observation. Note that the type of count and the selected direction is shown at the top of the graph.

TRIP RATE for Land Use 01 - RETAIL/A - FOOD SUPERSTORE

MULTI-MODAL OGVS

Calculation factor: 100 sqm

BOLD print indicates peak (busiest) period

Time Range	ARRIVALS			DEPARTURES			TOTALS		
	No. Days	Ave. GFA	Trip Rate	No. Days	Ave. GFA	Trip Rate	No. Days	Ave. GFA	Trip Rate
00:00 - 01:00									
01:00 - 02:00									
02:00 - 03:00									
03:00 - 04:00									
04:00 - 05:00									
05:00 - 06:00									
06:00 - 07:00									
07:00 - 08:00	4	2270	0.099	4	2270	0.066	4	2270	0.165
08:00 - 09:00	4	2270	0.033	4	2270	0.066	4	2270	0.099
09:00 - 10:00	4	2270	0.022	4	2270	0.011	4	2270	0.033
10:00 - 11:00	4	2270	0.011	4	2270	0.011	4	2270	0.022
11:00 - 12:00	4	2270	0.011	4	2270	0.011	4	2270	0.022
12:00 - 13:00	4	2270	0.011	4	2270	0.000	4	2270	0.011
13:00 - 14:00	4	2270	0.011	4	2270	0.044	4	2270	0.055
14:00 - 15:00	4	2270	0.000	4	2270	0.000	4	2270	0.000
15:00 - 16:00	4	2270	0.033	4	2270	0.000	4	2270	0.033
16:00 - 17:00	4	2270	0.000	4	2270	0.011	4	2270	0.011
17:00 - 18:00	4	2270	0.000	4	2270	0.022	4	2270	0.022
18:00 - 19:00	4	2270	0.022	4	2270	0.011	4	2270	0.033
19:00 - 20:00	4	2270	0.022	4	2270	0.022	4	2270	0.044
20:00 - 21:00	4	2270	0.000	4	2270	0.000	4	2270	0.000
21:00 - 22:00	4	2270	0.000	4	2270	0.000	4	2270	0.000
22:00 - 23:00	1	2300	0.000	1	2300	0.000	1	2300	0.000
23:00 - 24:00									
Total Rates:			0.275			0.275			0.550

This section displays the trip rate results based on the selected set of surveys and the selected count type (shown just above the table). It is split by three main columns, representing arrivals trips, departures trips, and total trips (arrivals plus departures). Within each of these main columns are three sub-columns. These display the number of survey days where count data is included (per time period), the average value of the selected trip rate calculation parameter (per time period), and the trip rate result (per time period). Total trip rates (the sum of the column) are also displayed at the foot of the table.

To obtain a trip rate, the average (mean) trip rate parameter value (TRP) is first calculated for all selected survey days that have count data available for the stated time period. The average (mean) number of arrivals, departures or totals (whichever applies) is also calculated (COUNT) for all selected survey days that have count data available for the stated time period. Then, the average count is divided by the average trip rate parameter value, and multiplied by the stated calculation factor (shown just above the table and abbreviated here as FACT). So, the method is: $COUNT/TRP*FACT$. Trip rates are then rounded to 3 decimal places.

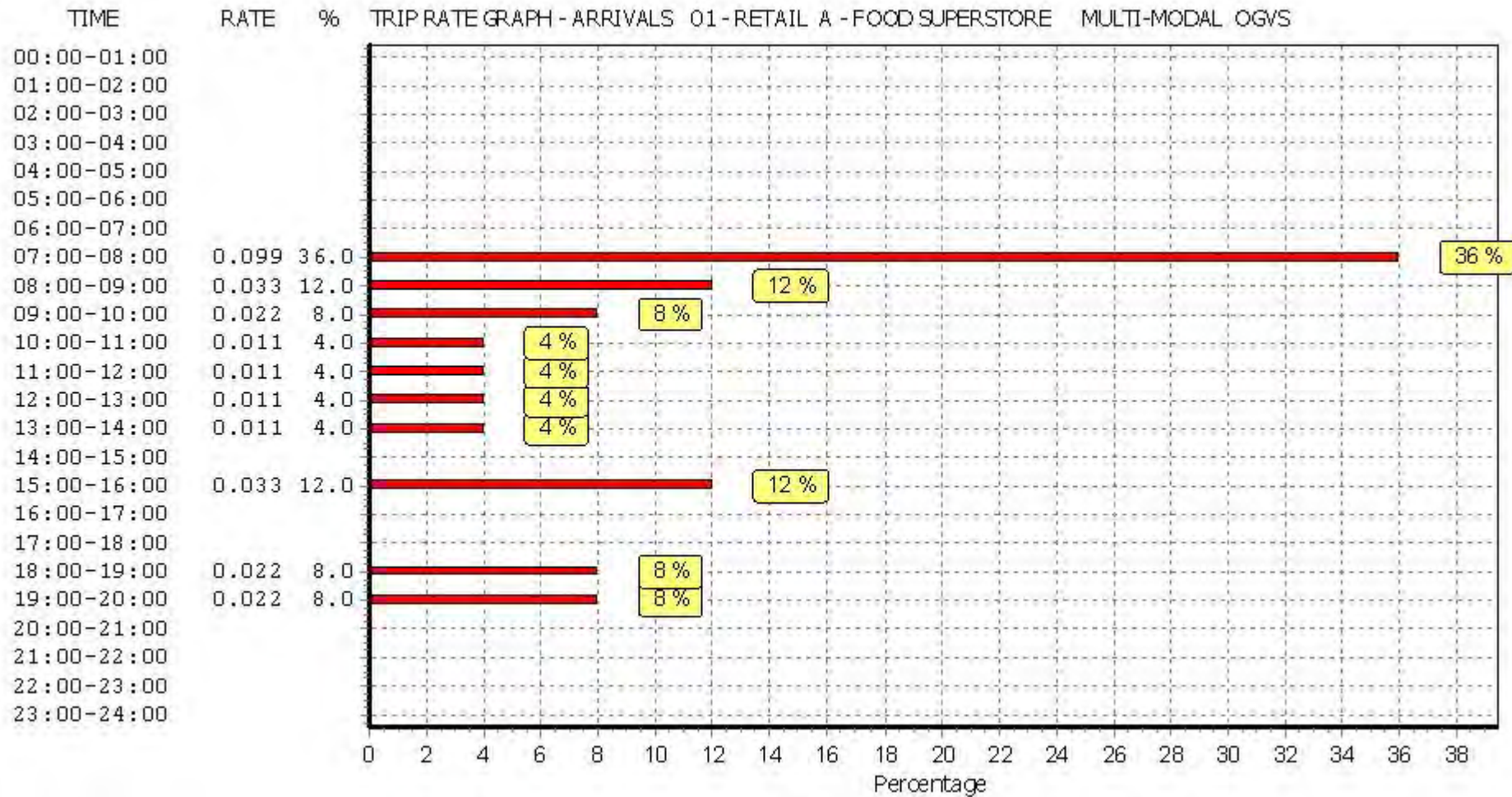

This graph is a visual representation of the trip rate calculation results screen. The same time periods and trip rates are displayed, but in addition there is an additional column showing the percentage of the total trip rate by individual time period, allowing peak periods to be easily identified through observation. Note that the type of count and the selected direction is shown at the top of the graph.

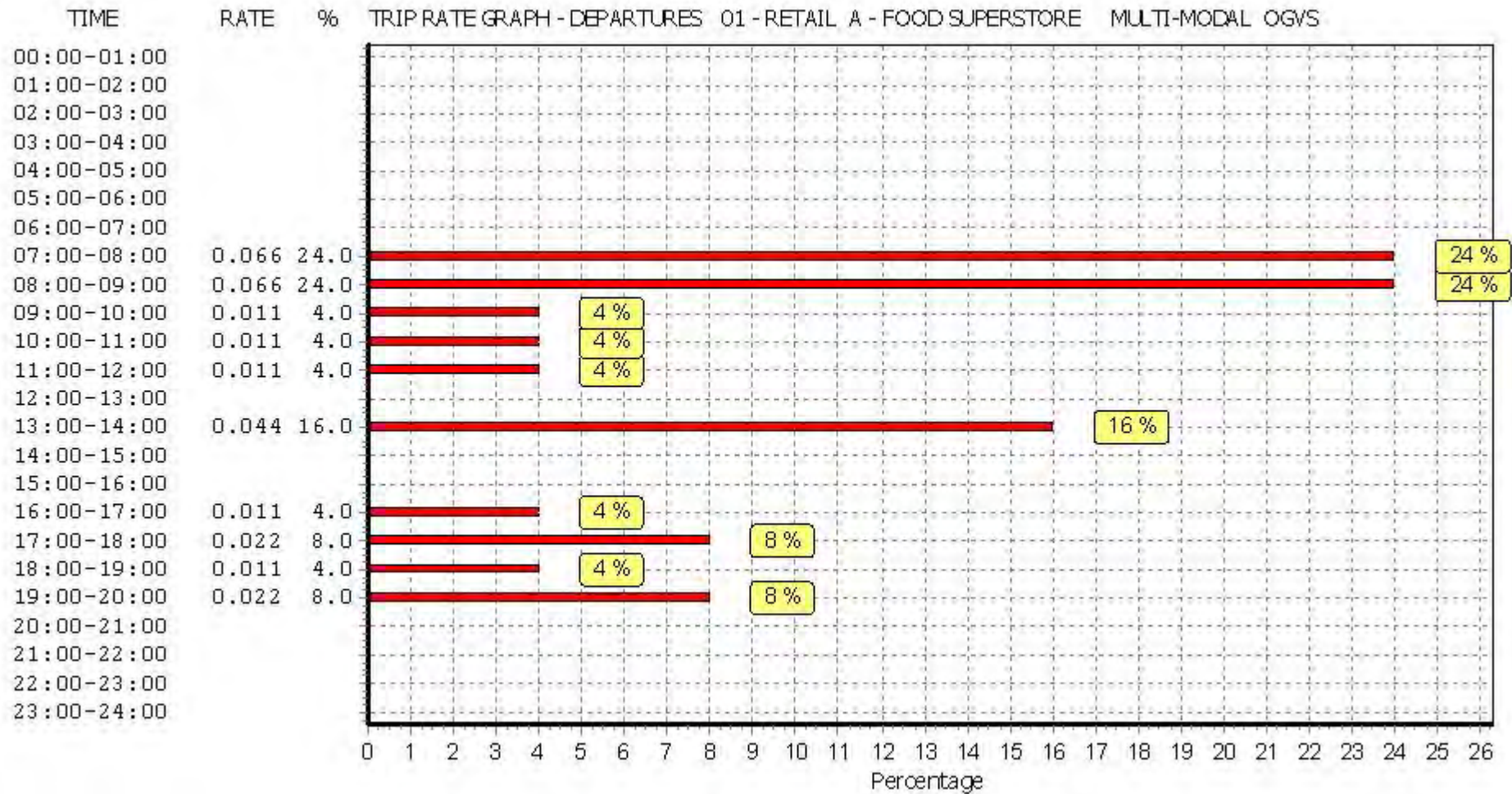

This graph is a visual representation of the trip rate calculation results screen. The same time periods and trip rates are displayed, but in addition there is an additional column showing the percentage of the total trip rate by individual time period, allowing peak periods to be easily identified through observation. Note that the type of count and the selected direction is shown at the top of the graph.

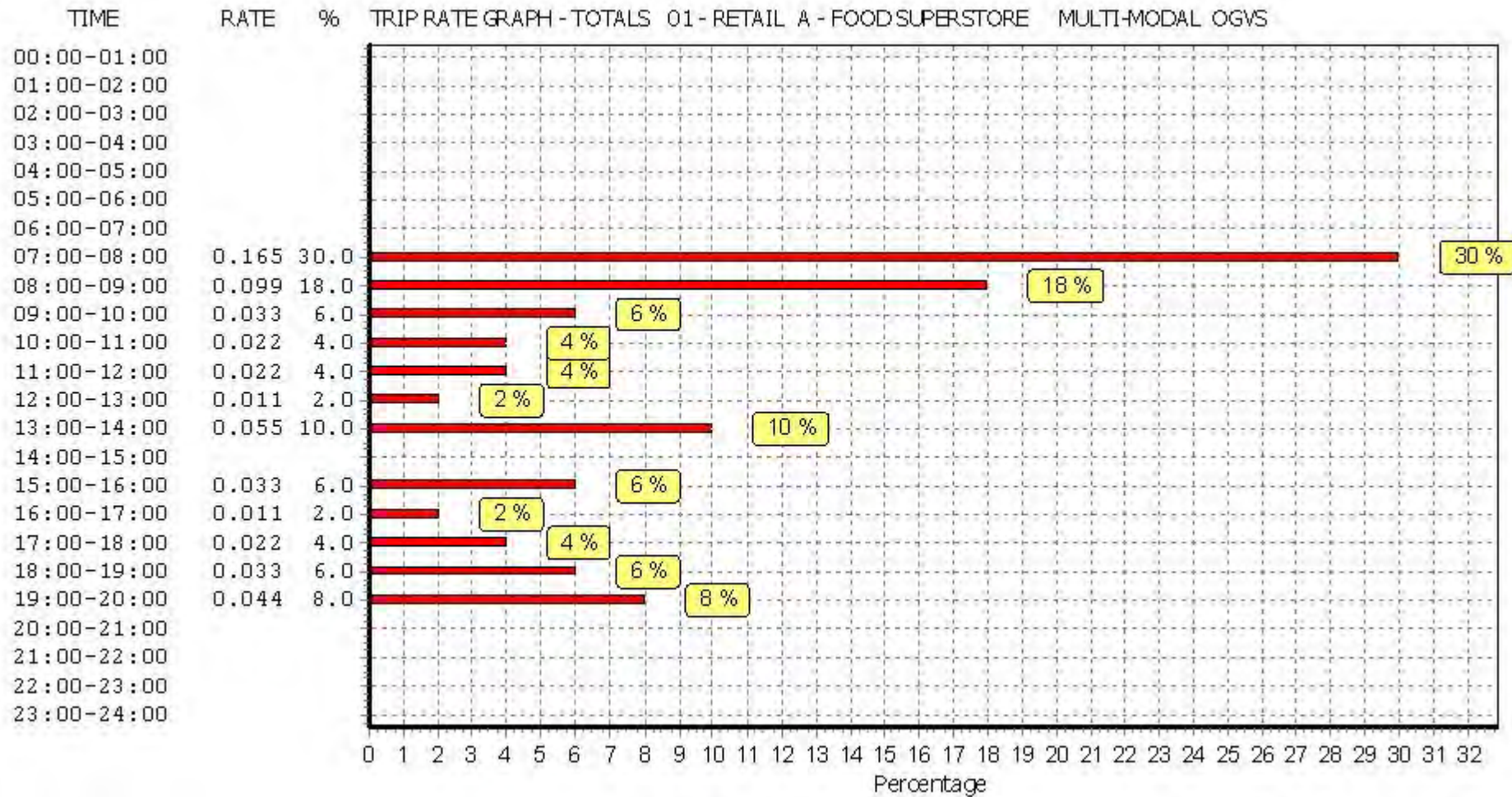

This graph is a visual representation of the trip rate calculation results screen. The same time periods and trip rates are displayed, but in addition there is an additional column showing the percentage of the total trip rate by individual time period, allowing peak periods to be easily identified through observation. Note that the type of count and the selected direction is shown at the top of the graph.

TRIP RATE for Land Use 01 - RETAIL/A - FOOD SUPERSTORE

MULTI-MODAL CYCLISTS

Calculation factor: 100 sqm

BOLD print indicates peak (busiest) period

Time Range	ARRIVALS			DEPARTURES			TOTALS		
	No. Days	Ave. GFA	Trip Rate	No. Days	Ave. GFA	Trip Rate	No. Days	Ave. GFA	Trip Rate
00:00 - 01:00									
01:00 - 02:00									
02:00 - 03:00									
03:00 - 04:00									
04:00 - 05:00									
05:00 - 06:00									
06:00 - 07:00									
07:00 - 08:00	4	2270	0.011	4	2270	0.000	4	2270	0.011
08:00 - 09:00	4	2270	0.011	4	2270	0.000	4	2270	0.011
09:00 - 10:00	4	2270	0.121	4	2270	0.110	4	2270	0.231
10:00 - 11:00	4	2270	0.066	4	2270	0.099	4	2270	0.165
11:00 - 12:00	4	2270	0.055	4	2270	0.044	4	2270	0.099
12:00 - 13:00	4	2270	0.077	4	2270	0.121	4	2270	0.198
13:00 - 14:00	4	2270	0.099	4	2270	0.088	4	2270	0.187
14:00 - 15:00	4	2270	0.044	4	2270	0.044	4	2270	0.088
15:00 - 16:00	4	2270	0.022	4	2270	0.033	4	2270	0.055
16:00 - 17:00	4	2270	0.088	4	2270	0.077	4	2270	0.165
17:00 - 18:00	4	2270	0.099	4	2270	0.121	4	2270	0.220
18:00 - 19:00	4	2270	0.099	4	2270	0.077	4	2270	0.176
19:00 - 20:00	4	2270	0.077	4	2270	0.055	4	2270	0.132
20:00 - 21:00	4	2270	0.000	4	2270	0.000	4	2270	0.000
21:00 - 22:00	4	2270	0.000	4	2270	0.000	4	2270	0.000
22:00 - 23:00	1	2300	0.000	1	2300	0.000	1	2300	0.000
23:00 - 24:00									
Total Rates:			0.869			0.869			1.738

This section displays the trip rate results based on the selected set of surveys and the selected count type (shown just above the table). It is split by three main columns, representing arrivals trips, departures trips, and total trips (arrivals plus departures). Within each of these main columns are three sub-columns. These display the number of survey days where count data is included (per time period), the average value of the selected trip rate calculation parameter (per time period), and the trip rate result (per time period). Total trip rates (the sum of the column) are also displayed at the foot of the table.

To obtain a trip rate, the average (mean) trip rate parameter value (TRP) is first calculated for all selected survey days that have count data available for the stated time period. The average (mean) number of arrivals, departures or totals (whichever applies) is also calculated (COUNT) for all selected survey days that have count data available for the stated time period. Then, the average count is divided by the average trip rate parameter value, and multiplied by the stated calculation factor (shown just above the table and abbreviated here as FACT). So, the method is: $COUNT/TRP*FACT$. Trip rates are then rounded to 3 decimal places.

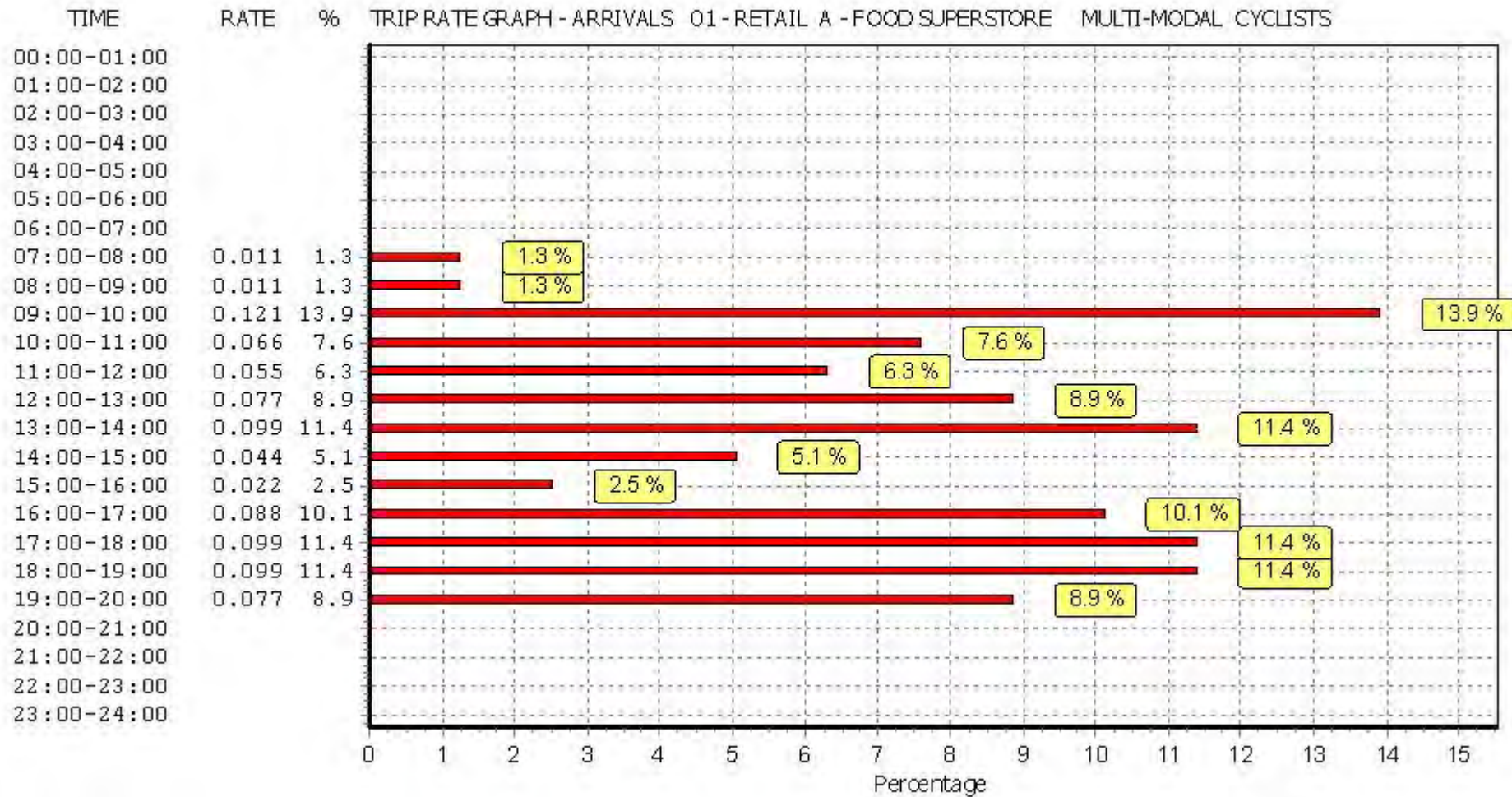

This graph is a visual representation of the trip rate calculation results screen. The same time periods and trip rates are displayed, but in addition there is an additional column showing the percentage of the total trip rate by individual time period, allowing peak periods to be easily identified through observation. Note that the type of count and the selected direction is shown at the top of the graph.

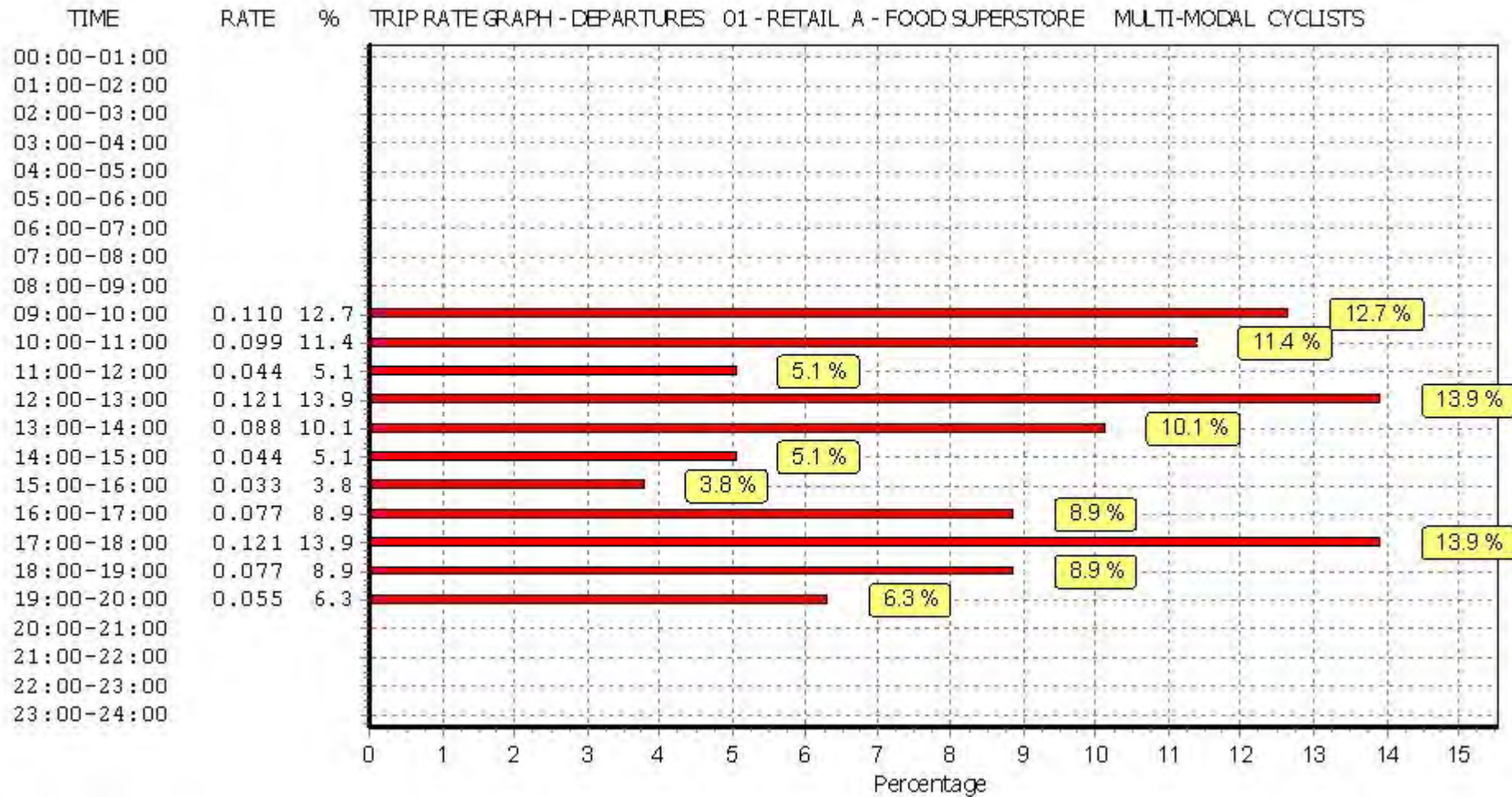

This graph is a visual representation of the trip rate calculation results screen. The same time periods and trip rates are displayed, but in addition there is an additional column showing the percentage of the total trip rate by individual time period, allowing peak periods to be easily identified through observation. Note that the type of count and the selected direction is shown at the top of the graph.

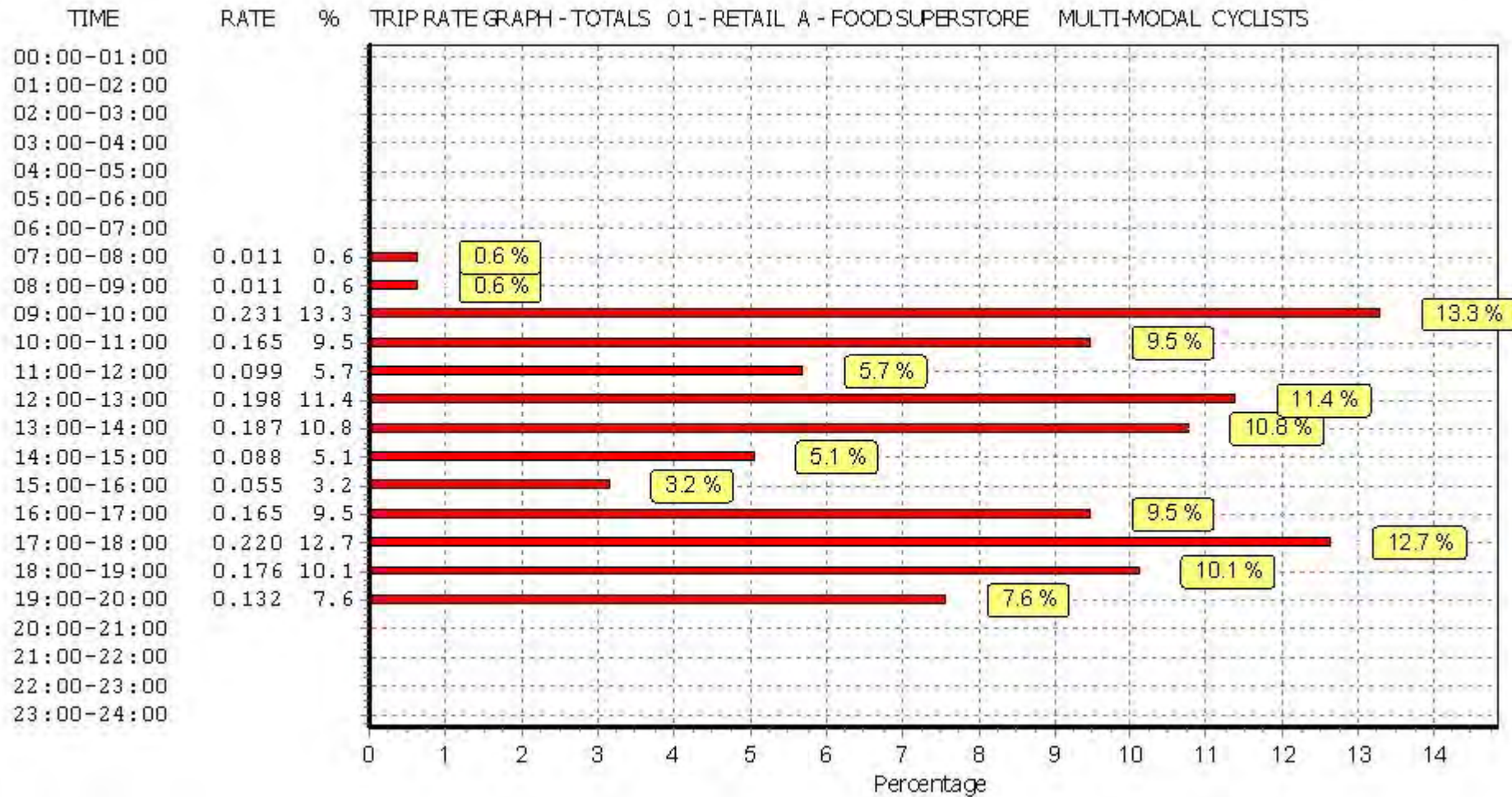

This graph is a visual representation of the trip rate calculation results screen. The same time periods and trip rates are displayed, but in addition there is an additional column showing the percentage of the total trip rate by individual time period, allowing peak periods to be easily identified through observation. Note that the type of count and the selected direction is shown at the top of the graph.

TRIP RATE for Land Use 01 - RETAIL/A - FOOD SUPERSTORE

MULTI-MODAL VEHICLE OCCUPANTS

Calculation factor: 100 sqm

BOLD print indicates peak (busiest) period

Time Range	ARRIVALS			DEPARTURES			TOTALS		
	No. Days	Ave. GFA	Trip Rate	No. Days	Ave. GFA	Trip Rate	No. Days	Ave. GFA	Trip Rate
00:00 - 01:00									
01:00 - 02:00									
02:00 - 03:00									
03:00 - 04:00									
04:00 - 05:00									
05:00 - 06:00									
06:00 - 07:00									
07:00 - 08:00	4	2270	0.936	4	2270	0.628	4	2270	1.564
08:00 - 09:00	4	2270	3.293	4	2270	2.368	4	2270	5.661
09:00 - 10:00	4	2270	5.540	4	2270	4.526	4	2270	10.066
10:00 - 11:00	4	2270	6.630	4	2270	6.861	4	2270	13.491
11:00 - 12:00	4	2270	7.941	4	2270	7.258	4	2270	15.199
12:00 - 13:00	4	2270	7.874	4	2270	7.830	4	2270	15.704
13:00 - 14:00	4	2270	8.370	4	2270	7.863	4	2270	16.233
14:00 - 15:00	4	2270	7.896	4	2270	7.511	4	2270	15.407
15:00 - 16:00	4	2270	8.315	4	2270	7.610	4	2270	15.925
16:00 - 17:00	4	2270	8.535	4	2270	7.963	4	2270	16.498
17:00 - 18:00	4	2270	5.914	4	2270	7.720	4	2270	13.634
18:00 - 19:00	4	2270	5.672	4	2270	6.729	4	2270	12.401
19:00 - 20:00	4	2270	3.634	4	2270	5.143	4	2270	8.777
20:00 - 21:00	4	2270	1.454	4	2270	2.137	4	2270	3.591
21:00 - 22:00	4	2270	0.617	4	2270	0.892	4	2270	1.509
22:00 - 23:00	1	2300	0.043	1	2300	0.130	1	2300	0.173
23:00 - 24:00									
Total Rates:			82.664			83.169			165.833

This section displays the trip rate results based on the selected set of surveys and the selected count type (shown just above the table). It is split by three main columns, representing arrivals trips, departures trips, and total trips (arrivals plus departures). Within each of these main columns are three sub-columns. These display the number of survey days where count data is included (per time period), the average value of the selected trip rate calculation parameter (per time period), and the trip rate result (per time period). Total trip rates (the sum of the column) are also displayed at the foot of the table.

To obtain a trip rate, the average (mean) trip rate parameter value (TRP) is first calculated for all selected survey days that have count data available for the stated time period. The average (mean) number of arrivals, departures or totals (whichever applies) is also calculated (COUNT) for all selected survey days that have count data available for the stated time period. Then, the average count is divided by the average trip rate parameter value, and multiplied by the stated calculation factor (shown just above the table and abbreviated here as FACT). So, the method is: $COUNT/TRP*FACT$. Trip rates are then rounded to 3 decimal places.

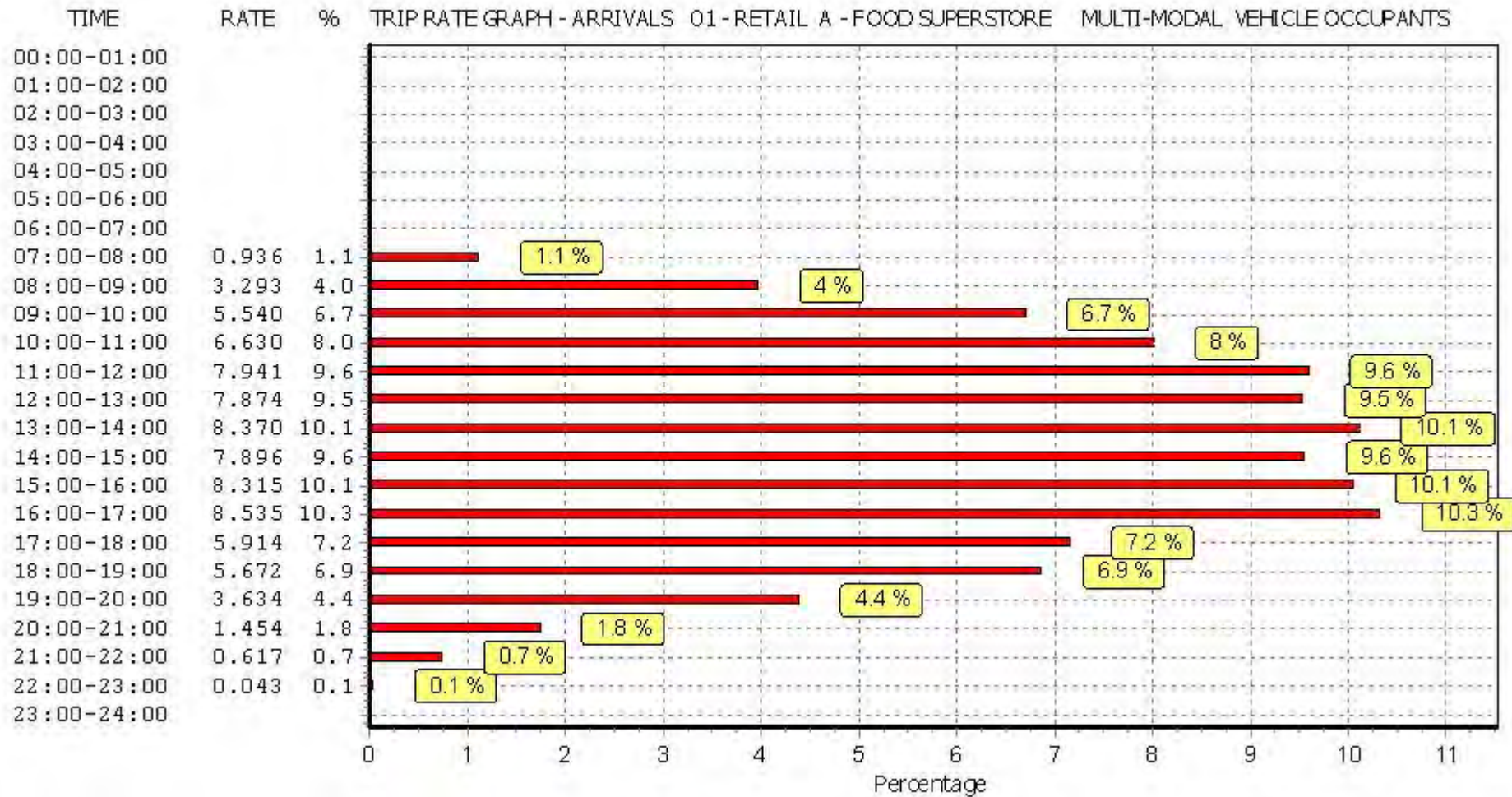

This graph is a visual representation of the trip rate calculation results screen. The same time periods and trip rates are displayed, but in addition there is an additional column showing the percentage of the total trip rate by individual time period, allowing peak periods to be easily identified through observation. Note that the type of count and the selected direction is shown at the top of the graph.

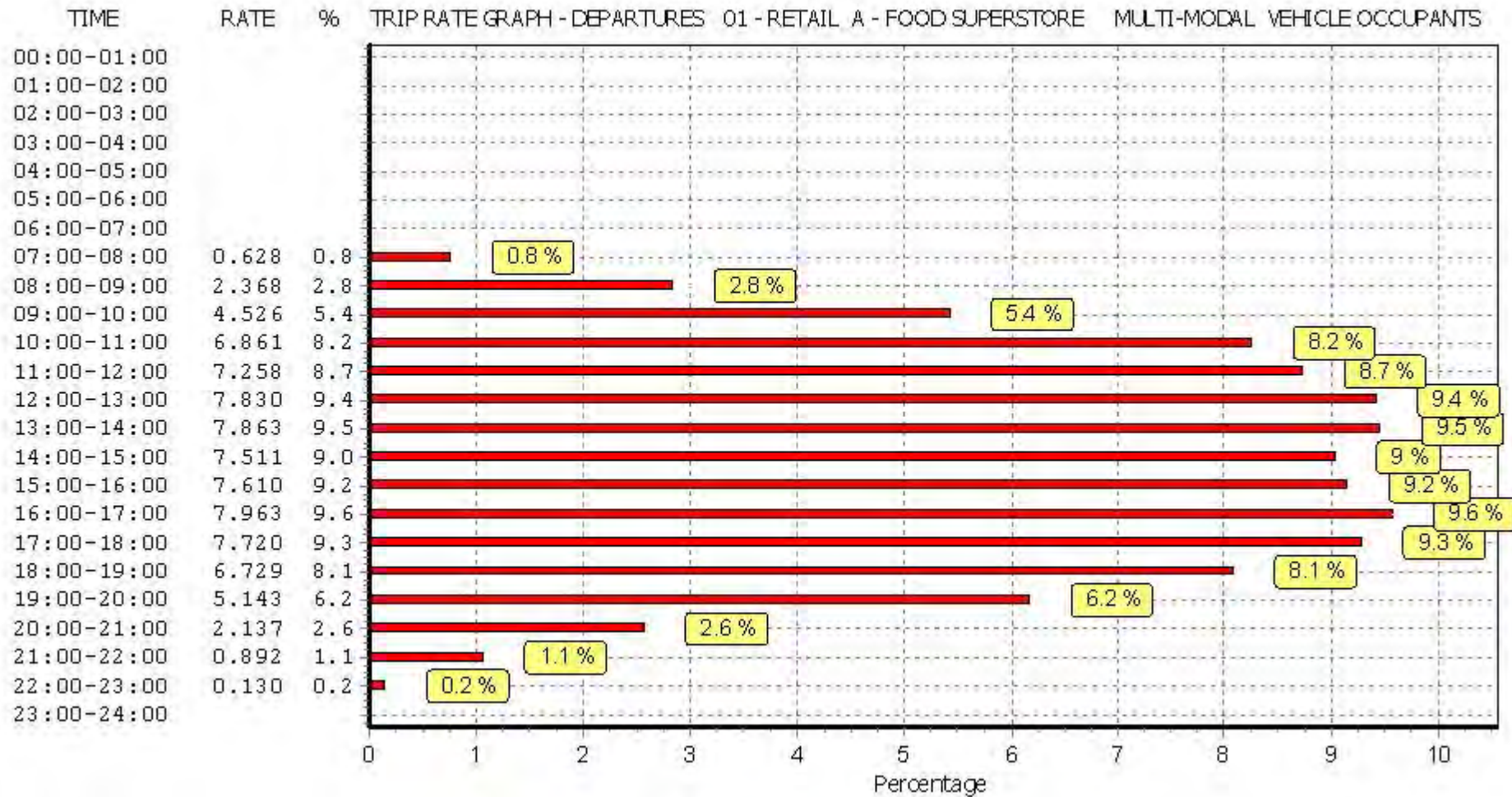

This graph is a visual representation of the trip rate calculation results screen. The same time periods and trip rates are displayed, but in addition there is an additional column showing the percentage of the total trip rate by individual time period, allowing peak periods to be easily identified through observation. Note that the type of count and the selected direction is shown at the top of the graph.

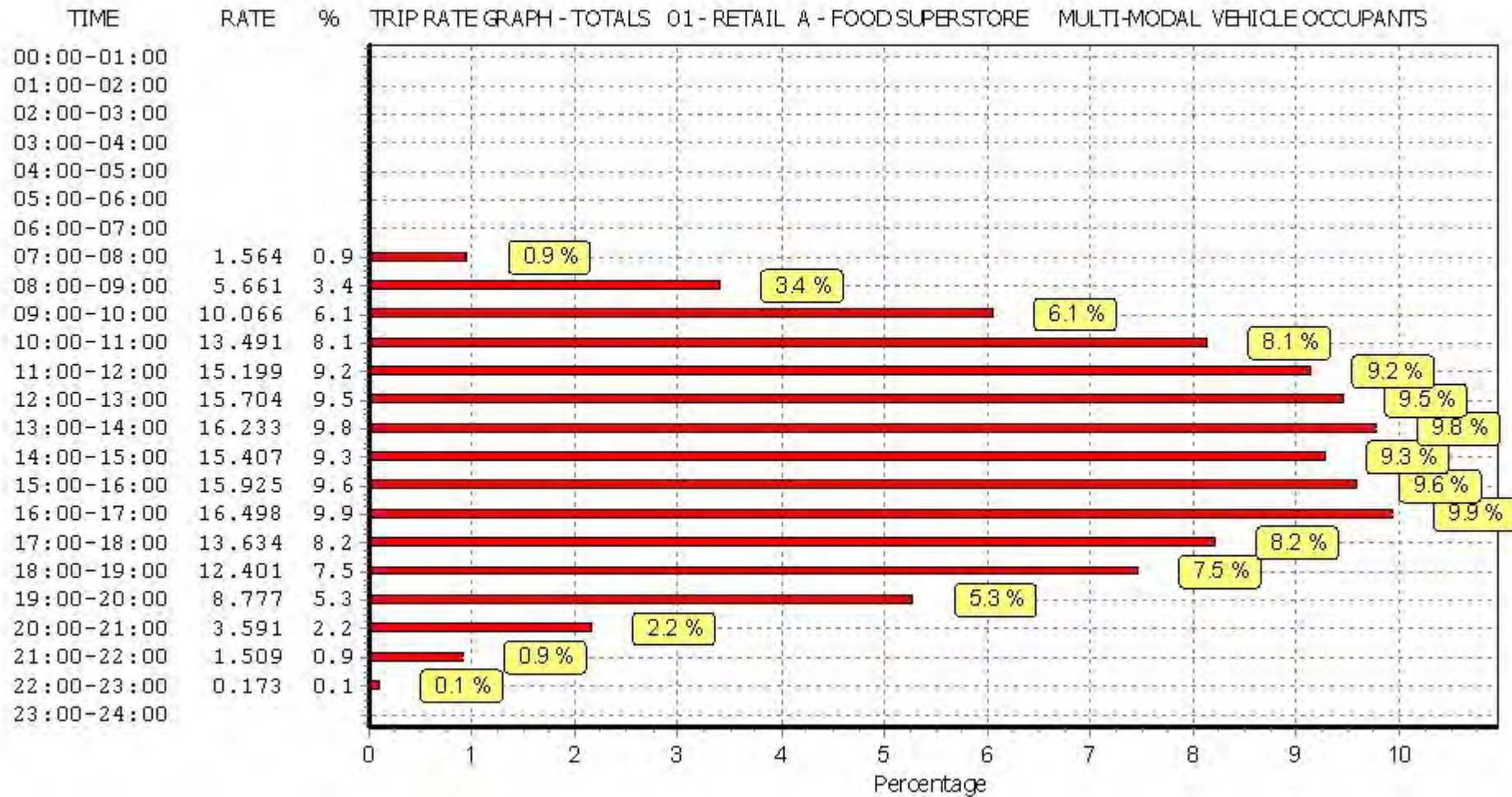

This graph is a visual representation of the trip rate calculation results screen. The same time periods and trip rates are displayed, but in addition there is an additional column showing the percentage of the total trip rate by individual time period, allowing peak periods to be easily identified through observation. Note that the type of count and the selected direction is shown at the top of the graph.

TRIP RATE for Land Use 01 - RETAIL/A - FOOD SUPERSTORE

MULTI-MODAL PEDESTRIANS

Calculation factor: 100 sqm

BOLD print indicates peak (busiest) period

Time Range	ARRIVALS			DEPARTURES			TOTALS		
	No. Days	Ave. GFA	Trip Rate	No. Days	Ave. GFA	Trip Rate	No. Days	Ave. GFA	Trip Rate
00:00 - 01:00									
01:00 - 02:00									
02:00 - 03:00									
03:00 - 04:00									
04:00 - 05:00									
05:00 - 06:00									
06:00 - 07:00									
07:00 - 08:00	4	2270	0.187	4	2270	0.077	4	2270	0.264
08:00 - 09:00	4	2270	0.837	4	2270	0.683	4	2270	1.520
09:00 - 10:00	4	2270	1.233	4	2270	1.244	4	2270	2.477
10:00 - 11:00	4	2270	1.839	4	2270	1.652	4	2270	3.491
11:00 - 12:00	4	2270	1.597	4	2270	1.498	4	2270	3.095
12:00 - 13:00	4	2270	1.883	4	2270	2.291	4	2270	4.174
13:00 - 14:00	4	2270	1.960	4	2270	1.652	4	2270	3.612
14:00 - 15:00	4	2270	1.916	4	2270	1.553	4	2270	3.469
15:00 - 16:00	4	2270	1.410	4	2270	1.300	4	2270	2.710
16:00 - 17:00	4	2270	1.696	4	2270	1.465	4	2270	3.161
17:00 - 18:00	4	2270	1.465	4	2270	1.531	4	2270	2.996
18:00 - 19:00	4	2270	0.969	4	2270	1.134	4	2270	2.103
19:00 - 20:00	4	2270	1.013	4	2270	1.145	4	2270	2.158
20:00 - 21:00	4	2270	0.374	4	2270	0.683	4	2270	1.057
21:00 - 22:00	4	2270	0.275	4	2270	0.275	4	2270	0.550
22:00 - 23:00	1	2300	0.000	1	2300	0.130	1	2300	0.130
23:00 - 24:00									
Total Rates:			18.654			18.313			36.967

This section displays the trip rate results based on the selected set of surveys and the selected count type (shown just above the table). It is split by three main columns, representing arrivals trips, departures trips, and total trips (arrivals plus departures). Within each of these main columns are three sub-columns. These display the number of survey days where count data is included (per time period), the average value of the selected trip rate calculation parameter (per time period), and the trip rate result (per time period). Total trip rates (the sum of the column) are also displayed at the foot of the table.

To obtain a trip rate, the average (mean) trip rate parameter value (TRP) is first calculated for all selected survey days that have count data available for the stated time period. The average (mean) number of arrivals, departures or totals (whichever applies) is also calculated (COUNT) for all selected survey days that have count data available for the stated time period. Then, the average count is divided by the average trip rate parameter value, and multiplied by the stated calculation factor (shown just above the table and abbreviated here as FACT). So, the method is: $COUNT/TRP*FACT$. Trip rates are then rounded to 3 decimal places.

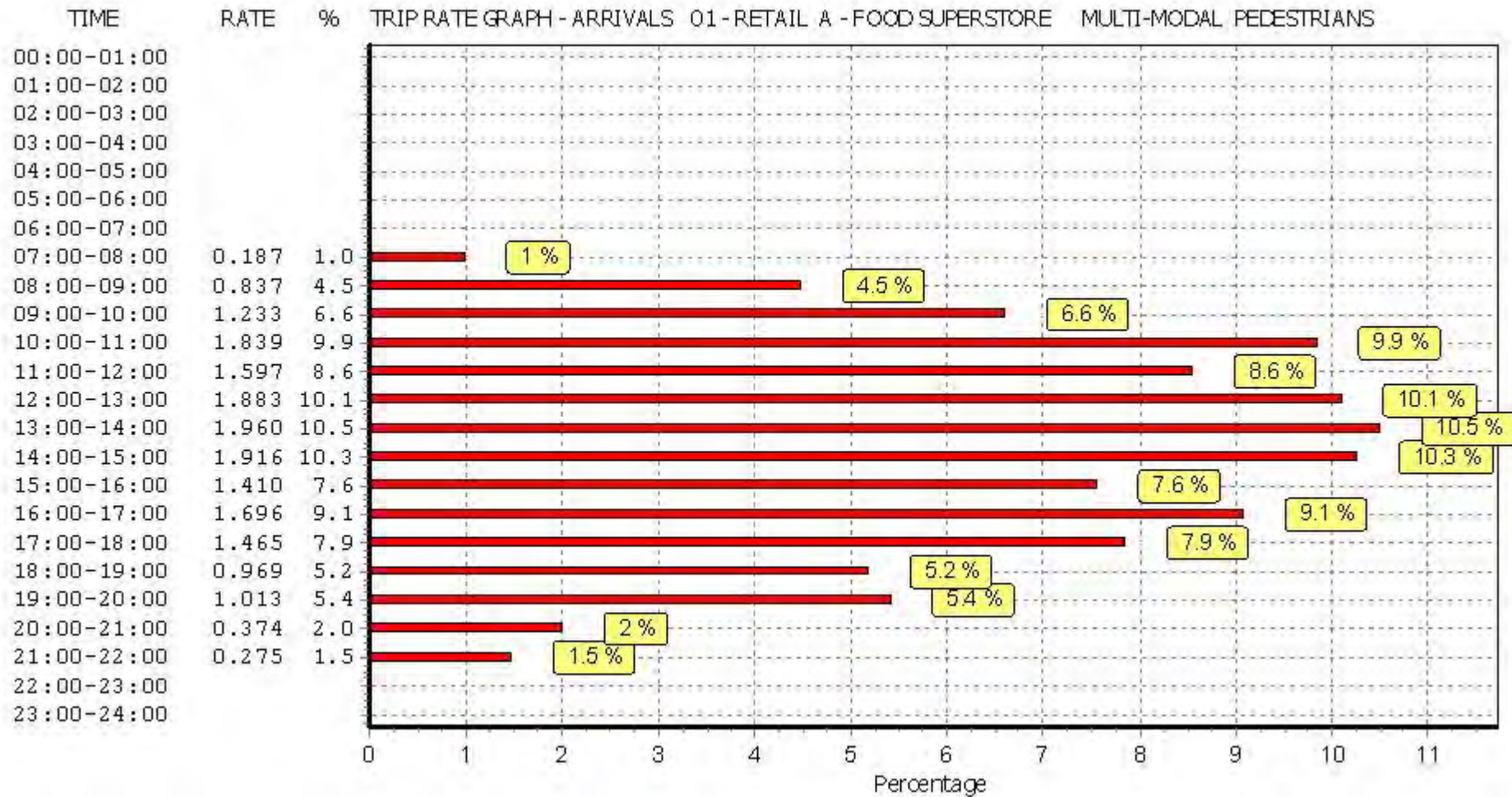

This graph is a visual representation of the trip rate calculation results screen. The same time periods and trip rates are displayed, but in addition there is an additional column showing the percentage of the total trip rate by individual time period, allowing peak periods to be easily identified through observation. Note that the type of count and the selected direction is shown at the top of the graph.

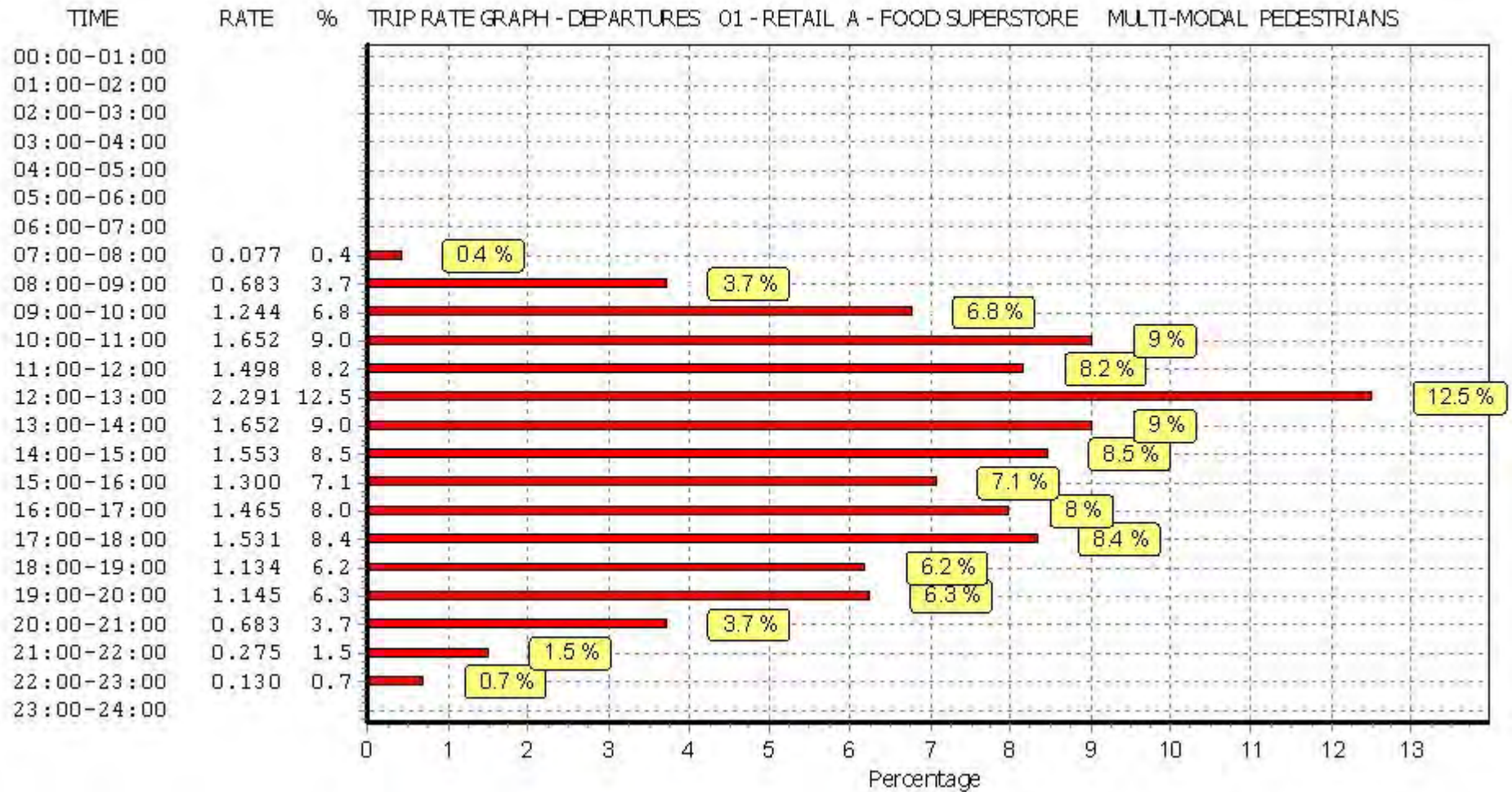

This graph is a visual representation of the trip rate calculation results screen. The same time periods and trip rates are displayed, but in addition there is an additional column showing the percentage of the total trip rate by individual time period, allowing peak periods to be easily identified through observation. Note that the type of count and the selected direction is shown at the top of the graph.

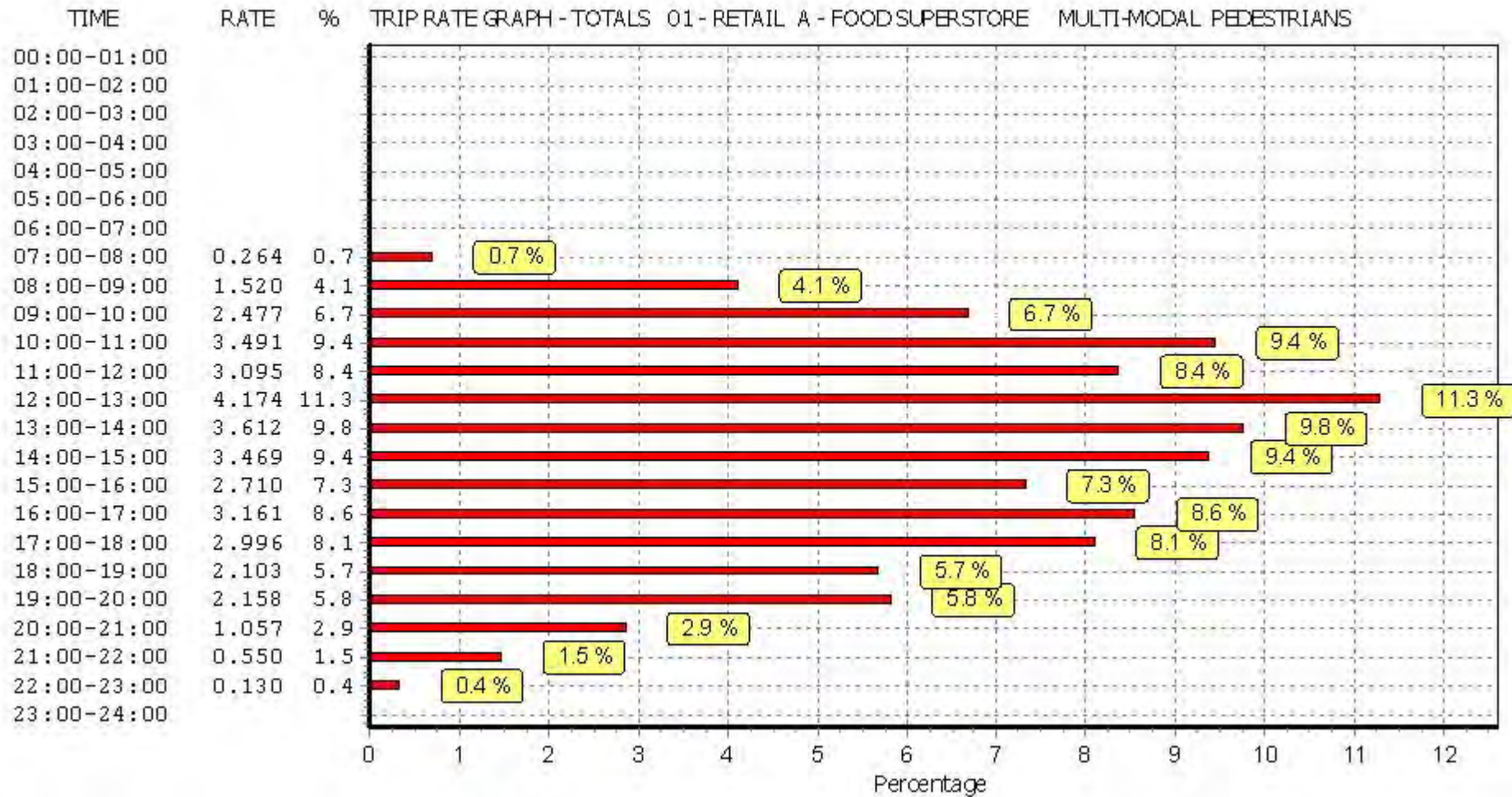

This graph is a visual representation of the trip rate calculation results screen. The same time periods and trip rates are displayed, but in addition there is an additional column showing the percentage of the total trip rate by individual time period, allowing peak periods to be easily identified through observation. Note that the type of count and the selected direction is shown at the top of the graph.

TRIP RATE for Land Use 01 - RETAIL/A - FOOD SUPERSTORE

MULTI-MODAL BUS/TRAM PASSENGERS

Calculation factor: 100 sqm

BOLD print indicates peak (busiest) period

Time Range	ARRIVALS			DEPARTURES			TOTALS		
	No. Days	Ave. GFA	Trip Rate	No. Days	Ave. GFA	Trip Rate	No. Days	Ave. GFA	Trip Rate
00:00 - 01:00									
01:00 - 02:00									
02:00 - 03:00									
03:00 - 04:00									
04:00 - 05:00									
05:00 - 06:00									
06:00 - 07:00									
07:00 - 08:00	4	2270	0.000	4	2270	0.000	4	2270	0.000
08:00 - 09:00	4	2270	0.132	4	2270	0.077	4	2270	0.209
09:00 - 10:00	4	2270	0.286	4	2270	0.110	4	2270	0.396
10:00 - 11:00	4	2270	0.242	4	2270	0.275	4	2270	0.517
11:00 - 12:00	4	2270	0.154	4	2270	0.220	4	2270	0.374
12:00 - 13:00	4	2270	0.374	4	2270	0.242	4	2270	0.616
13:00 - 14:00	4	2270	0.352	4	2270	0.396	4	2270	0.748
14:00 - 15:00	4	2270	0.264	4	2270	0.264	4	2270	0.528
15:00 - 16:00	4	2270	0.385	4	2270	0.264	4	2270	0.649
16:00 - 17:00	4	2270	0.330	4	2270	0.341	4	2270	0.671
17:00 - 18:00	4	2270	0.319	4	2270	0.374	4	2270	0.693
18:00 - 19:00	4	2270	0.198	4	2270	0.430	4	2270	0.628
19:00 - 20:00	4	2270	0.121	4	2270	0.110	4	2270	0.231
20:00 - 21:00	4	2270	0.033	4	2270	0.066	4	2270	0.099
21:00 - 22:00	4	2270	0.033	4	2270	0.033	4	2270	0.066
22:00 - 23:00	1	2300	0.000	1	2300	0.000	1	2300	0.000
23:00 - 24:00									
Total Rates:			3.223			3.202			6.425

This section displays the trip rate results based on the selected set of surveys and the selected count type (shown just above the table). It is split by three main columns, representing arrivals trips, departures trips, and total trips (arrivals plus departures). Within each of these main columns are three sub-columns. These display the number of survey days where count data is included (per time period), the average value of the selected trip rate calculation parameter (per time period), and the trip rate result (per time period). Total trip rates (the sum of the column) are also displayed at the foot of the table.

To obtain a trip rate, the average (mean) trip rate parameter value (TRP) is first calculated for all selected survey days that have count data available for the stated time period. The average (mean) number of arrivals, departures or totals (whichever applies) is also calculated (COUNT) for all selected survey days that have count data available for the stated time period. Then, the average count is divided by the average trip rate parameter value, and multiplied by the stated calculation factor (shown just above the table and abbreviated here as FACT). So, the method is: $COUNT/TRP*FACT$. Trip rates are then rounded to 3 decimal places.

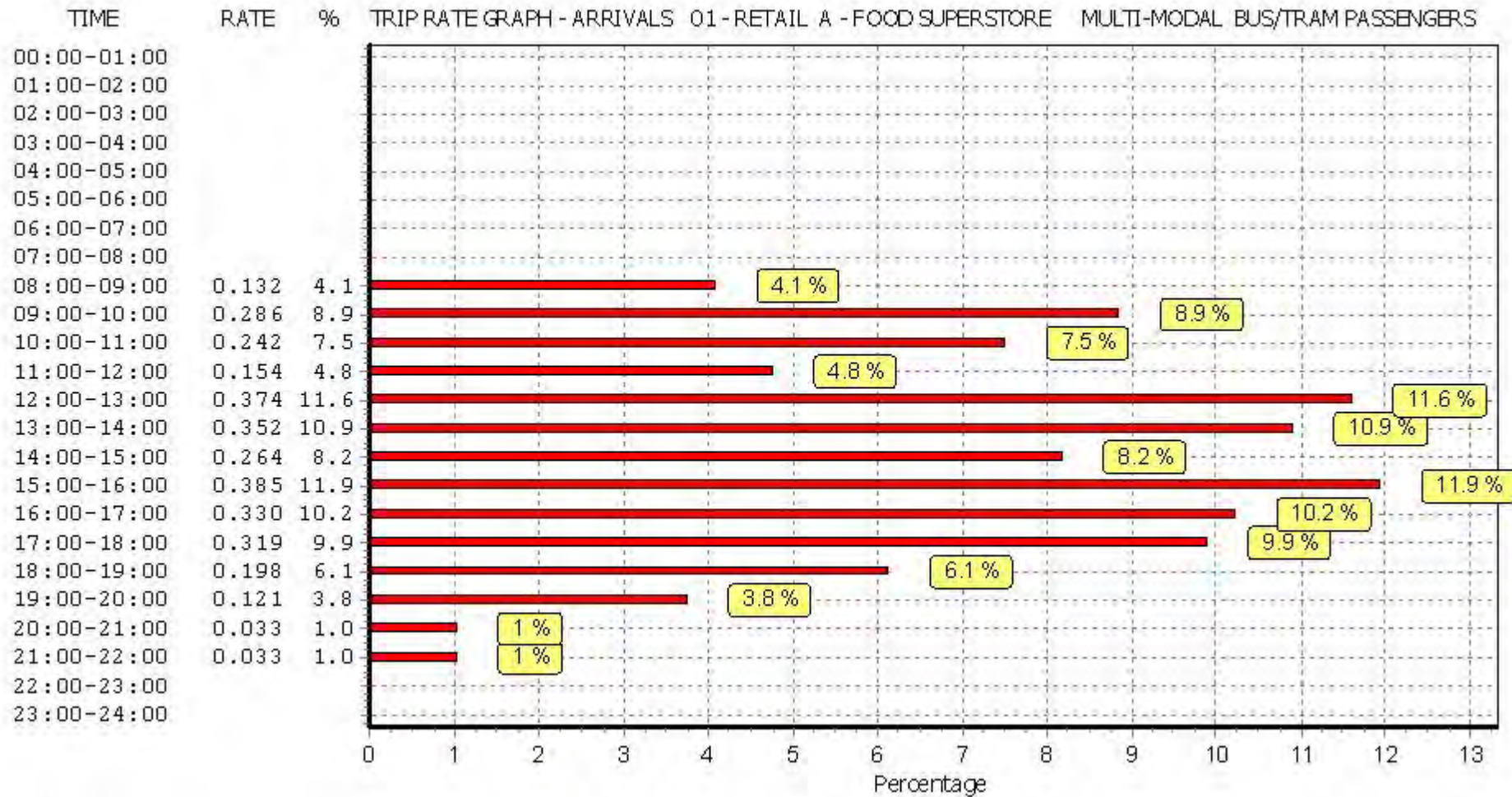

This graph is a visual representation of the trip rate calculation results screen. The same time periods and trip rates are displayed, but in addition there is an additional column showing the percentage of the total trip rate by individual time period, allowing peak periods to be easily identified through observation. Note that the type of count and the selected direction is shown at the top of the graph.

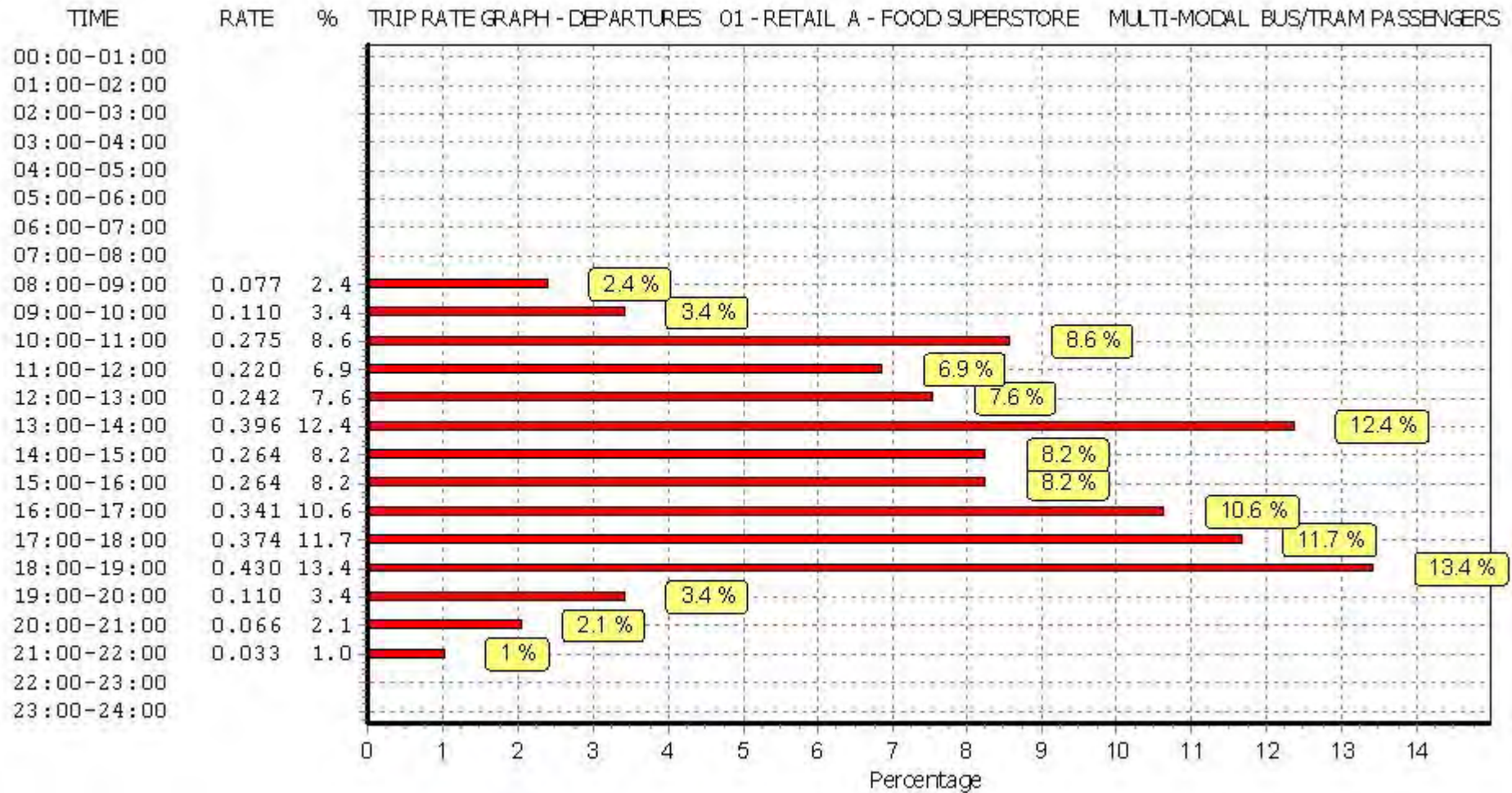

This graph is a visual representation of the trip rate calculation results screen. The same time periods and trip rates are displayed, but in addition there is an additional column showing the percentage of the total trip rate by individual time period, allowing peak periods to be easily identified through observation. Note that the type of count and the selected direction is shown at the top of the graph.

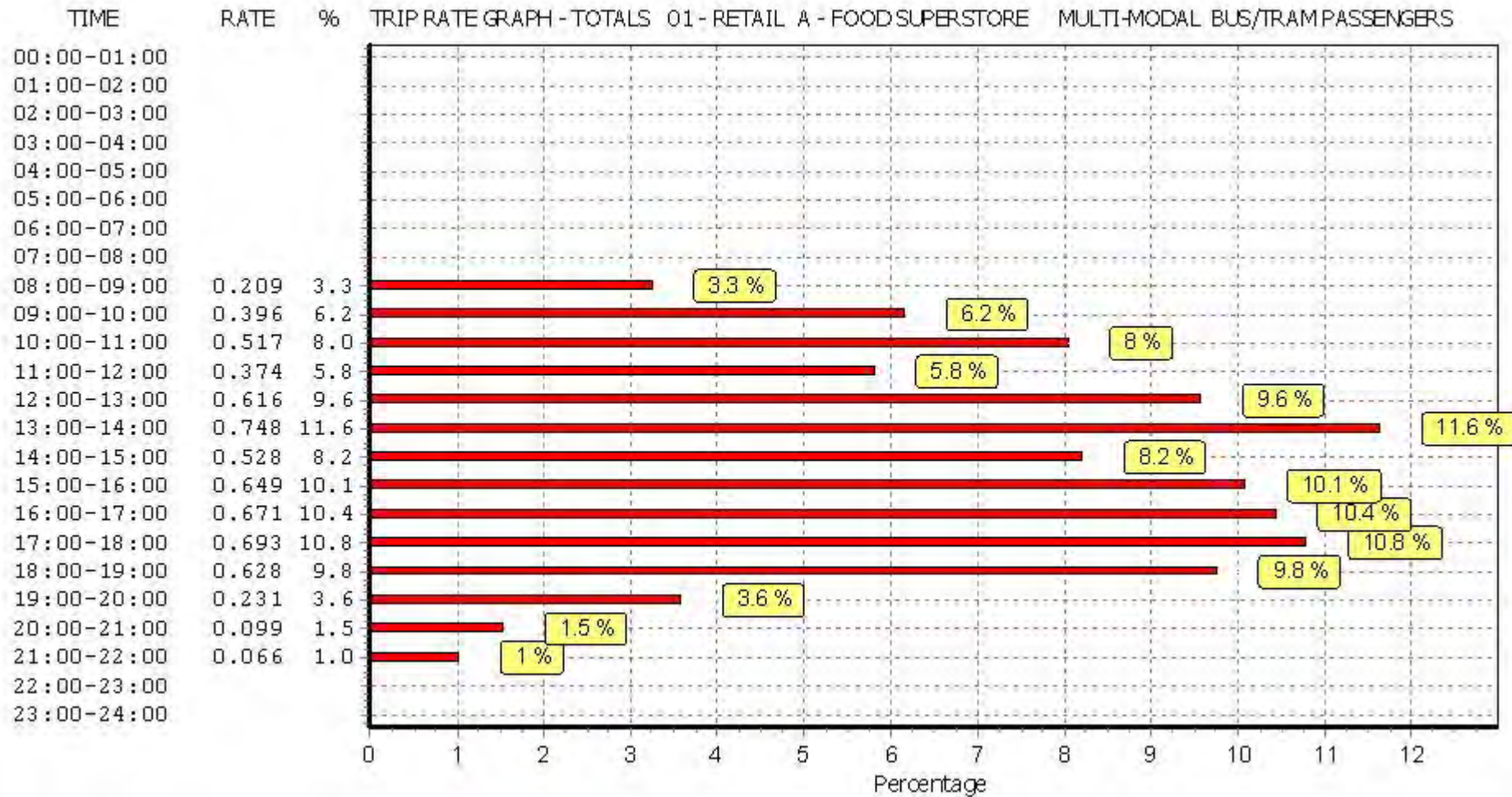

This graph is a visual representation of the trip rate calculation results screen. The same time periods and trip rates are displayed, but in addition there is an additional column showing the percentage of the total trip rate by individual time period, allowing peak periods to be easily identified through observation. Note that the type of count and the selected direction is shown at the top of the graph.

TRIP RATE for Land Use 01 - RETAIL/A - FOOD SUPERSTORE

MULTI-MODAL TOTAL RAIL PASSENGERS

Calculation factor: 100 sqm

BOLD print indicates peak (busiest) period

Time Range	ARRIVALS			DEPARTURES			TOTALS		
	No. Days	Ave. GFA	Trip Rate	No. Days	Ave. GFA	Trip Rate	No. Days	Ave. GFA	Trip Rate
00:00 - 01:00									
01:00 - 02:00									
02:00 - 03:00									
03:00 - 04:00									
04:00 - 05:00									
05:00 - 06:00									
06:00 - 07:00									
07:00 - 08:00	4	2270	0.000	4	2270	0.000	4	2270	0.000
08:00 - 09:00	4	2270	0.011	4	2270	0.011	4	2270	0.022
09:00 - 10:00	4	2270	0.000	4	2270	0.000	4	2270	0.000
10:00 - 11:00	4	2270	0.000	4	2270	0.000	4	2270	0.000
11:00 - 12:00	4	2270	0.000	4	2270	0.000	4	2270	0.000
12:00 - 13:00	4	2270	0.000	4	2270	0.000	4	2270	0.000
13:00 - 14:00	4	2270	0.011	4	2270	0.000	4	2270	0.011
14:00 - 15:00	4	2270	0.000	4	2270	0.022	4	2270	0.022
15:00 - 16:00	4	2270	0.000	4	2270	0.066	4	2270	0.066
16:00 - 17:00	4	2270	0.022	4	2270	0.022	4	2270	0.044
17:00 - 18:00	4	2270	0.033	4	2270	0.044	4	2270	0.077
18:00 - 19:00	4	2270	0.011	4	2270	0.011	4	2270	0.022
19:00 - 20:00	4	2270	0.000	4	2270	0.011	4	2270	0.011
20:00 - 21:00	4	2270	0.000	4	2270	0.000	4	2270	0.000
21:00 - 22:00	4	2270	0.000	4	2270	0.000	4	2270	0.000
22:00 - 23:00	1	2300	0.000	1	2300	0.000	1	2300	0.000
23:00 - 24:00									
Total Rates:			0.088			0.187			0.275

This section displays the trip rate results based on the selected set of surveys and the selected count type (shown just above the table). It is split by three main columns, representing arrivals trips, departures trips, and total trips (arrivals plus departures). Within each of these main columns are three sub-columns. These display the number of survey days where count data is included (per time period), the average value of the selected trip rate calculation parameter (per time period), and the trip rate result (per time period). Total trip rates (the sum of the column) are also displayed at the foot of the table.

To obtain a trip rate, the average (mean) trip rate parameter value (TRP) is first calculated for all selected survey days that have count data available for the stated time period. The average (mean) number of arrivals, departures or totals (whichever applies) is also calculated (COUNT) for all selected survey days that have count data available for the stated time period. Then, the average count is divided by the average trip rate parameter value, and multiplied by the stated calculation factor (shown just above the table and abbreviated here as FACT). So, the method is: $COUNT/TRP*FACT$. Trip rates are then rounded to 3 decimal places.

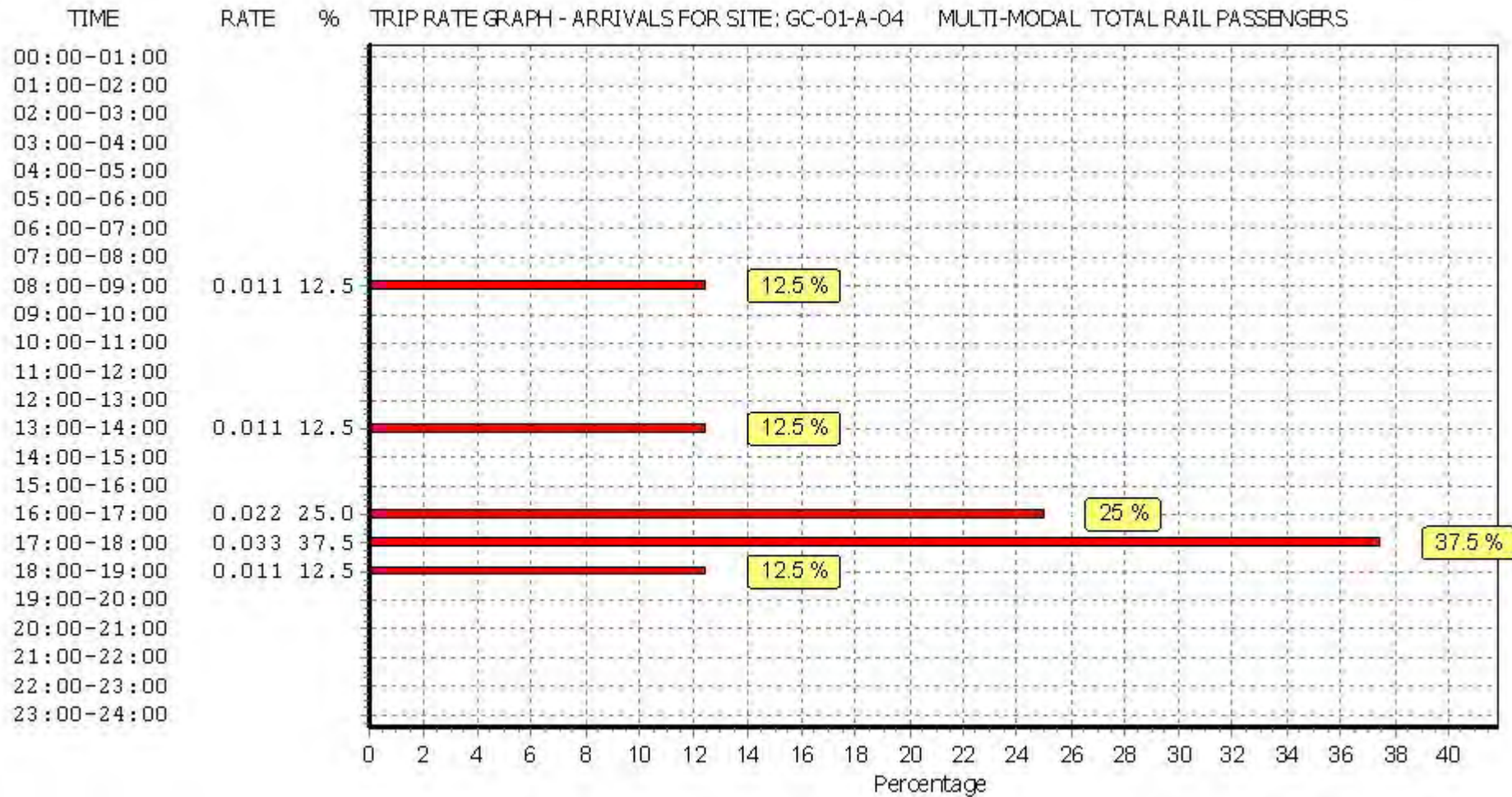

This graph is a visual representation of the trip rate calculation results screen. The same time periods and trip rates are displayed, but in addition there is an additional column showing the percentage of the total trip rate by individual time period, allowing peak periods to be easily identified through observation. Note that the type of count and the selected direction is shown at the top of the graph.

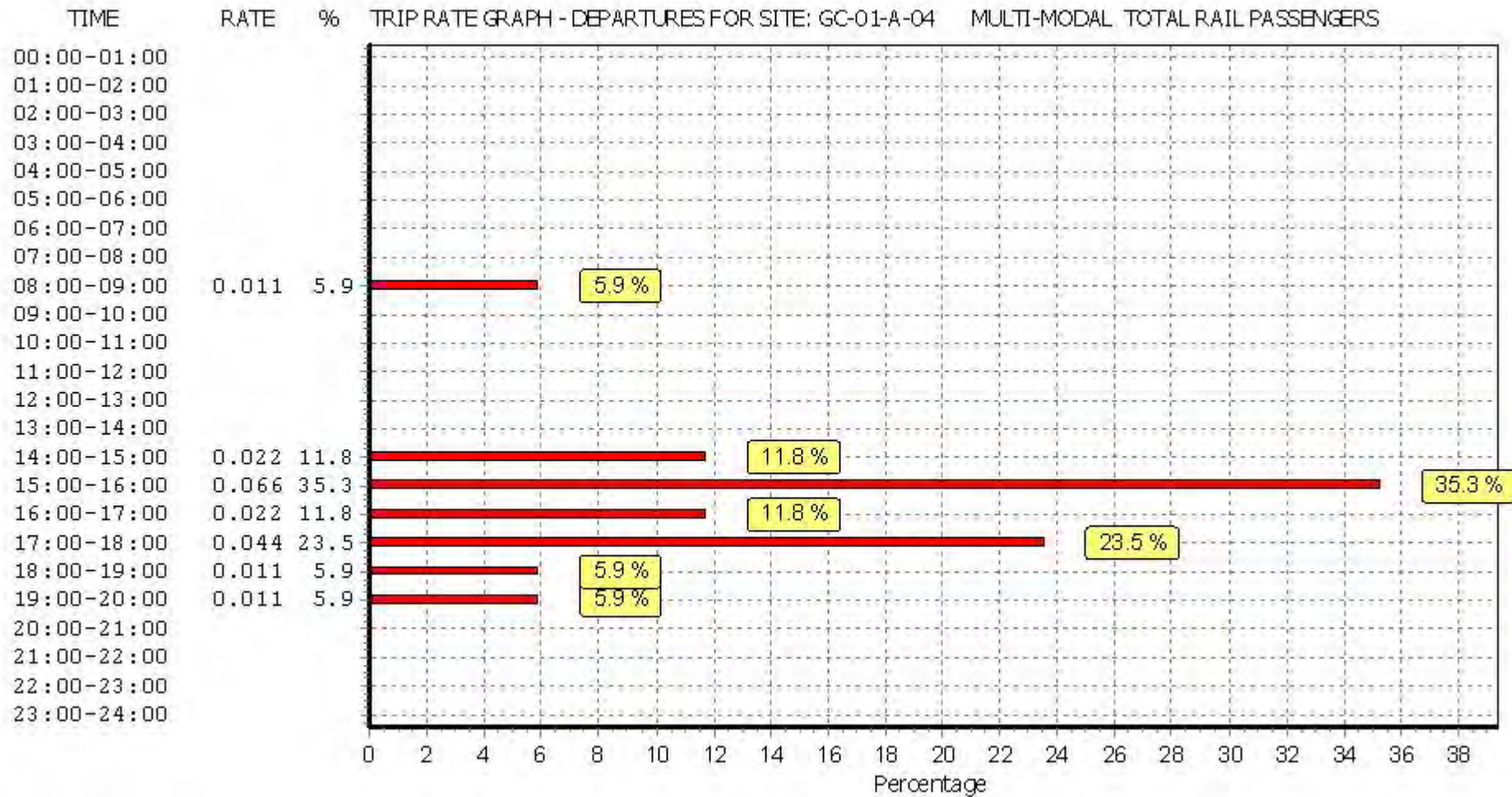

This graph is a visual representation of the trip rate calculation results screen. The same time periods and trip rates are displayed, but in addition there is an additional column showing the percentage of the total trip rate by individual time period, allowing peak periods to be easily identified through observation. Note that the type of count and the selected direction is shown at the top of the graph.

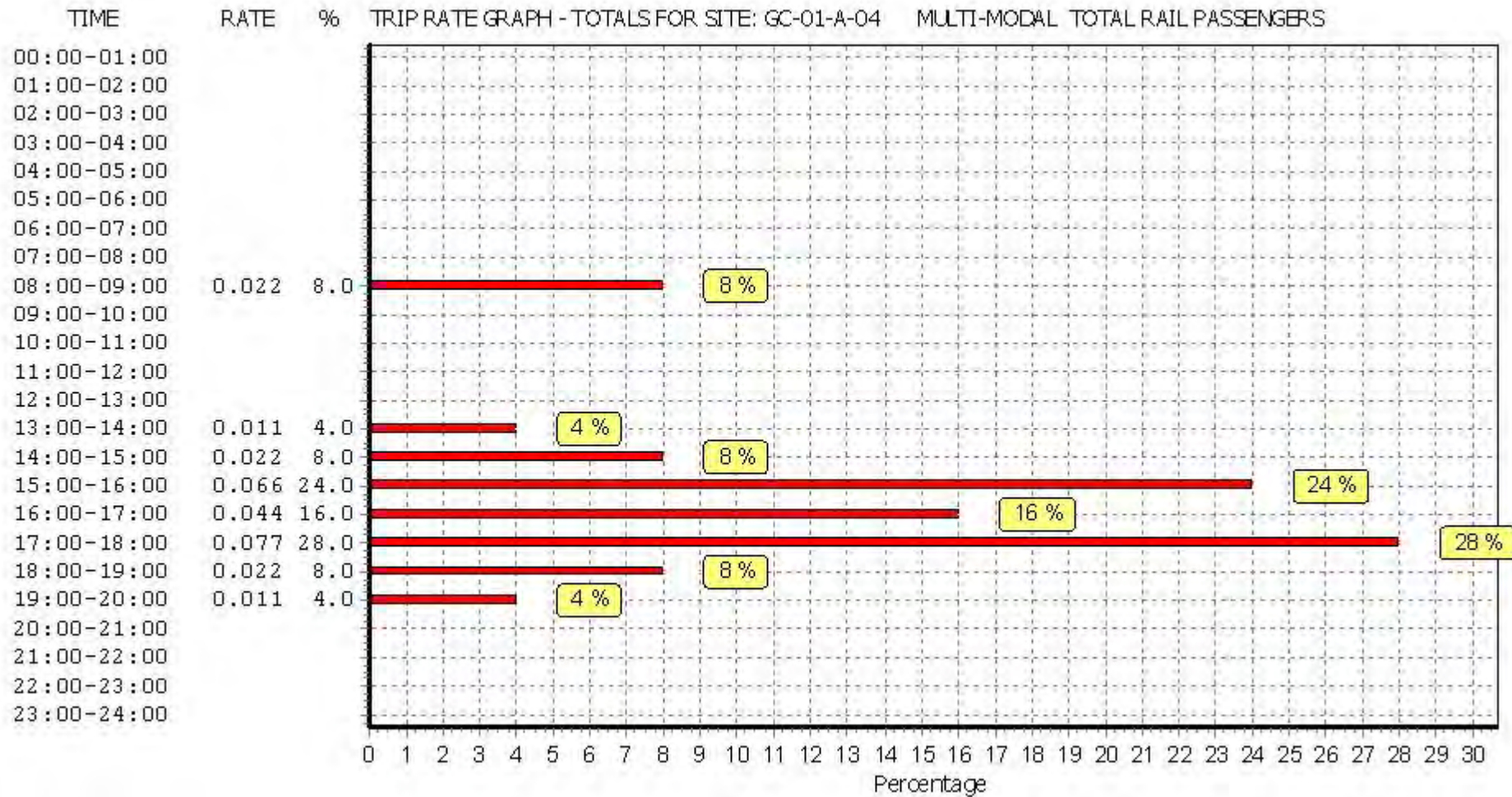

This graph is a visual representation of the trip rate calculation results screen. The same time periods and trip rates are displayed, but in addition there is an additional column showing the percentage of the total trip rate by individual time period, allowing peak periods to be easily identified through observation. Note that the type of count and the selected direction is shown at the top of the graph.

TRIP RATE for Land Use 01 - RETAIL/A - FOOD SUPERSTORE

MULTI-MODAL PUBLIC TRANSPORT USERS

Calculation factor: 100 sqm

BOLD print indicates peak (busiest) period

Time Range	ARRIVALS			DEPARTURES			TOTALS		
	No. Days	Ave. GFA	Trip Rate	No. Days	Ave. GFA	Trip Rate	No. Days	Ave. GFA	Trip Rate
00:00 - 01:00									
01:00 - 02:00									
02:00 - 03:00									
03:00 - 04:00									
04:00 - 05:00									
05:00 - 06:00									
06:00 - 07:00									
07:00 - 08:00	4	2270	0.000	4	2270	0.000	4	2270	0.000
08:00 - 09:00	4	2270	0.143	4	2270	0.088	4	2270	0.231
09:00 - 10:00	4	2270	0.286	4	2270	0.110	4	2270	0.396
10:00 - 11:00	4	2270	0.242	4	2270	0.275	4	2270	0.517
11:00 - 12:00	4	2270	0.154	4	2270	0.220	4	2270	0.374
12:00 - 13:00	4	2270	0.374	4	2270	0.242	4	2270	0.616
13:00 - 14:00	4	2270	0.363	4	2270	0.396	4	2270	0.759
14:00 - 15:00	4	2270	0.264	4	2270	0.286	4	2270	0.550
15:00 - 16:00	4	2270	0.385	4	2270	0.330	4	2270	0.715
16:00 - 17:00	4	2270	0.352	4	2270	0.363	4	2270	0.715
17:00 - 18:00	4	2270	0.352	4	2270	0.419	4	2270	0.771
18:00 - 19:00	4	2270	0.209	4	2270	0.441	4	2270	0.650
19:00 - 20:00	4	2270	0.121	4	2270	0.121	4	2270	0.242
20:00 - 21:00	4	2270	0.033	4	2270	0.066	4	2270	0.099
21:00 - 22:00	4	2270	0.033	4	2270	0.033	4	2270	0.066
22:00 - 23:00	1	2300	0.000	1	2300	0.000	1	2300	0.000
23:00 - 24:00									
Total Rates:			3.311			3.390			6.701

This section displays the trip rate results based on the selected set of surveys and the selected count type (shown just above the table). It is split by three main columns, representing arrivals trips, departures trips, and total trips (arrivals plus departures). Within each of these main columns are three sub-columns. These display the number of survey days where count data is included (per time period), the average value of the selected trip rate calculation parameter (per time period), and the trip rate result (per time period). Total trip rates (the sum of the column) are also displayed at the foot of the table.

To obtain a trip rate, the average (mean) trip rate parameter value (TRP) is first calculated for all selected survey days that have count data available for the stated time period. The average (mean) number of arrivals, departures or totals (whichever applies) is also calculated (COUNT) for all selected survey days that have count data available for the stated time period. Then, the average count is divided by the average trip rate parameter value, and multiplied by the stated calculation factor (shown just above the table and abbreviated here as FACT). So, the method is: $COUNT/TRP*FACT$. Trip rates are then rounded to 3 decimal places.

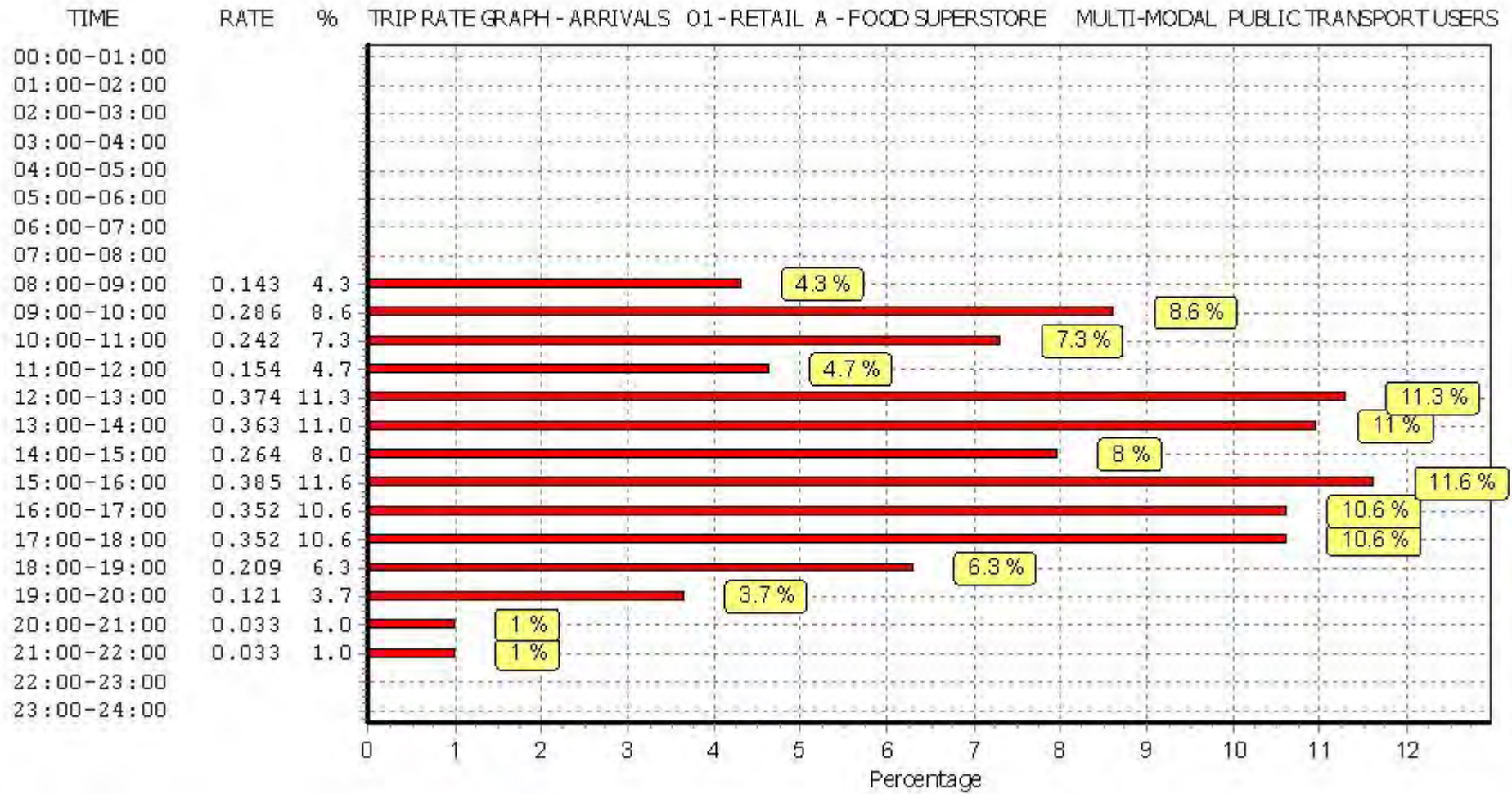

This graph is a visual representation of the trip rate calculation results screen. The same time periods and trip rates are displayed, but in addition there is an additional column showing the percentage of the total trip rate by individual time period, allowing peak periods to be easily identified through observation. Note that the type of count and the selected direction is shown at the top of the graph.

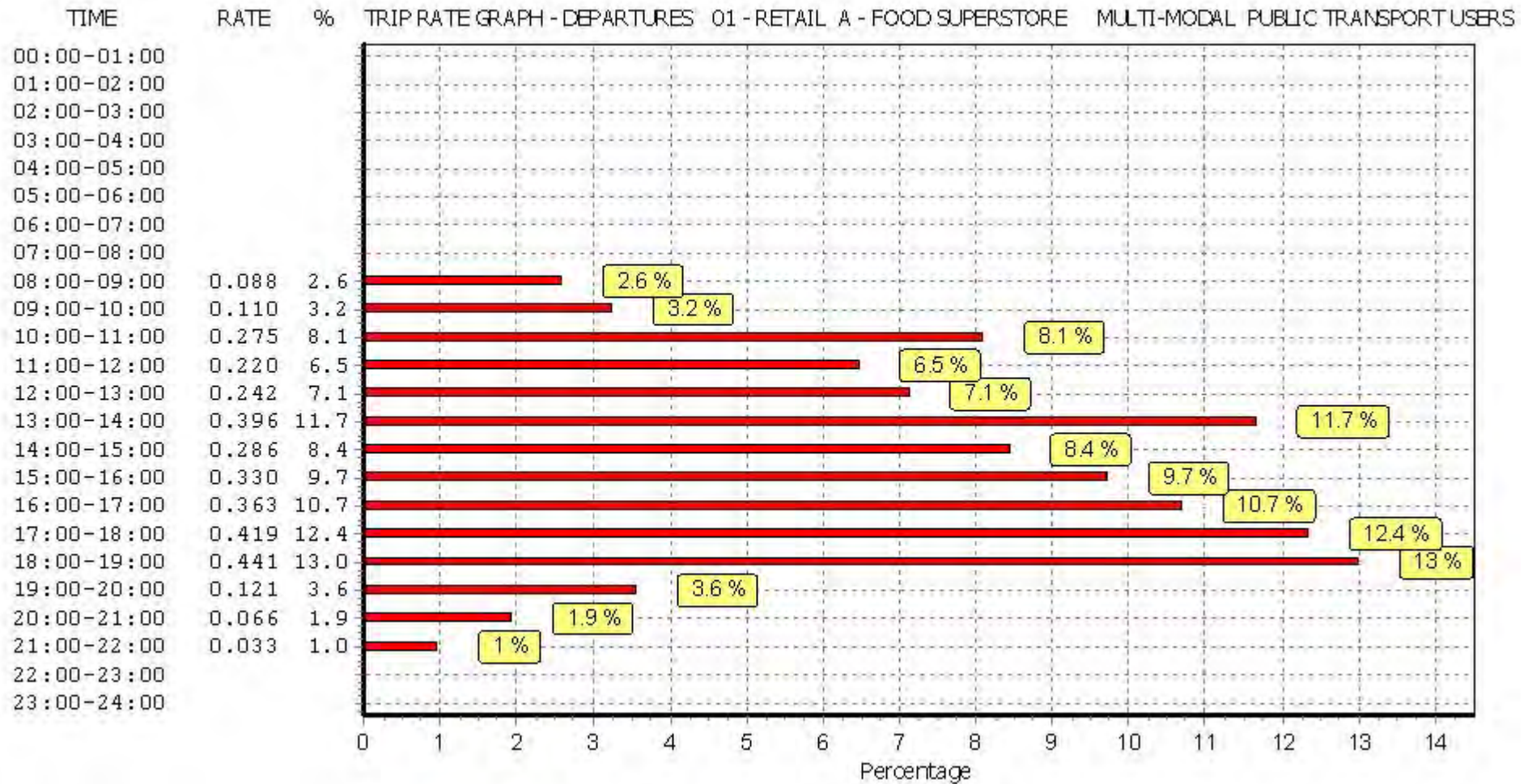

This graph is a visual representation of the trip rate calculation results screen. The same time periods and trip rates are displayed, but in addition there is an additional column showing the percentage of the total trip rate by individual time period, allowing peak periods to be easily identified through observation. Note that the type of count and the selected direction is shown at the top of the graph.

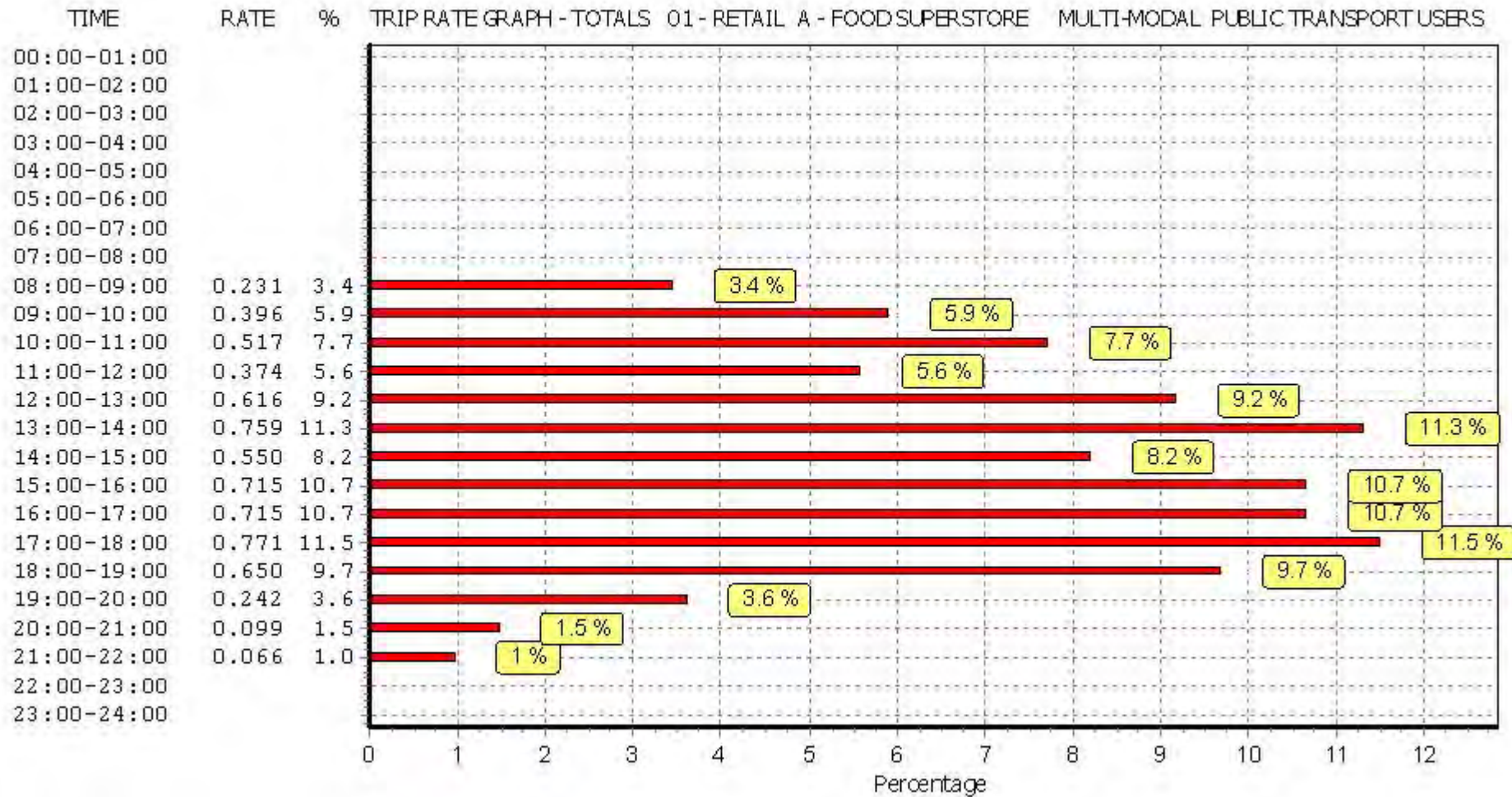

This graph is a visual representation of the trip rate calculation results screen. The same time periods and trip rates are displayed, but in addition there is an additional column showing the percentage of the total trip rate by individual time period, allowing peak periods to be easily identified through observation. Note that the type of count and the selected direction is shown at the top of the graph.

TRIP RATE for Land Use 01 - RETAIL/A - FOOD SUPERSTORE

MULTI-MODAL TOTAL PEOPLE

Calculation factor: 100 sqm

BOLD print indicates peak (busiest) period

Time Range	ARRIVALS			DEPARTURES			TOTALS		
	No. Days	Ave. GFA	Trip Rate	No. Days	Ave. GFA	Trip Rate	No. Days	Ave. GFA	Trip Rate
00:00 - 01:00									
01:00 - 02:00									
02:00 - 03:00									
03:00 - 04:00									
04:00 - 05:00									
05:00 - 06:00									
06:00 - 07:00									
07:00 - 08:00	4	2270	1.134	4	2270	0.705	4	2270	1.839
08:00 - 09:00	4	2270	4.284	4	2270	3.139	4	2270	7.423
09:00 - 10:00	4	2270	7.181	4	2270	5.991	4	2270	13.172
10:00 - 11:00	4	2270	8.778	4	2270	8.888	4	2270	17.666
11:00 - 12:00	4	2270	9.747	4	2270	9.020	4	2270	18.767
12:00 - 13:00	4	2270	10.209	4	2270	10.485	4	2270	20.694
13:00 - 14:00	4	2270	10.793	4	2270	10.000	4	2270	20.793
14:00 - 15:00	4	2270	10.121	4	2270	9.394	4	2270	19.515
15:00 - 16:00	4	2270	10.132	4	2270	9.273	4	2270	19.405
16:00 - 17:00	4	2270	10.672	4	2270	9.868	4	2270	20.540
17:00 - 18:00	4	2270	7.830	4	2270	9.791	4	2270	17.621
18:00 - 19:00	4	2270	6.949	4	2270	8.381	4	2270	15.330
19:00 - 20:00	4	2270	4.846	4	2270	6.465	4	2270	11.311
20:00 - 21:00	4	2270	1.861	4	2270	2.885	4	2270	4.746
21:00 - 22:00	4	2270	0.925	4	2270	1.200	4	2270	2.125
22:00 - 23:00	1	2300	0.043	1	2300	0.261	1	2300	0.304
23:00 - 24:00									
Total Rates:			105.505			105.746			211.251

This section displays the trip rate results based on the selected set of surveys and the selected count type (shown just above the table). It is split by three main columns, representing arrivals trips, departures trips, and total trips (arrivals plus departures). Within each of these main columns are three sub-columns. These display the number of survey days where count data is included (per time period), the average value of the selected trip rate calculation parameter (per time period), and the trip rate result (per time period). Total trip rates (the sum of the column) are also displayed at the foot of the table.

To obtain a trip rate, the average (mean) trip rate parameter value (TRP) is first calculated for all selected survey days that have count data available for the stated time period. The average (mean) number of arrivals, departures or totals (whichever applies) is also calculated (COUNT) for all selected survey days that have count data available for the stated time period. Then, the average count is divided by the average trip rate parameter value, and multiplied by the stated calculation factor (shown just above the table and abbreviated here as FACT). So, the method is: $COUNT/TRP*FACT$. Trip rates are then rounded to 3 decimal places.

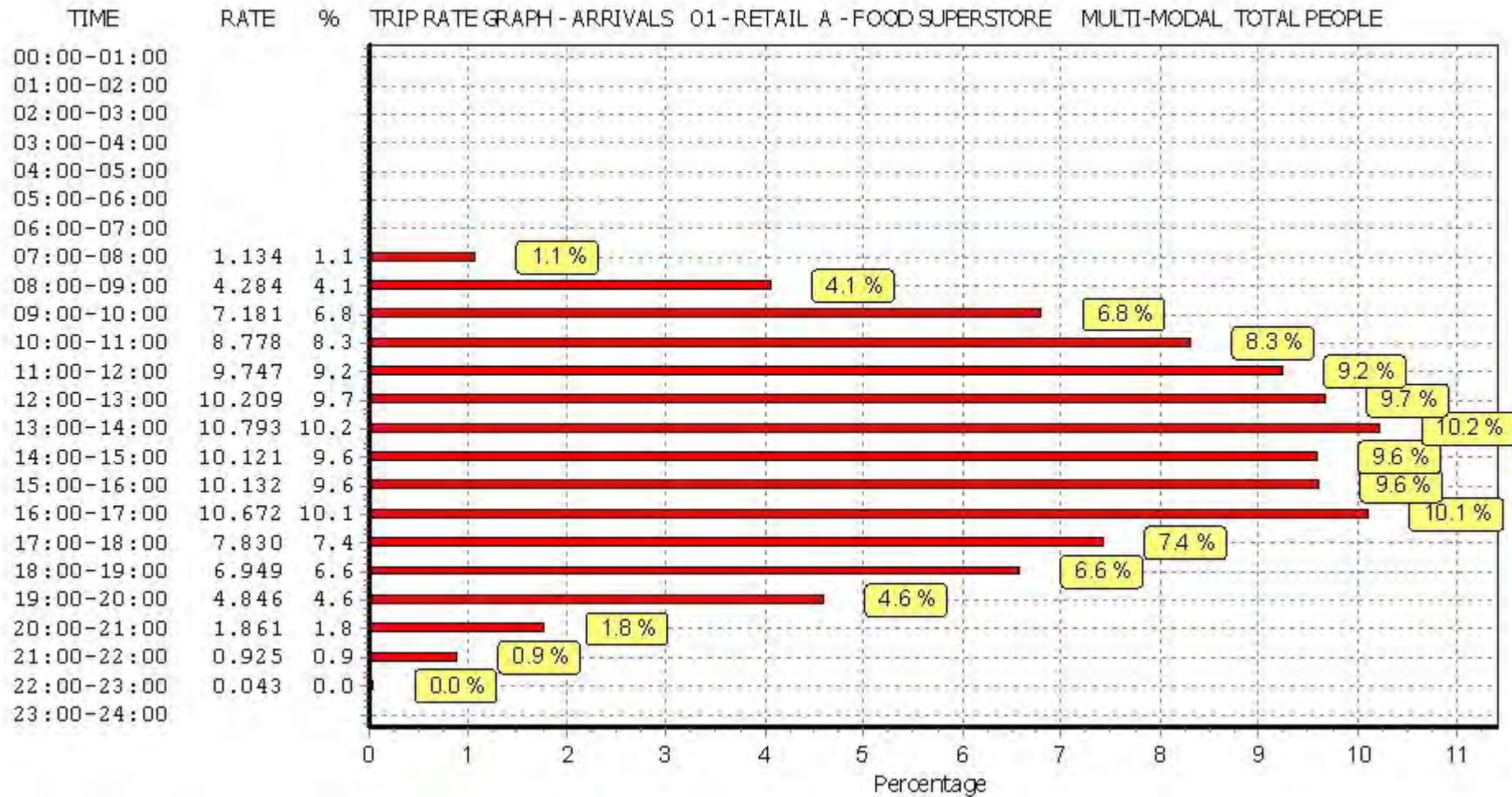

This graph is a visual representation of the trip rate calculation results screen. The same time periods and trip rates are displayed, but in addition there is an additional column showing the percentage of the total trip rate by individual time period, allowing peak periods to be easily identified through observation. Note that the type of count and the selected direction is shown at the top of the graph.

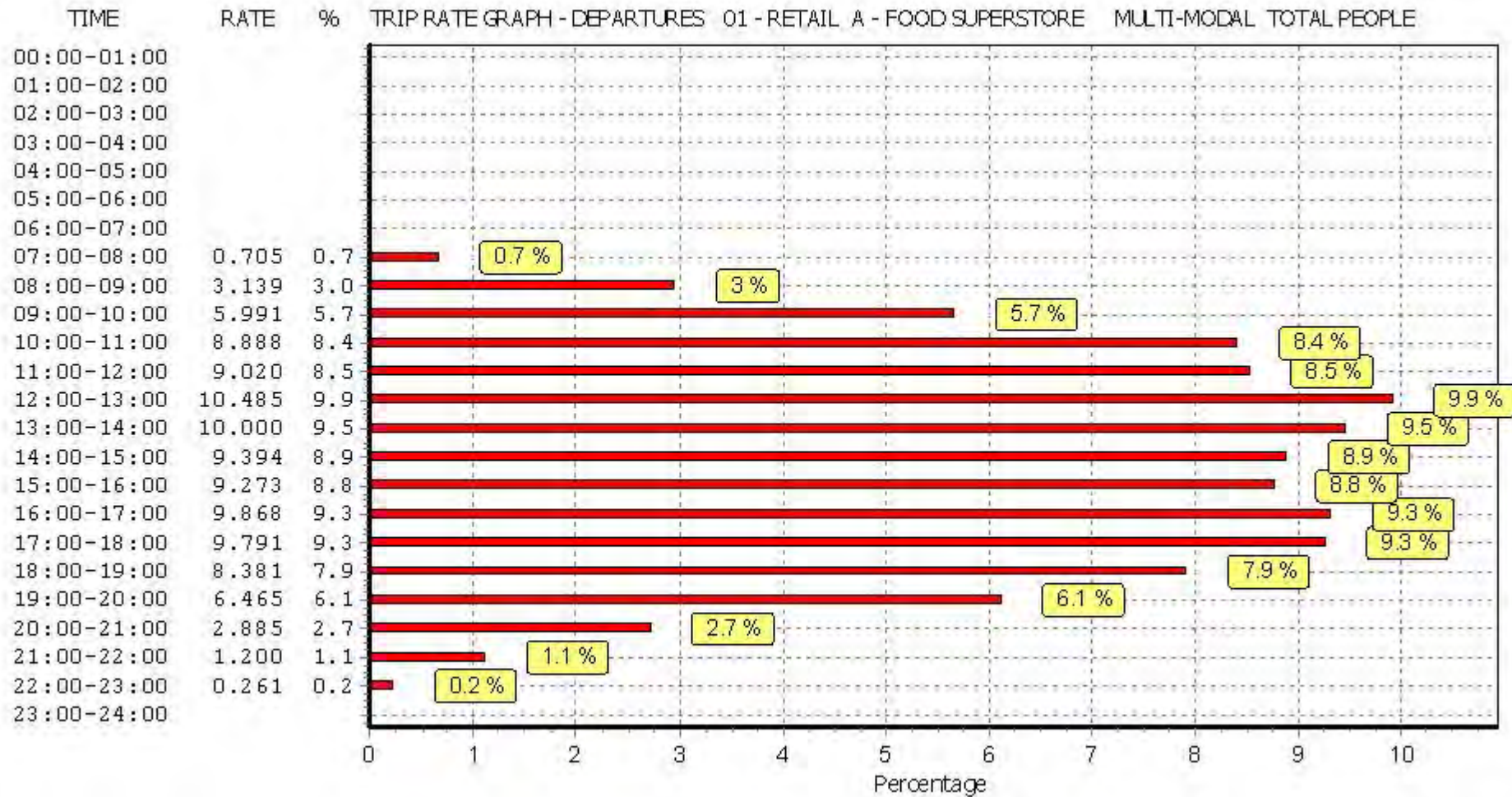

This graph is a visual representation of the trip rate calculation results screen. The same time periods and trip rates are displayed, but in addition there is an additional column showing the percentage of the total trip rate by individual time period, allowing peak periods to be easily identified through observation. Note that the type of count and the selected direction is shown at the top of the graph.

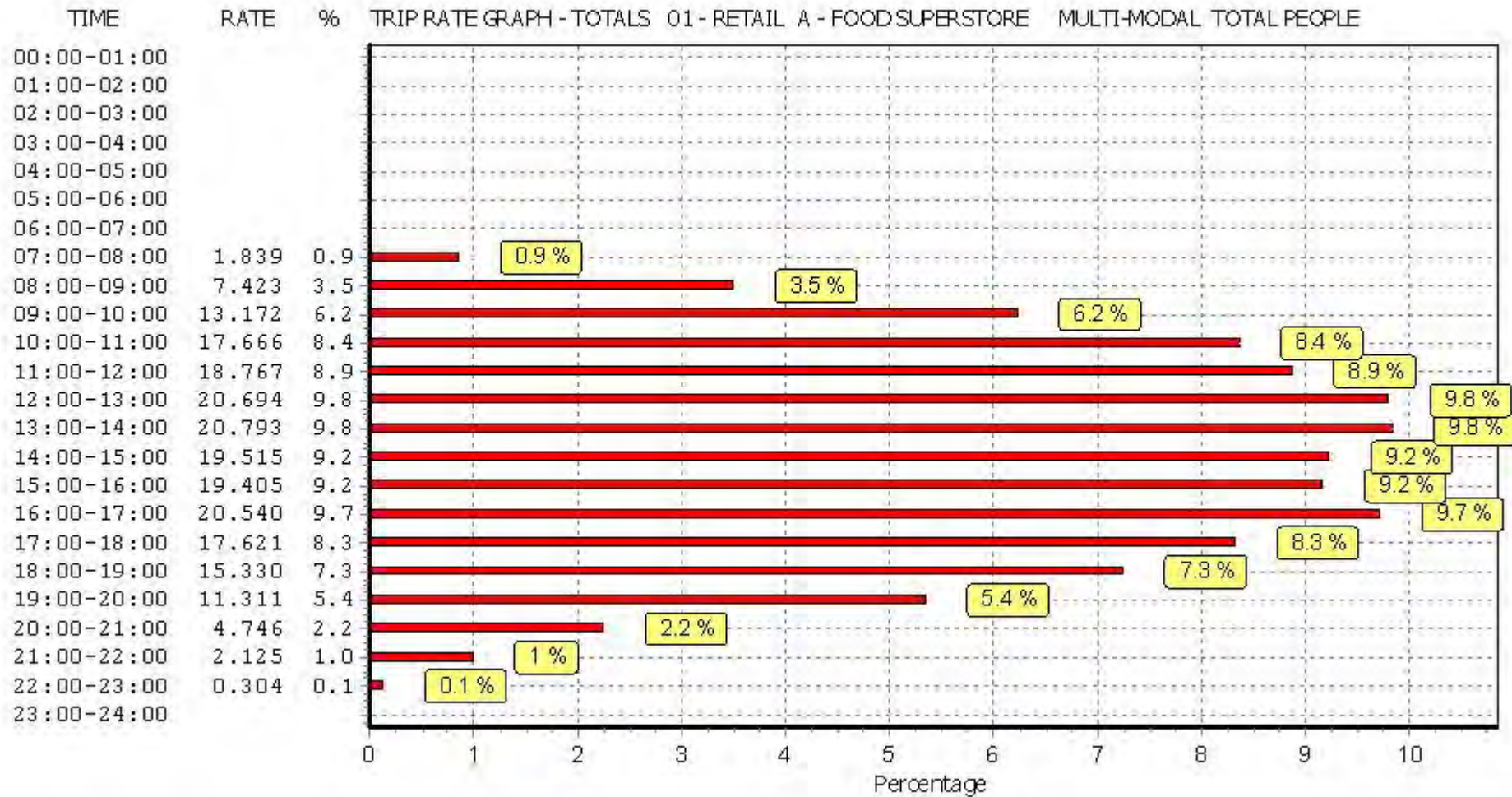

This graph is a visual representation of the trip rate calculation results screen. The same time periods and trip rates are displayed, but in addition there is an additional column showing the percentage of the total trip rate by individual time period, allowing peak periods to be easily identified through observation. Note that the type of count and the selected direction is shown at the top of the graph.

Appendix H – Traffic Flow Diagrams

Key

- | |
|----|
| 10 |
|----|

 Total Vehicles
- | |
|----|
| 10 |
|----|

 HGVs

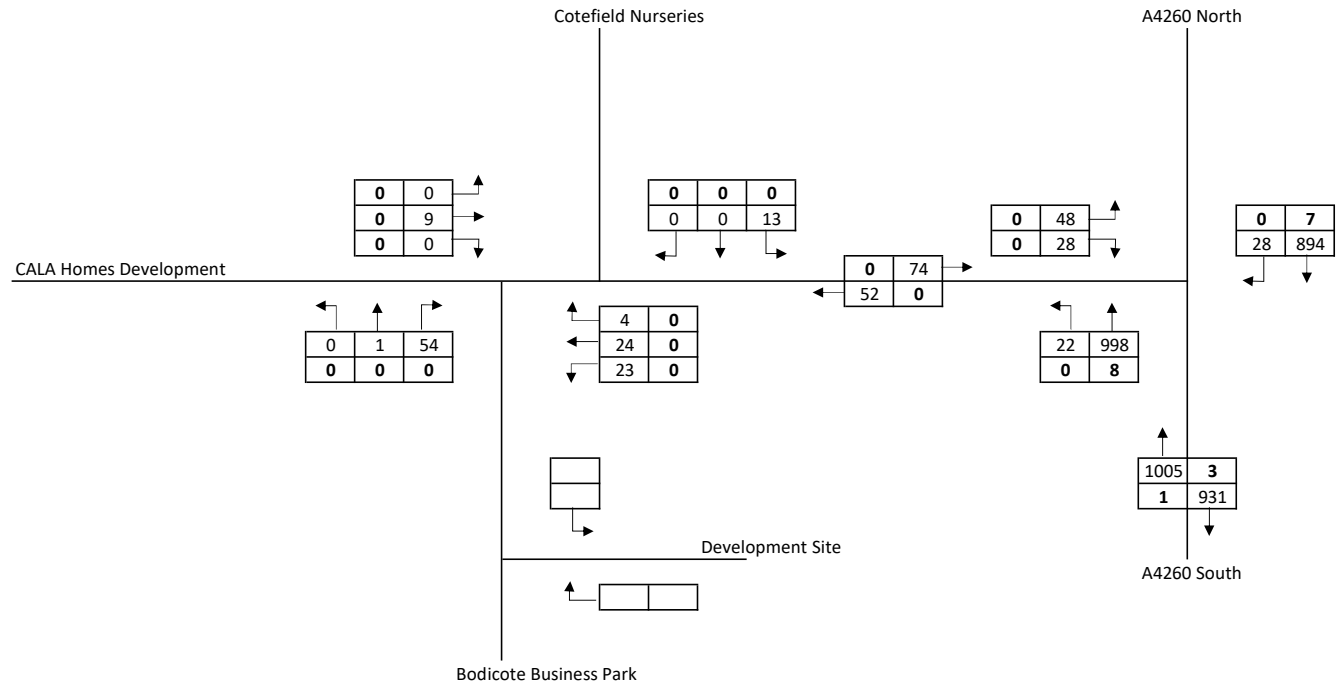

	Project	JNY9860 Cotefield Farm Retail
	Appendix	Appendix H
	Title	2018 Observed Friday 16:00-17:00 Peak Traffic Flows

Key

- | |
|----|
| 10 |
|----|

 Total Vehicles
- | |
|----|
| 10 |
|----|

 HGVs

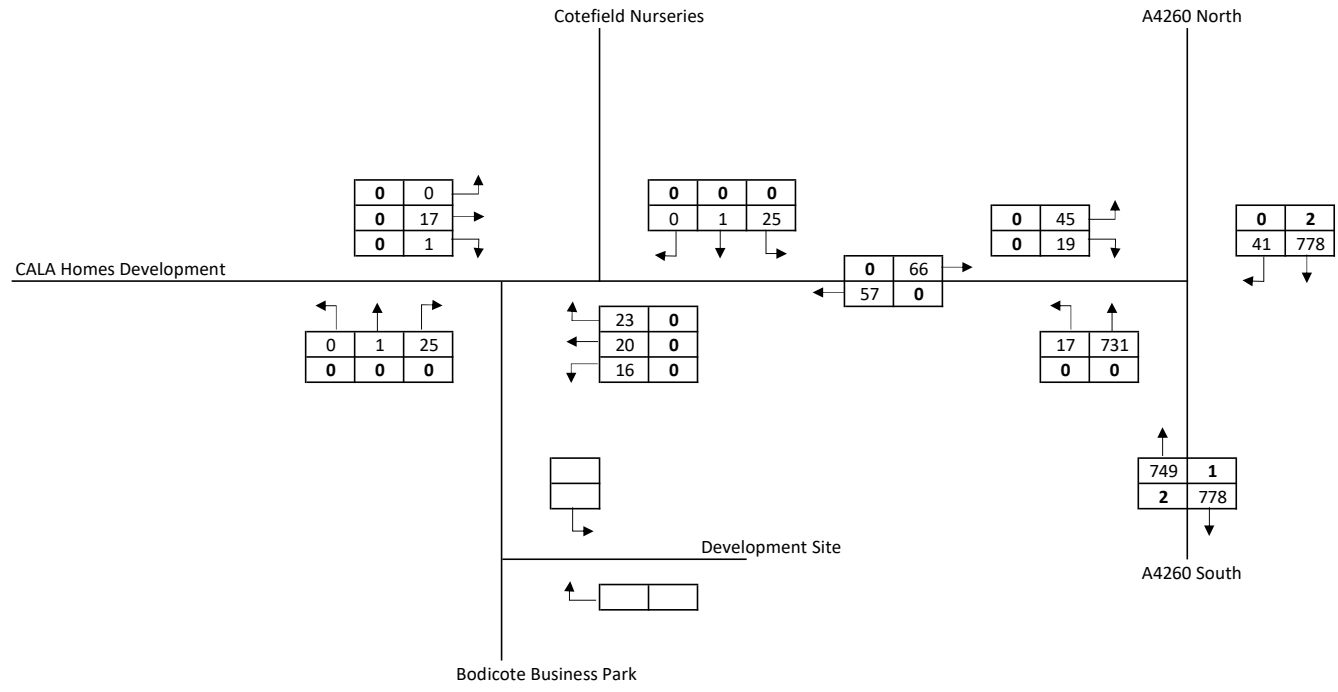

	Project	JNY9860 Cotefield Farm Retail
	Appendix	Appendix H
	Title	2018 Observed Saturday Peak (12:00-13:00) Traffic Flows

Key

- 10 Total Vehicles
- 10 HGVs

Pro rata using MCC survey data

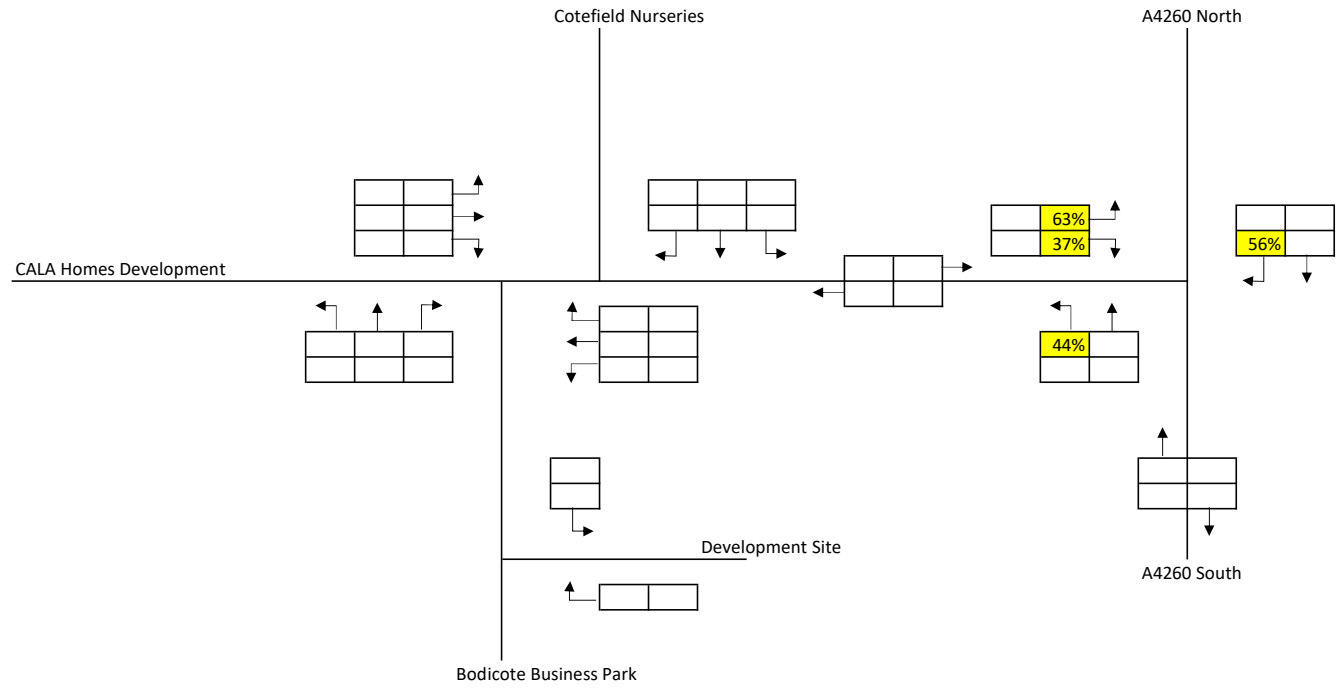

	Project	JNY9860 Cotefield Farm Retail
	Appendix	Appendix H
	Title	(Friday 17:00-18:00) Percentage of Traffic Flows through the Site Access Minor Arm

Key

- 10 Total Vehicles
- 10 HGVs

Pro rata using MCC survey data

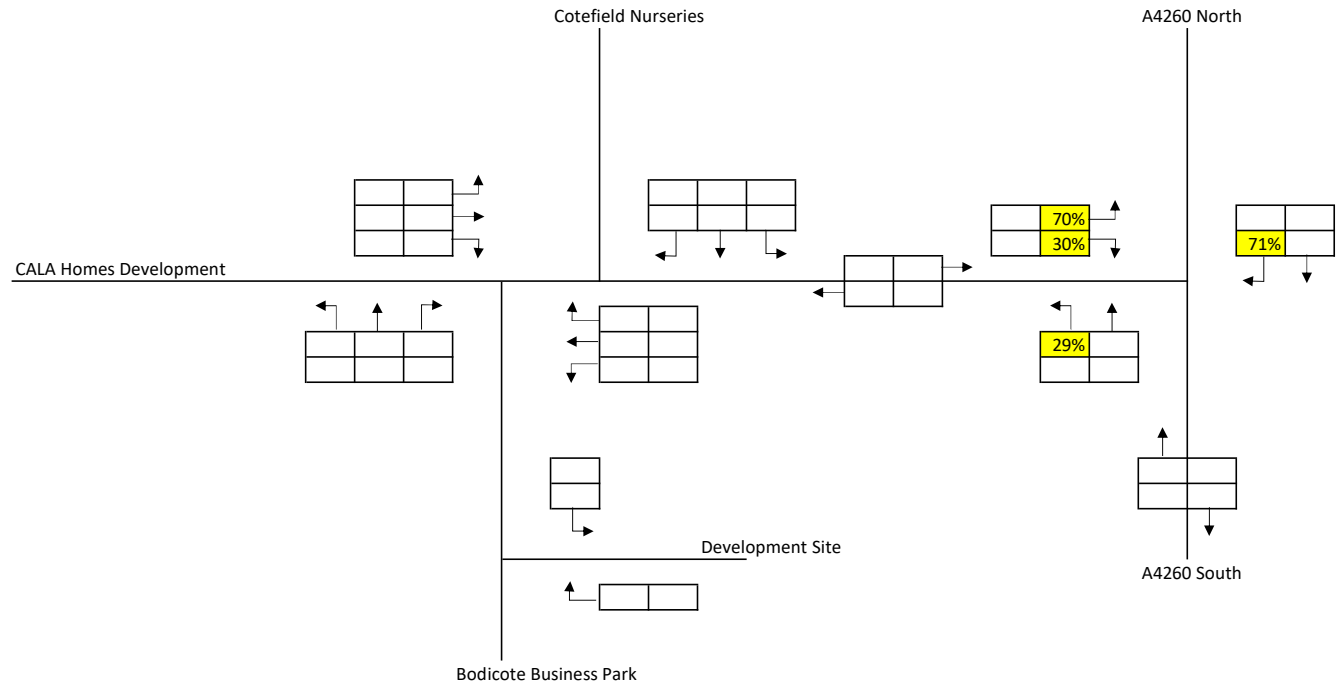

	Project	JNY9860 Cotefield Farm Retail
	Appendix	Appendix H
	Title	(Saturday 12:00-13:00) Percentage of Traffic Flows through the Site Access Minor Arm

Key

- 10 Total Vehicles
- 10 HGVs

Pro rata using survey data

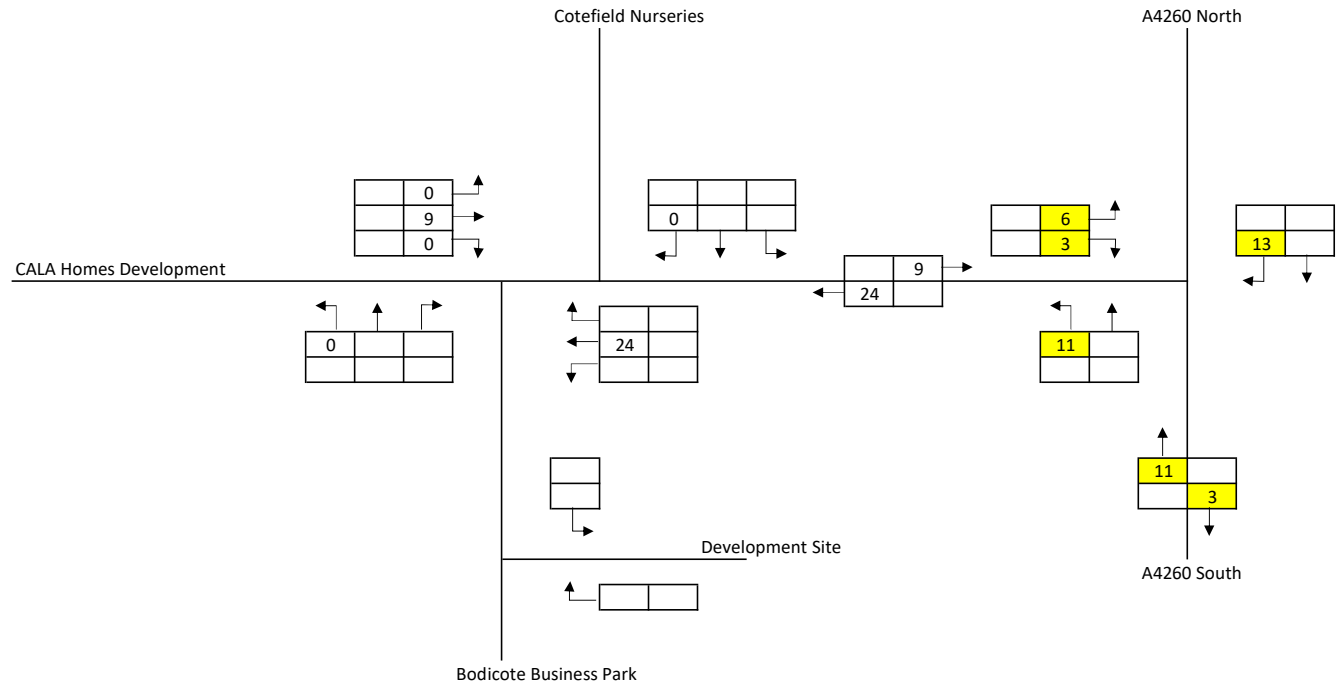

	Project	JNY9860 Cotefield Farm Retail
	Appendix	Appendix H
	Title	2018 Observed Friday 16:00-17:00 Peak Traffic Flows (from CALA Homes development)

Key

- 10 Total Vehicles
- 10 HGVs

Pro rata using survey data

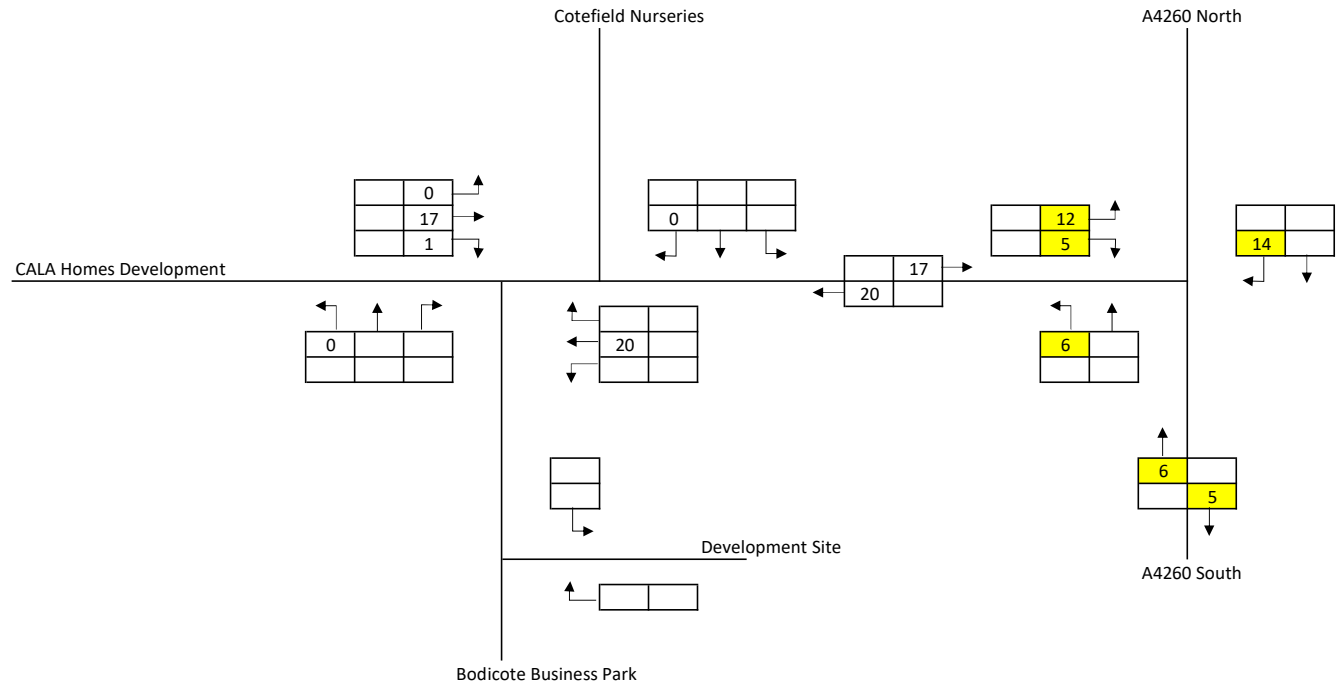

	Project	JNY9860 Cotefield Farm Retail
	Appendix	Appendix H
	Title	2018 Observed Saturday 12:00-13:00 Traffic Flows (from CALA Homes development)

Key

- | |
|----|
| 10 |
|----|

 Total Vehicles
- | |
|----|
| 10 |
|----|

 HGVs

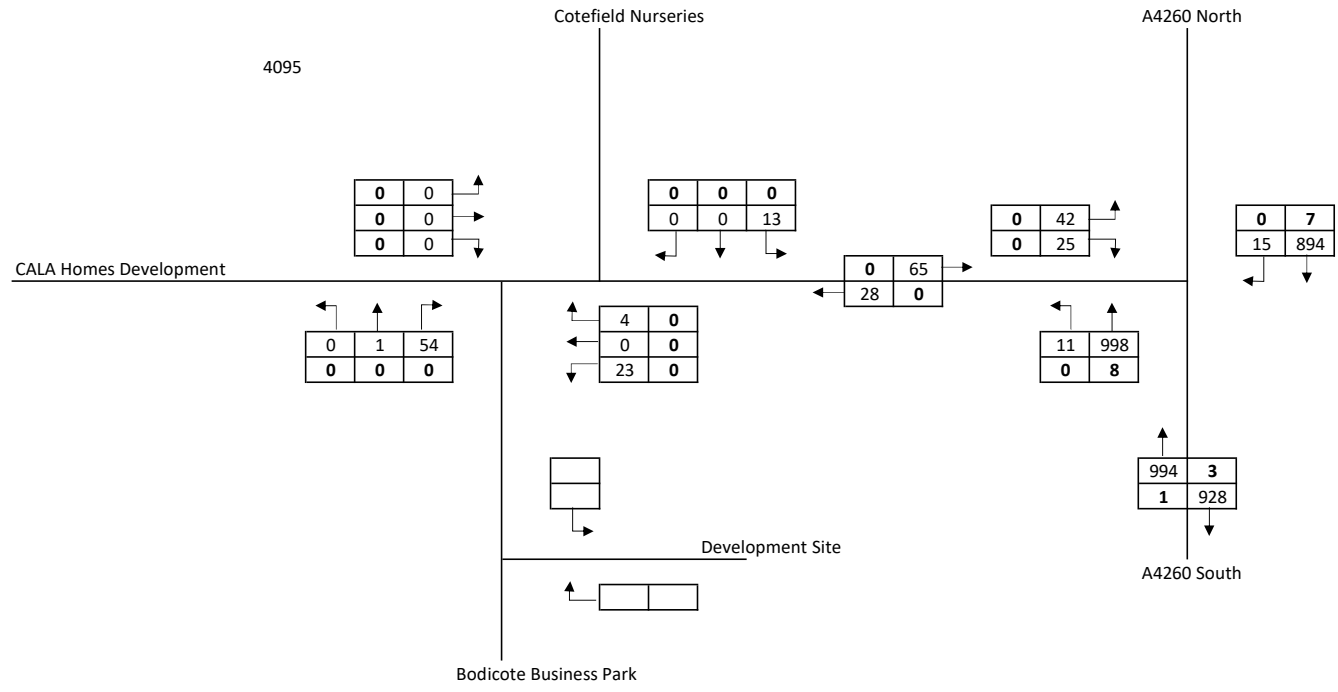

	Project	JNY9860 Cotefield Farm Retail
	Appendix	Appendix H
	Title	2018 Base Friday 16:00-17:00 Peak Traffic Flows

Key

- | |
|----|
| 10 |
|----|

 Total Vehicles
- | |
|----|
| 10 |
|----|

 HGVs

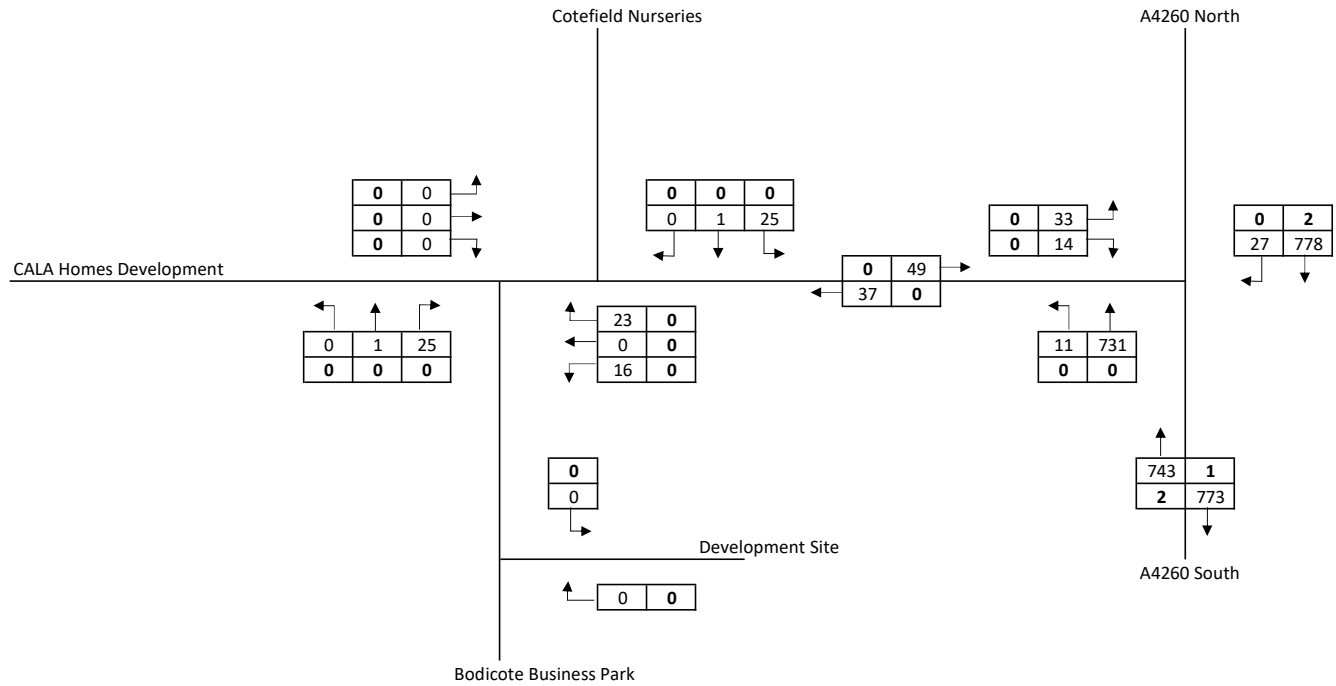

	Project	JNY9860 Cotefield Farm Retail
	Appendix	Appendix H
	Title	2018 Base Saturday 12:00-13:00 Traffic Flows (CALA traffic flows removed)

Key	
10	Total Vehicles
10	HGVs

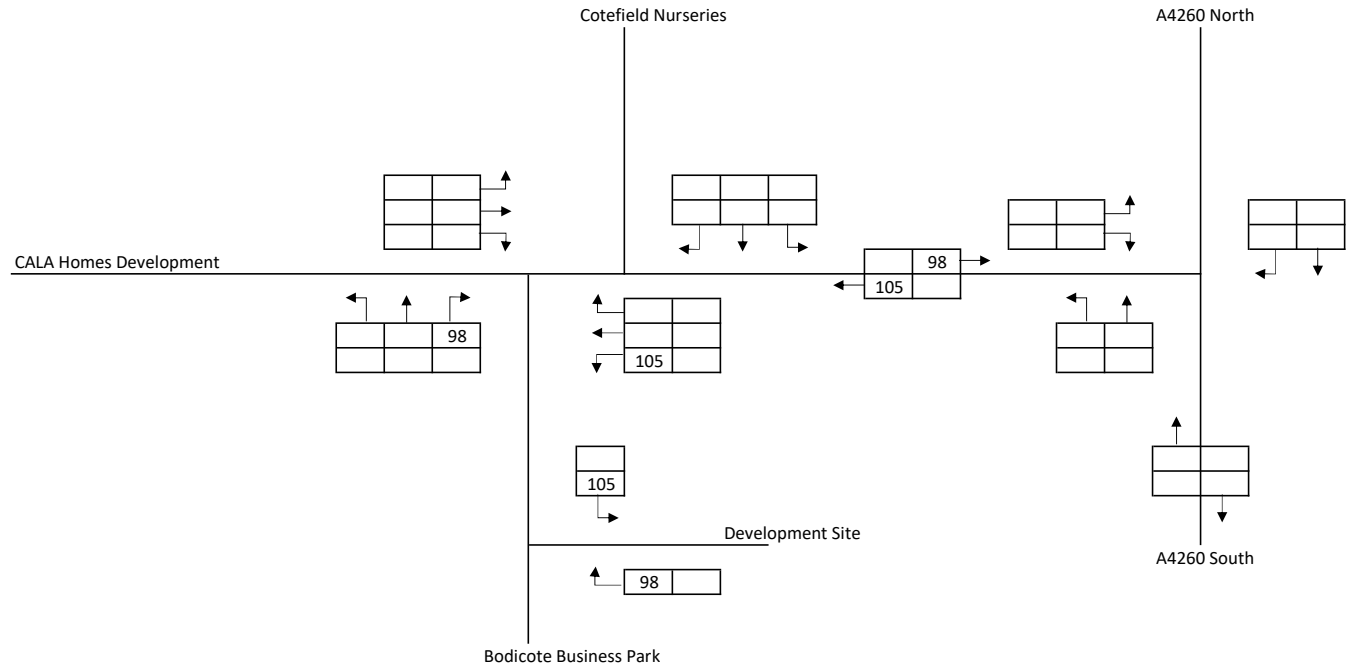

Will assume that 35.0% of vehicle trips are pass-by trips
 Will assume that 55.0% of vehicle trips are transfer trips
 Will assume that 10.0% of vehicle trips are new trips

	Project	JNY9860 Cotefield Farm Retail
	Appendix	Appendix H
	Title	Friday 16:00-17:00 Total Development Traffic Generation

Key	
10	Total Vehicles
10	HGVs

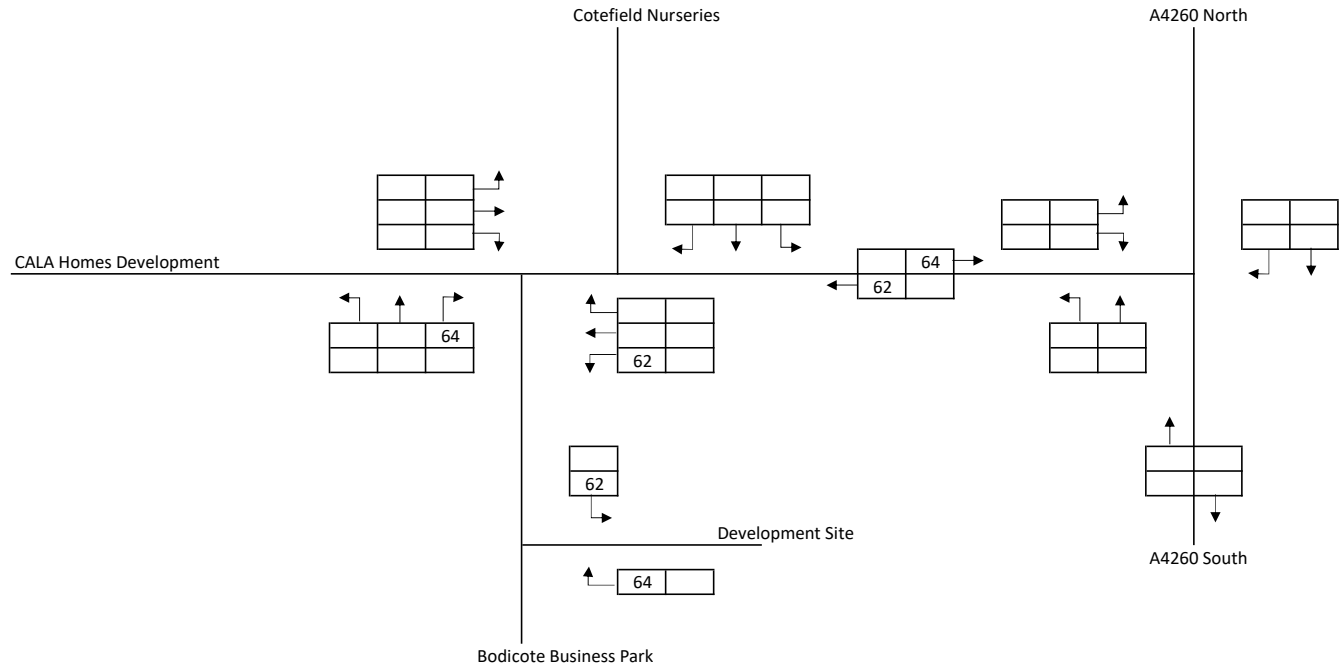

Will assume that 32.6% of vehicle trips are pass-by trips
 Will assume that 57.4% of vehicle trips are transfer trips
 Will assume that 10.0% of vehicle trips are new trips

	Project	JNY9860 Cotefield Farm Retail
	Appendix	Appendix H
	Title	Saturday 12:00-13:00 Total Development Traffic generation

Key

- | |
|----|
| 10 |
|----|

 Total Vehicles
- | |
|----|
| 10 |
|----|

 HGVs

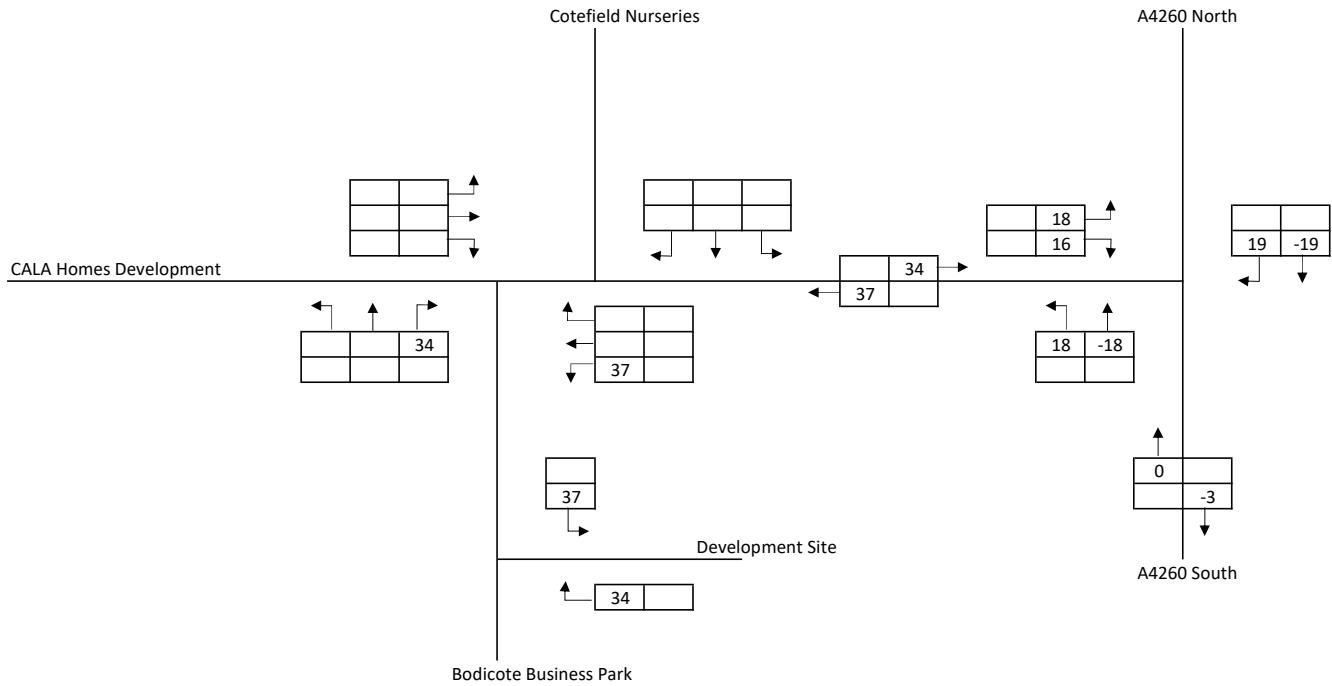

Calculated that 35% of vehicle trips are pass-by trips

	Project	JNY9860 Cotefield Farm Retail
	Appendix	Appendix H
	Title	Friday 17:00-18:00 Development Traffic Passby Flows

Key

- | |
|----|
| 10 |
|----|

 Total Vehicles
- | |
|----|
| 10 |
|----|

 HGVs

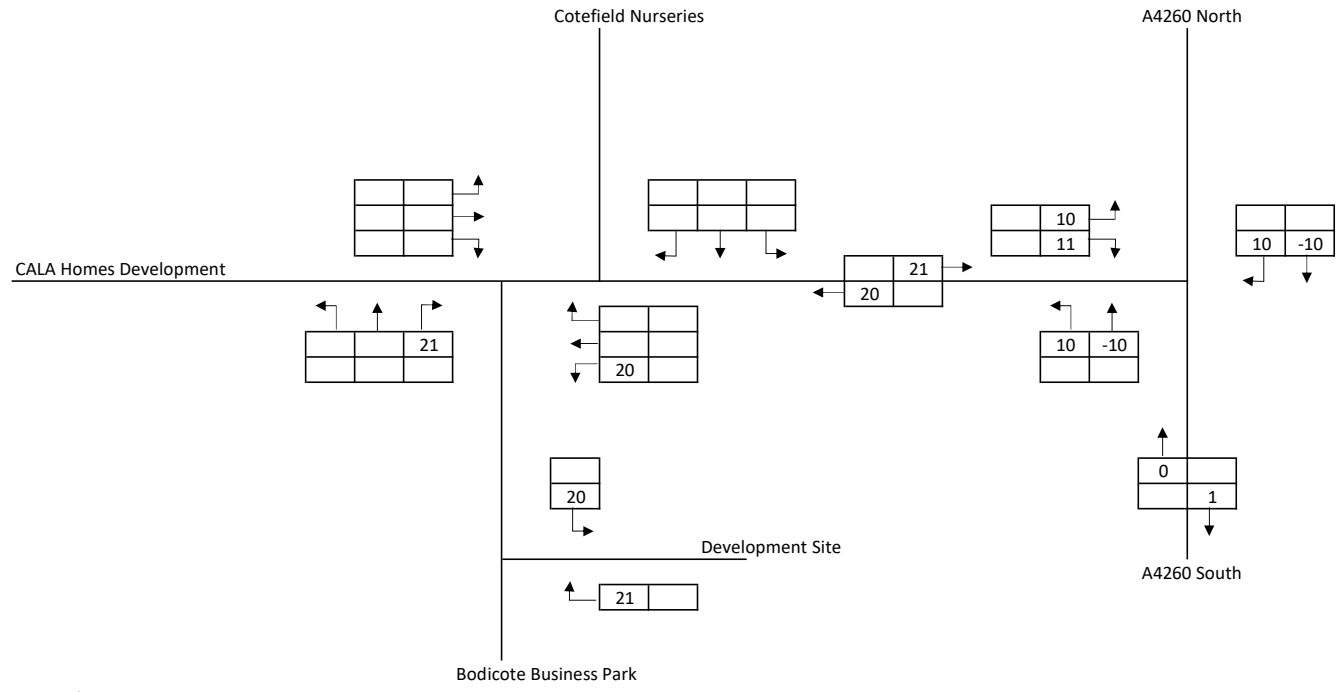

Calculated that 32.6% of vehicle trips are pass-by trips

	Project	JNY9860 Cotefield Farm Retail
	Appendix	Appendix H
	Title	Saturday 12:00-13:00 Development Traffic Passby Flows

Key

- | |
|----|
| 10 |
|----|

 Total Vehicles
- | |
|----|
| 10 |
|----|

 HGVs

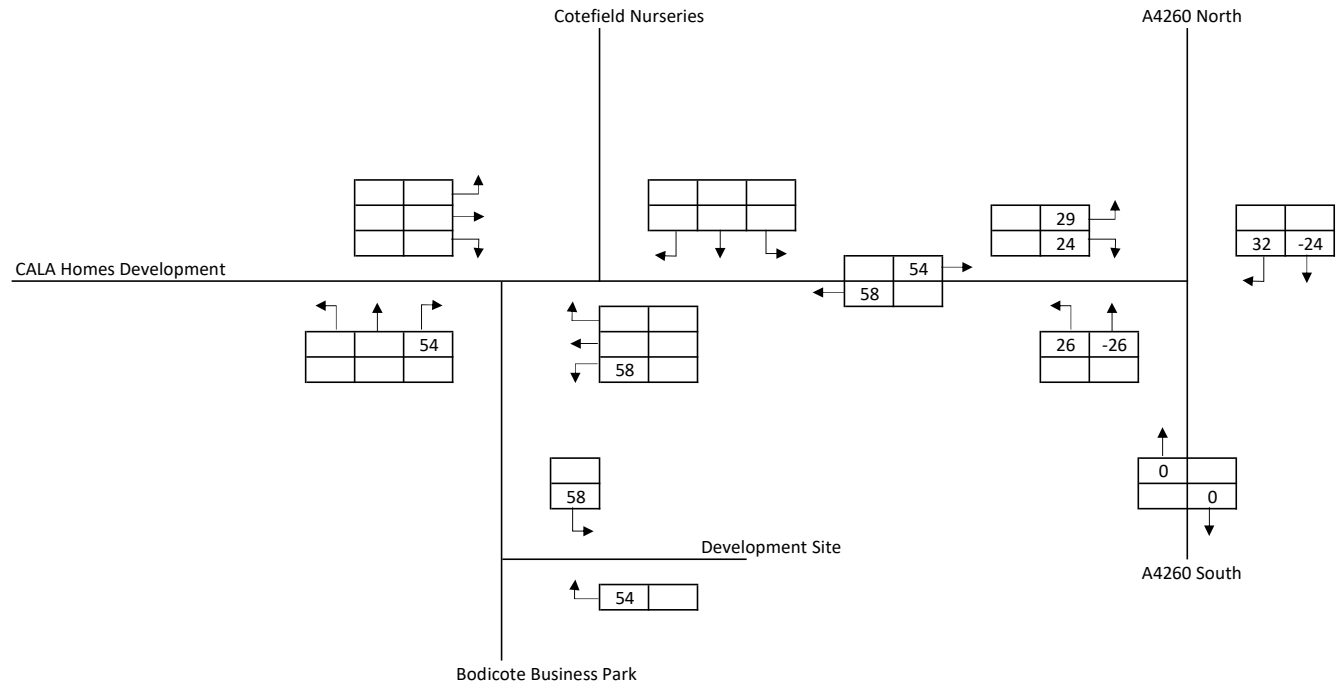

Turning movements through the site access / A4260 Oxford Road junction are calculated using estimate population (2017) data and likely routes to site from each LSOA

	Project	JNY9860 Cotefield Farm Retail
	Appendix	Appendix H
	Title	Friday 17:00-18:00 Development Traffic Transfer Flows

Key

- | |
|----|
| 10 |
|----|

 Total Vehicles
- | |
|----|
| 10 |
|----|

 HGVs

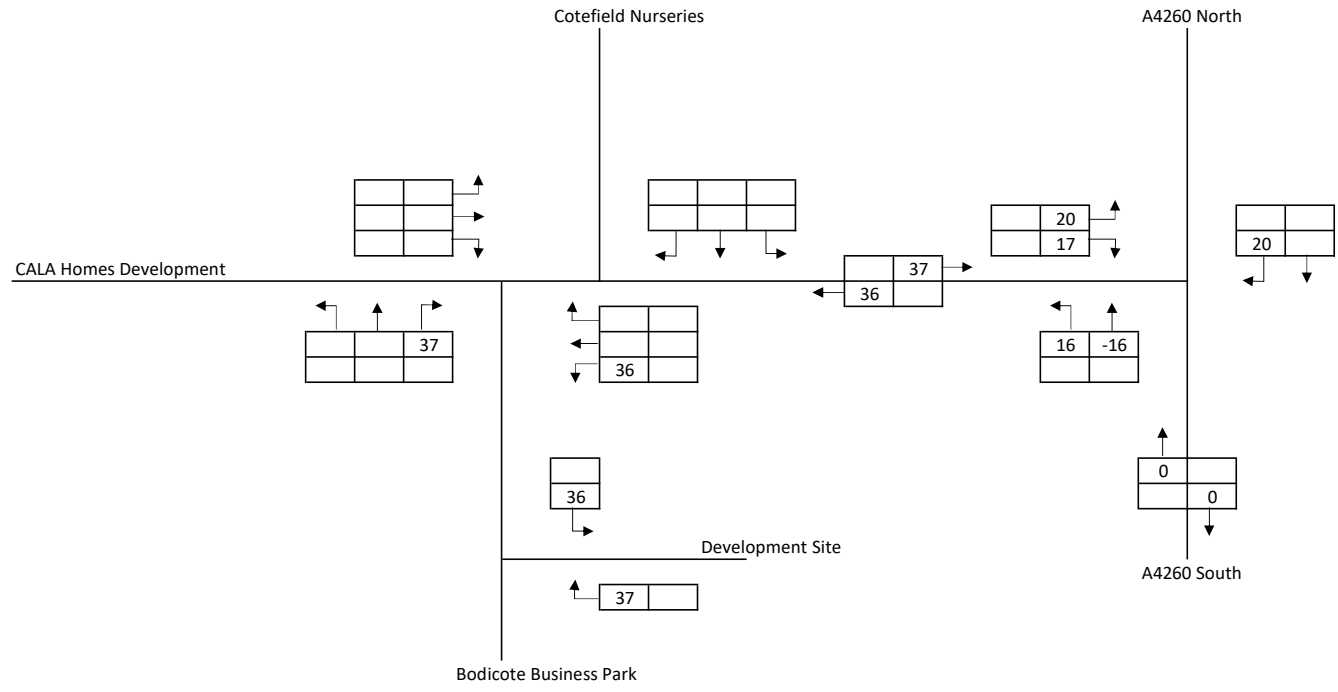

Turning movements through the site access / A4260 Oxford Road junction are calculated using estimate population (2017) data and likely routes to site from each LSOA

	Project	JNY9860 Cotefield Farm Retail
	Appendix	Appendix H
	Title	Saturday 12:00-13:00 Development Traffic Transfer Flows

Key

- | |
|----|
| 10 |
|----|

 Total Vehicles
- | |
|----|
| 10 |
|----|

 HGVs

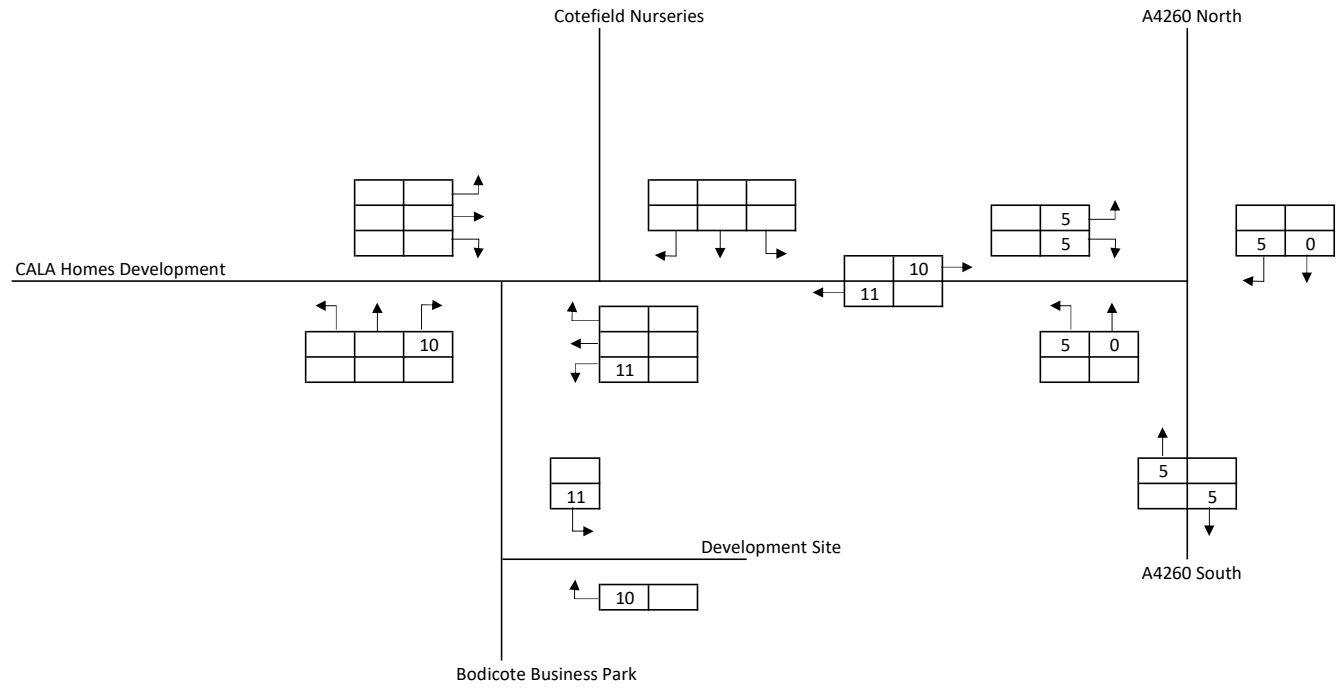

Turning movements through the site access / A4260 Oxford Road junction are calculated using estimate population (2017) data and likely routes to site from each LSOA

	Project	JNY9860 Cotefield Farm Retail
	Appendix	Appendix H
	Title	Friday 17:00-18:00 Development Traffic New Trips

Key

- | |
|----|
| 10 |
|----|

 Total Vehicles
- | |
|----|
| 10 |
|----|

 HGVs

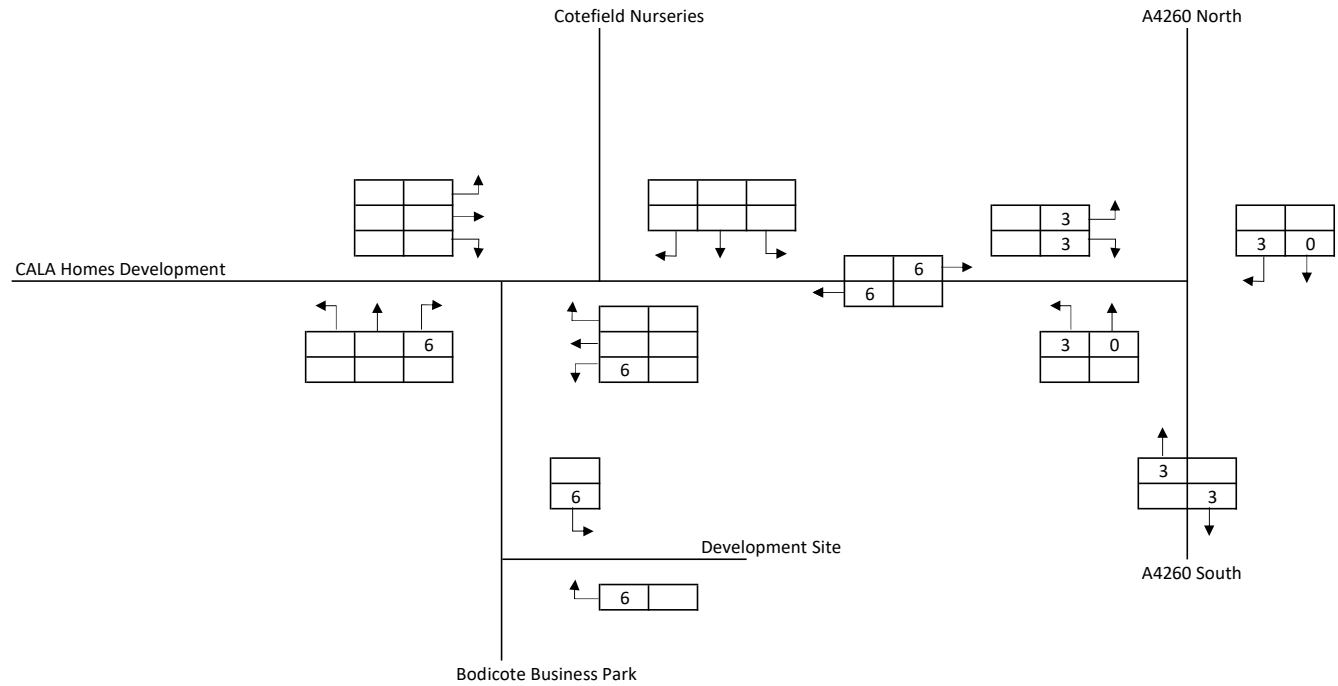

Turning movements through the site access / A4260 Oxford Road junction are calculated using estimate population (2017) data and likely routes to site from each LSOA

	Project	JNY9860 Cotefield Farm Retail
	Appendix	Appendix H
	Title	Saturday 12:00-13:00 Development Traffic New trips

Key

10 Total Vehicles

10 HGVs

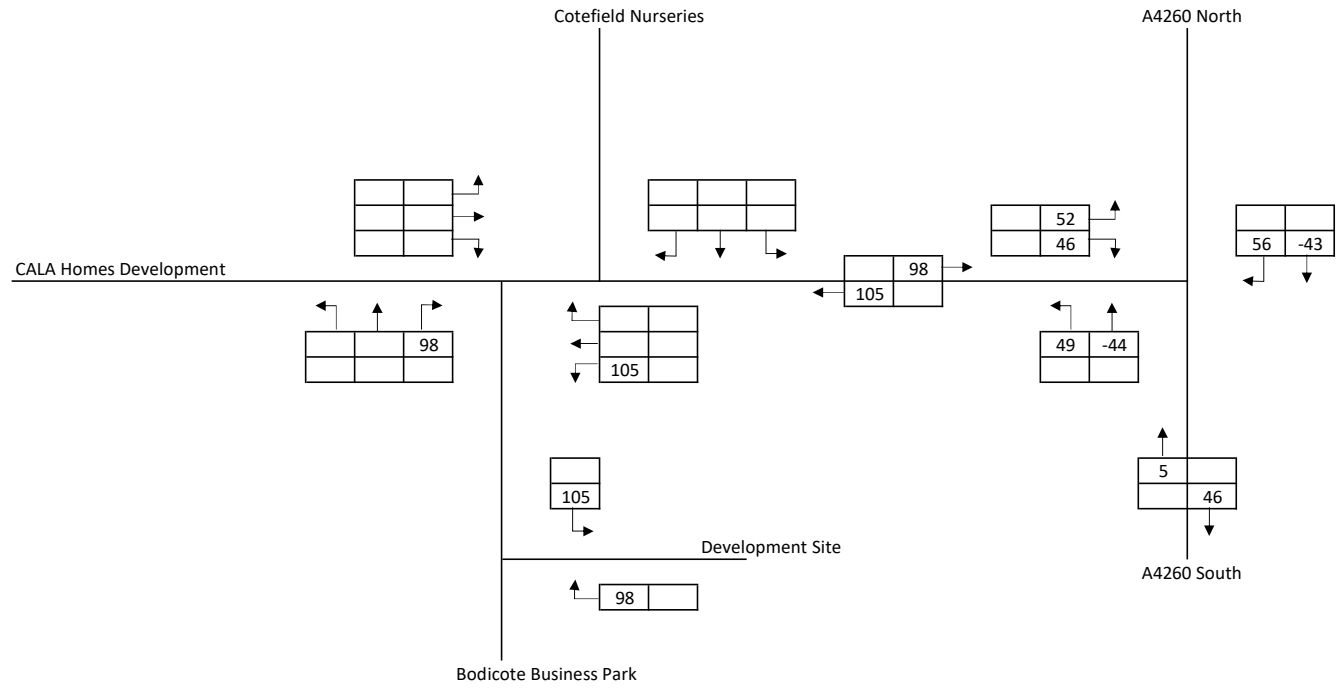

	Project	JNY9860 Cotefield Farm Retail
	Appendix	Appendix H
	Title	Friday 17:00-18:00 Development Traffic Total (Pass-by, Transfer and New Trips)

Key

- | |
|----|
| 10 |
|----|

 Total Vehicles
- | |
|----|
| 10 |
|----|

 HGVs

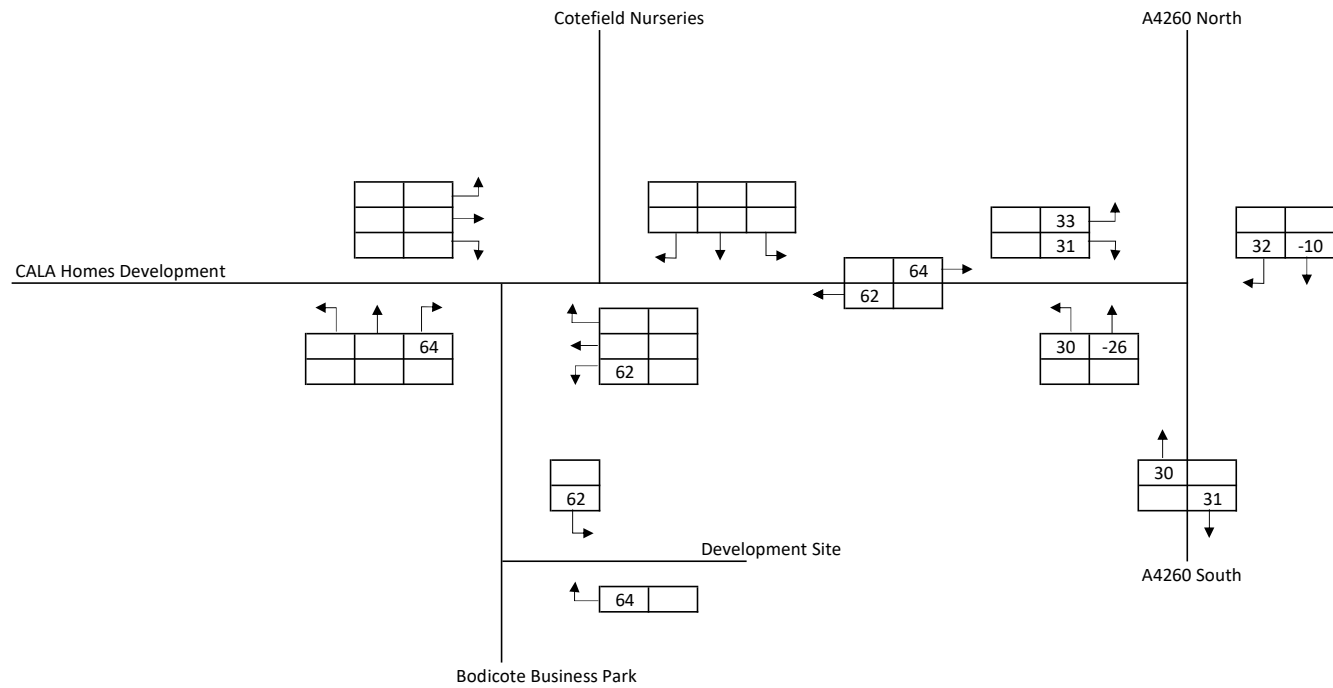

	Project	JNY9860 Cotefield Farm Retail
	Appendix	Appendix H
	Title	Saturday 12:00-13:00 Development Traffic Total (Pass-by, Transfer and New Trips)

Key

- 10 Total Vehicles
- 10 HGVs

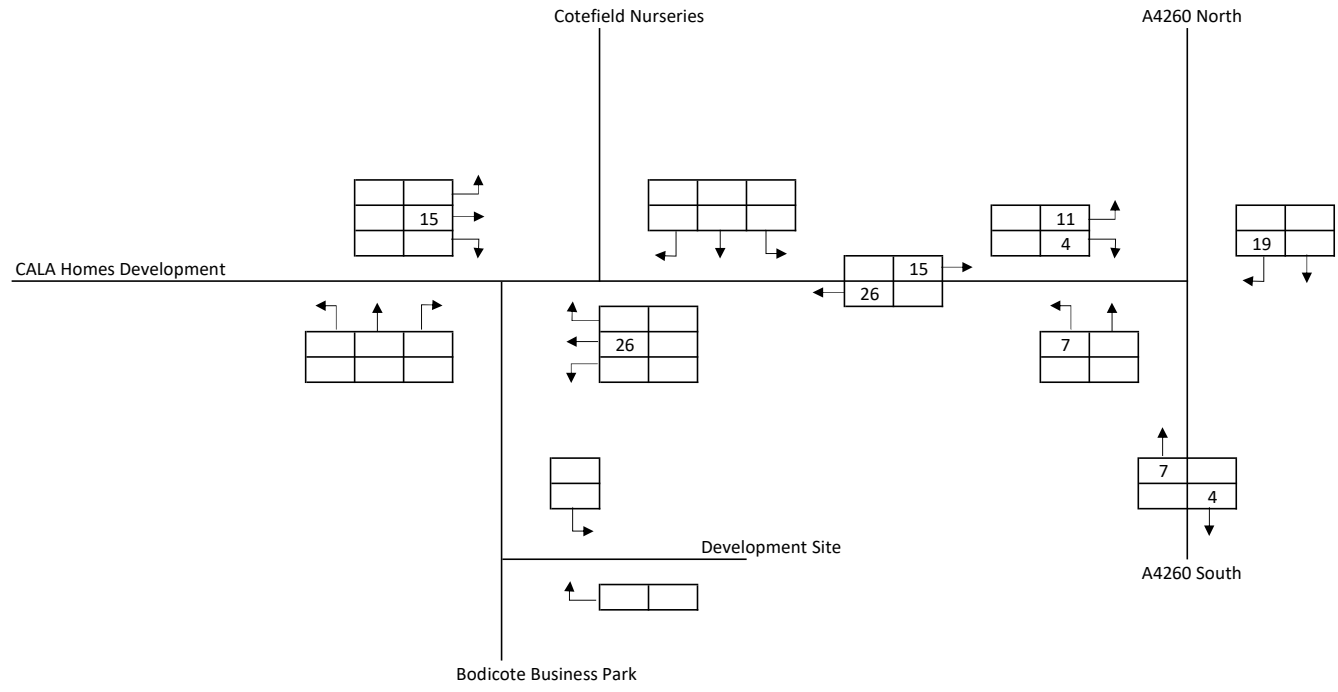

Traffic Flows taken from JNY8146 Traffic Flow Models
 Traffic flows factored from TRICS 17:00-18:00 data to 16:00-17:00 Traffic Flows, and reduced by 10% in line with travel plan targets

	Project	JNY9860 Cotefield Farm Retail
	Appendix	Appendix H
	Title	Friday CALA Homes Friday PM Traffic Flows

Key

- 10 Total Vehicles
- 10 HGVs

Pro-rata using survey data

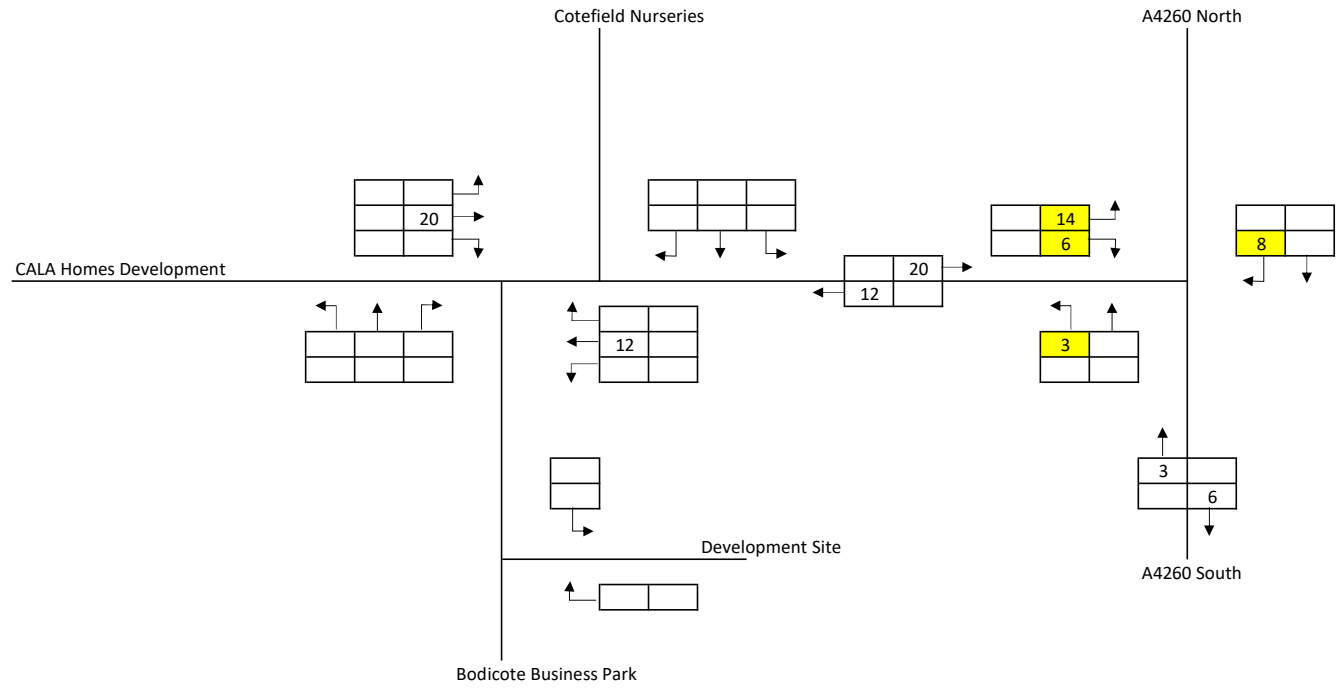

Calculated from TRICS Saturday sites

	Project	JNY9860 Cotefield Farm Retail
	Appendix	Appendix H
	Title	Saturday CALA Homes 12:00-13:00 Traffic Flows

Key

- 10 Total Vehicles
- 10 HGVs

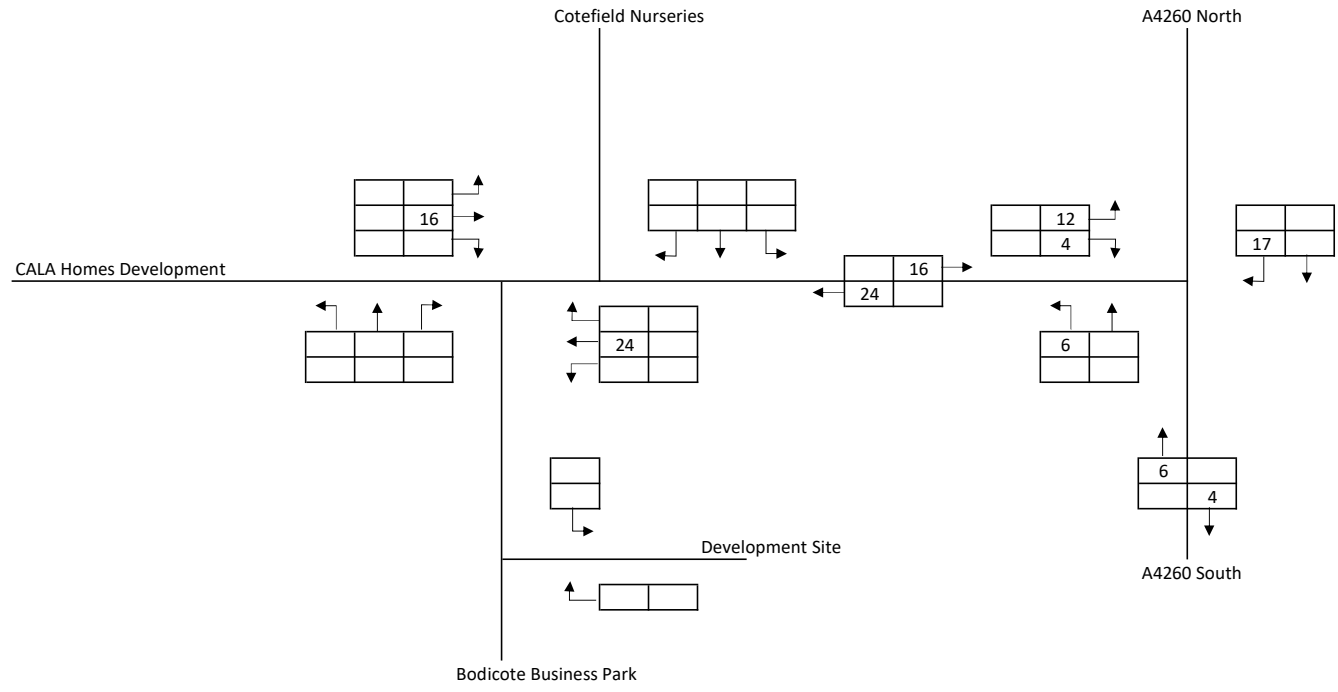

Taken from JNY8146 Traffic Flow Models
 Traffic flows factored from TRICS 17:00-18:00 data to 16:00-17:00 Traffic Flows, and reduced by 10% in line with travel plan targets

	Project	JNY9860 Cotefield Farm Retail
	Appendix	Appendix H
	Title	JNY8146 Land South of Bodicote Weekday PM Traffic Flows

Key

- 10 Total Vehicles
- 10 HGVs

Pro-rata using survey data

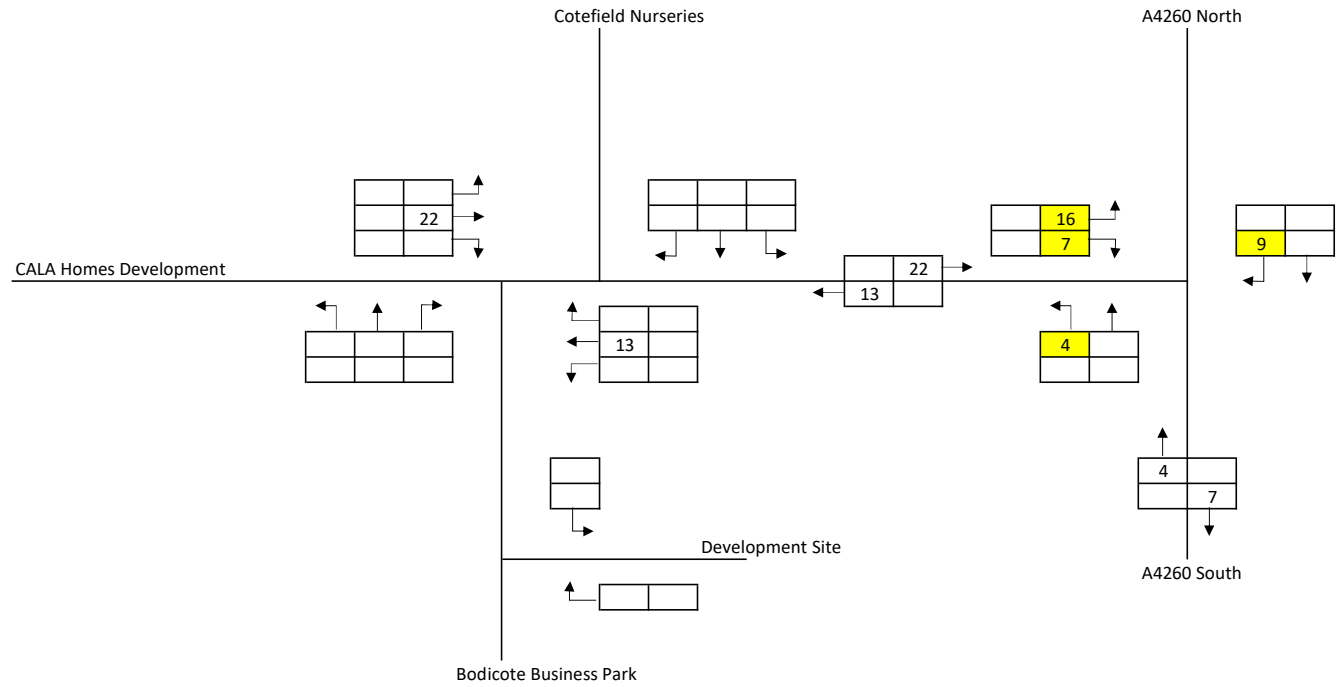

Calculated using available TRICS data: the saturday vehicle trips were factored using (Friday TRICS 1700-1800 trip rate / Saturday TRICS 1200-1300 trip rate)* number of Friday vehicles

	Project	JNY9860 Cotefield Farm Retail
	Appendix	Appendix H
	Title	JNY8146 Land South of Bodicote Saturday 12:00-13:00 Traffic Flows

Key

10	Total Vehicles
10	HGVs

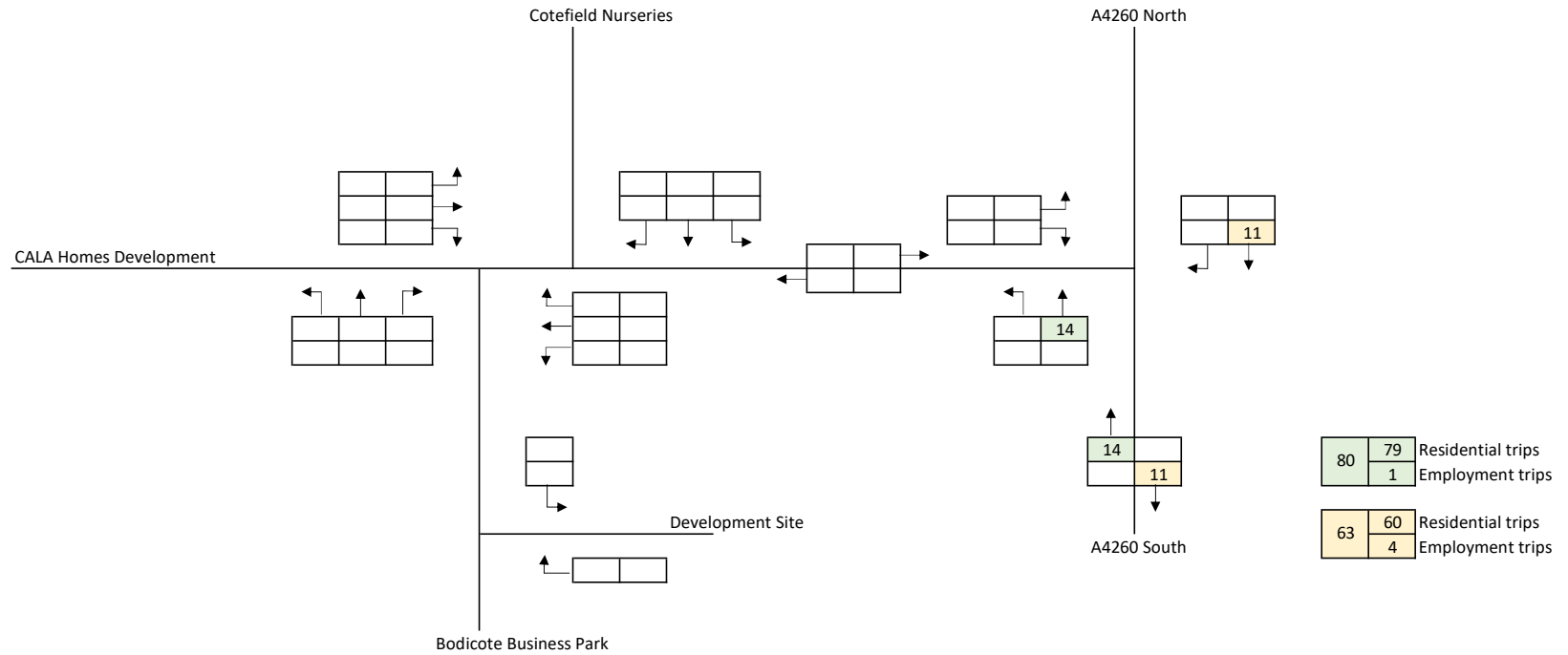

Taken from Bankside Phase 2 Cumulative Impact Assessment

Bankside is under construction with a substantial number of units occupied. A reserved matters application for 215 dwellings is under construction. It is assumed of the initial 1070 dwellings, 20% are yet to be occupied.

Traffic flows factored from TRICS 17:00-18:00 data to 16:00-17:00 Traffic Flows

	Project	JNY9860 Cotefield Farm Retail
	Appendix	Appendix H
	Title	05/01337/OUT Bankside Friday PM Flows

Key

- | | |
|----|----------------|
| 10 | Total Vehicles |
|----|----------------|
- | | |
|----|------|
| 10 | HGVs |
|----|------|

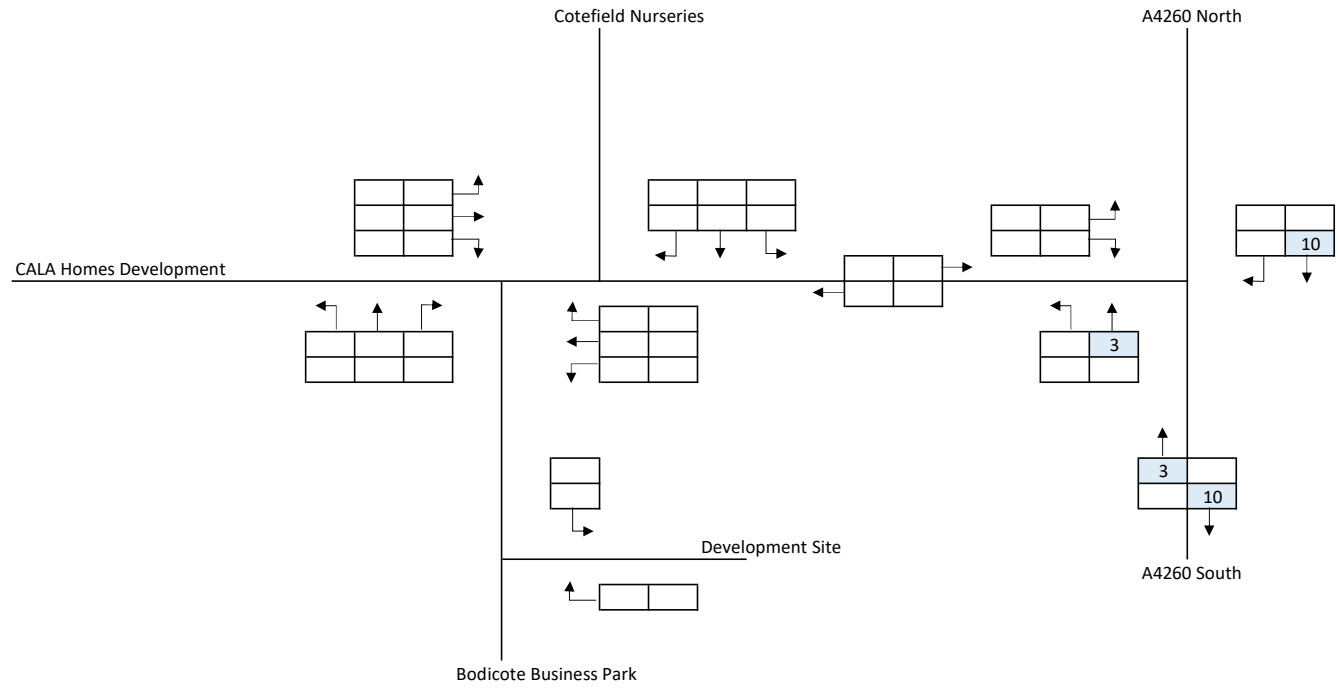

Calculated using available TRICS data: the saturday vehicle trips were factored using (Friday TRICS 1700-1800 trip rate / Saturday TRICS 1200-1300 trip rate)* number of Friday vehicles
 Employment trips account for less than 10% of the total; therefore the Friday trips (including residential and employment) were factored against the Saturday residential trip rate to enable a worst case scanario.
 Bankside is under construction with a substantial number of units occupied. A reserved matters application for 215 dwellings is under construction. It is assumed of the initial 1070 dwellings, 20% are yet to be occupied.

	Project	JNY9860 Cotefield Farm Retail
	Appendix	Appendix H
	Title	05/01337/OUT Bankside 1 Saturday Peak

Key

- 10 Total Vehicles
- 10 HGVs

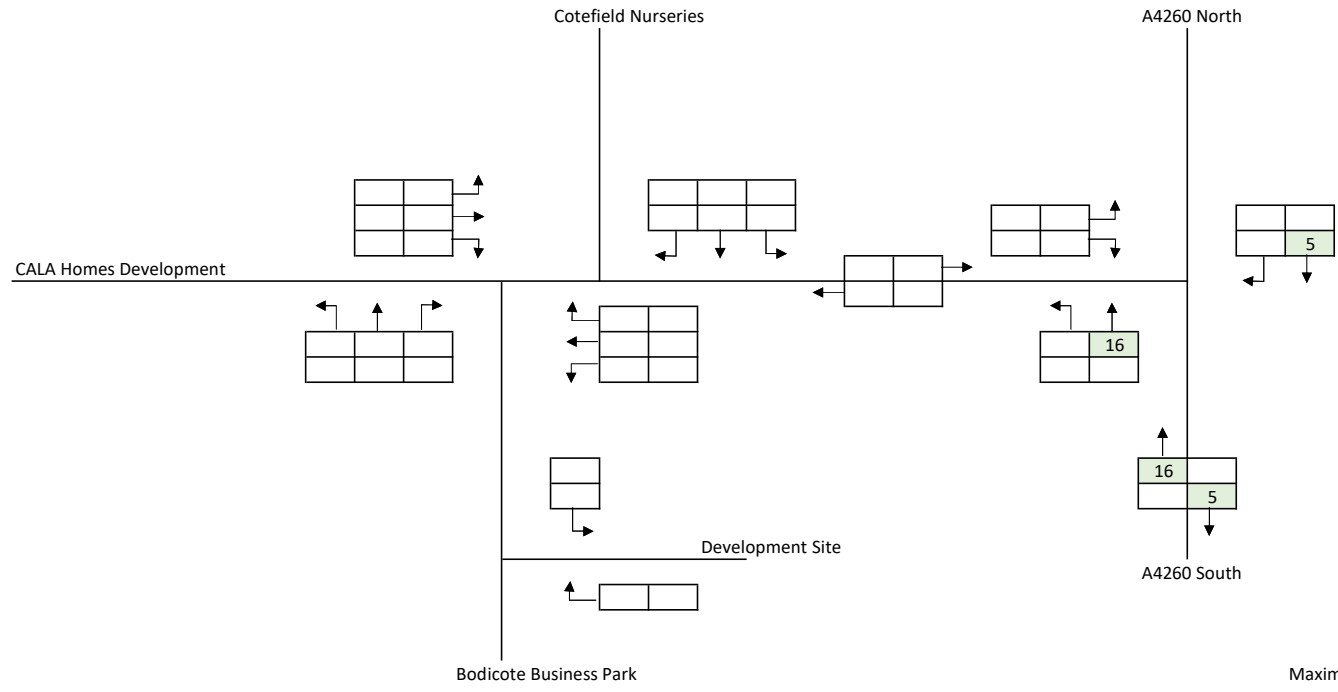

Travel Plan Targets

Maximum target peak hour trip rate of 0.537
 Peak Hour (PM) trip rate of 0.658 used in report
 Multiplication factor of 82%

Taken from Figure B6 from Transport Assessment

 Values are in PCUs

Traffic flows factored from TRICS 17:00-18:00 data to 16:00-17:00 Traffic Flows, and reduced in line with Travel Plan targets

	Project	JNY9860 Cotefield Farm Retail
	Appendix	Appendix H
	Title	15/01326/OUT White Post Road Friday PM peak Traffic Flows

Key

- 10 Total Vehicles
- 10 HGVs

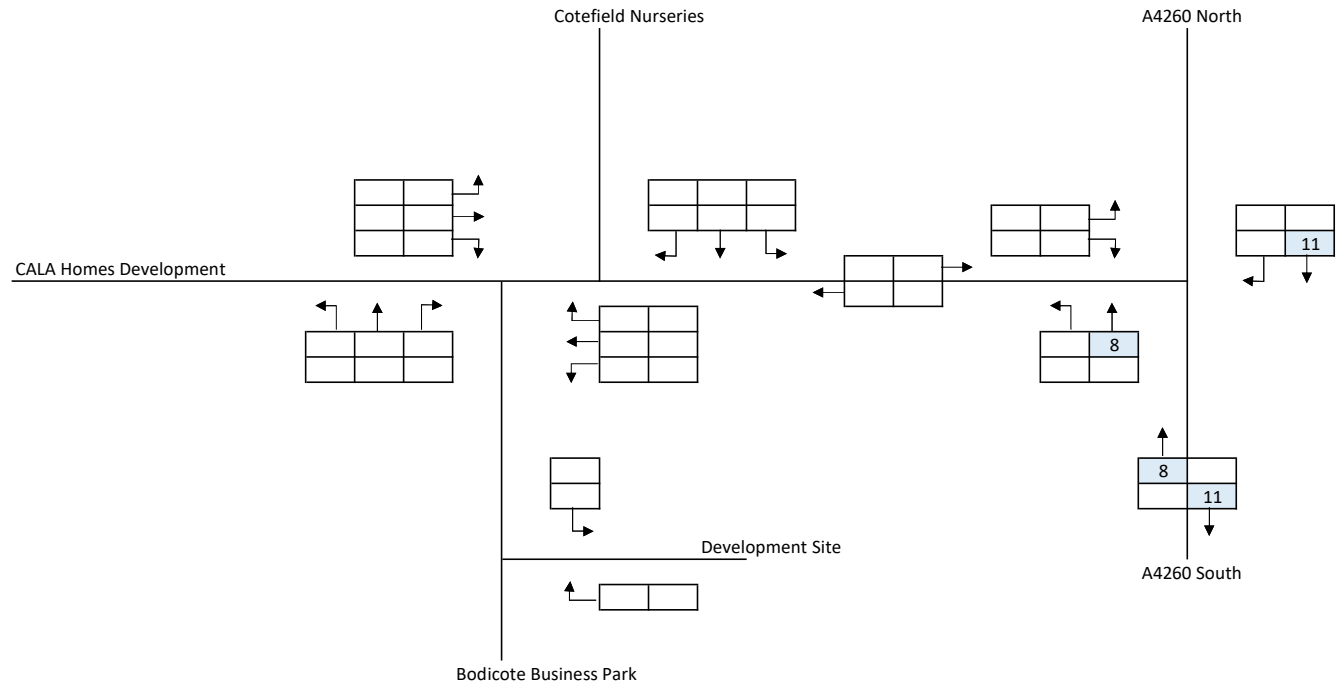

Calculated using available TRICS data

 The saturday vehicle trips were factored using (Friday TRICS 1700-1800 trip rate / Saturday TRICS 1200-1300 trip rate)* number of Friday vehicles

	Project	JNY9860 Cotefield Farm Retail
	Appendix	Appendix H
	Title	15/01326/OUT White Post Road Saturday 12:00-13:00 Traffic Flows

Key

10 Total Vehicles

10 HGVs

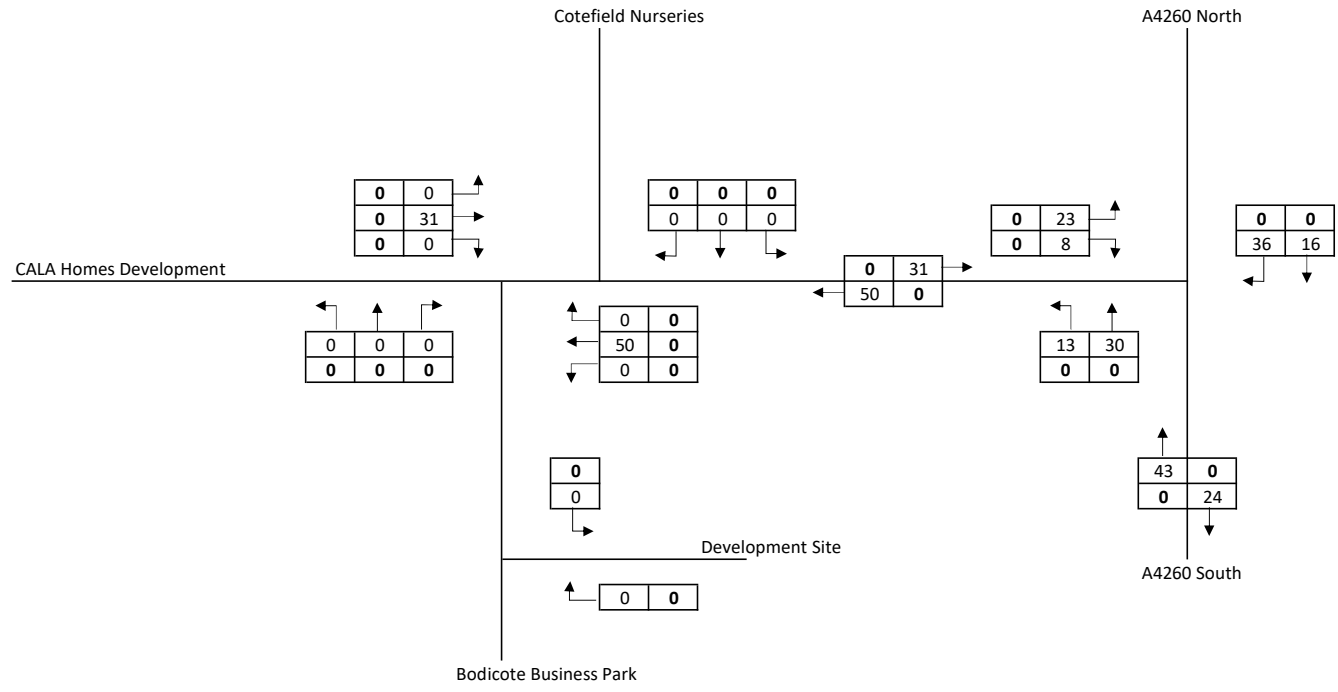

	Project	JNY9860 Cotefield Farm Retail
	Appendix	Appendix H
	Title	2024 Friday PM Committed Flows

Key

10 Total Vehicles

10 HGVs

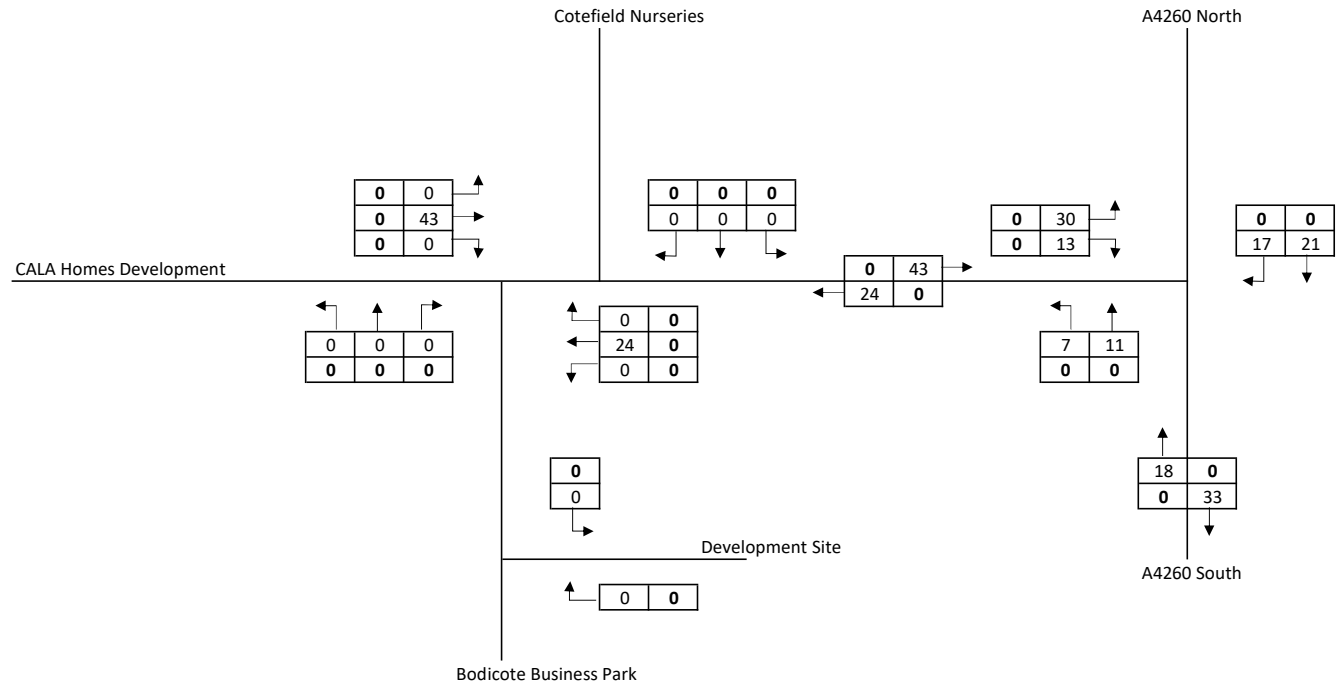

	Project	JNY9860 Cotefield Farm Retail
	Appendix	Appendix H
	Title	2024 Saturday Peak Committed Flows

Key	
10	Total Vehicles
10	HGVs

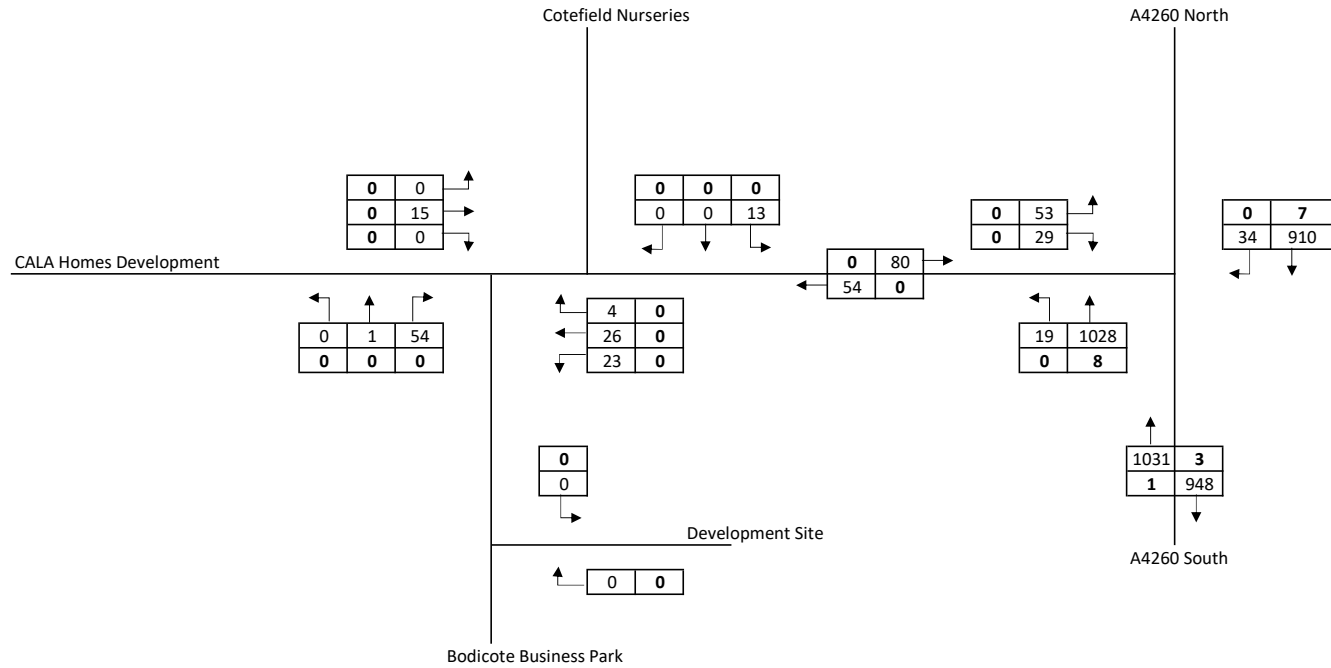

	Project	JNY9860 Cotefield Farm Retail
	Appendix	Appendix H
	Title	2024 Interim Baseline Friday 16:00-17:00 Traffic Flows

Key

10 Total Vehicles

10 HGVs

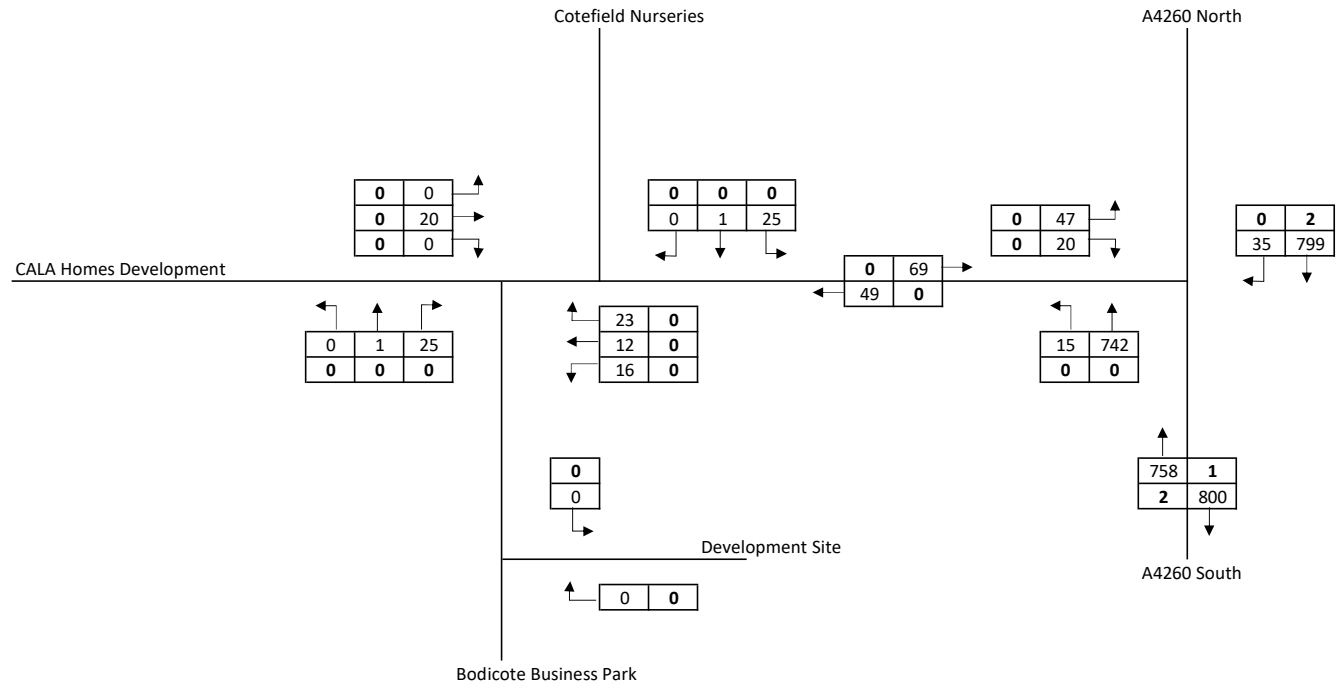

	Project	JNY9860 Cotefield Farm Retail
	Appendix	Appendix H
	Title	2024 Interim Baseline Saturday 12:00-13:00 Traffic Flows

Key

- | |
|----|
| 10 |
|----|

 Total Vehicles
- | |
|----|
| 10 |
|----|

 HGVs

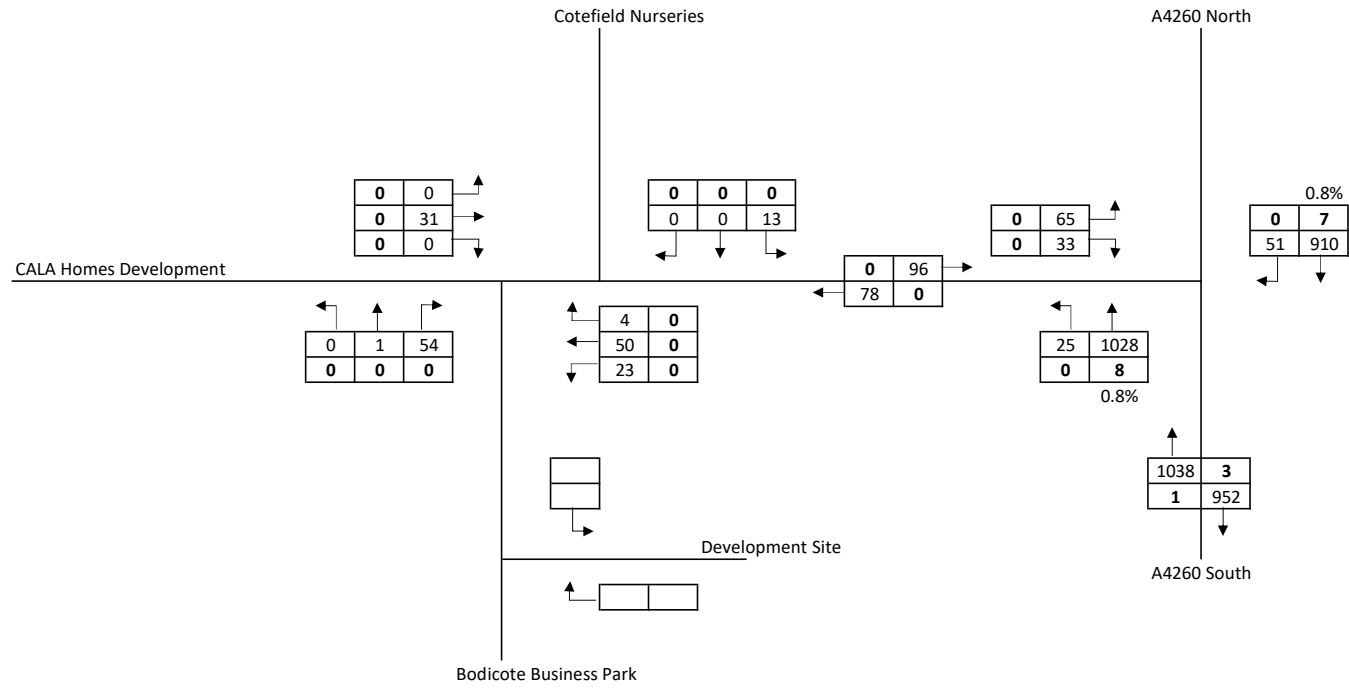

	Project	JNY9860 Cotefield Farm Retail
	Appendix	Appendix H
	Title	2024 Baseline Friday 17:00-18:00 Traffic Flows

Key

10 Total Vehicles

10 HGVs

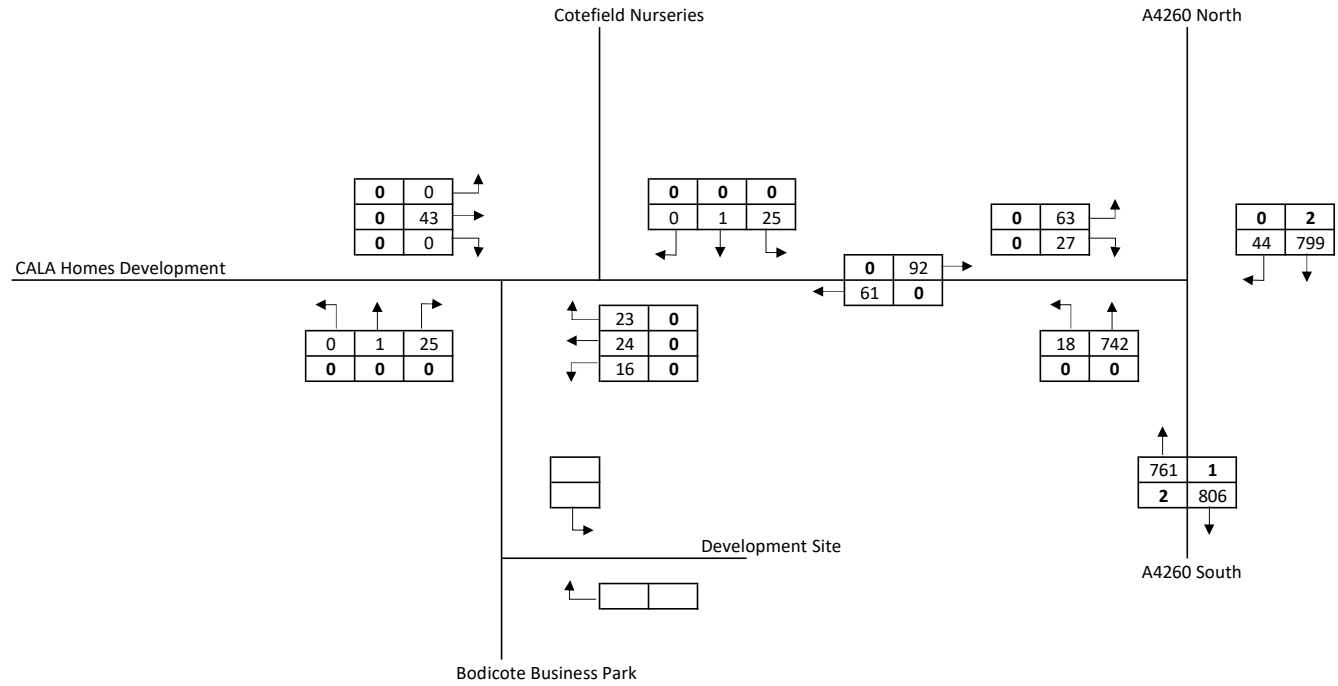

	Project	JNY9860 Cotefield Farm Retail
	Appendix	Appendix H
	Title	2024 Baseline Saturday 12:00-13:00 Traffic Flows

Key

10	Total Vehicles
10	HGVs

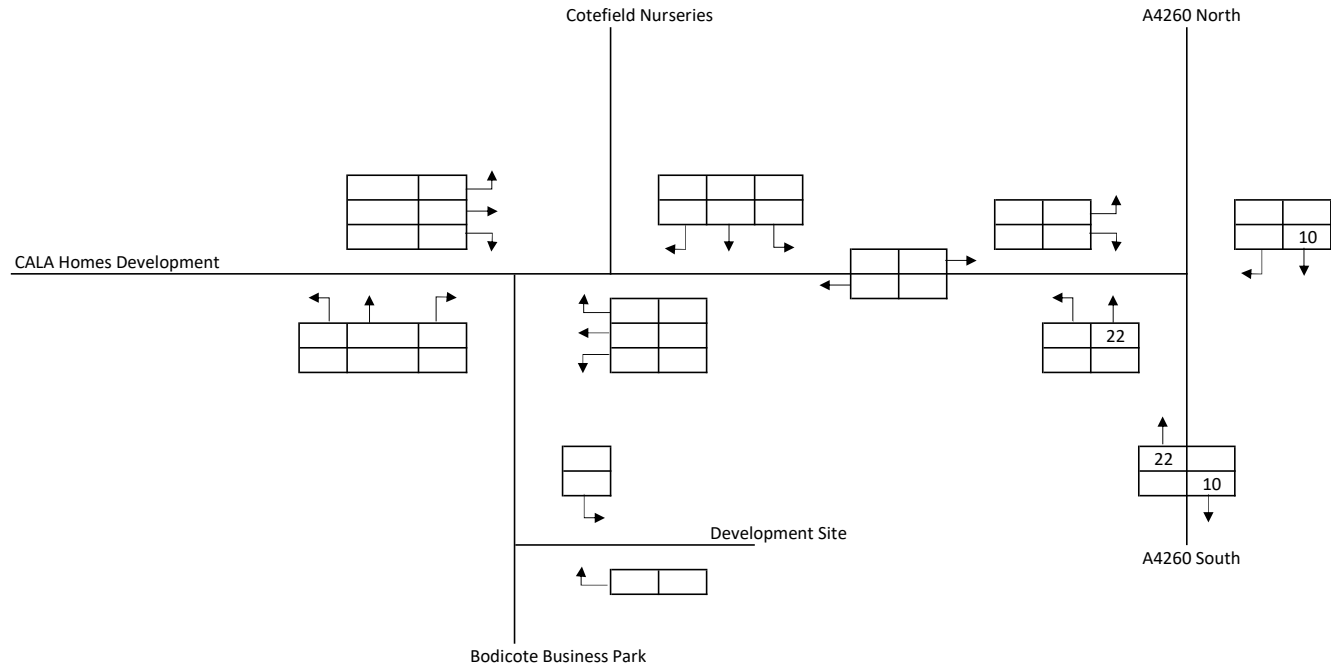

Taken from Figure 5.4 from Bankside Phase 2 Transport Assessment
 Traffic flows factored from TRICS 17:00-18:00 data to 16:00-17:00 Traffic Flows, and reduced by 10% in line with Travel Plan targets
 Based on an assessment year of 2024, approximately 18.4% of dwellings are constructed and occupied

700 dwellings to 850 dwellings = 1.21 multiplication factor

	Project	JNY9860 Cotefield Farm Retail
	Appendix	Appendix H
	Title	17/01408/OUT Bankside 2 Friday PM

Key	
10	Total Vehicles
10	HGVs

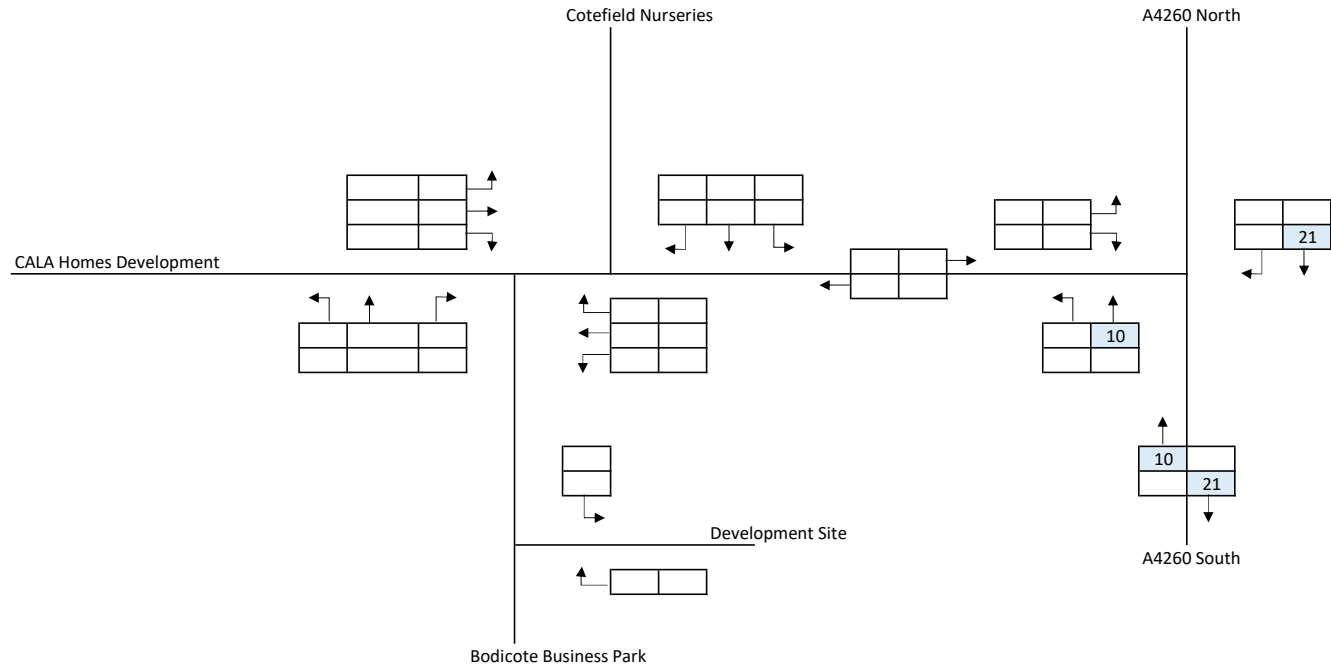

Calculated using available TRICS data
 The Saturday vehicle trips were factored using (Friday TRICS 1700-1800 trip rate / Saturday TRICS 1200-1300 trip rate)* number of Friday vehicles
 Based on an assessment year of 2024, approximately 18.4% of dwellings are constructed and occupied

700 dwellings to 850 dwellings = 1.21 multiplication factor

	Project	JNY9860 Cotefield Farm Retail
	Appendix	Appendix H
	Title	17/01408/OUT Bankside 2 Saturday Peak

Key

10	Total Vehicles
10	HGVs

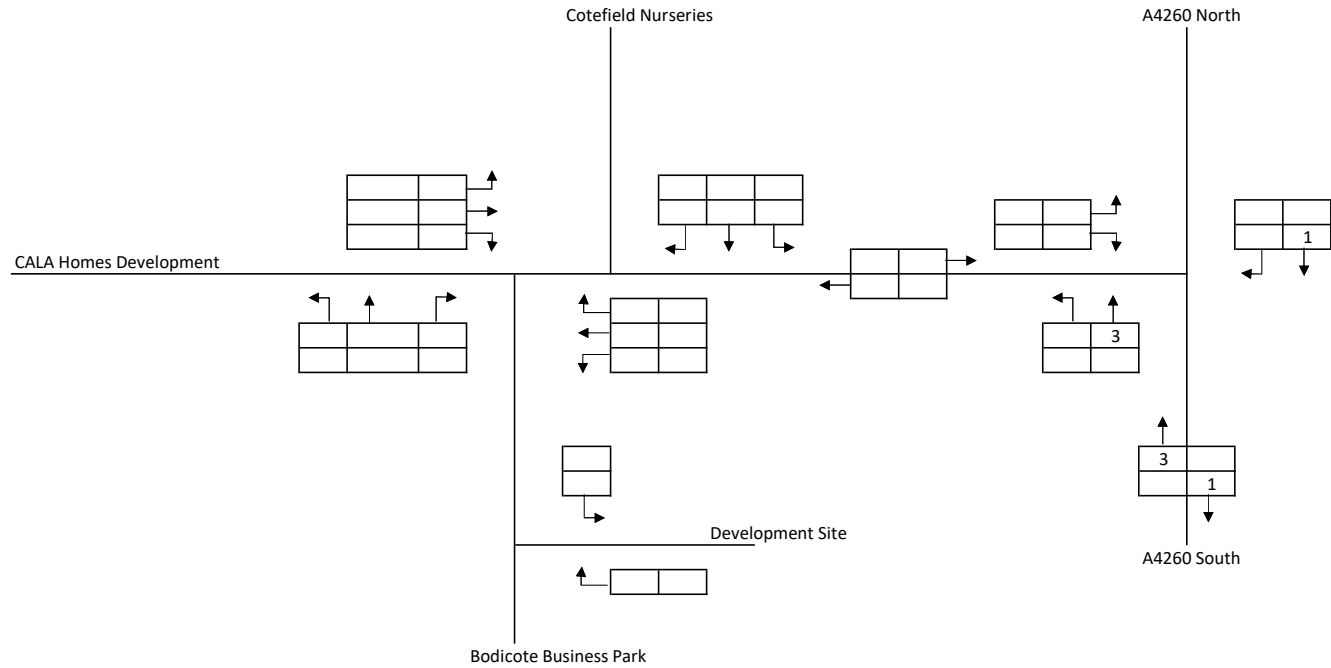

Taken from "Land at Wykham Park Farm, Banbury" TA
 Traffic flows factored from TRICS 17:00-18:00 data to 16:00-17:00 Traffic Flows, and reduced by 10% in line with Travel Plan targets
 Based on an assessment year of 2024, approximately 25.2% of dwellings are constructed and occupied

	Project	JNY9860 Cotefield Farm Retail
	Appendix	Appendix H
	Title	14/01932/OUT Wykham Park Farm Friday PM

Key	
10	Total Vehicles
10	HGVs

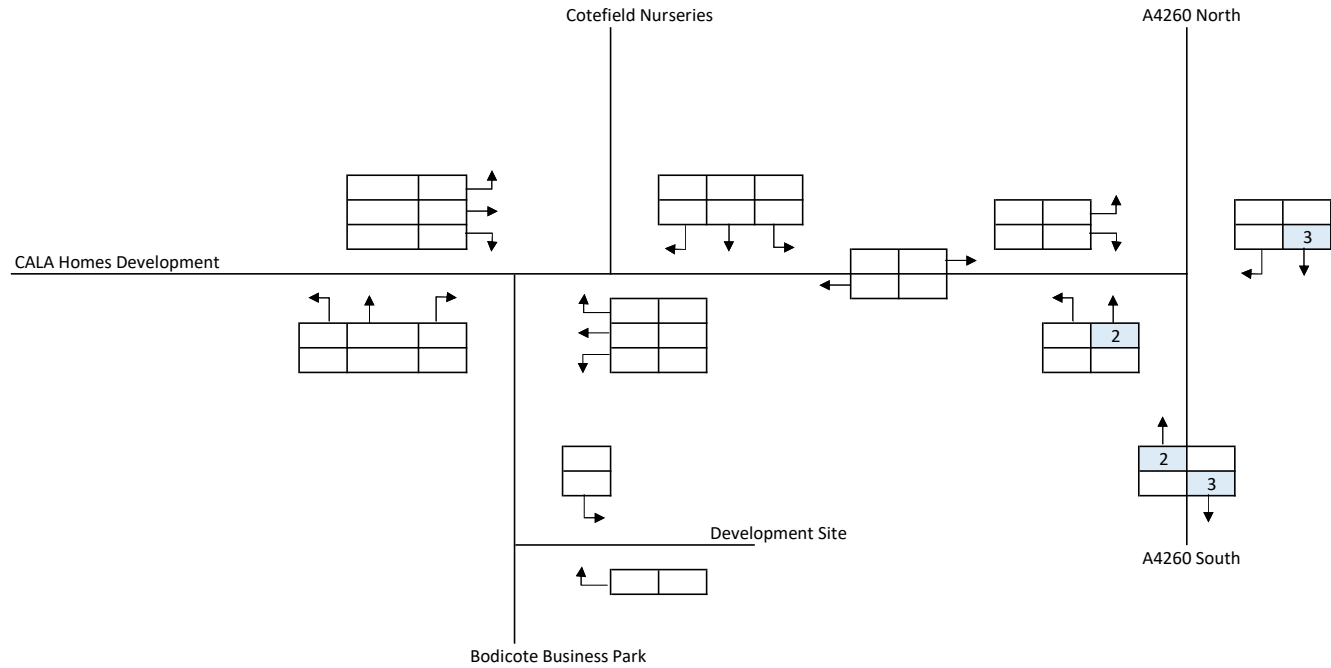

Factored using available TRICS data
 The saturday vehicle trips were factored using (Friday TRICS 1700-1800 trip rate / Saturday TRICS 1200-1300 trip rate)* number of Friday vehicles
 Based on an assessment year of 2024, approximately 25.2% of dwellings are constructed and occupied

	Project	JNY9860 Cotefield Farm Retail
	Appendix	Appendix H
	Title	14/01932/OUT Wykham Park Farm Saturday Peak

Key

- | |
|----|
| 10 |
|----|

 Total Vehicles
- | |
|----|
| 10 |
|----|

 HGVs

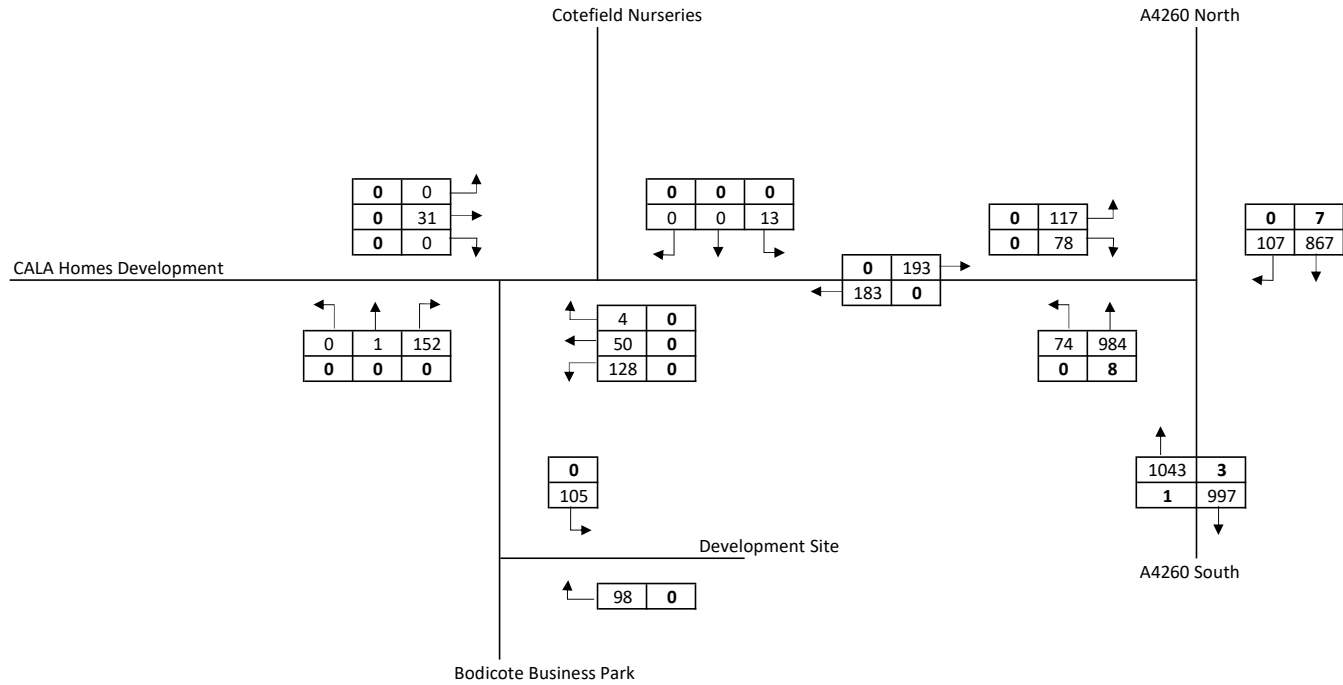

	Project	JNY9860 Cotefield Farm Retail
	Appendix	Appendix H
	Title	2024 Baseline + Development Friday PM Flows

Key

- | |
|----|
| 10 |
|----|

 Total Vehicles
- | |
|----|
| 10 |
|----|

 HGVs

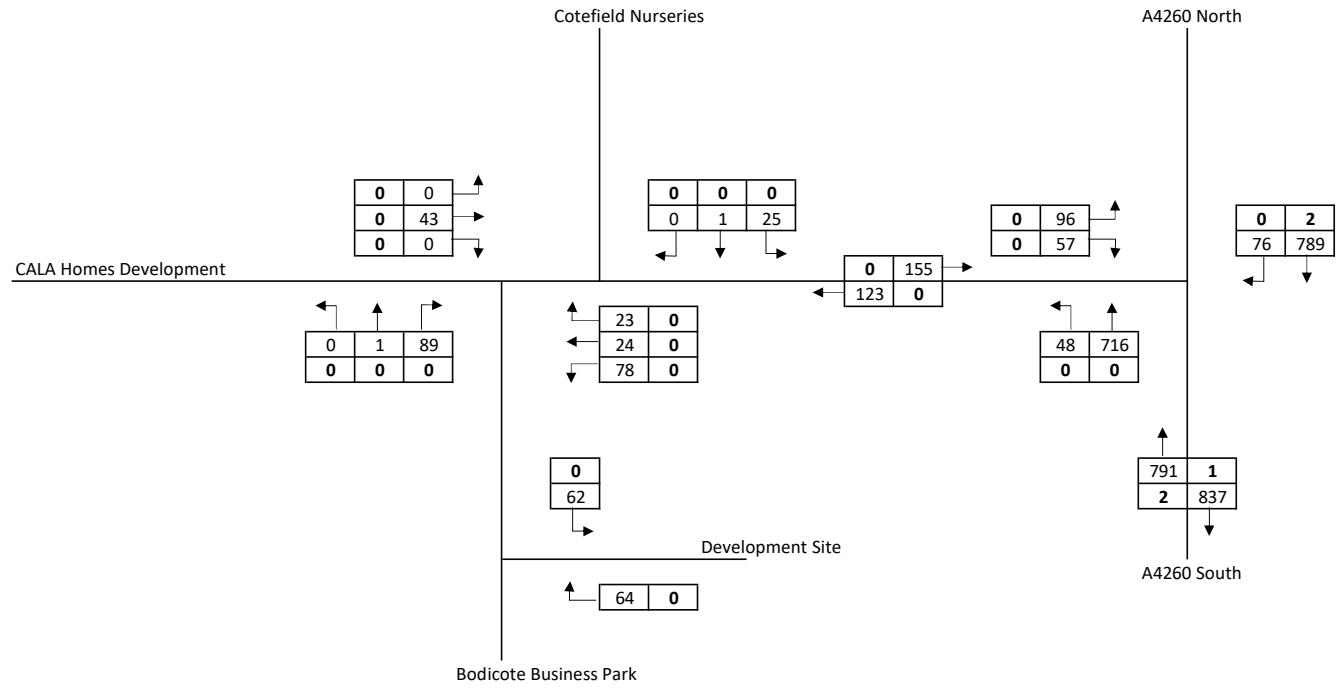

	Project	JNY9860 Cotefield Farm Retail
	Appendix	Appendix H
	Title	2024 Baseline + Development Saturday Peak Flows

Key	
10	Total Vehicles
10	HGVs

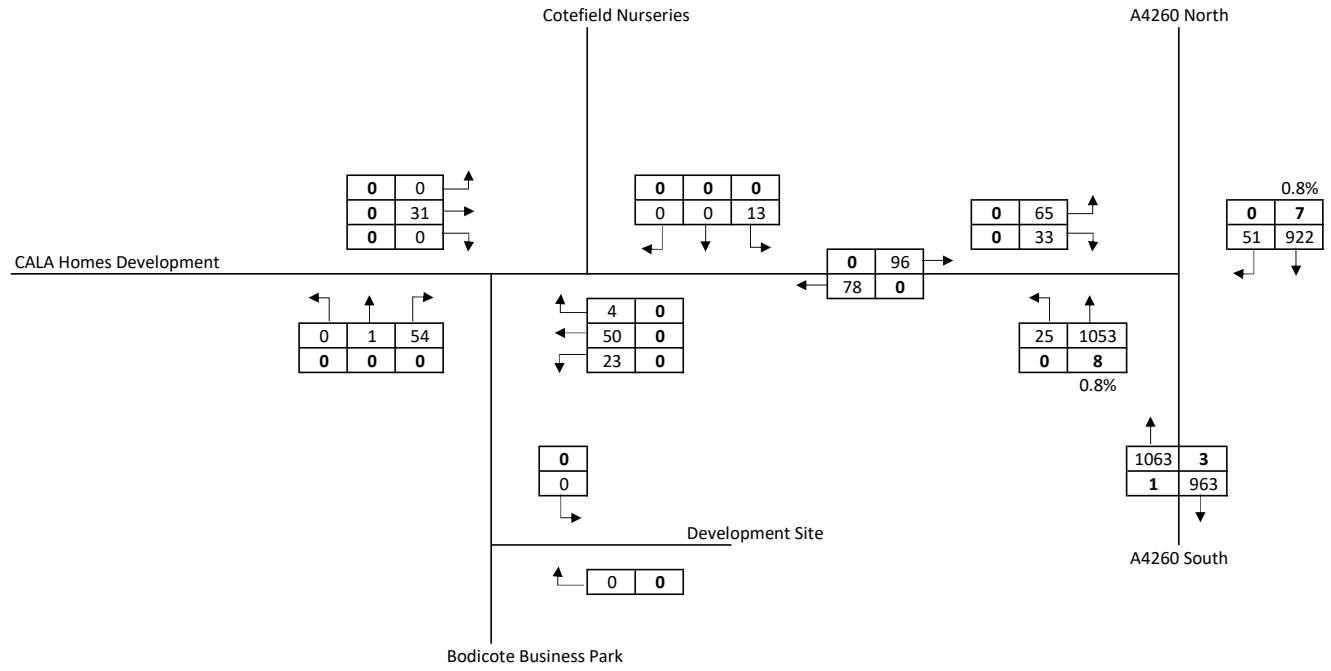

	Project	JNY9860 Cotefield Farm Retail
	Appendix	Appendix H
	Title	2024 Baseline + Cumulative Friday PM Flows

Key

10 Total Vehicles

10 HGVs

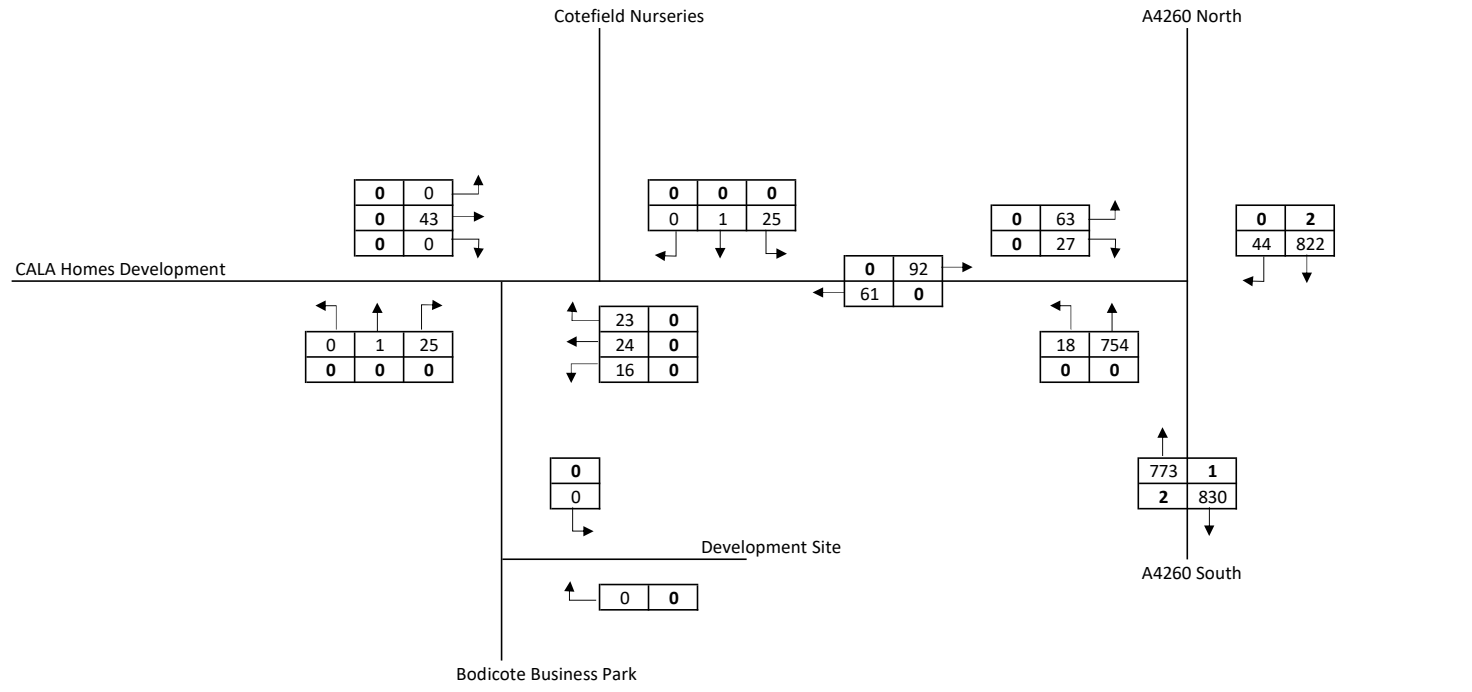

	Project	JNY9860 Cotefield Farm Retail
	Appendix	Appendix H
	Title	2024 Baseline + Cumulative Saturday Peak Flows

Key

10	Total Vehicles
10	HGVs

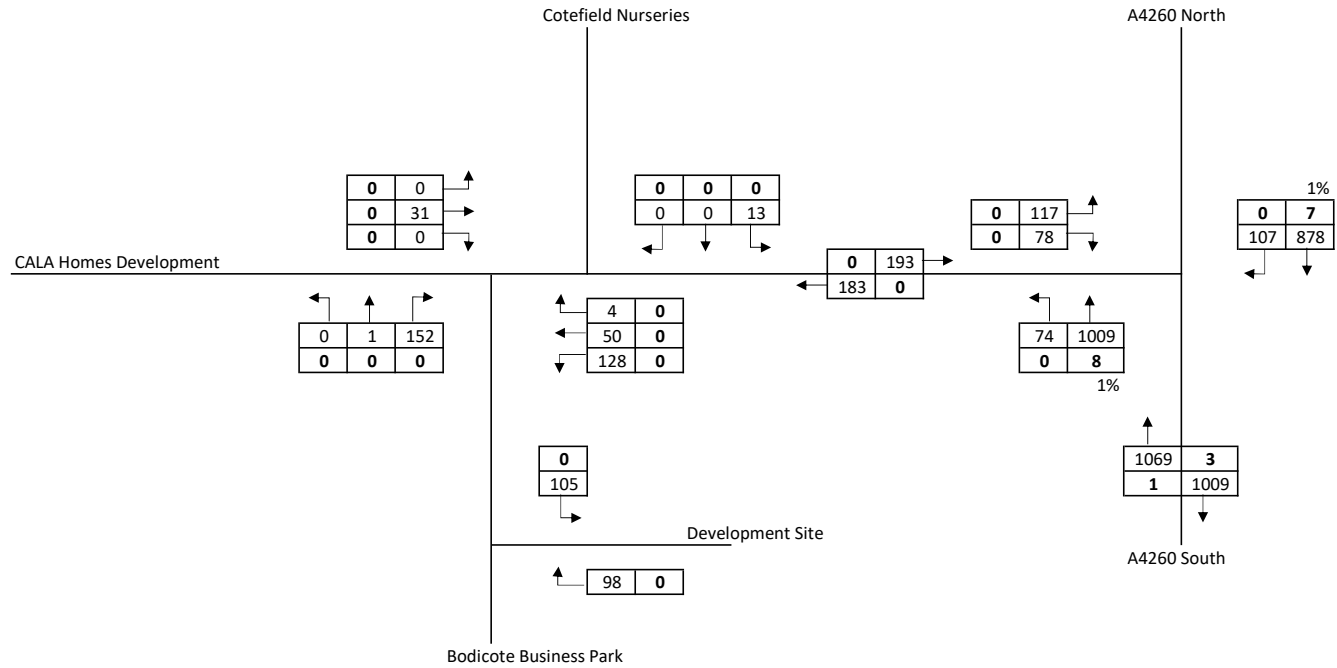

	Project	JNY9860 Cotefield Farm Retail
	Appendix	Appendix H
	Title	2024 Baseline + Cumulative + Development Friday PM Flows

Key

10 Total Vehicles

10 HGVs

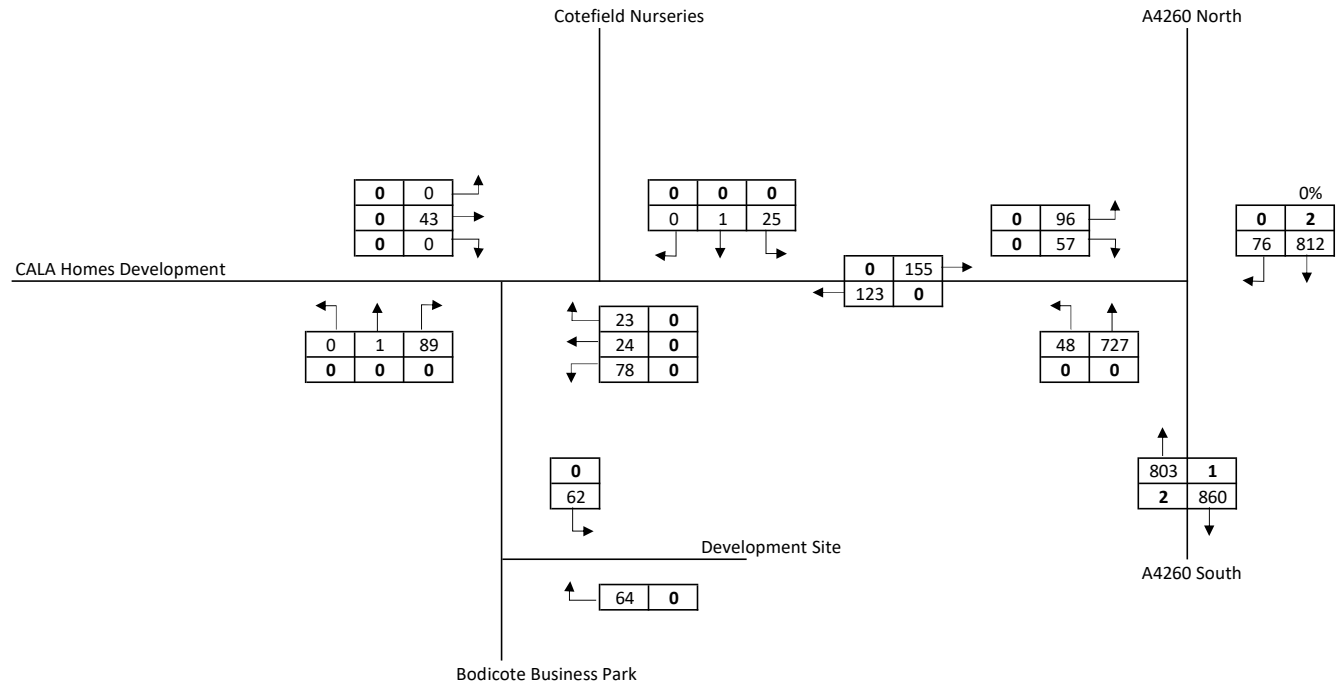

	Project	JNY9860 Cotefield Farm Retail
	Appendix	Appendix H
	Title	2024 Baseline + Cumulative + Development Saturday Peak Flows

Appendix I – Junctions 9 Output Reports

<h1>Junctions 9</h1>
<h2>PICADY 9 - Priority Intersection Module</h2>
Version: 9.0.2.5947 © Copyright TRL Limited, 2017
For sales and distribution information, program advice and maintenance, contact TRL: +44 (0)1344 770558 software@trl.co.uk www.trlsoftware.co.uk
The users of this computer program for the solution of an engineering problem are in no way relieved of their responsibility for the correctness of the solution

Filename: 2019 12 23 Friday PM Peak redone due to corrupt file.j9

Path: P:\JNY9860 - Cotefield Farm Retail\Transport\Picady

Report generation date: 23/12/2019 13:53:30

-
- »2018 Observed, PM
 - »2018 Base, PM
 - »2024 Interim Baseline, PM
 - »2024 Baseline, PM
 - »2024 Baseline + Development, PM
 - »2024 Baseline + Cumulative, PM
 - »2024 Baseline + Cumulative + Development, PM

Summary of junction performance

	PM			
	Queue (Veh)	Delay (s)	RFC	LOS
2018 Observed				
Stream B-C	0.2	9.20	0.14	A
Stream B-A	0.3	32.51	0.24	D
Stream C-AB	0.1	9.56	0.07	A
2018 Base				
Stream B-C	0.1	8.98	0.12	A
Stream B-A	0.3	29.98	0.22	D
Stream C-AB	0.0	9.17	0.04	A
2024 Interim Baseline				
Stream B-C	0.2	9.66	0.15	A
Stream B-A	0.4	37.96	0.28	E
Stream C-AB	0.1	9.91	0.09	A
2024 Baseline				
Stream B-C	0.2	10.01	0.18	B
Stream B-A	0.4	42.72	0.31	E
Stream C-AB	0.1	10.42	0.13	B
2024 Baseline + Development				
Stream B-C	0.7	19.61	0.42	C
Stream B-A	2.2	107.16	0.73	F
Stream C-AB	0.4	12.40	0.27	B
2024 Baseline + Cumulative				
Stream B-C	0.2	10.35	0.18	B
Stream B-A	0.5	48.65	0.34	E
Stream C-AB	0.1	10.65	0.13	B
2024 Baseline + Cumulative + Development				
Stream B-C	1.0	29.76	0.52	D
Stream B-A	2.9	143.71	0.80	F
Stream C-AB	0.4	12.67	0.27	B

Values shown are the highest values encountered over all time segments. Delay is the maximum value of average delay per arriving vehicle.

File summary

File Description

Title	(untitled)
Location	
Site number	
Date	23/12/2019
Version	
Status	(new file)
Identifier	
Client	
Jobnumber	
Enumerator	EUR\Joanna.gunn
Description	

Units

Distance units	Speed units	Traffic units input	Traffic units results	Flow units	Average delay units	Total delay units	Rate of delay units
m	kph	Veh	Veh	perHour	s	-Min	perMin

Analysis Options

Calculate Queue Percentiles	Calculate residual capacity	RFC Threshold	Average Delay threshold (s)	Queue threshold (PCU)
		0.85	36.00	20.00

Demand Set Summary

ID	Scenario name	Time Period name	Traffic profile type	Start time (HH:mm)	Finish time (HH:mm)	Time period length (min)	Time segment length (min)
D1	2018 Observed	PM	DIRECT	16:00	17:00	60	15
D2	2018 Base	PM	DIRECT	16:00	17:00	60	15
D3	2024 Interim Baseline	PM	DIRECT	16:00	17:00	60	15
D4	2024 Baseline	PM	DIRECT	16:00	17:00	60	15
D5	2024 Baseline + Development	PM	DIRECT	16:00	17:00	60	15
D6	2024 Baseline + Cumulative	PM	DIRECT	16:00	17:00	60	15
D7	2024 Baseline + Cumulative + Development	PM	DIRECT	16:00	17:00	60	15

Analysis Set Details

ID	Network flow scaling factor (%)
A1	100.000

2018 Observed, PM

Data Errors and Warnings

No errors or warnings

Junction Network

Junctions

Junction	Name	Junction Type	Major road direction	Junction Delay (s)	Junction LOS
1	untitled	T-Junction	Two-way	0.80	A

Junction Network Options

Driving side	Lighting
Left	Normal/unknown

Arms

Arms

Arm	Name	Description	Arm type
A	A4260 Oxford Road South		Major
B	Site Access		Minor
C	A4260 Oxford Road North		Major

Major Arm Geometry

Arm	Width of carriageway (m)	Has kerbed central reserve	Has right turn bay	Width for right turn (m)	Visibility for right turn (m)	Blocks?	Blocking queue (PCU)
C - A4260 Oxford Road North	6.00		✓	2.60	200.0	✓	6.00

Geometries for Arm C are measured opposite Arm B. Geometries for Arm A (if relevant) are measured opposite Arm D.

Minor Arm Geometry

Arm	Minor arm type	Width at give-way (m)	Width at 5m (m)	Width at 10m (m)	Width at 15m (m)	Width at 20m (m)	Estimate flare length	Flare length (PCU)	Visibility to left (m)	Visibility to right (m)
B - Site Access	One lane plus flare	10.00	10.00	8.00	5.20	4.70	✓	3.00	150	150

Slope / Intercept / Capacity

Priority Intersection Slopes and Intercepts

Junction	Stream	Intercept (Veh/hr)	Slope for A-B	Slope for A-C	Slope for C-A	Slope for C-B
1	B-A	625	0.114	0.288	0.181	0.411
1	B-C	808	0.124	0.313	-	-
1	C-B	720	0.279	0.279	-	-

The slopes and intercepts shown above do NOT include any corrections or adjustments.

Streams may be combined, in which case capacity will be adjusted.

Values are shown for the first time segment only; they may differ for subsequent time segments.

Traffic Demand

Demand Set Details

ID	Scenario name	Time Period name	Traffic profile type	Start time (HH:mm)	Finish time (HH:mm)	Time period length (min)	Time segment length (min)
D1	2018 Observed	PM	DIRECT	16:00	17:00	60	15

Vehicle mix source	PCU Factor for a HV (PCU)
HV Percentages	2.00

Demand overview (Traffic)

Arm	Linked arm	Use O-D data	Scaling Factor (%)
A - A4260 Oxford Road South			400.000
B - Site Access			400.000
C - A4260 Oxford Road North			400.000

Origin-Destination Data

Demand (Veh/hr)

		To		
		A - A4260 Oxford Road South	B - Site Access	C - A4260 Oxford Road North
From	A - A4260 Oxford Road South	0	22	998
	B - Site Access	28	0	48
	C - A4260 Oxford Road North	894	28	0

Vehicle Mix

Heavy Vehicle Percentages

		To		
		A - A4260 Oxford Road South	B - Site Access	C - A4260 Oxford Road North
From	A - A4260 Oxford Road South	0	0	1
	B - Site Access	0	0	0
	C - A4260 Oxford Road North	1	0	0

Results

Results Summary for whole modelled period

Stream	Max RFC	Max delay (s)	Max Queue (Veh)	Max LOS
B-C	0.14	9.20	0.2	A
B-A	0.24	32.51	0.3	D
C-AB	0.07	9.56	0.1	A
C-A				
A-B				
A-C				

Main Results for each time segment

16:00 - 16:15

Stream	Total Demand (Veh/hr)	Capacity (Veh/hr)	RFC	Throughput (Veh/hr)	End queue (Veh)	Delay (s)	LOS
B-C	40	516	0.078	40	0.1	7.562	A
B-A	24	205	0.115	23	0.1	19.686	C
C-AB	26	470	0.056	26	0.1	8.111	A
C-A	842			842			
A-B	19			19			
A-C	869			869			

16:15 - 16:30

Stream	Total Demand (Veh/hr)	Capacity (Veh/hr)	RFC	Throughput (Veh/hr)	End queue (Veh)	Delay (s)	LOS
B-C	45	450	0.101	45	0.1	8.896	A
B-A	27	137	0.194	26	0.2	32.408	D
C-AB	29	418	0.069	29	0.1	9.252	A
C-A	923			923			
A-B	23			23			
A-C	1049			1049			

16:30 - 16:45

Stream	Total Demand (Veh/hr)	Capacity (Veh/hr)	RFC	Throughput (Veh/hr)	End queue (Veh)	Delay (s)	LOS
B-C	63	466	0.136	63	0.2	8.936	A
B-A	37	151	0.244	37	0.3	31.348	D
C-AB	30	439	0.069	30	0.1	8.797	A
C-A	962			962			
A-B	21			21			
A-C	975			975			

16:45 - 17:00

Stream	Total Demand (Veh/hr)	Capacity (Veh/hr)	RFC	Throughput (Veh/hr)	End queue (Veh)	Delay (s)	LOS
B-C	43	435	0.099	43	0.1	9.200	A
B-A	25	136	0.184	25	0.2	32.507	D
C-AB	27	403	0.066	27	0.1	9.559	A
C-A	849			849			
A-B	24			24			
A-C	1100			1100			

2018 Base, PM

Data Errors and Warnings

No errors or warnings

Junction Network

Junctions

Junction	Name	Junction Type	Major road direction	Junction Delay (s)	Junction LOS
1	untitled	T-Junction	Two-way	0.64	A

Junction Network Options

Driving side	Lighting
Left	Normal/unknown

Traffic Demand

Demand Set Details

ID	Scenario name	Time Period name	Traffic profile type	Start time (HH:mm)	Finish time (HH:mm)	Time period length (min)	Time segment length (min)
D2	2018 Base	PM	DIRECT	16:00	17:00	60	15

Vehicle mix source	PCU Factor for a HV (PCU)
HV Percentages	2.00

Demand overview (Traffic)

Arm	Linked arm	Use O-D data	Scaling Factor (%)
A - A4260 Oxford Road South			400.000
B - Site Access			400.000
C - A4260 Oxford Road North			400.000

Origin-Destination Data

Demand (Veh/hr)

		To		
		A - A4260 Oxford Road South	B - Site Access	C - A4260 Oxford Road North
From	A - A4260 Oxford Road South	0	11	998
	B - Site Access	25	0	42
	C - A4260 Oxford Road North	894	15	0

Vehicle Mix

Heavy Vehicle Percentages

		To		
		A - A4260 Oxford Road South	B - Site Access	C - A4260 Oxford Road North
From	A - A4260 Oxford Road South	0	0	1
	B - Site Access	0	0	0
	C - A4260 Oxford Road North	1	0	0

Results

Results Summary for whole modelled period

Stream	Max RFC	Max delay (s)	Max Queue (Veh)	Max LOS
B-C	0.12	8.98	0.1	A
B-A	0.22	29.98	0.3	D
C-AB	0.04	9.17	0.0	A
C-A				
A-B				
A-C				

Main Results for each time segment

16:00 - 16:15

Stream	Total Demand (Veh/hr)	Capacity (Veh/hr)	RFC	Throughput (Veh/hr)	End queue (Veh)	Delay (s)	LOS
B-C	35	520	0.068	35	0.1	7.422	A
B-A	21	212	0.098	20	0.1	18.715	C
C-AB	14	473	0.030	14	0.0	7.840	A
C-A	842			842			
A-B	10			10			
A-C	866			866			

16:15 - 16:30

Stream	Total Demand (Veh/hr)	Capacity (Veh/hr)	RFC	Throughput (Veh/hr)	End queue (Veh)	Delay (s)	LOS
B-C	40	454	0.088	40	0.1	8.684	A
B-A	24	144	0.166	24	0.2	29.886	D
C-AB	16	421	0.037	15	0.0	8.872	A
C-A	924			924			
A-B	12			12			
A-C	1048			1048			

16:30 - 16:45

Stream	Total Demand (Veh/hr)	Capacity (Veh/hr)	RFC	Throughput (Veh/hr)	End queue (Veh)	Delay (s)	LOS
B-C	58	470	0.123	58	0.1	8.713	A
B-A	34	158	0.217	34	0.3	28.920	D
C-AB	16	443	0.037	16	0.0	8.440	A
C-A	964			964			
A-B	11			11			
A-C	973			973			

16:45 - 17:00

Stream	Total Demand (Veh/hr)	Capacity (Veh/hr)	RFC	Throughput (Veh/hr)	End queue (Veh)	Delay (s)	LOS
B-C	38	439	0.086	38	0.1	8.983	A
B-A	22	143	0.157	23	0.2	29.982	D
C-AB	14	407	0.035	14	0.0	9.175	A
C-A	850			850			
A-B	12			12			
A-C	1100			1100			

2024 Interim Baseline, PM

Data Errors and Warnings

No errors or warnings

Junction Network

Junctions

Junction	Name	Junction Type	Major road direction	Junction Delay (s)	Junction LOS
1	untitled	T-Junction	Two-way	0.95	A

Junction Network Options

Driving side	Lighting
Left	Normal/unknown

Traffic Demand

Demand Set Details

ID	Scenario name	Time Period name	Traffic profile type	Start time (HH:mm)	Finish time (HH:mm)	Time period length (min)	Time segment length (min)
D3	2024 Interim Baseline	PM	DIRECT	16:00	17:00	60	15

Vehicle mix source	PCU Factor for a HV (PCU)
HV Percentages	2.00

Demand overview (Traffic)

Arm	Linked arm	Use O-D data	Scaling Factor (%)
A - A4260 Oxford Road South			400.000
B - Site Access			400.000
C - A4260 Oxford Road North			400.000

Origin-Destination Data

Demand (Veh/hr)

		To		
		A - A4260 Oxford Road South	B - Site Access	C - A4260 Oxford Road North
From	A - A4260 Oxford Road South	0	19	1028
	B - Site Access	29	0	53
	C - A4260 Oxford Road North	910	34	0

Vehicle Mix

Heavy Vehicle Percentages

		To		
		A - A4260 Oxford Road South	B - Site Access	C - A4260 Oxford Road North
From	A - A4260 Oxford Road South	0	0	1
	B - Site Access	0	0	0
	C - A4260 Oxford Road North	1	0	0

Results

Results Summary for whole modelled period

Stream	Max RFC	Max delay (s)	Max Queue (Veh)	Max LOS
B-C	0.15	9.66	0.2	A
B-A	0.28	37.96	0.4	E
C-AB	0.09	9.91	0.1	A
C-A				
A-B				
A-C				

Main Results for each time segment

16:00 - 16:15

Stream	Total Demand (Veh/hr)	Capacity (Veh/hr)	RFC	Throughput (Veh/hr)	End queue (Veh)	Delay (s)	LOS
B-C	47	519	0.090	46	0.1	7.609	A
B-A	25	203	0.126	25	0.1	20.170	C
C-AB	32	473	0.068	32	0.1	8.151	A
C-A	856			856			
A-B	16			16			
A-C	860			860			

16:15 - 16:30

Stream	Total Demand (Veh/hr)	Capacity (Veh/hr)	RFC	Throughput (Veh/hr)	End queue (Veh)	Delay (s)	LOS
B-C	52	438	0.118	52	0.1	9.322	A
B-A	28	123	0.231	28	0.3	37.686	E
C-AB	35	410	0.085	35	0.1	9.595	A
C-A	937			937			
A-B	20			20			
A-C	1080			1080			

16:30 - 16:45

Stream	Total Demand (Veh/hr)	Capacity (Veh/hr)	RFC	Throughput (Veh/hr)	End queue (Veh)	Delay (s)	LOS
B-C	70	453	0.154	70	0.2	9.381	A
B-A	38	137	0.279	38	0.4	36.232	E
C-AB	36	431	0.084	36	0.1	9.115	A
C-A	976			976			
A-B	19			19			
A-C	1005			1005			

16:45 - 17:00

Stream	Total Demand (Veh/hr)	Capacity (Veh/hr)	RFC	Throughput (Veh/hr)	End queue (Veh)	Delay (s)	LOS
B-C	49	422	0.116	49	0.1	9.657	A
B-A	27	122	0.220	27	0.3	37.960	E
C-AB	32	395	0.082	32	0.1	9.914	A
C-A	864			864			
A-B	21			21			
A-C	1131			1131			

2024 Baseline, PM

Data Errors and Warnings

No errors or warnings

Junction Network

Junctions

Junction	Name	Junction Type	Major road direction	Junction Delay (s)	Junction LOS
1	untitled	T-Junction	Two-way	1.20	A

Junction Network Options

Driving side	Lighting
Left	Normal/unknown

Traffic Demand

Demand Set Details

ID	Scenario name	Time Period name	Traffic profile type	Start time (HH:mm)	Finish time (HH:mm)	Time period length (min)	Time segment length (min)
D4	2024 Baseline	PM	DIRECT	16:00	17:00	60	15

Vehicle mix source	PCU Factor for a HV (PCU)
HV Percentages	2.00

Demand overview (Traffic)

Arm	Linked arm	Use O-D data	Scaling Factor (%)
A - A4260 Oxford Road South			400.000
B - Site Access			400.000
C - A4260 Oxford Road North			400.000

Origin-Destination Data

Demand (Veh/hr)

		To		
		A - A4260 Oxford Road South	B - Site Access	C - A4260 Oxford Road North
From	A - A4260 Oxford Road South	0	25	1028
	B - Site Access	33	0	65
	C - A4260 Oxford Road North	910	51	0

Vehicle Mix

Heavy Vehicle Percentages

		To		
		A - A4260 Oxford Road South	B - Site Access	C - A4260 Oxford Road North
From	A - A4260 Oxford Road South	0	0	1
	B - Site Access	0	0	0
	C - A4260 Oxford Road North	1	0	0

Results

Results Summary for whole modelled period

Stream	Max RFC	Max delay (s)	Max Queue (Veh)	Max LOS
B-C	0.18	10.01	0.2	B
B-A	0.31	42.72	0.4	E
C-AB	0.13	10.42	0.1	B
C-A				
A-B				
A-C				

Main Results for each time segment

16:00 - 16:15

Stream	Total Demand (Veh/hr)	Capacity (Veh/hr)	RFC	Throughput (Veh/hr)	End queue (Veh)	Delay (s)	LOS
B-C	56	504	0.111	55	0.1	8.010	A
B-A	28	183	0.154	28	0.2	23.028	C
C-AB	48	461	0.105	48	0.1	8.707	A
C-A	860			860			
A-B	22			22			
A-C	898			898			

16:15 - 16:30

Stream	Total Demand (Veh/hr)	Capacity (Veh/hr)	RFC	Throughput (Veh/hr)	End queue (Veh)	Delay (s)	LOS
B-C	61	434	0.141	61	0.2	9.649	A
B-A	31	115	0.271	30	0.3	42.401	E
C-AB	53	409	0.129	53	0.1	10.098	B
C-A	939			939			
A-B	26			26			
A-C	1078			1078			

16:30 - 16:45

Stream	Total Demand (Veh/hr)	Capacity (Veh/hr)	RFC	Throughput (Veh/hr)	End queue (Veh)	Delay (s)	LOS
B-C	80	449	0.177	79	0.2	9.730	A
B-A	40	128	0.315	40	0.4	40.560	E
C-AB	55	430	0.127	55	0.1	9.587	A
C-A	977			977			
A-B	24			24			
A-C	1004			1004			

16:45 - 17:00

Stream	Total Demand (Veh/hr)	Capacity (Veh/hr)	RFC	Throughput (Veh/hr)	End queue (Veh)	Delay (s)	LOS
B-C	58	418	0.139	59	0.2	10.007	B
B-A	30	115	0.259	30	0.4	42.716	E
C-AB	49	394	0.123	49	0.1	10.417	B
C-A	867			867			
A-B	27			27			
A-C	1129			1129			

2024 Baseline + Development, PM

Data Errors and Warnings

No errors or warnings

Junction Network

Junctions

Junction	Name	Junction Type	Major road direction	Junction Delay (s)	Junction LOS
1	untitled	T-Junction	Two-way	5.35	A

Junction Network Options

Driving side	Lighting
Left	Normal/unknown

Traffic Demand

Demand Set Details

ID	Scenario name	Time Period name	Traffic profile type	Start time (HH:mm)	Finish time (HH:mm)	Time period length (min)	Time segment length (min)
D5	2024 Baseline + Development	PM	DIRECT	16:00	17:00	60	15

Vehicle mix source	PCU Factor for a HV (PCU)
HV Percentages	2.00

Demand overview (Traffic)

Arm	Linked arm	Use O-D data	Scaling Factor (%)
A - A4260 Oxford Road South			400.000
B - Site Access			400.000
C - A4260 Oxford Road North			400.000

Origin-Destination Data

Demand (Veh/hr)

		To		
		A - A4260 Oxford Road South	B - Site Access	C - A4260 Oxford Road North
From	A - A4260 Oxford Road South	0	74	985
	B - Site Access	78	0	117
	C - A4260 Oxford Road North	867	107	0

Vehicle Mix

Heavy Vehicle Percentages

		To		
		A - A4260 Oxford Road South	B - Site Access	C - A4260 Oxford Road North
From	A - A4260 Oxford Road South	0	0	1
	B - Site Access	0	0	0
	C - A4260 Oxford Road North	1	0	0

Results

Results Summary for whole modelled period

Stream	Max RFC	Max delay (s)	Max Queue (Veh)	Max LOS
B-C	0.42	19.61	0.7	C
B-A	0.73	107.16	2.2	F
C-AB	0.27	12.40	0.4	B
C-A				
A-B				
A-C				

Main Results for each time segment

16:00 - 16:15

Stream	Total Demand (Veh/hr)	Capacity (Veh/hr)	RFC	Throughput (Veh/hr)	End queue (Veh)	Delay (s)	LOS
B-C	110	465	0.238	109	0.3	10.091	B
B-A	74	177	0.416	71	0.7	33.197	D
C-AB	101	459	0.220	100	0.3	10.005	B
C-A	819			819			
A-B	65			65			
A-C	863			863			

16:15 - 16:30

Stream	Total Demand (Veh/hr)	Capacity (Veh/hr)	RFC	Throughput (Veh/hr)	End queue (Veh)	Delay (s)	LOS
B-C	115	326	0.353	114	0.5	16.928	C
B-A	77	107	0.717	72	1.9	92.387	F
C-AB	110	407	0.271	110	0.4	12.101	B
C-A	894			894			
A-B	78			78			
A-C	1034			1034			

16:30 - 16:45

Stream	Total Demand (Veh/hr)	Capacity (Veh/hr)	RFC	Throughput (Veh/hr)	End queue (Veh)	Delay (s)	LOS
B-C	132	314	0.420	131	0.7	19.608	C
B-A	88	120	0.733	87	2.2	100.549	F
C-AB	115	429	0.268	115	0.4	11.473	B
C-A	929			929			
A-B	72			72			
A-C	964			964			

16:45 - 17:00

Stream	Total Demand (Veh/hr)	Capacity (Veh/hr)	RFC	Throughput (Veh/hr)	End queue (Veh)	Delay (s)	LOS
B-C	113	299	0.377	113	0.6	19.412	C
B-A	75	109	0.691	75	2.2	107.158	F
C-AB	102	392	0.260	102	0.4	12.400	B
C-A	826			826			
A-B	81			81			
A-C	1083			1083			

2024 Baseline + Cumulative, PM

Data Errors and Warnings

No errors or warnings

Junction Network

Junctions

Junction	Name	Junction Type	Major road direction	Junction Delay (s)	Junction LOS
1	untitled	T-Junction	Two-way	1.28	A

Junction Network Options

Driving side	Lighting
Left	Normal/unknown

Traffic Demand

Demand Set Details

ID	Scenario name	Time Period name	Traffic profile type	Start time (HH:mm)	Finish time (HH:mm)	Time period length (min)	Time segment length (min)
D6	2024 Baseline + Cumulative	PM	DIRECT	16:00	17:00	60	15

Vehicle mix source	PCU Factor for a HV (PCU)
HV Percentages	2.00

Demand overview (Traffic)

Arm	Linked arm	Use O-D data	Scaling Factor (%)
A - A4260 Oxford Road South			400.000
B - Site Access			400.000
C - A4260 Oxford Road North			400.000

Origin-Destination Data

Demand (Veh/hr)

From	To		
	A - A4260 Oxford Road South	B - Site Access	C - A4260 Oxford Road North
A - A4260 Oxford Road South	0	25	1065
B - Site Access	33	0	65
C - A4260 Oxford Road North	927	51	0

Vehicle Mix

Heavy Vehicle Percentages

From	To		
	A - A4260 Oxford Road South	B - Site Access	C - A4260 Oxford Road North
A - A4260 Oxford Road South	0	0	1
B - Site Access	0	0	0
C - A4260 Oxford Road North	1	0	0

Results

Results Summary for whole modelled period

Stream	Max RFC	Max delay (s)	Max Queue (Veh)	Max LOS
B-C	0.18	10.35	0.2	B
B-A	0.34	48.65	0.5	E
C-AB	0.13	10.65	0.1	B
C-A				
A-B				
A-C				

Main Results for each time segment

16:00 - 16:15

Stream	Total Demand (Veh/hr)	Capacity (Veh/hr)	RFC	Throughput (Veh/hr)	End queue (Veh)	Delay (s)	LOS
B-C	56	494	0.113	55	0.1	8.188	A
B-A	28	173	0.164	28	0.2	24.627	C
C-AB	48	453	0.106	48	0.1	8.872	A
C-A	872			872			
A-B	22			22			
A-C	926			926			

16:15 - 16:30

Stream	Total Demand (Veh/hr)	Capacity (Veh/hr)	RFC	Throughput (Veh/hr)	End queue (Veh)	Delay (s)	LOS
B-C	61	422	0.145	61	0.2	9.964	A
B-A	31	104	0.297	30	0.4	48.058	E
C-AB	52	401	0.131	52	0.1	10.318	B
C-A	952			952			
A-B	26			26			
A-C	1106			1106			

16:30 - 16:45

Stream	Total Demand (Veh/hr)	Capacity (Veh/hr)	RFC	Throughput (Veh/hr)	End queue (Veh)	Delay (s)	LOS
B-C	80	437	0.182	79	0.2	10.064	B
B-A	40	118	0.342	40	0.5	45.783	E
C-AB	54	422	0.129	54	0.1	9.784	A
C-A	990			990			
A-B	24			24			
A-C	1032			1032			

16:45 - 17:00

Stream	Total Demand (Veh/hr)	Capacity (Veh/hr)	RFC	Throughput (Veh/hr)	End queue (Veh)	Delay (s)	LOS
B-C	58	407	0.144	59	0.2	10.351	B
B-A	30	104	0.284	30	0.4	48.652	E
C-AB	48	386	0.125	48	0.1	10.651	B
C-A	880			880			
A-B	27			27			
A-C	1157			1157			

2024 Baseline + Cumulative + Development, PM

Data Errors and Warnings

No errors or warnings

Junction Network

Junctions

Junction	Name	Junction Type	Major road direction	Junction Delay (s)	Junction LOS
1	untitled	T-Junction	Two-way	7.05	A

Junction Network Options

Driving side	Lighting
Left	Normal/unknown

Traffic Demand

Demand Set Details

ID	Scenario name	Time Period name	Traffic profile type	Start time (HH:mm)	Finish time (HH:mm)	Time period length (min)	Time segment length (min)
D7	2024 Baseline + Cumulative + Development	PM	DIRECT	16:00	17:00	60	15

Vehicle mix source	PCU Factor for a HV (PCU)
HV Percentages	2.00

Demand overview (Traffic)

Arm	Linked arm	Use O-D data	Scaling Factor (%)
A - A4260 Oxford Road South			400.000
B - Site Access			400.000
C - A4260 Oxford Road North			400.000

Origin-Destination Data

Demand (Veh/hr)

		To		
		A - A4260 Oxford Road South	B - Site Access	C - A4260 Oxford Road North
From	A - A4260 Oxford Road South	0	74	1022
	B - Site Access	78	0	117
	C - A4260 Oxford Road North	884	107	0

Vehicle Mix

Heavy Vehicle Percentages

		To		
		A - A4260 Oxford Road South	B - Site Access	C - A4260 Oxford Road North
From	A - A4260 Oxford Road South	0	0	1
	B - Site Access	0	0	0
	C - A4260 Oxford Road North	1	0	0

Results

Results Summary for whole modelled period

Stream	Max RFC	Max delay (s)	Max Queue (Veh)	Max LOS
B-C	0.52	29.76	1.0	D
B-A	0.80	143.71	2.9	F
C-AB	0.27	12.67	0.4	B
C-A				
A-B				
A-C				

Main Results for each time segment

16:00 - 16:15

Stream	Total Demand (Veh/hr)	Capacity (Veh/hr)	RFC	Throughput (Veh/hr)	End queue (Veh)	Delay (s)	LOS
B-C	110	454	0.243	109	0.3	10.403	B
B-A	74	168	0.439	71	0.7	36.146	E
C-AB	101	452	0.223	100	0.3	10.183	B
C-A	831			831			
A-B	64			64			
A-C	888			888			

16:15 - 16:30

Stream	Total Demand (Veh/hr)	Capacity (Veh/hr)	RFC	Throughput (Veh/hr)	End queue (Veh)	Delay (s)	LOS
B-C	115	281	0.410	114	0.7	21.361	C
B-A	77	98	0.786	70	2.3	113.407	F
C-AB	110	400	0.274	109	0.4	12.357	B
C-A	906			906			
A-B	77			77			
A-C	1059			1059			

16:30 - 16:45

Stream	Total Demand (Veh/hr)	Capacity (Veh/hr)	RFC	Throughput (Veh/hr)	End queue (Veh)	Delay (s)	LOS
B-C	132	253	0.522	131	1.0	29.035	D
B-A	88	111	0.796	86	2.8	129.231	F
C-AB	114	422	0.271	114	0.4	11.702	B
C-A	942			942			
A-B	72			72			
A-C	988			988			

16:45 - 17:00

Stream	Total Demand (Veh/hr)	Capacity (Veh/hr)	RFC	Throughput (Veh/hr)	End queue (Veh)	Delay (s)	LOS
B-C	113	234	0.481	113	1.0	29.758	D
B-A	75	99	0.757	75	2.9	143.714	F
C-AB	102	386	0.263	102	0.4	12.675	B
C-A	838			838			
A-B	80			80			
A-C	1108			1108			

<h1>Junctions 9</h1>
<h2>PICADY 9 - Priority Intersection Module</h2>
Version: 9.0.2.5947 © Copyright TRL Limited, 2017
For sales and distribution information, program advice and maintenance, contact TRL: +44 (0)1344 770558 software@trl.co.uk www.trlsoftware.co.uk
The users of this computer program for the solution of an engineering problem are in no way relieved of their responsibility for the correctness of the solution

Filename: 2019 12 23 Saturday Peak redone due to corrupt file.j9

Path: P:\JNY9860 - Cotefield Farm Retail\Transport\Picady

Report generation date: 23/12/2019 13:52:05

«2024 Baseline + Cumulative + Development,

- »Junction Network
- »Arms
- »Traffic Demand
- »Origin-Destination Data
- »Vehicle Mix
- »Results

Summary of junction performance

	Queue (Veh)	Delay (s)	RFC	LOS
2018 Observed				
Stream B-C	0.1	7.28	0.09	A
Stream B-A	0.1	18.97	0.10	C
Stream C-AB	0.1	8.13	0.09	A
2018 Base				
Stream B-C	0.1	7.02	0.07	A
Stream B-A	0.1	17.79	0.07	C
Stream C-AB	0.1	7.83	0.06	A
2024 Interim Baseline				
Stream B-C	0.1	7.38	0.10	A
Stream B-A	0.1	19.56	0.11	C
Stream C-AB	0.1	8.06	0.08	A
2024 Baseline				
Stream B-C	0.1	7.77	0.13	A
Stream B-A	0.2	20.93	0.15	C
Stream C-AB	0.1	8.26	0.10	A
2024 Baseline + Development				
Stream B-C	0.3	9.01	0.21	A
Stream B-A	0.5	26.89	0.32	D
Stream C-AB	0.2	9.01	0.17	A
2024 Baseline + Cumulative				
Stream B-C	0.2	7.85	0.13	A
Stream B-A	0.2	22.00	0.15	C
Stream C-AB	0.1	8.33	0.10	A
2024 Baseline + Cumulative + Development				
Stream B-C	0.3	9.15	0.21	A
Stream B-A	0.5	28.63	0.33	D
Stream C-AB	0.2	9.09	0.17	A

Values shown are the highest values encountered over all time segments. Delay is the maximum value of average delay per arriving vehicle.

File summary

File Description

Title	(untitled)
Location	
Site number	
Date	23/12/2019
Version	
Status	(new file)
Identifier	
Client	
Jobnumber	
Enumerator	EUR\Joanna.gunn
Description	

Units

Distance units	Speed units	Traffic units input	Traffic units results	Flow units	Average delay units	Total delay units	Rate of delay units
m	kph	Veh	Veh	perHour	s	-Min	perMin

Analysis Options

Calculate Queue Percentiles	Calculate residual capacity	RFC Threshold	Average Delay threshold (s)	Queue threshold (PCU)
		0.85	36.00	20.00

Analysis Set Details

ID	Network flow scaling factor (%)
A1	100.000

Demand Set Details

ID	Scenario name	Traffic profile type	Start time (HH:mm)	Finish time (HH:mm)	Time segment length (min)
D7	2024 Baseline + Cumulative + Development	ONE HOUR	11:45	13:15	15

2024 Baseline + Cumulative + Development,

Data Errors and Warnings

No errors or warnings

Junction Network

Junctions

Junction	Name	Junction Type	Major road direction	Junction Delay (s)	Junction LOS
1	untitled	T-Junction	Two-way	1.75	A

Junction Network Options

Driving side	Lighting
Left	Normal/unknown

Arms

Arms

Arm	Name	Description	Arm type
A	A4260 Oxford Road South		Major
B	Site Access		Minor
C	A4260 Oxford Road North		Major

Major Arm Geometry

Arm	Width of carriageway (m)	Has kerbed central reserve	Has right turn bay	Width for right turn (m)	Visibility for right turn (m)	Blocks?	Blocking queue (PCU)
C - A4260 Oxford Road North	6.00		✓	2.60	200.0	✓	6.00

Geometries for Arm C are measured opposite Arm B. Geometries for Arm A (if relevant) are measured opposite Arm D.

Minor Arm Geometry

Arm	Minor arm type	Width at give-way (m)	Width at 5m (m)	Width at 10m (m)	Width at 15m (m)	Width at 20m (m)	Estimate flare length	Flare length (PCU)	Visibility to left (m)	Visibility to right (m)
B - Site Access	One lane plus flare	10.00	10.00	8.00	5.20	4.70	✓	3.00	150	150

Slope / Intercept / Capacity

Priority Intersection Slopes and Intercepts

Junction	Stream	Intercept (Veh/hr)	Slope for A-B	Slope for A-C	Slope for C-A	Slope for C-B
1	B-A	625	0.114	0.288	0.181	0.411
1	B-C	808	0.124	0.313	-	-
1	C-B	720	0.279	0.279	-	-

The slopes and intercepts shown above do NOT include any corrections or adjustments.

Streams may be combined, in which case capacity will be adjusted.

Values are shown for the first time segment only; they may differ for subsequent time segments.

Traffic Demand

Vehicle mix source	PCU Factor for a HV (PCU)
HV Percentages	2.00

Demand overview (Traffic)

Arm	Linked arm	Use O-D data	Average Demand (Veh/hr)	Scaling Factor (%)
A - A4260 Oxford Road South		✓	775	100.000
B - Site Access		✓	153	100.000
C - A4260 Oxford Road North		✓	888	100.000

Origin-Destination Data

Demand (Veh/hr)

		To		
		A - A4260 Oxford Road South	B - Site Access	C - A4260 Oxford Road North
From	A - A4260 Oxford Road South	0	48	727
	B - Site Access	57	0	96
	C - A4260 Oxford Road North	812	76	0

Vehicle Mix

Heavy Vehicle Percentages

		To		
		A - A4260 Oxford Road South	B - Site Access	C - A4260 Oxford Road North
From	A - A4260 Oxford Road South	0	0	1
	B - Site Access	0	0	0
	C - A4260 Oxford Road North	1	0	0

Results

Results Summary for whole modelled period

Stream	Max RFC	Max delay (s)	Max Queue (Veh)	Max LOS
B-C	0.21	9.15	0.3	A
B-A	0.33	28.63	0.5	D
C-AB	0.17	9.09	0.2	A
C-A				
A-B				
A-C				

Main Results for each time segment

11:45 - 12:00

Stream	Total Demand (Veh/hr)	Capacity (Veh/hr)	RFC	Throughput (Veh/hr)	End queue (Veh)	Delay (s)	LOS
B-C	72	610	0.119	72	0.1	6.686	A
B-A	43	327	0.131	42	0.1	12.639	B
C-AB	57	556	0.103	57	0.1	7.211	A
C-A	611			611			
A-B	36			36			
A-C	547			547			

12:00 - 12:15

Stream	Total Demand (Veh/hr)	Capacity (Veh/hr)	RFC	Throughput (Veh/hr)	End queue (Veh)	Delay (s)	LOS
B-C	86	567	0.152	86	0.2	7.487	A
B-A	51	268	0.191	51	0.2	16.520	C
C-AB	68	524	0.130	68	0.1	7.900	A
C-A	730			730			
A-B	43			43			
A-C	654			654			

12:15 - 12:30

Stream	Total Demand (Veh/hr)	Capacity (Veh/hr)	RFC	Throughput (Veh/hr)	End queue (Veh)	Delay (s)	LOS
B-C	106	500	0.211	105	0.3	9.104	A
B-A	63	188	0.333	62	0.5	28.236	D
C-AB	84	480	0.174	83	0.2	9.081	A
C-A	894			894			
A-B	53			53			
A-C	800			800			

12:30 - 12:45

Stream	Total Demand (Veh/hr)	Capacity (Veh/hr)	RFC	Throughput (Veh/hr)	End queue (Veh)	Delay (s)	LOS
B-C	106	499	0.212	106	0.3	9.148	A
B-A	63	188	0.333	63	0.5	28.631	D
C-AB	84	480	0.174	84	0.2	9.091	A
C-A	894			894			
A-B	53			53			
A-C	800			800			

12:45 - 13:00

Stream	Total Demand (Veh/hr)	Capacity (Veh/hr)	RFC	Throughput (Veh/hr)	End queue (Veh)	Delay (s)	LOS
B-C	86	565	0.153	87	0.2	7.524	A
B-A	51	269	0.191	52	0.2	16.704	C
C-AB	68	524	0.130	69	0.2	7.915	A
C-A	730			730			
A-B	43			43			
A-C	654			654			

13:00 - 13:15

Stream	Total Demand (Veh/hr)	Capacity (Veh/hr)	RFC	Throughput (Veh/hr)	End queue (Veh)	Delay (s)	LOS
B-C	72	609	0.119	72	0.1	6.714	A
B-A	43	327	0.131	43	0.2	12.724	B
C-AB	57	556	0.103	57	0.1	7.229	A
C-A	611			611			
A-B	36			36			
A-C	547			547			

Contact

RPS Consulting Services Ltd
20 Western Avenue
Milton Park
Abingdon
Oxfordshire OX14 4SH
T: +44(0) 1235 432190
transport@rpsgroup.com