

100  
 Millimetres  
 10  
 0  
 DO NOT SCALE

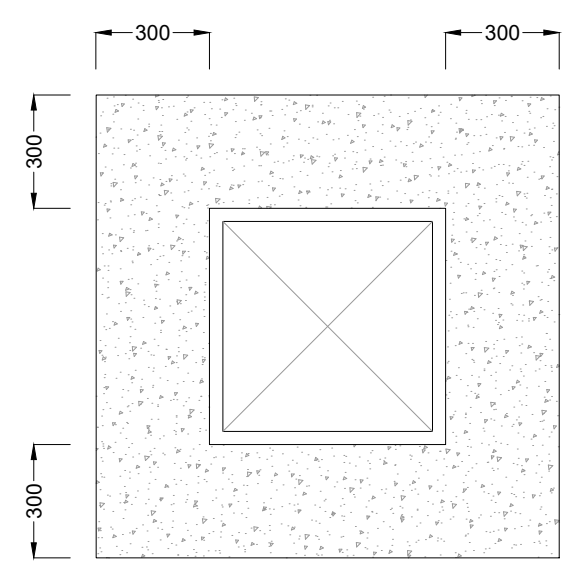

**PLAN VIEW**

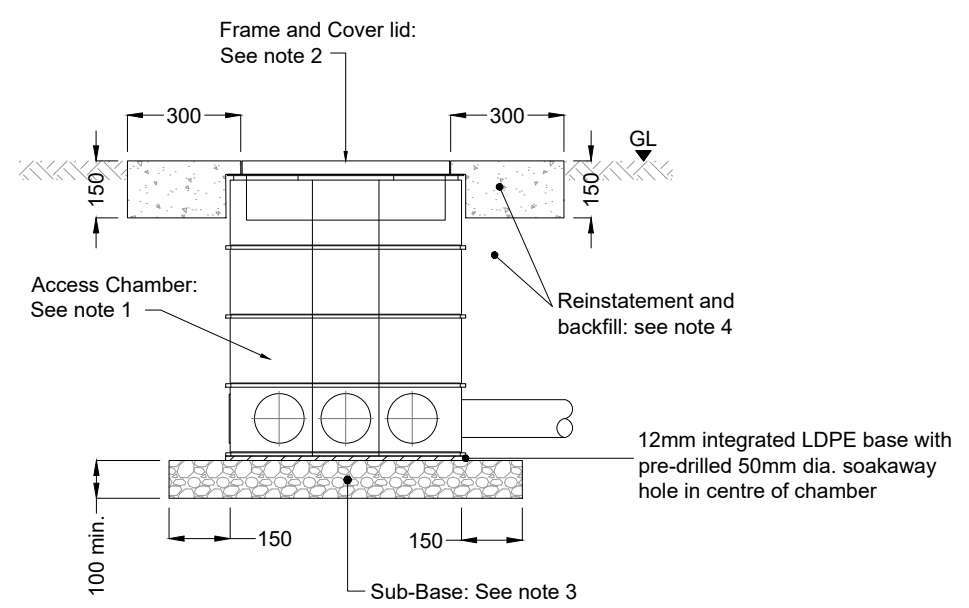

**'STYLE Y'**

- Notes:**
- 'Style Y' should use 12mm integrated LDPE base with pre-drilled 50mm diameter soak away hole in the centre of the chamber. The pre-formed chamber units shall have pre-trepanned knockout areas to accept 50mm / 100mm internal diameter ducting.
  - Access chamber frames and cover lids for 'Light Duty' applications shall comply with **BS EN 124, Class B 125 (12.5 tonnes)**. Refer to scheme drawings for application. Access chamber cover lid to be permanently inscribed with 'Traffic Signals'. Frames are to be secured to the chamber by means of bolts.
  - The chamber should be bedded on a base of 100mm minimum compacted SHW Type 2 sub-base.
  - The sides to be backfilled with acceptable general fill material. Reinstatement in Unmade Ground to utilize ST4 concrete surround, formed using shuttering to produce a squared off finish, level with surrounding ground. Surface to be brush textured, with a trowelled bullnose outer edge.
  - Refer to Drawing No. TSCADSTD-ATK-HTS-CHAMBER-DR-D-0003 for Access Chamber Details.
  - All dimensions in millimetres (mm) unless otherwise stated.

SAFETY, HEALTH AND ENVIRONMENTAL INFORMATION					
In addition to the hazards/risks normally associated with the types of work detailed on this drawing, note the following:					
CONSTRUCTION					
NONE					
MAINTENANCE/CLEANING					
NONE					
DECOMMISSIONING/DEMOLITION					
NONE					
It is assumed that all works will be carried out by a competent contractor working, where appropriate, to an approved method statement					
Rev.	Date	Description	By	Chk'd	App'd
P1	22.06.16	FOR INFORMATION	BPIJH	MY	BP

Drawing Status: **FOR INFORMATION**

Suitability: **S2**

**ATKINS**

Woodcote Grove  
Ashley Road  
Epsom  
Surrey  
KT18 5BW  
Tel: +44 (0)1372 726140  
Fax: +44 (0)1372 740055  
www.atkinsglobal.com

Copyright © Atkins Limited (2016)

Client: **ATKINS**

Project Title					
TRAFFIC SIGNAL CAD STANDARDS					
Drawing Title					
STANDARD DETAIL ACCESS CHAMBER INSTALLATION DETAIL IN UNMADE GROUND (LIGHT DUTY)					
Scale	Designed	Drawn	Checked	Authorised	
1:20	BP	JH	MY	BP	
Original Size	Date	Date	Date	Date	Date
A3	22/06/16	22/06/16	22/06/16	22/06/16	22/06/16
Drawing Number					
Project		Originator		Volume	
TSCADSTD - ATK - HTS -		CHAMBER - DR - D - 0006		TSCADSTD	
Location					Revision
					P1