

DO NOT SCALE FROM THIS DRAWING.  
USE WRITTEN DIMENSIONS ONLY.  
ANY DISCREPANCIES OR SUGGESTED  
REVISIONS TO BE REPORTED TO TAYLOR  
WIMPEY UK.  
DRAWING TO BE READ IN CONJUNCTION  
WITH LATEST TAYLOR WIMPEY NATIONAL  
CONSTRUCTION SPECIFICATION.

**Air Barrier Continuity:**  
Apply continuous ribbons of adhesive along top of wall. Apply  
expanding foam tape or sealant under the skirting & continuous bead  
of sealant to the back of the skirting prior to fixing. Where there is  
no skirting apply expanding foam tape or sealant between plasterboard  
& floor. Seal all penetrations in the plasterboard.

**LEGEND:**

1. Brickwork/stone cut to rake of roof.
2. Overhang formed by 150mm wide undercloak.
3. Compressed insulation quilt to top of gable and  
underside of roofing felt to close cavity.
4. Min 100mm wide mortar bedding with a mix of  
1:3 cement:sand with plasticiser.
5. Packer.
6. Level top of gable blockwork with mortar to  
correct pitch.

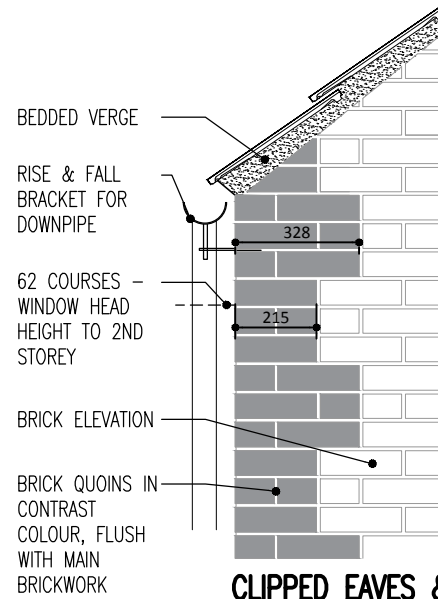

**CLIPPED EAVES & VERGE DETAIL**  
**BRICK ELEVATION WITH QUOINS**  
**SCALE 1:20**  
**ROOF PITCH VARIES**

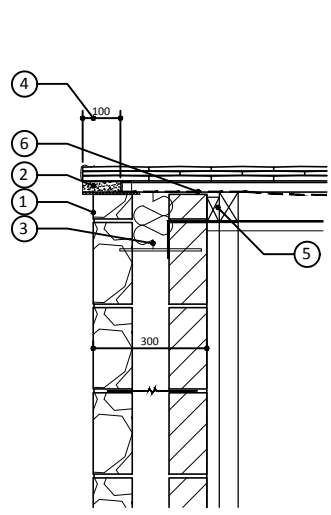
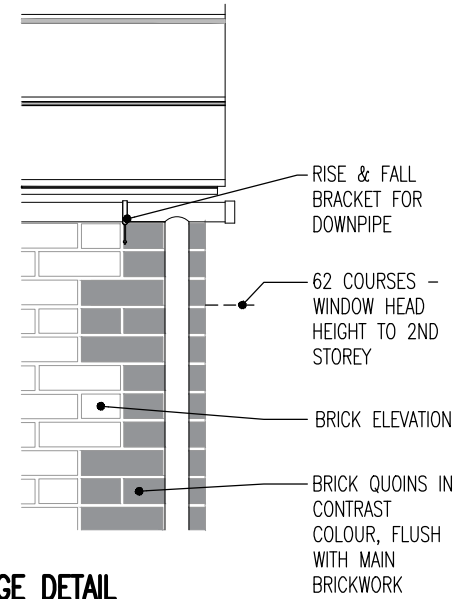

**PLAIN CLIPPED VERGE SECTION**

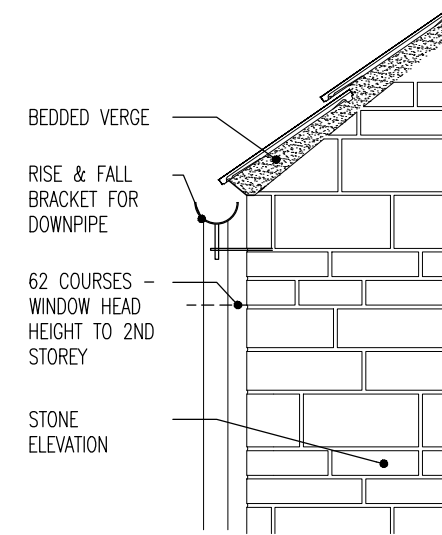

**CLIPPED EAVES & VERGE DETAIL**  
**STONE ELEVATION**  
**SCALE 1:20**  
**ROOF PITCH VARIES**

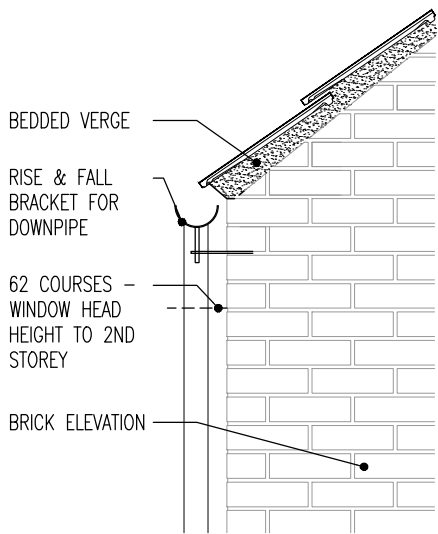
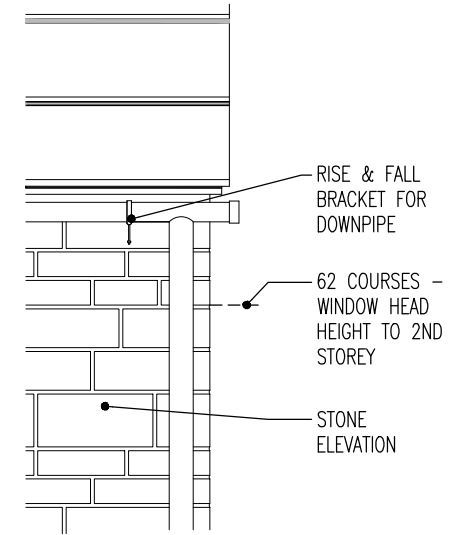

**CLIPPED EAVES & VERGE DETAIL**  
**BRICK ELEVATION**  
**SCALE 1:20**  
**ROOF PITCH VARIES**

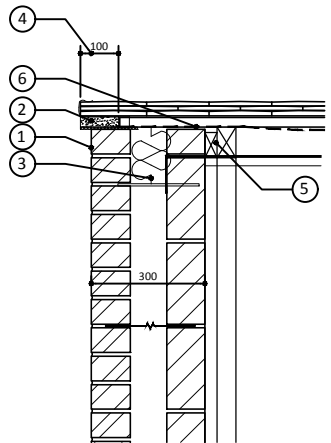
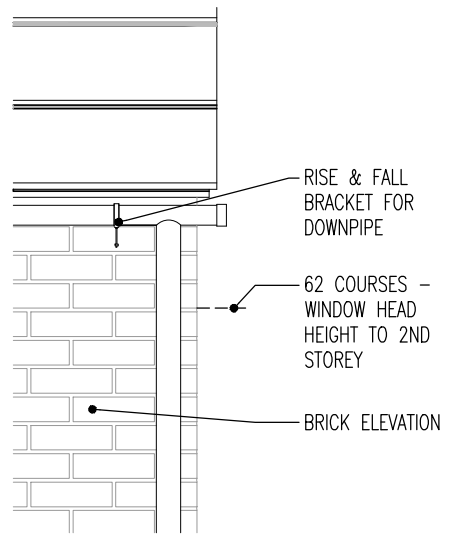

**PLAIN CLIPPED VERGE SECTION**

Date	Rev	Description
<b>Taylor Wimpey</b>		
Taylor Wimpey Oxfordshire, Windrush Court, Suite J, Abingdon Business Park, Abingdon, Oxfordshire, OX14 1SY t: 01235 541900 f: 01235 541901		
Project Title <b>AUDLEY GARDENS CHESTERTON</b>		
Drawing Title <b>EAVES AND VERGE DETAILS SHEET 1 OF 2</b>		
Date	Drawn	Checked
02/17	LSD	LSD
		Scale 1:20 @ A3
Consultant Preston Lodge Court, Preston Deanery, Northampton, NN7 2DS t: 01604 871199 e: info@lsdev.co.uk		
Drawing Number <b>LSD129.06.04</b>		Rev. -

