

**General Notes:**

1. This drawing is to be read in conjunction with other consultants drawings
2. Check site conditions prior to commencement of work
3. Discrepancies must be reported directly to the Architect
4. This drawing may be issued in colour, and may be a non-standard paper size

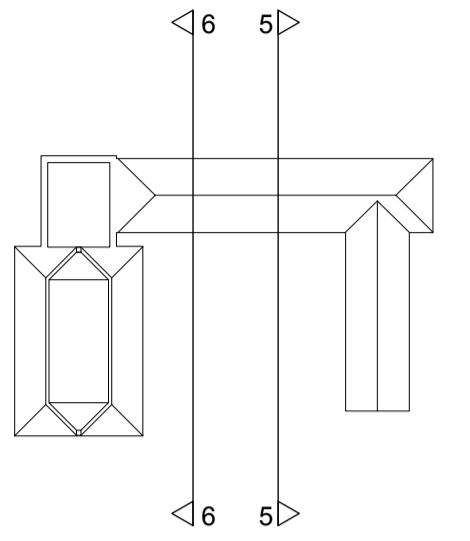

**Key**

- Demolitions
- Previous Scheme
- Proposed Walls
- Pitched Slate Roof
- Hand Made Brick
- Local Stone

**Materials**

Walls - Coursed local oolitic limestone with ashlar detailing and hand made multi red bricks with lime mortar pointing to lower wing.

Roof - Slate

Windows/Doors - Double glazed painted timber

Rain Water Goods - Painted Cast Iron

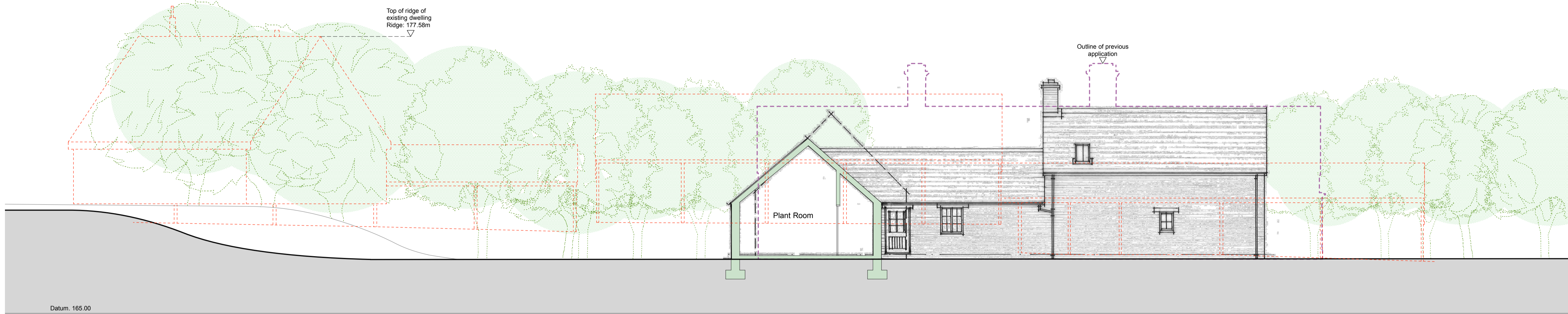

**5: West Section and Elevation**



**6: East Section and Elevation**

Rev	Date	Notes	Drawn
E	15.01.16	Revised planting layout	HM
D	07.01.16	Revised Design and Position	NQ
C	29.05.15	Parapet Omitted	NQ
B	05.01.15	Minor amendment - office window positions	NQ
A	12.12.14	Planning Issue	HM



QA Serial Number 26841



Client	Mr & Mrs. Besterman
Project Address	Muddle Barn Farm, Sibford Gower, Oxon, OX15 5RY
Project Description	Replacement Dwelling
Drawing Title	Proposed Site Elevations sh3 of 3
Drawing No.	1759.119
Rev.	E