

BELOW GROUND (BG) TREE SUPPORT SYSTEMS

1. EARTH ANCHORING: UNDISTURBED GROUND

Scale 1:20
PLAN VIEW

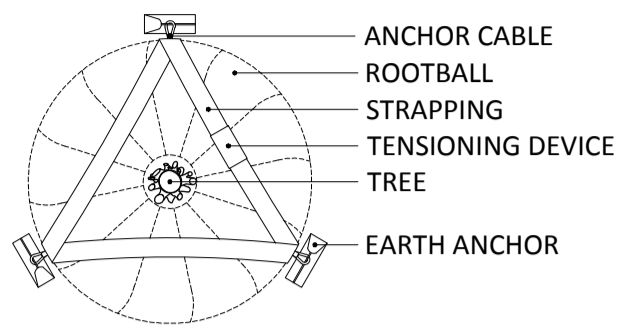

SECTION ELEVATION

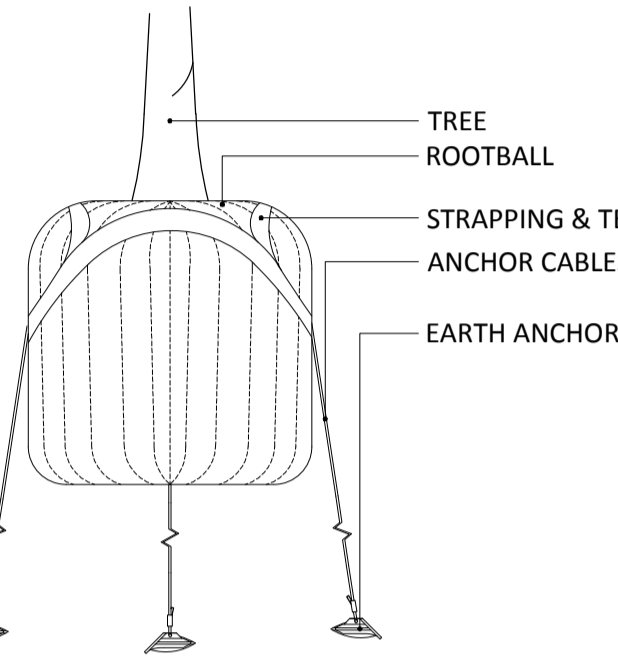

2. EARTH ANCHORING: DISTURBED GROUND AND/OR UTILITIES

Scale 1:20
PLAN VIEW

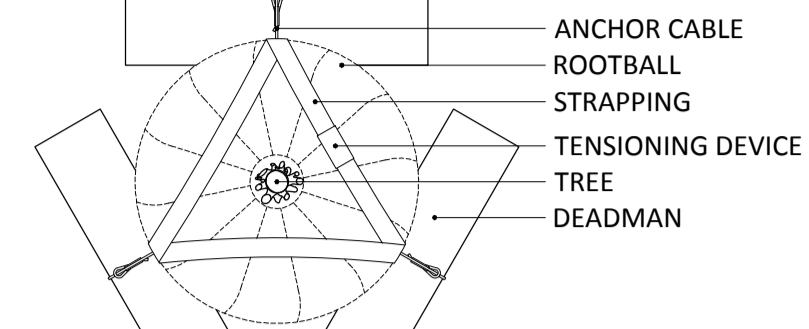

SECTION ELEVATION

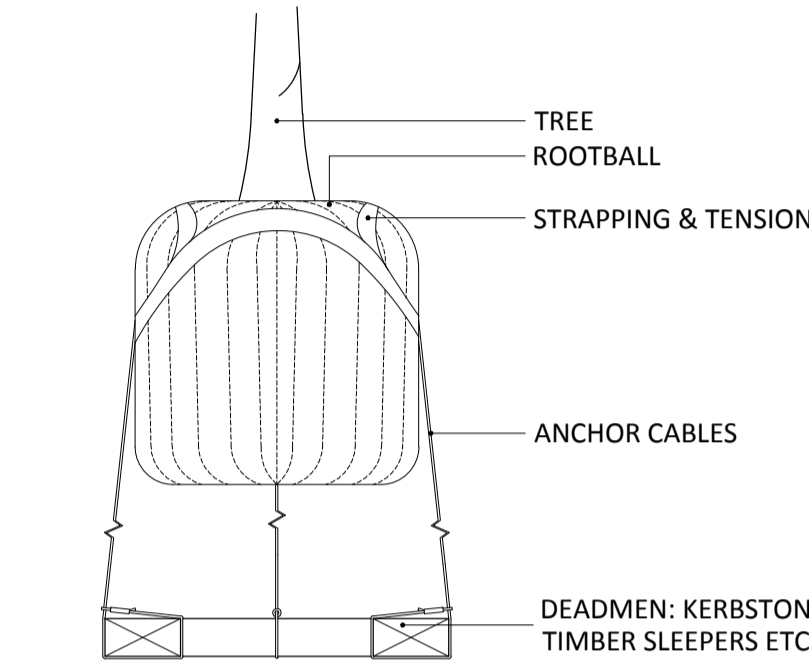

N.B. Earth Anchoring Systems are to be installed to manufacturer's recommendations & requirements with a minimum of 3no. earth anchors & associated cables to be fitted per tree.

3. PROPOSED TREE IRRIGATION PRINCIPLES: FOR ABOVE & BELOW GROUND TREE SUPPORT SYSTEMS

Scale 1:20
PLAN VIEW - BG

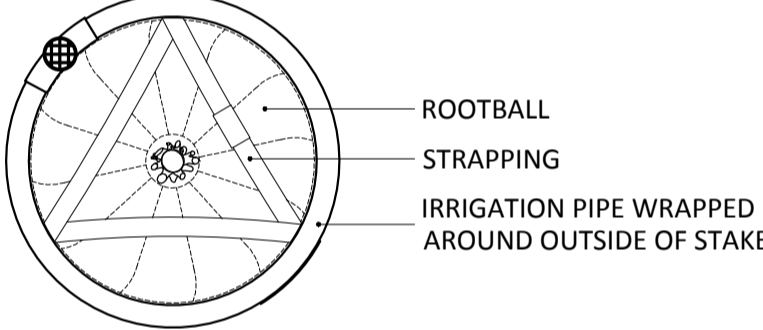

SECTION ELEVATION - BG

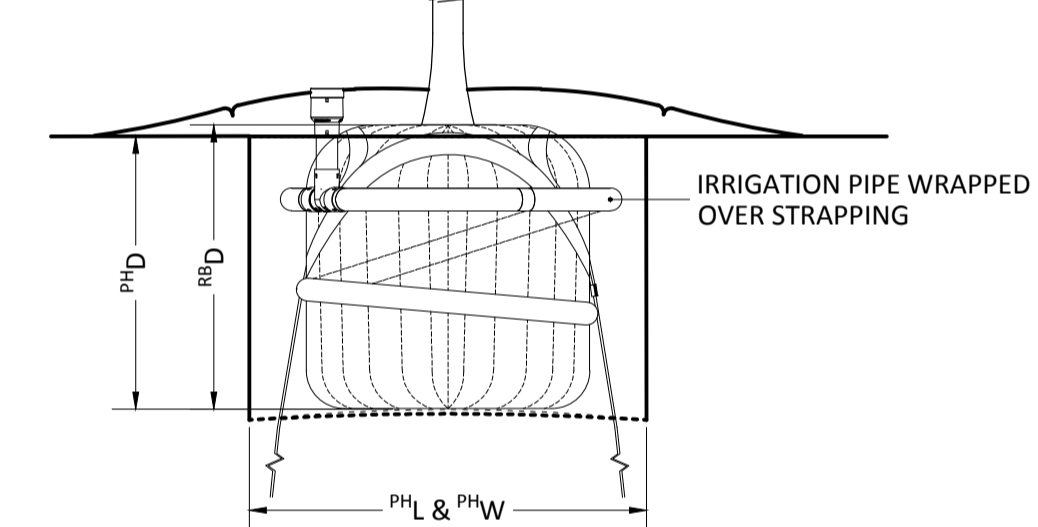

4. PROPOSED TREE PLANTING IN CONFINED SPACES SUBJECT TO PEDESTRIAN / VEHICULAR OVERRUN OVERLAIN W/T FLEXIBLE BLOCK PAVERS

Scale 1:20
PLAN VIEW

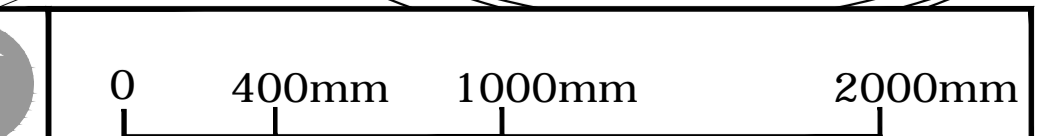
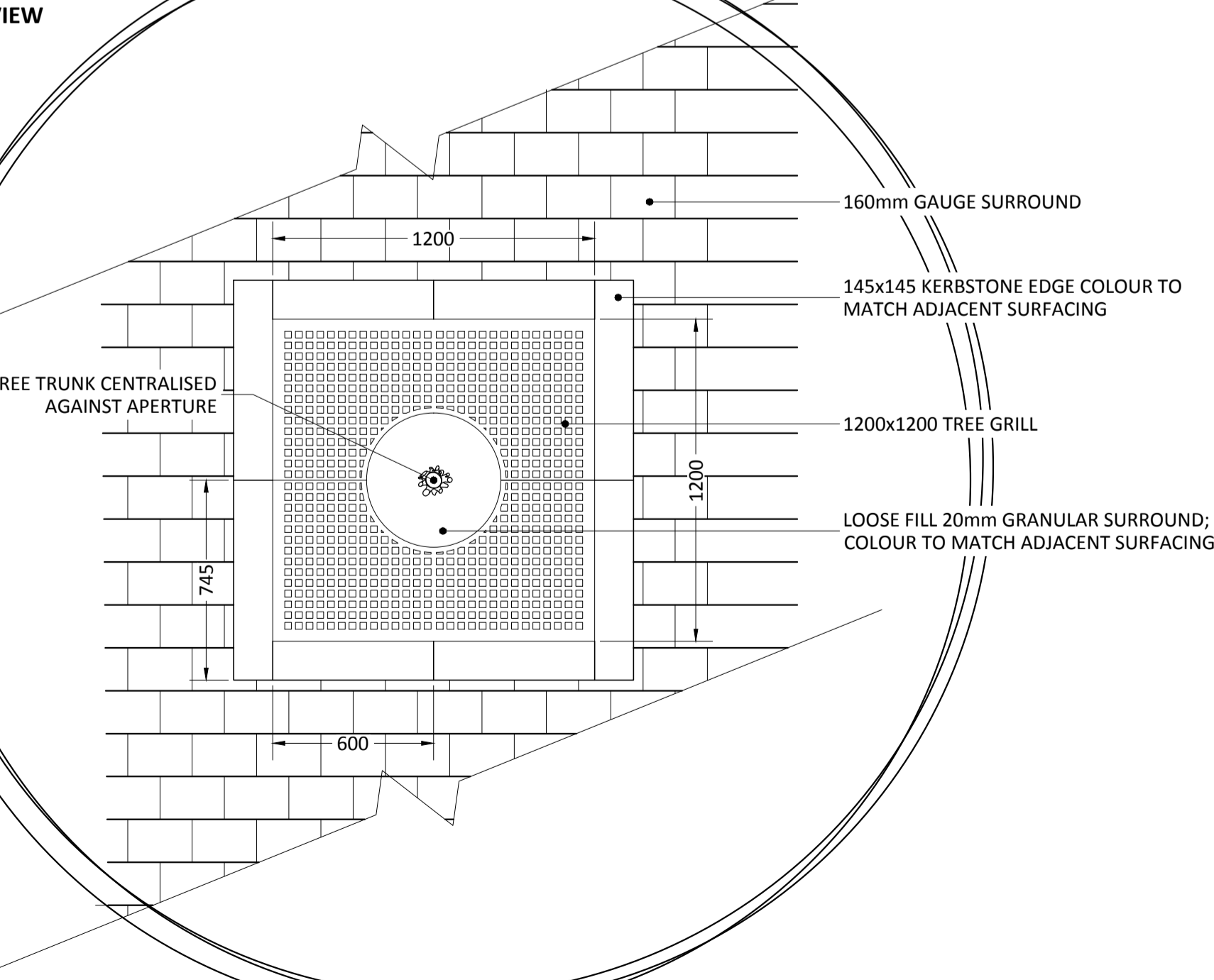

5. PROPOSED TREE PLANTING IN CONFINED SPACES SUBJECT TO PEDESTRIAN / VEHICULAR OVERRUN OVERLAIN W/T FLAGS

Scale 1:20
PLAN VIEW

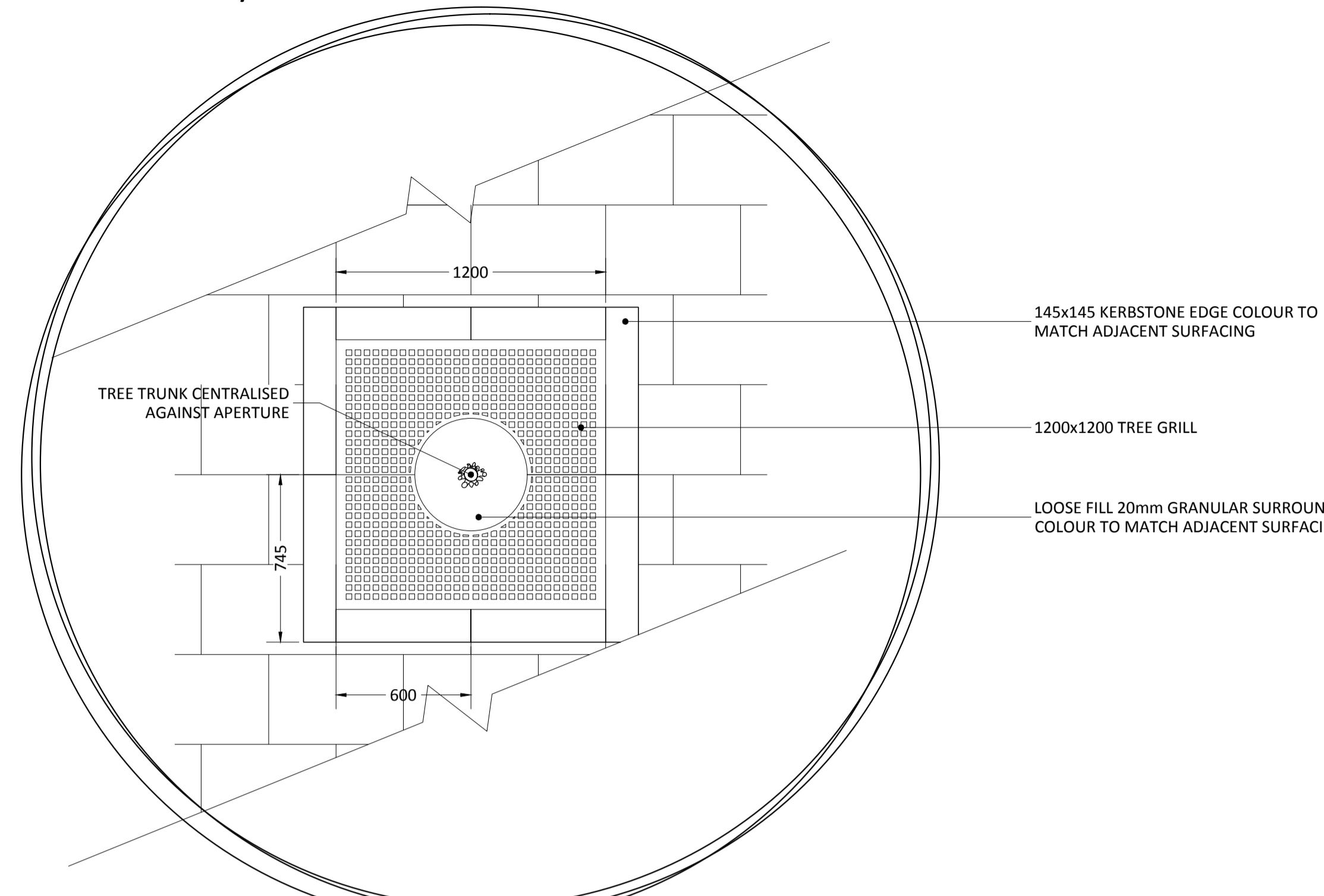

SECTION ELEVATION

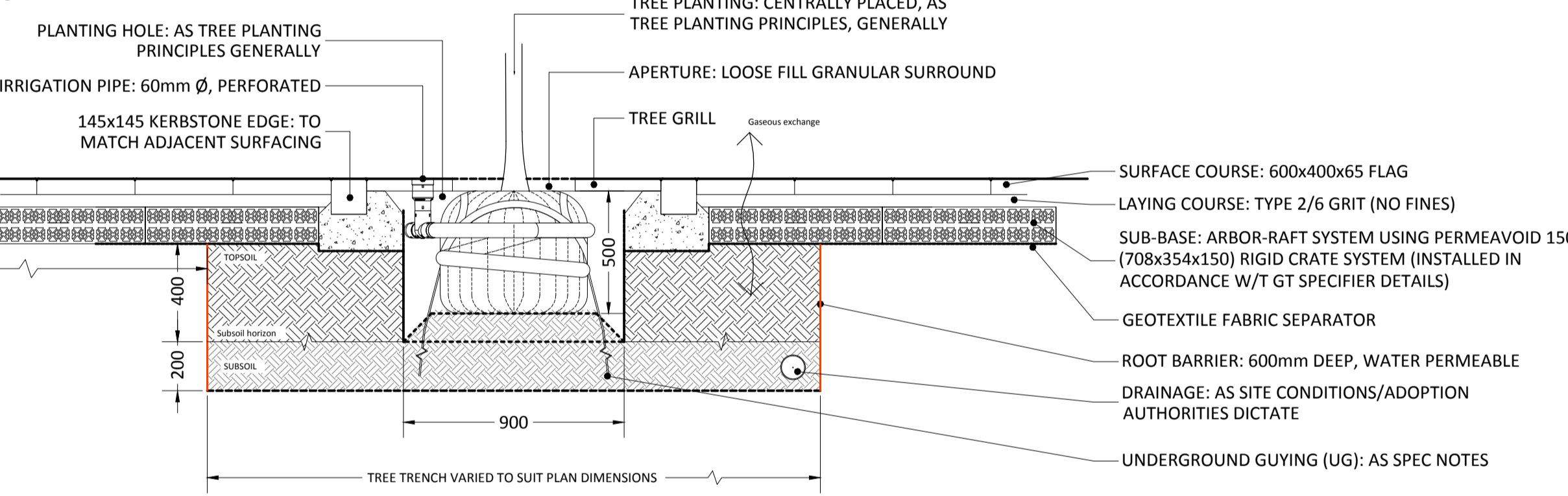

SECTION ELEVATION

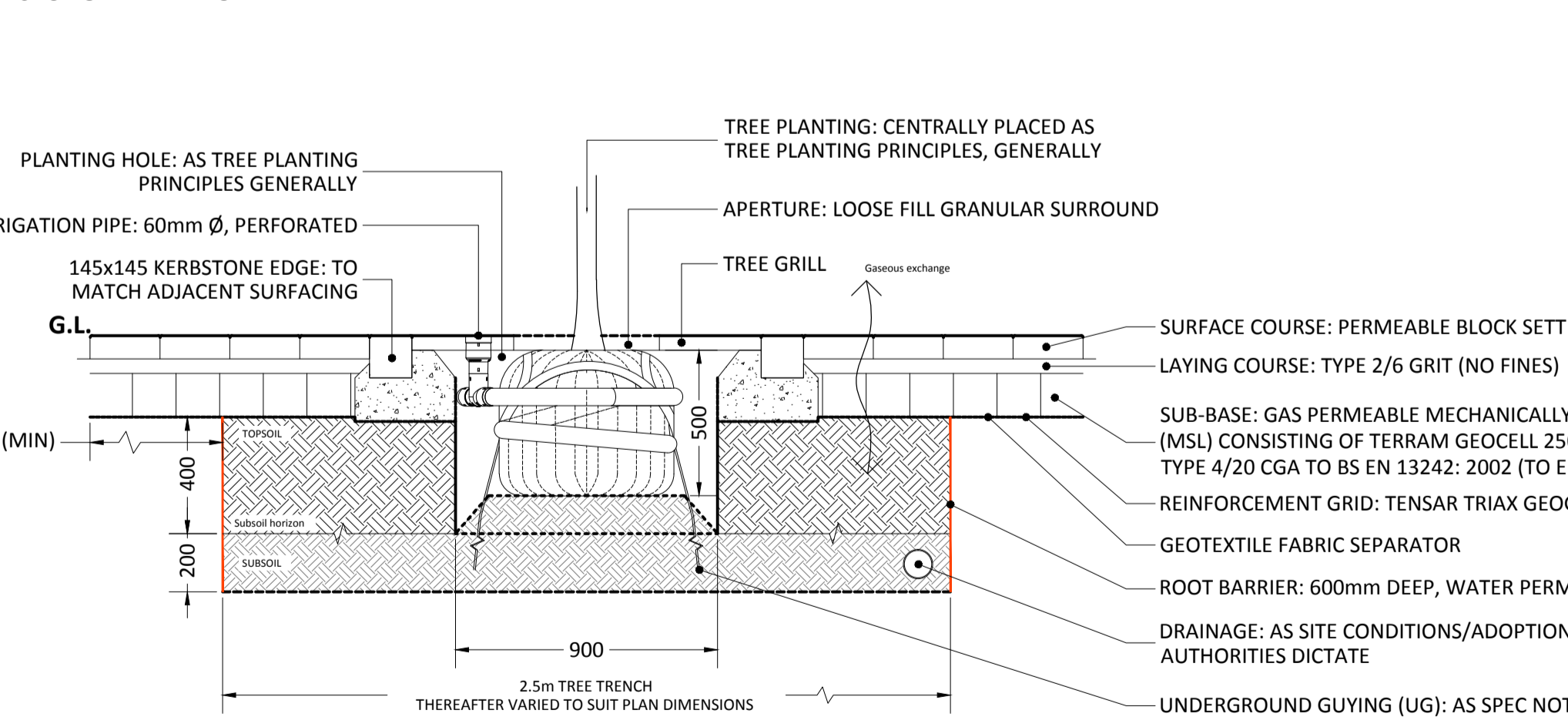

N.B.

- Diagram shows an EH 16-18cm tree.
- Trees in plan shown sharing a tree trench.
- Rootable volume limited by onsite constraints: service / utilities / highways etc.
- Plans shown are examples only, rootable area / geometry varies as dictated by site constraints.
- [Construction of] hard surfaces / kerbs / channels / edges to Engineer's structural engineering requirements & details.
- Tree support systems partially omitted for clarity.
- Sub-base may comprise: raft system such as: Type 4/20 Coarse Graded Aggregate (CGA), w/t a cellular confinement system and/or a Tensar Triax Geogrid, + fabric separators or; proprietary crate based system to provide void space to allow air pruning of roots.
- Rooting Environment: Clean general purpose topsoil to BS 3882: 2007 & subsoil to BS 8601: 2013. If deemed fit for purpose by the landscape contractor, subsoiling may not be required.

- GENERAL TREE PIT PLANTING NOTES:
- SPECIFIED MATERIALS:** all to be installed in accordance with the manufacturer's recommendations and/or instruction.
 - PLANTING GENERALLY:** Correct planting depth is critical for transplanting success, with over-deep planting identified as a common cause of failure. The Contractor shall therefore ensure that the natural root flare of the tree is clearly visible at proposed finished soiling surface. To ensure that correct final planting position / depth is achieved, the Contractor shall therefore take care to remove all:
 - soil placed above natural root flare during nursery packaging & production - rootballing, containerization, etc.
 - adventitious roots above the root flare,
 - wire encircling the main stem,
 - wire cage & burlap where possible. Otherwise, peel back and remove once the tree is in the planting pit.
 - BACKFILL MATERIAL:** Open ground: select 'as dug' material to be reused taking care to match adjacent soil horizons (where suitability assured for tree growth); TBC onsite by Contractor. All 'as dug' material to conform to BS 3882:2007 General Purpose Topsoil. Remove all deleterious material arising (weeds, broken brick & large stones, etc.). Hard Paved Surfacing: Use good quality topsoil to BS 3882: 2007 within primary rooting zone (rootcells) to manufacturer's instruction. Compact to manufacturer's recommendations. Backfill loose & dry (as approx. 20% is lost by volume upon compaction) into the tree pit. Lift in layers no greater than 300mm deep, and compact to between 1.5 - 2.0 mega pascals making sure the material is dry as proper compaction cannot be achieved when wet, paying special attention to the edges of the tree pit. A calibrated Penetograph can be used by a specialist approved by the soil supplier, and employed by the Contractor who installed the soil, to assess and confirm the level of compaction. The corresponding graph should be supplied to both the Project Structural Engineer, the Landscape Contractor & the Contract Administrator for information, before tree planting commences.
 - BACKFILL SOIL AMELIORANTS:** The Contractor shall satisfy himself of the general suitability of the top soil supplied for long term tree growth. Reason: to ensure the long term longevity of the tree supplied. Thereafter: TBC onsite.
 - ARISINGS:** all deleterious material arising, shall be removed offsite to a licensed tip by the Contractor.
 - TREE SUPPORT SYSTEMS:** Unless otherwise stated, all trees in hard surfaces open ground &/or verges will be supported using underground guying as identified by Detail 1 & 2 opposite.
 - Earth anchors to be driven, set and installed in accordance with the manufacturer's recommendations and/or instruction.
 - Earth anchors to include all rig 'd' straps, cables, cable tensioner & deadman anchors (kerbstones, timber sleepers etc.)
 - Underground guying (UG) systems (generally): supply & fit, Green Leaf Arbor guying system UG system (E, H, supply & fit: SASMP, 2 SM, supply & fit: SASLP.
 - In areas of made ground (Detail 2, 4 & 5), substitute: 'sluckball' earth anchors (Greenleaf SASMP / SASLP), with: deadman anchoring system (Greenleaf SASDMA, Platipus Deadman D-MAN system, etc).
 - Tensioning mechanisms and straps should be placed as shallowly as possible with only a light covering of the approved surfacing to avoid planting too deep. Tensioning mechanisms should be removed as soon as the developing root system is self supporting.
 - Irrigation pipes to be installed over the top of the BG tree support system.
 - ROOT PROTECTION MEASURES:** supply & install permeable rootbarriers (Terram RootGuard, or equal & approved) to a min. depth of 600mm below ground. Installation: as per manufacturer's instruction. Finished level: top of barrier to be 10mm above G.L. Zone of Deployment: protection of hard surfacing / services lying within a min. 5m radius of the proposed tree and or as dictated on plan.
 - IRRIGATION:** Supply & fit: Open ground: 60mm Ø flexible polypropylene perforated drainage pipe. Wrap twice around the rootball. Proposed supplier: Greenleaf Rootrain Urban, RRURBBA (or Equal & Approved). Hard paved surfacing: As per Tree Grill suppliers recommendations.
 - DRAINAGE:** the contractor shall satisfy himself that the tree pit is adequately drained, making adequate provision to do so where so required, and as site conditions dictate (i.e. supply & fit 100mm Ø, flexible, perforated polypropylene drainage pipe. Reason: to ensure the longevity & viability of the tree supplied. TBC onsite.

Notes
Issue: Drawn by David Jarvis Associates Limited (CROWN COPYRIGHT. ALL RIGHTS RESERVED 2011 LICENCE NUMBER 0100031). This drawing is for information purposes only - Do not use this drawing for construction.

Drawing Information: Information on this drawing is provided in the context of dwg information provided by: Hunters Architects (Site G.A. plan) & WSP Engineers (Car park G.A.).

Scaling: Do not scale this drawing. Use given dimensions only.

Construction Design Information: to Engineer's design, detail & specification.

Setting out: refer to Engineers for information regarding setting out. In the event of discrepancy, refer to the appointed Engineer in the first instance.

Construction Information: all detailed design (including, but not necessarily limited to, bond patterns, kerbing, edging, tactile crossing demarcation, construction build-up, levels, drainage etc., to be provided by an appropriately qualified structural/highways engineer to be appointed by the client for presentation to land subsquent discharge from the relevant supervising authority and/or body.

Planting: Plant species are selected and located in line with consideration of the site conditions, NHC guidelines and discussions with the Local Authority and design team. All plants and planting procedure to conform to the David Jarvis Associates Limited Landscape Specification that will accompany the Construction Issue drawings. No species or plant location is to be varied without prior consent of the Landscape Architect.

Foundations: Developers / Contractors to ensure that all foundations (buildings and external walls) are designed and constructed so as to take into account, at the time of maturity, any existing or proposed trees, hedgerows or other vegetation on the application site or existing vegetation on land adjoining the site at the time of construction and any trees felled or hedgerows removed on or adjacent to the site during the previous 15 years. For this purpose the developer / contractors will submit all relevant details to the authority dealing with the Building Regulations Certificate.

Rev	Date	Description
C	12/11/2015	Client name change
B	30/10/2015	Flag paving updated to match revised Hard Surface Strategy.
A	15/10/2015	Omit: structural tree soils reference within General Tree Planting Notes.
-	02/10/2015	First issue.

Drawing Status
PLANNING

DAVID JARVIS ASSOCIATES

DAVID JARVIS ASSOCIATES LIMITED
1 Tennyson Street Swindon Wiltshire SN1 5DT
Tel: 01793 612173 Fax: 01793 613625
Email: mail@davidjarvis.biz

Client
COUNTRYSIDE PROPERTIES (BICESTER) LTD.

Project
KINGSMERE, PHASE 1 LOCAL CENTRE

Drawing Title
TREE PLANTING IN HARD SURFACES

Scale	Sheet Size	Date
1:20	A1	OCT 2015
Drawing No.	Revision	
2226/LC/D007	C	