

DO NOT SCALE

NOTES:

1. ALL DIMENSIONS ARE IN MILLIMETRES UNLESS OTHERWISE STATED.
2. ALL CLAUSE NUMBERS REFER TO THE SPECIFICATION FOR HIGHWAY WORKS (SHW), LATEST EDITION.
3. ALL PRECAST CONCRETE UNITS ARE TO CONFORM TO AND BE LAID IN ACCORDANCE WITH CL.1101 OF THE SPECIFICATION FOR HIGHWAY WORKS LATEST EDITION.
4. KERB, BED AND BACKING SHALL BE ST2 GRADE CONCRETE TO CL.2602 OF THE SHW, LATEST EDITION.
5. CONSERVATION KERB FACE (CK) TO BE 160mm HIGH UNLESS OTHERWISE INDICATED.
6. TO BE 30mm WHEN ADJACENT TO THE GRASSED VERGE, AND 30mm PLUS THE DEPTH OF THE PAVING STONE WHEN ADJACENT TO PAVING STONES.
7. MECHANICAL HANDLING OF HEAVY ITEMS IS RECOMMENDED

TYPICAL WEIGHTS:
STANDARD PCC HB2 KERBS 69KG
CONSERVATION KERB 83KG
STANDARD PCC EDGING 45KG

REV	DATE	BY	DESCRIPTION	CHK	APP
E	26/03/10	LW	ISSUED FOR CONSTRUCTION	KW	GH
D	18/02/10	JH	OCC COMMENTS INCORPORATED	MHW	GH
C	03/12/08	JH	ISSUED FOR TECHNICAL APPROVAL	JAM	GH
B	30/05/08	JH	MINOR AMENDMENTS	LH	JM
A	11/03/08	JH	FIRST ISSUE	LH	JM

ISSUED FOR CONSTRUCTION

DRAWING STATUS:



Mountbatten House, Basing View, Basingstoke, Hampshire RG21 4HU
Tel: +44 (0)1256 318800 Fax: +44 (0)1256 318700
<http://www.wspgroup.com>

CLIENT: **COUNTRYSIDE PROPERTIES**

ARCHITECT:

PROJECT: **SOUTH WEST BICESTER
BICESTER, OXFORDSHIRE**

TITLE:

KERB TYPES SHEET 1 OF 2

SCALE @ AS	CHECKED:	APPROVED:
N.T.S	LH	JM

DAO FILE	DESIGN/DRAWN:	DATE:
1903-SD-210 (KERB)	PJ	January 2008

PROJECT No:	DRAWING No:	REV:
11011903	1903/SD/210	E

© WSP Group plc

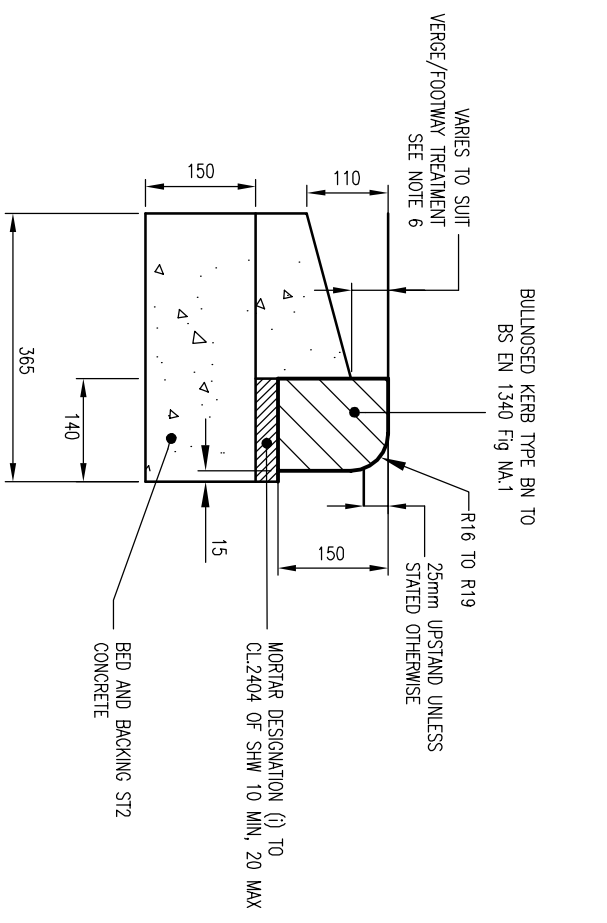

BULLNOSED KERB TYPE BN

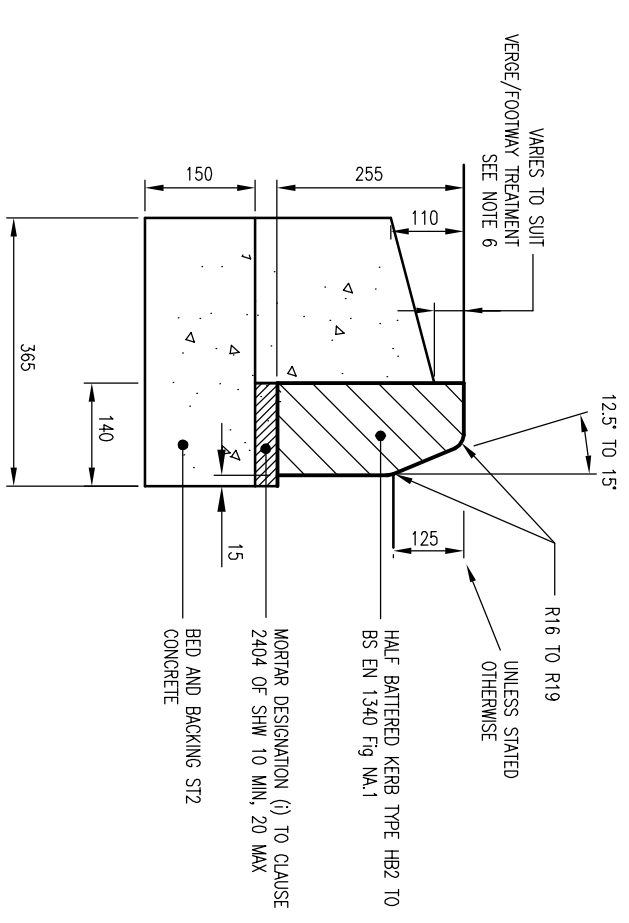

HALF BATTERED KERB TYPE HB2

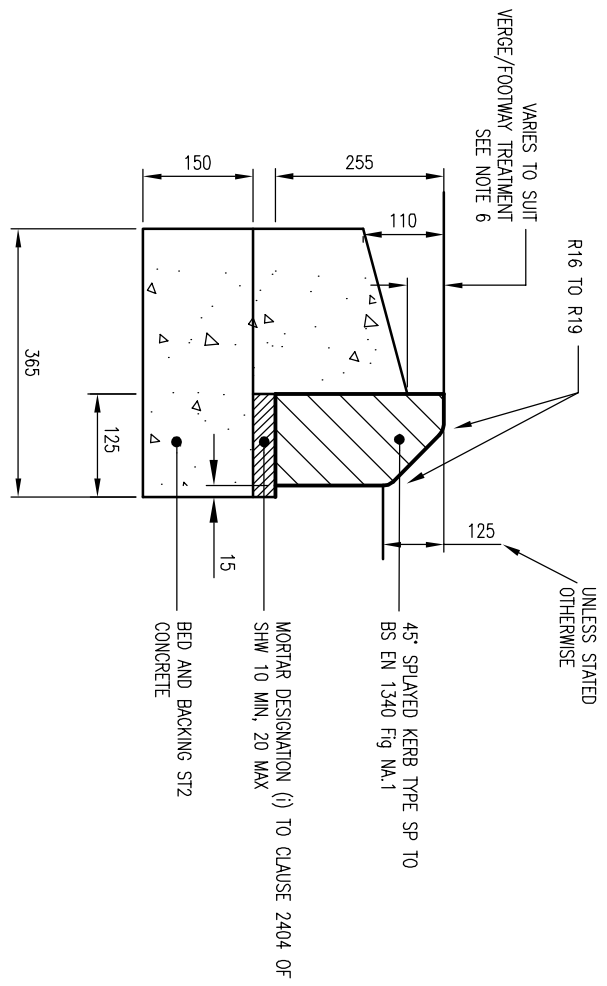

45° SPLOYED KERB TYPE SP

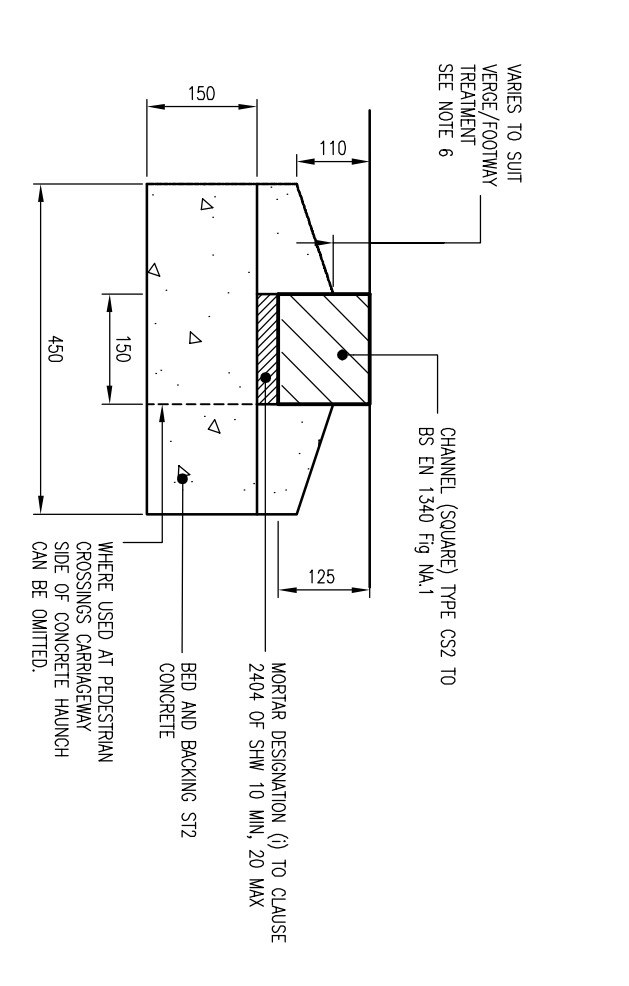

CHANNEL (SQUARE) TYPE CS2