

TRAFFIC CALMING TYPE A

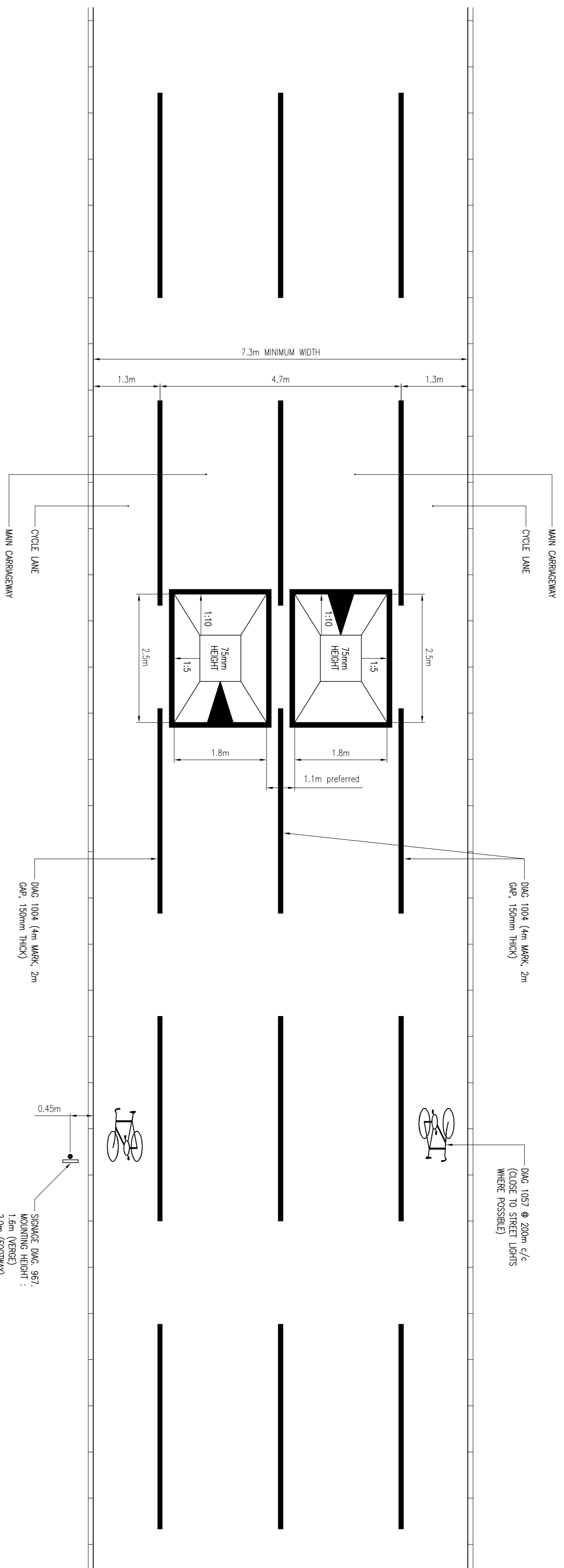

- DO NOT SCALE**
- NOTES:
1. THIS DRAWING SHOULD BE READ IN CONJUNCTION WITH ALL OTHER RELEVANT ENGINEERING DETAILS, DRAWINGS & SPECIFICATIONS.
  2. ALL DIMENSIONS ARE IN METRES UNLESS OTHERWISE STATED. SIMILARLY ALL LEVELS ABOVE DRAIN ARE ALSO IN METRES.
  3. PRIOR TO THE COMMENCEMENT OF CONSTRUCTION WORKS, EXISTING LEVELS AND DIMENSIONS ARE TO BE CHECKED AND CONFIRMED ON SITE.
  4. ANY DISCREPANCIES SHOULD BE REPORTED TO THE ARCHITECT/ENGINEER IMMEDIATELY SO THAT CLARIFICATION CAN BE SOUGHT PRIOR TO THE COMMENCEMENT OF WORK.

Signage Panel	Resistor	Width (mm)	675	Background Colour	Blue
Sign Reference	TS1	Height (mm)	480	Border	White
Material	100.0	Area (m <sup>2</sup> )	0.32	Legend	White
Class	R02				

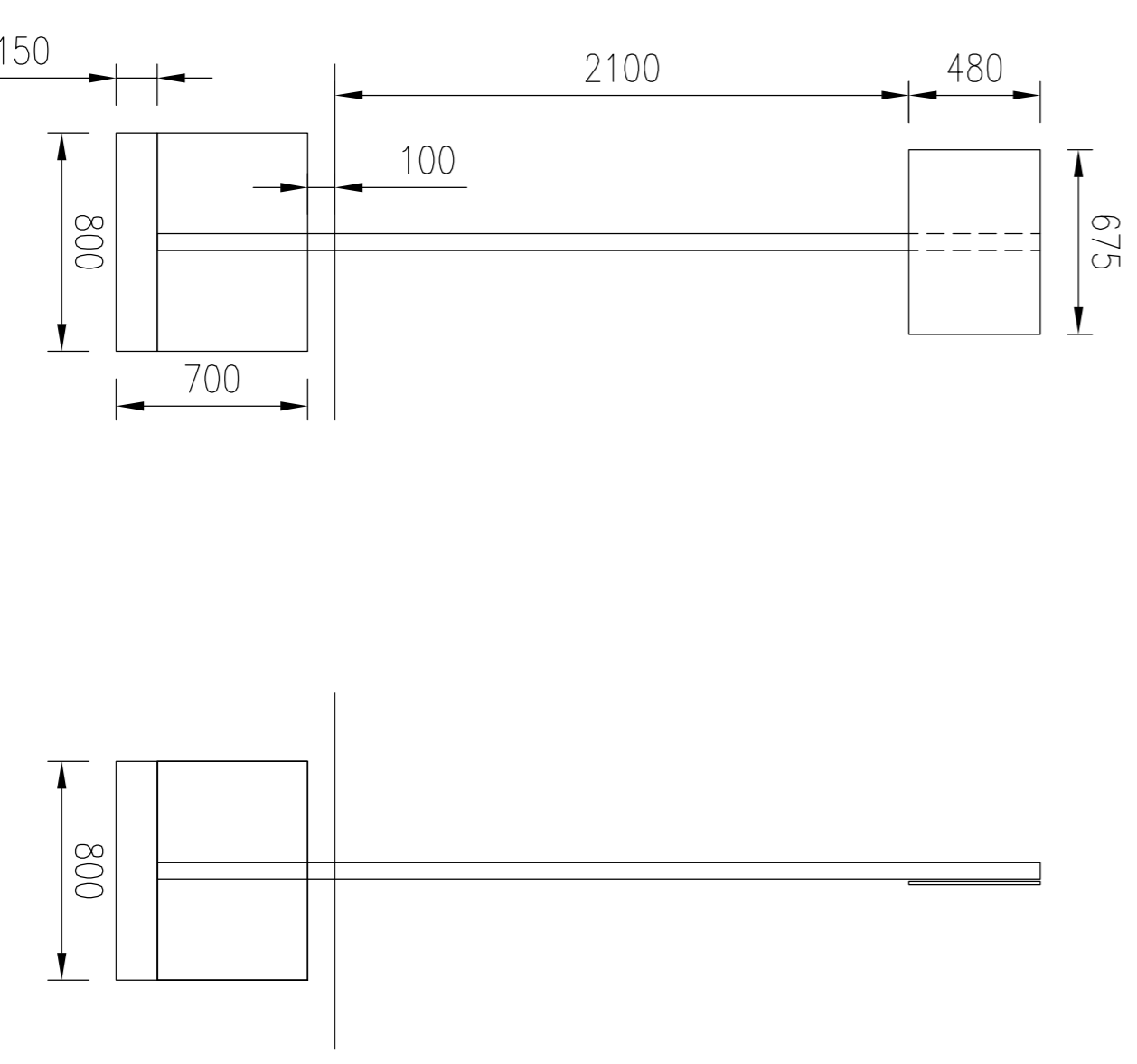

**Structural Calculation Details**

Sign: Reference Sign 1  
 Width: 675mm, Height: 480mm  
 Shape: Rectangular  
 Material: Steel  
 Mounted on post: 1 post  
 Mounting height: 2100mm

Posts: Quantity: 1  
 Type: 60.3 x 3.2 CHS  
 Spacing: N/A  
 Peak 1 Length: 3230mm

Base: Type: Combined  
 Width: 800mm  
 Height: 800mm  
 Volume: 0.528m<sup>3</sup>  
 Earth cover: 100mm  
 Bedding layer: 150mm

Typical Sign 1

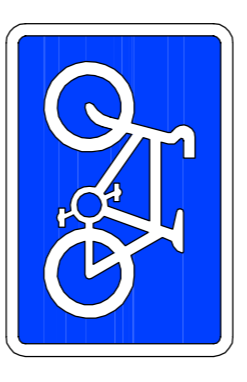

SIGNAGE DIA. 967.1  
 MOUNTING HEIGHT :  
 2.0m (FOOTWAY)  
 450mm OFFSET FROM KERB

<p>ISSUED FOR CONSTRUCTION</p>					
REV	DATE	BY	DESCRIPTION	CHK	APP
A	02/11/14	TRK	FIRST ISSUE (DRAWN FROM MSR-1042)	AC	AC
<p><b>PROJECT INFORMATION</b></p> <p>CLIENT: <b>COUNTRYSIDE PROPERTIES (BICESTER) LTD.</b></p> <p>PROJECT: <b>BICESTER</b></p> <p>ADDRESS: <b>Moundaton House, Basing View, Basingstoke, Hampshire RG21 4HU</b>                  Tel: +44 (0)1256 318800 Fax: +44 (0)1256 318700                  http://www.wspgroup.com</p> <p><b>WSP</b></p>					
<p><b>PROJECT TITLE</b></p> <p>MIDDLETON STONEY ROAD                  TRAFFIC CALMING DETAILS - SPEED CUSHION DETAILS                  SHEET 2 OF 2</p>					
<p>SCALE @ 1:1</p> <p>CHECKED: AD                  DATE: 1903-MSR-SD-102</p>		<p>APPROVED: AD                  DATE: November 14</p>		<p>PROJECT NO: 11011903</p> <p>DRAWING NO: 1903MSRSD/102</p> <p>REV: A</p>	
<p>© WSP Group plc</p>					