

Notes

- The wiring in the base compartment shall be neatly cleated to one side of the base board with sufficient tail length to connect into to cut out.
- Insulated connector blocks are to be provided in the base for termination of the cables being looped.
- All apparatus shall be securely fixed at all designated points to a back board or housing by stainless steel screws. All earth connections shall be bolted crimped terminations.
- All lanterns to be prewired by manufacturer using 3 core flex cable 1.5mm<sup>2</sup>.

**TABLE 2 SON**

No. of lamps	1	2	3	4	5	6
50W	6	6	6	6	6	6
70W	6	6	6	6	6	10
100W	6	6	6	6	10	10
150W	6	6	10	10	16	16
250W	16	16	16	20	20	20
400W	16	20	20	25	25	32
1000W	20	25	32	40	50	63

Maximum cable capacitance for SON circuits.

Recommended fuse ratings (in Amps) for multiple lamp installations of SON lamps for 240V 50 Hz supplies (B.S. 88 fuses)

**TABLE 3 LED**

No. of lamps	1	2	3	4	5	6
≥ 20W LED	6	6	6	6	6	6
≥ 35W LED	6	6	6	6	6	6
≥ 60W LED	6	6	6	6	6	6
≥ 100W LED	6	6	6	6	6	6
≥ 140W LED	6	10	10	16	20	25
+ 200W LED	6	16	16	20	25	25

**TABLE 4**

Fluorescent Lamps and Group Control Points (BS. 88 fuses)

(i) Sign lanterns all types 6 Amps

(ii) Subway installations and groups control points. Fuse to be appropriate to total circuit load.

**TABLE 5**

Zebra beacon installations and School signals 6 Amp BS fuse.

Index	Date	Category
e	Tables 1 & 3 changed note 4 added note 1 removed	01.14
d	Re-issued	06.99
c	Re-issued	03.97
b	Table 5 added	10.95
a	Fusing requirements added	02.92

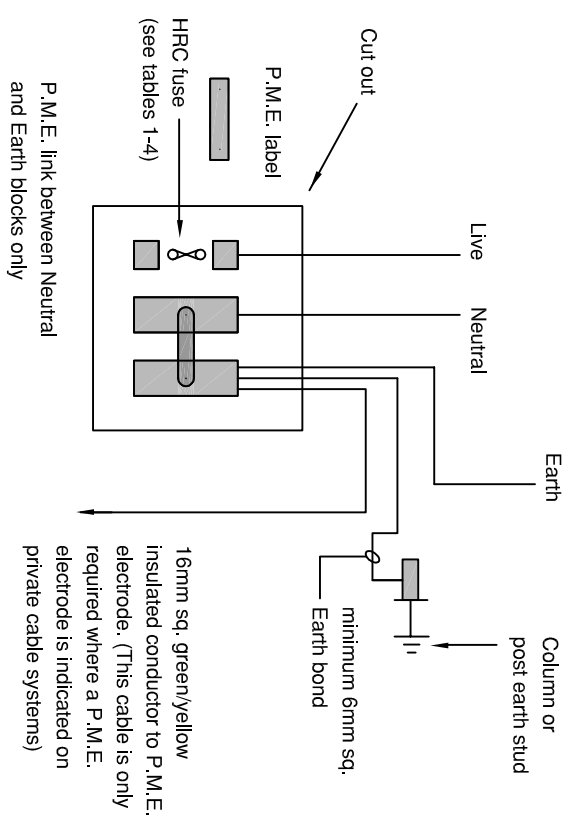

**GENERAL CUT OUT WIRING ARRANGEMENT FOR COLUMNS AND ILLUMINATED SIGNS**

**TABLE 1 CPO**

No. of lamps	1	2	3	4	5	6
45W CPO	6	6	6	6	6	6
90W CPO	6	6	6	10	10	10
140W CPO	16	16	16	20	20	20
160W CPO	16	20	20	25	25	25
+200W CPO	16	20	25	32	32	40

Recommended fuse ratings (in Amps) for multiple lamp installations of CPO lamps for 240V 50 Hz supplies (B.S. 88 fuses)

Fuse requirements (Tables 1-5)

**WIRING DETAILS : Fusing requirements and cut out details for columns and illuminated signs**

Scale	Initials		Date	
	Drawn	Traced	Checked	
Not to Scale				