



Middleton Stoney Road

Sign indicating left hand turn only when leaving site, si milar when entering site by right hand turn only

Proposed Speed Cushions

6m turning radius

10m wide section of hedge to be cleared to allow entrance construction

1.0m clearance from Lamp Post

Post & Board Fence Over Culvert

EXISTING SEWERS

Access at front of site left open, with main gates to material store and car park access to be lockable.

Heras Fencing

KM4 DEVELOPMENT SITE

Site compound FW drainage to connect to adoptable sewers being constructed by Bovis as part of the KM4 Development

MATERIAL STORE

CAR PARK

KM4 SITE COMPOUND

VEHICLE TURNING AREA

EXISTING SEWERS

EXISTING SEWERS

Adoptable sewers being constructed by Bovis as part of the KM4 Development

CHERWELL DISTRICT COUNCIL
 Plan No 15/009220/F
 Amended/Additional plans received 24.6.15 with Applicants/Agents
 Letter dated 23.6.15

Road constructed as part of KM3 Development

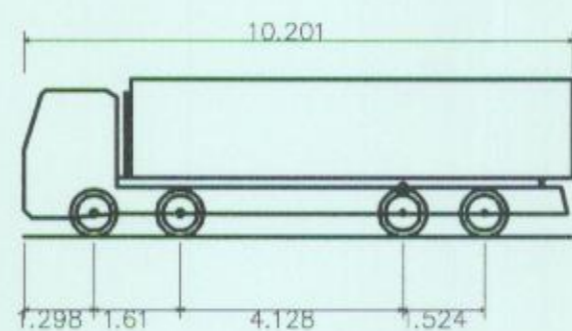

Large Tipper
 Overall Length 10.201m
 Overall Width 2.500m
 Overall Body Height 2.893m
 Min Body Ground Clearance 0.343m
 Max Track Width 2.500m
 Lock to Lock Time 6.00s
 Kerb to Kerb Turning Radius 11.550m

Bovis Homes Central Region
 Bromwich Court
 Highway Point
 Gorsey Lane
 Coleshill
 B46 1JU
 Tel: 01675 437 000
 Fax: 01675 437 094
 DX: 728340 Coleshill 2

SITE KM4
 Bicester

DRAWING TITLE Swept Path Analysis

DRAWN BY	DATE	DRAWING NO.	REV
CB	09.07.2014	BICE-5-1003	-
SCALE:	CHECKED/DATE		
1:250 @ A1			