

Floor Plan

LV SUBSTATION HOUSING LAYOUT
1:50

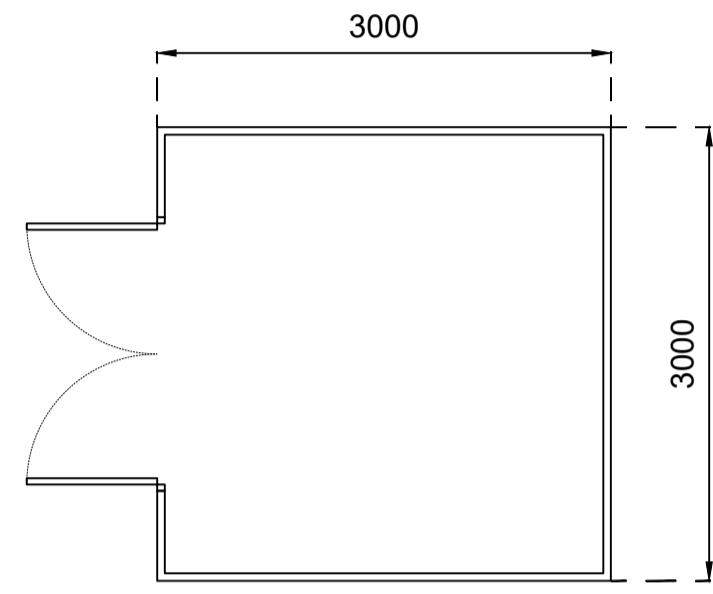

Floor Plan



Roof Plan

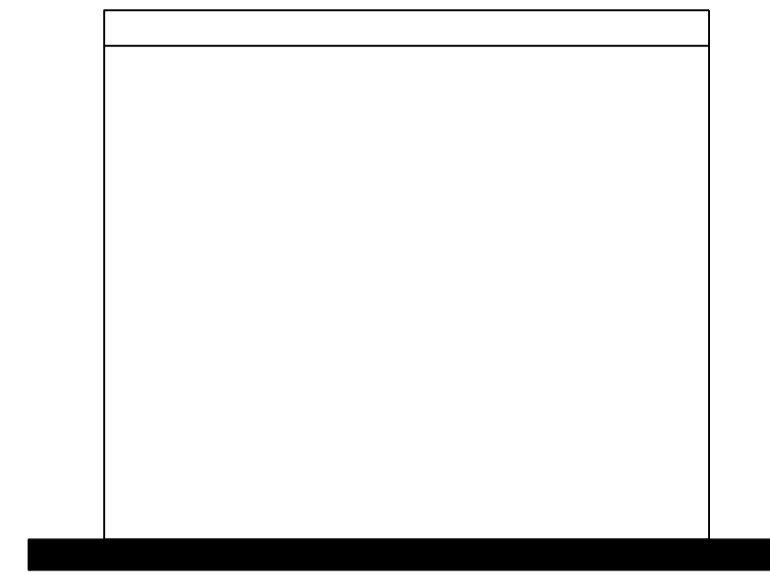

Front Elevation

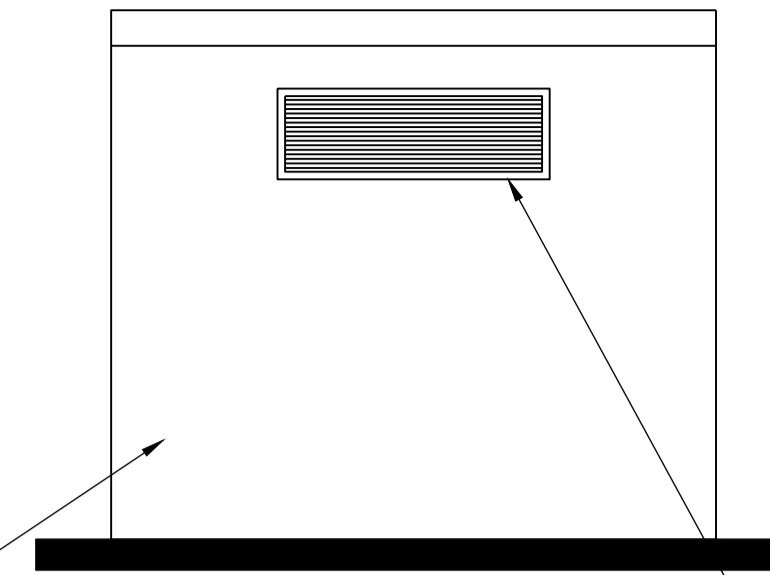

Rear Elevation

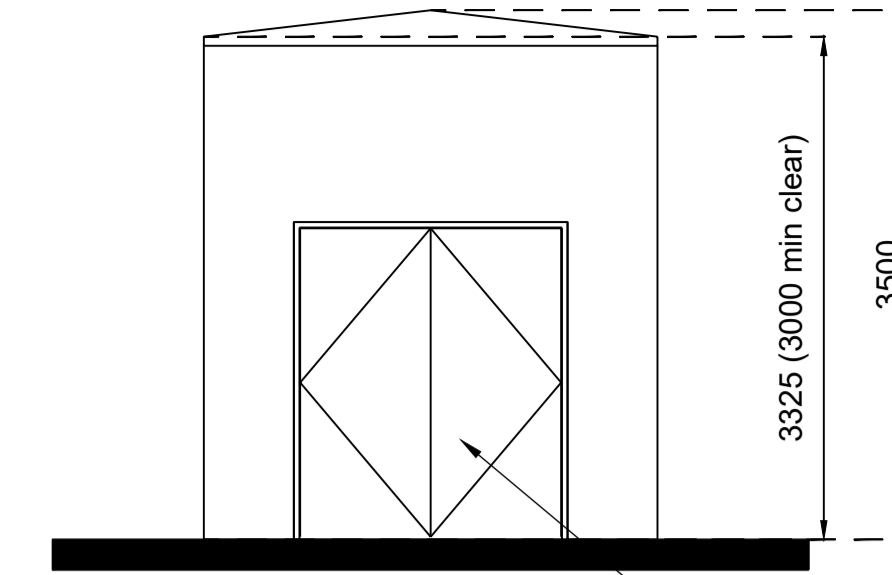

Left Elevation



Roof Plan

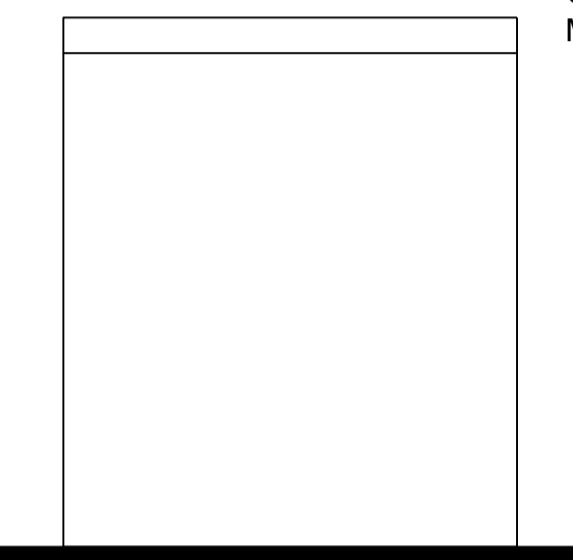

Front Elevation

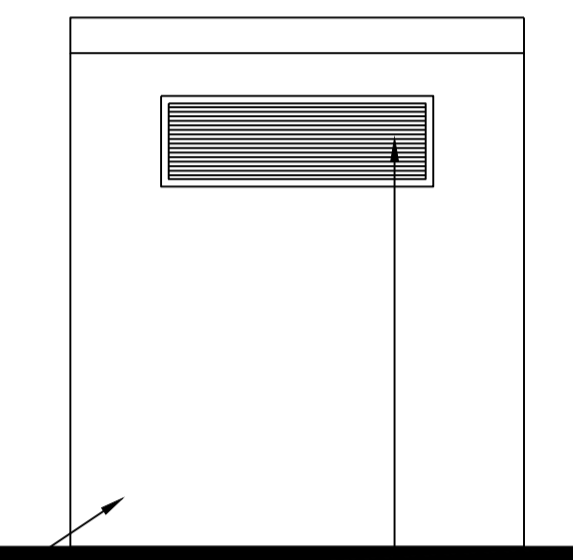

Rear Elevation

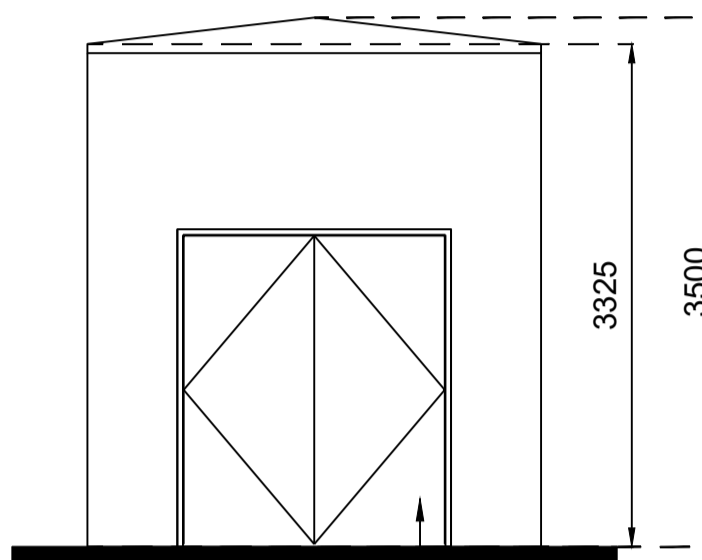

Left Elevation

GRP SUBSTATION HOUSING
COLOUR: RAL 6005
MOSS GREEN

VENTILATION GRILLE
TO SUBSTATION
SUPPLIER DETAILS

GRP LOCKABLE
DOORS, COLOUR TO
MATCH UNIT

GRP SUBSTATION HOUSING
COLOUR: RAL 6005
MOSS GREEN

VENTILATION GRILLE
TO SUBSTATION
SUPPLIER DETAILS

GRP LOCKABLE
DOORS, COLOUR TO
MATCH UNIT

HV / TX SUBSTATION HOUSING LAYOUT
1:50

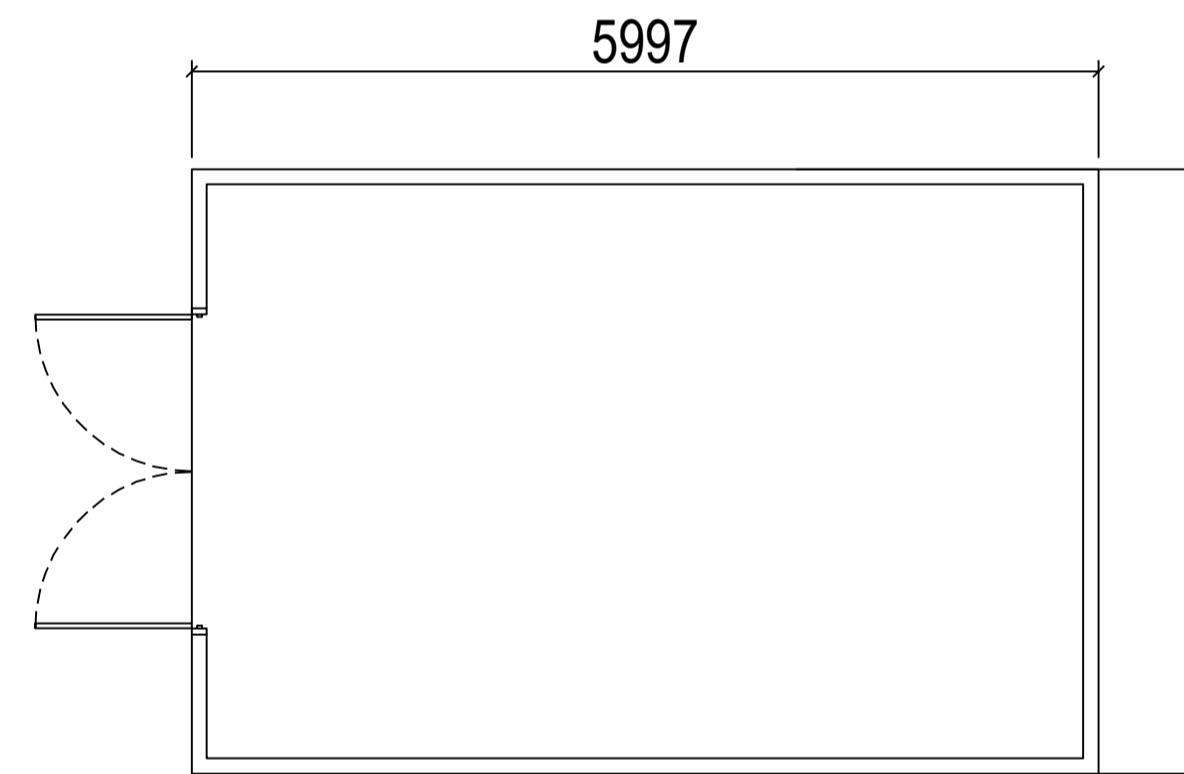

PLAN VIEW

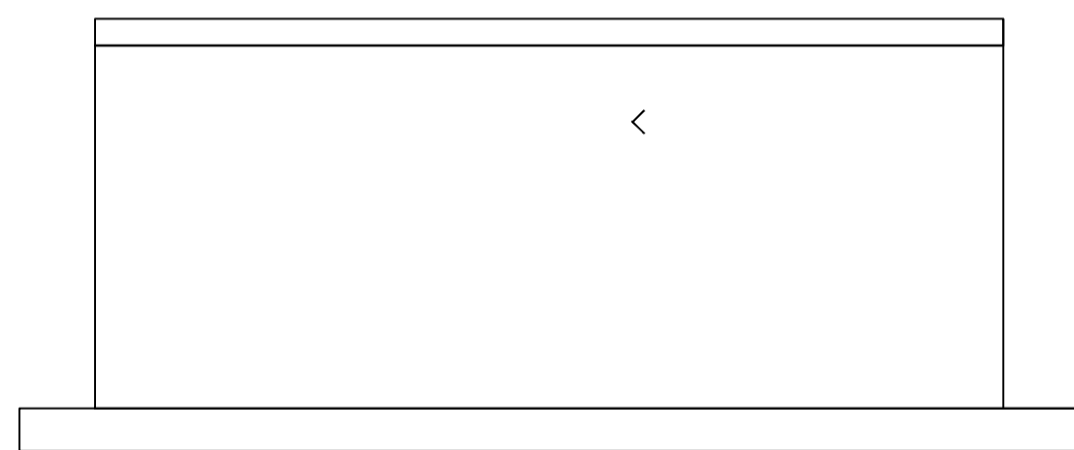

1 - FRONT ELEVATION

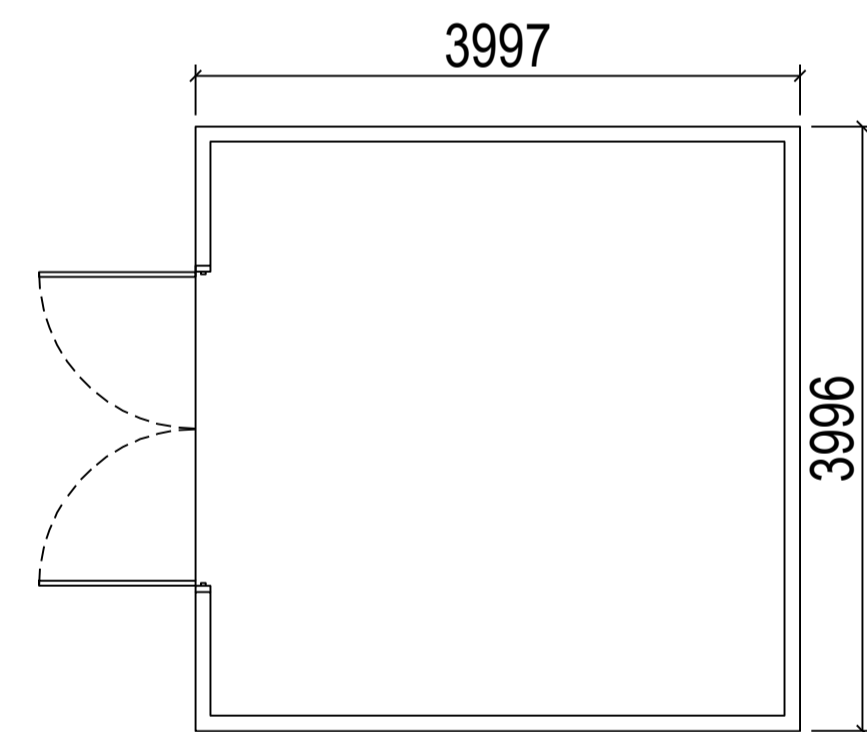

PLAN VIEW

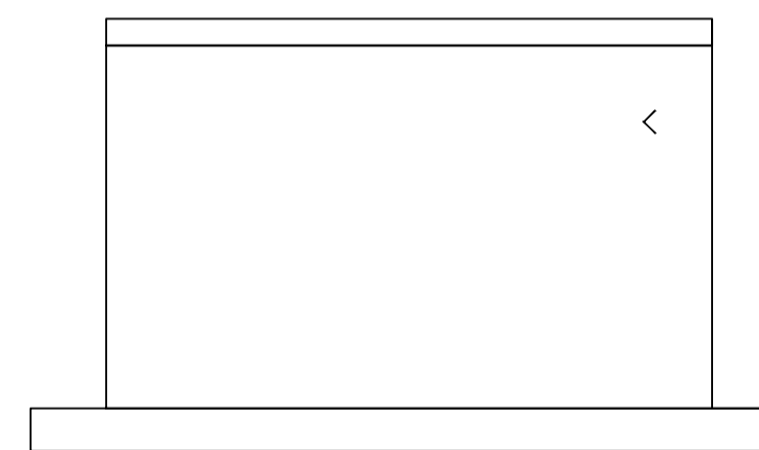

1 - FRONT ELEVATION

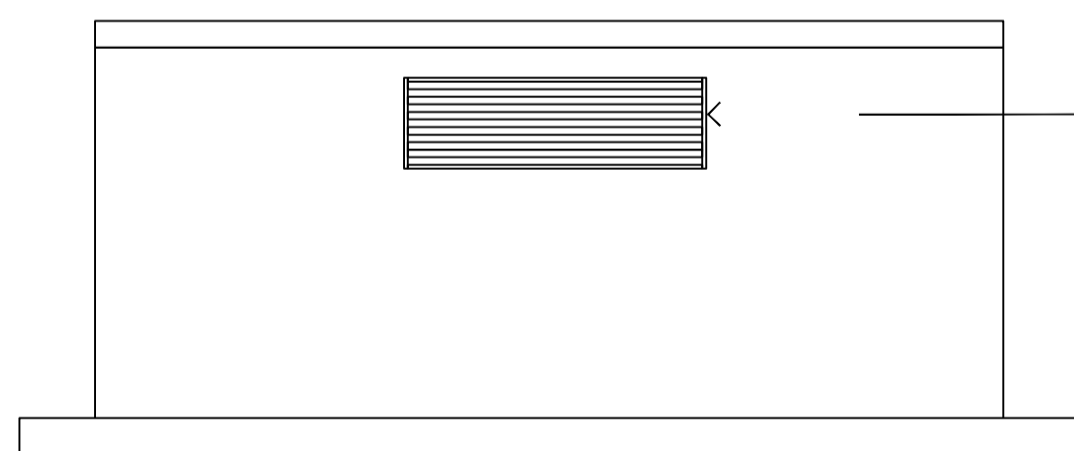

3 - REAR ELEVATION

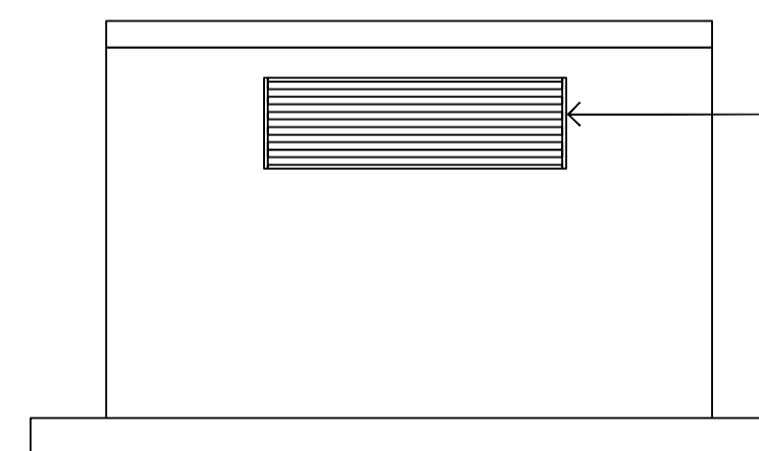

3 - REAR ELEVATION

GRP SUBSTATION HOUSING
COLOUR: DARK GREEN

GRP SUBSTATION HOUSING
COLOUR: DARK GREEN

VENTILATION GRILLS TO
SUBSTATION
SUPPLIER DETAILS

VENTILATION GRILLS TO
SUBSTATION
SUPPLIER DETAILS

GRP SUBSTATION HOUSING
COLOUR: DARK GREEN (RAL 6005)

GRP LOCKABLE DOORS
COLOUR TO MATCH UNIT

GRP SUBSTATION HOUSING
COLOUR: DARK GREEN (RAL 6005)

GRP LOCKABLE DOORS
COLOUR TO MATCH UNIT

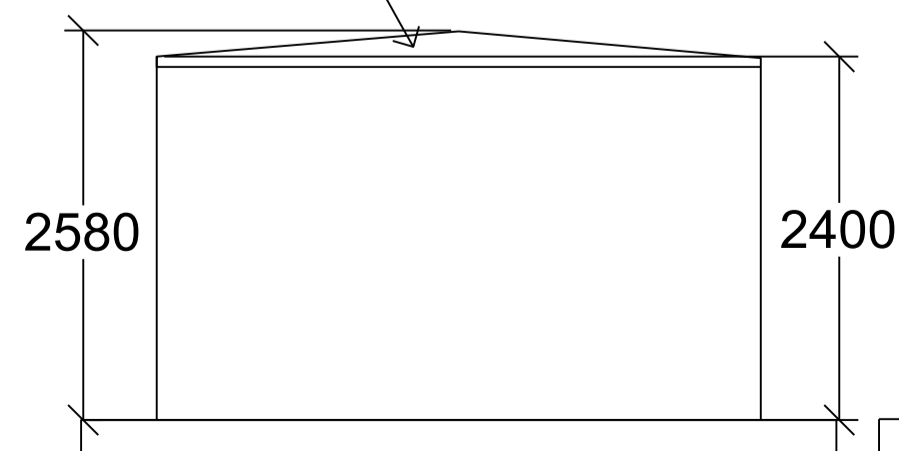

2 - SIDE ELEVATION

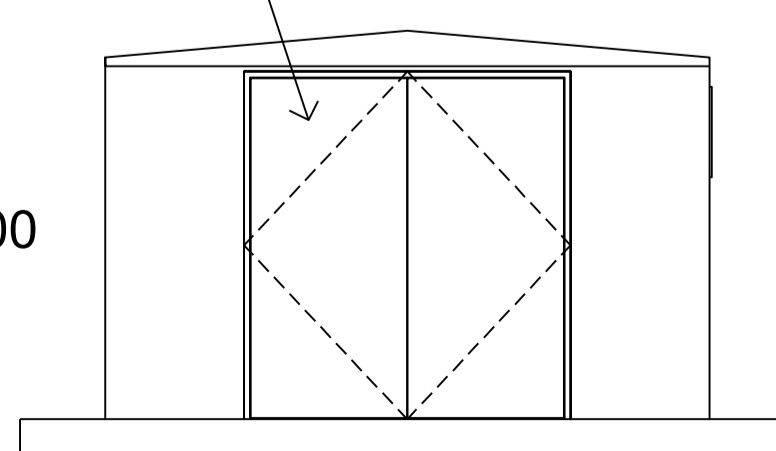

4 - SIDE ELEVATION

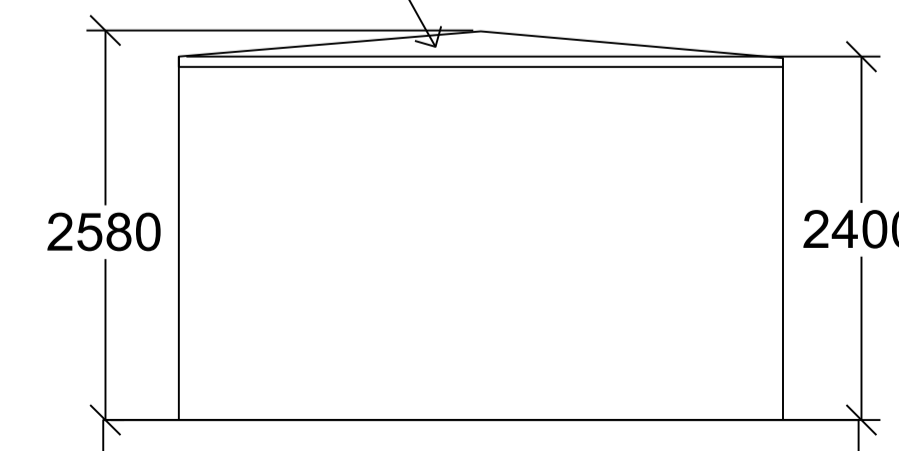

2 - SIDE ELEVATION

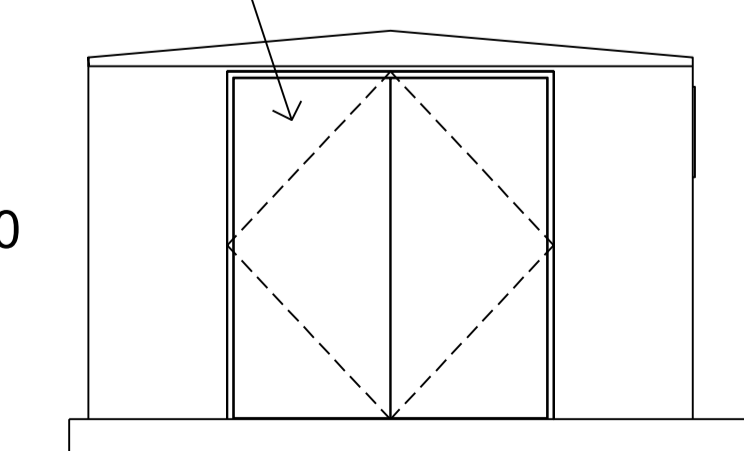

4 - SIDE ELEVATION



SCALE FOR PLANNING PURPOSES ONLY.

Architects are to be notified of any discrepancies.
Contractors must check all dimensions on site.
This drawing is subject to copyright laws and is for use on this project only.
This drawing is to be used solely for the information as titled only.
For other information refer to the latest revision of any cross referenced drawings.
To be read in conjunction with relevant design standards/protocols.

P02	10/08/21	UPDATED IN LINE WITH COMMENTS.	AH	MA
P01	02/08/21	FIRST ISSUE	DA	MA
REV	DATE	DESCRIPTION	DRN	CKD

AMENDMENTS
STATUS: **PLANNING**

CLIENT: **LYSANDER**

PROJECT NAME: **Southam Road, Banbury**

PROJECT ADDRESS: **Southam Road, Banbury OX16 3AE**

DRAWING TITLE: **SUBSTATION DETAILS**

JOB NO: **20-6507** DRG NO: **A018** REVISION: **P02**

DATE: **AUG 21** SCALE: **1:50** SHEET SIZE: **A1**



1 CARDALE PARK, BECKWITH HEAD ROAD,
HARROGATE HG3 1RZ
www.ssa-architects.co.uk
T: 01423 856999