

FOR CONSERVATION CHANNEL (SQUARE) TYPE CK2
USE CHANNEL (SQUARE) TYPE CS2

VARIES TO SUIT
VERGE/FOOTWAY
TREATMENT
SEE NOTE 6

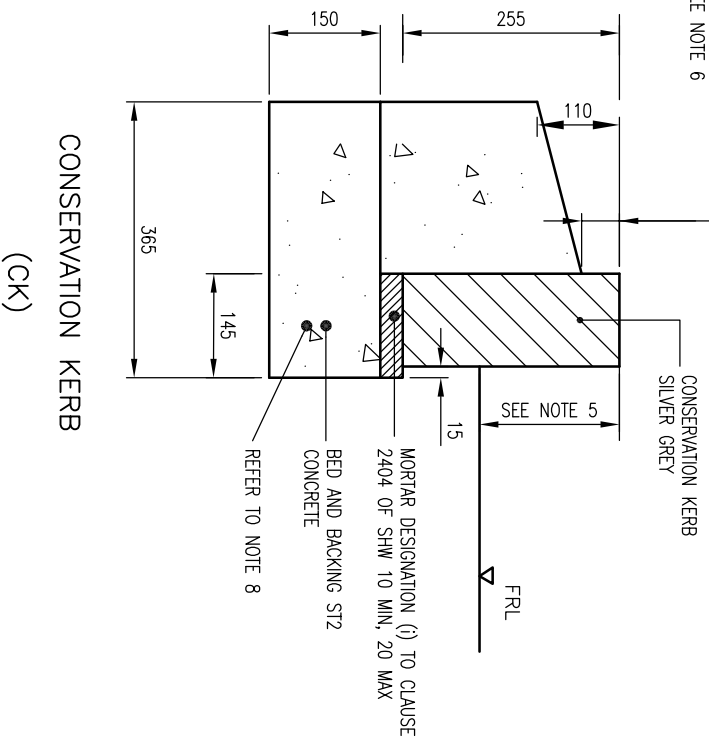

CONSERVATION KERB
(CK)

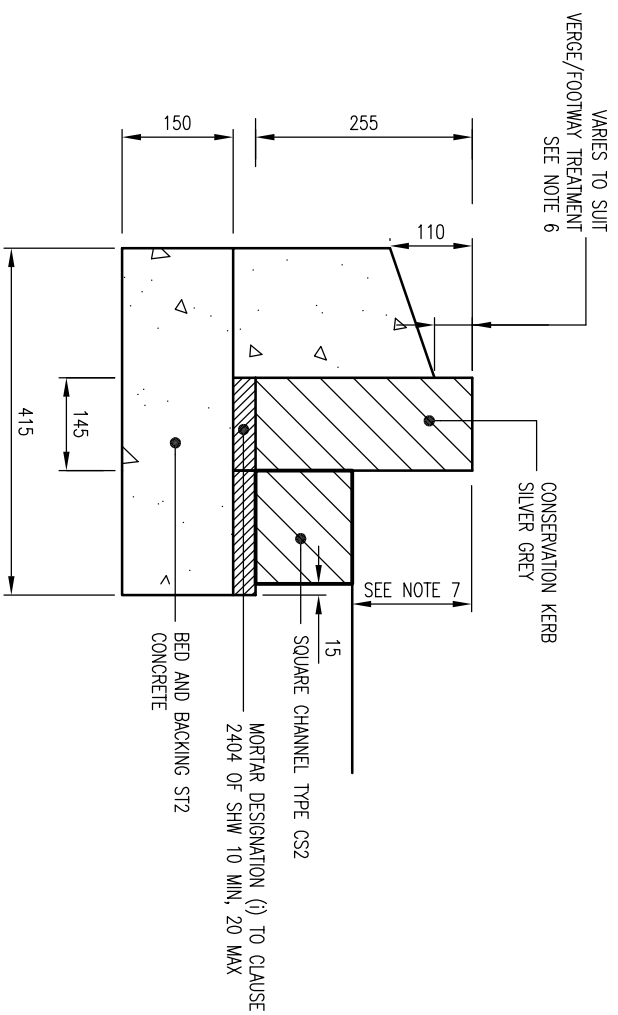

CONSERVATION KERB AND CHANNEL
(CKC)

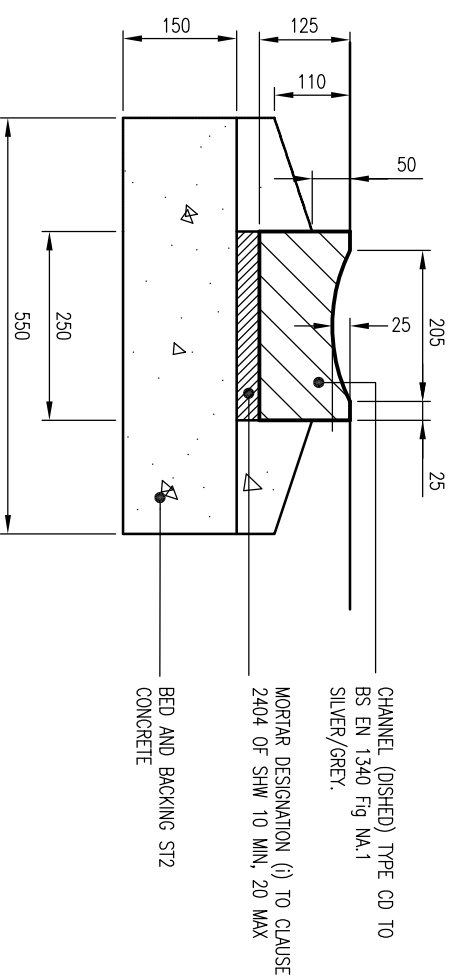

CHANNEL (DISHED) TYPE CD

- NOTES:
1. ALL DIMENSIONS ARE IN MILLIMETRES UNLESS OTHERWISE STATED.
 2. ALL CLAUSE NUMBERS REFER TO THE SPECIFICATION FOR HIGHWAY WORKS (SHW), LATEST EDITION.
 3. ALL PRECAST CONCRETE UNITS ARE TO CONFORM TO AND BE LAID IN ACCORDANCE WITH CL.1101 OF THE SPECIFICATION FOR HIGHWAY WORKS LATEST EDITION.

DO NOT SCALE

- NOTES:
4. KERB, BED AND BACKING SHALL BE ST2 GRADE CONCRETE TO CL.2602 OF THE SHW, LATEST EDITION.
 5. MECHANICAL HANDLING OF HEAVY ITEMS IS RECOMMENDED
 6. STANDARD PCC HB2 KERBS 69KG
 7. CONSERVATION KERB 83KG
 8. STANDARD PCC EDGING 45KG
 9. TO BE 30mm WHEN ADJACENT TO THE GRASSED VERGE, AND 50mm PLUS THE DEPTH OF THE PAVING STONE WHEN ADJACENT TO PAVING STONES.
 7. CONSERVATION KERB FACE (CK) TO BE 160mm HIGH UNLESS OTHERWISE INDICATED.
 8. FOR CONSERVATION KERB (CK) LOCATED AT ENDS OF CENTRAL RESERVATION (SPINE ROAD A CH0.000-420.000 INSTALL WITH 10 MM OPEN GAPS FOR DRAINAGE ALSO LEAVE OPENING IN BACKING AT JOINT.

REV	DATE	BY	DESCRIPTION	CHK	APP
D	18/02/10	JH	OCC COMMENTS INCORPORATED	JMM	JH
E	27/08/09	JAM	CHANGE OF CK2 SQ. CHANNEL TO CS2	JMM	JH
D	08/01/09	DP	TEXT AND NOTE AMENDMENTS	JMM	JH
C	12/12/08	JH	ISSUED FOR TECHNICAL APPROVAL	JMM	JH
B	30/05/08	JH	MINOR AMENDMENTS	LH	JM
A	11/03/08	PJ	FIRST ISSUE	LH	JM

FOR TECHNICAL APPROVAL



Mountbatten House, Basing View, Basingstoke, Hampshire RG21 4HU
Tel: +44 (0)1256 318800 Fax: +44 (0)1256 318700
<http://www.wspgroup.com>

CLIENT: COUNTRYSIDE PROPERTIES

ARCHITECT:

PROJECT: SOUTH WEST BICESTER
BICESTER, OXFORDSHIRE

TITLE: ON SITE WORKS
KERB TYPES SHEET 2 OF 3

SCALE @ A3: 1:10
CHECKED: LH
APPROVED: JM

CAD FILE: 1903-SD-211
DESIGNER/PAVING: PJ
DATE: January 2008

PROJECT No: 11011903
DRAWING No: 1903/SD/211
REV: F